

## Measurements for Condensation of Steam-Ethanol Mixtures in Microchannels

Lei Chai<sup>1</sup>, Nan Hua<sup>1</sup>, Rong Ji Xu<sup>1,3</sup>, Jiong Hui Liu<sup>1</sup>, Guang Xu Yu<sup>2</sup>, John W Rose<sup>1</sup>, Hua Sheng Wang<sup>1\*</sup>

<sup>1</sup>School of Engineering and Materials Science, Queen Mary University of London, London E1 4NS, UK

<sup>2</sup>DENSO Marston Ltd., Shipley, West Yorkshire BD17 7JR, UK

<sup>3</sup>Beijing University of Civil Engineering and Architecture, Beijing 100044, China

\* Corresponding author: h.s.wang@qmul.ac.uk

### Abstract

The paper reports heat-transfer measurements for condensation of pure steam and steam-ethanol mixtures in parallel horizontal microchannels in an aluminum test section cooled from above and below by water in counter-current flow. The local heat flux and channel surface temperature were determined from temperatures measured by 100 thermocouples accurately located in small holes above and below the microchannels and spaced at 10 locations in the flow direction. Tests were conducted for a range of vapor mass fluxes and cooling intensities. The streamwise distributions of channel heat flux, channel surface temperature and vapor quality were obtained by curve-fitting the test block temperatures. Heat-transfer coefficients were obtained for the cases where complete condensation did not occur in the channels by assuming linear pressure distribution between accurately measured pressures at inlet and exit and assuming saturation conditions in the two-phase flow region of the channels.

### Nomenclature

$G_v$  vapor mass flux  
 $m_c$  coolant mass flow rate  
 $h$  height of the channel  
 $n$  number of channels  
 $P$  pressure  
 $q_{ch}$  local heat flux from channel (Eq. (1))  
 $T$  temperature  
 $T_{ch}$  local channel wall temperature  
 $T_v$  local vapor temperature  
 $T_{c,in}$  coolant inlet temperature  
 $T_{v,in}$  vapor inlet temperature  
 $T_w$  channel wall temperature  
 $y$  distance measured through blocks normal to interface

$z$  streamwise distance (see Fig. 1a)  
 $w$  width of the channel  
 $W$  width of the cooling channel  
 $\alpha_{ch}$  local channel heat-transfer coefficient  
 $q_{ch}/(T_v - T_{ch})$   
 $\Delta P$  pressure drop, see Fig. 1a  
 $\chi$  local quality  
Subscript  
 $l$  lower block  
 $u$  upper block

### Introduction

Certain binary mixtures, where water is the main constituent, have been found to exhibit a mode of condensation resembling that of dropwise condensation which occurs only on hydrophobic surfaces. This has been termed Marangoni or pseudo-dropwise condensation and gives rise to very high heat-transfer coefficients. The mode of condensation and heat transfer enhancement depend strongly on composition. Intensive research has been conducted in recent years (Utaka et al. (2002, 2003, 2004), Murase et al. (2007), Ali et al. (2013)). For condensation of steam with very small concentrations of ethanol, experiments with vertical plane surfaces and horizontal tubes have given heat-transfer coefficients between 5 and 10 times those for condensation of pure steam, notwithstanding the vapour-phase diffusion resistance. In the context of electronics cooling, where extremely high heat fluxes are encountered, microchannel boiling of water, with its favorable heat transfer properties, is increasingly under consideration and requires compact and effective condensers. Furthermore, small concentrations of alcohols in the water have shown significant enhancement in boiling heat transfer (Fu et al. (2012), Fujita and Bai (1997), Peng et al. (1996), Sakashita et al. (2010)). The prospect of extremely

compact microchannel boiler-condenser units for electronic cooling prompted the present work. This paper describes an experimental study of condensation of steam and steam-ethanol mixtures in microchannel tubes.

### Apparatus

Figure 1 shows the test section which comprised two aluminum blocks, the lower block thickness 20.75 mm and the upper block thickness 19.25 mm. Ten parallel horizontal microchannels (1.5

mm deep  $\times$  1.0 mm wide) were machined in the mating surface of the lower block. The length of the microchannels was 500 mm. The upper and lower blocks each housed 50 thermocouples in small holes (0.6 mm diameter and 15.75 mm deep) spaced through the blocks at 10 locations in the flow direction. The blocks were cooled along the upper and lower surfaces by water in counter flow. Figure 2 shows a flow diagram of the apparatus.

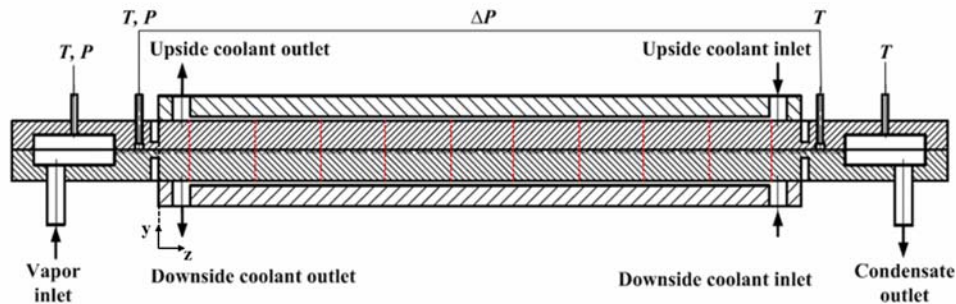

Fig. 1a Side view section of test blocks showing the streamwise positions of the block thermocouples.

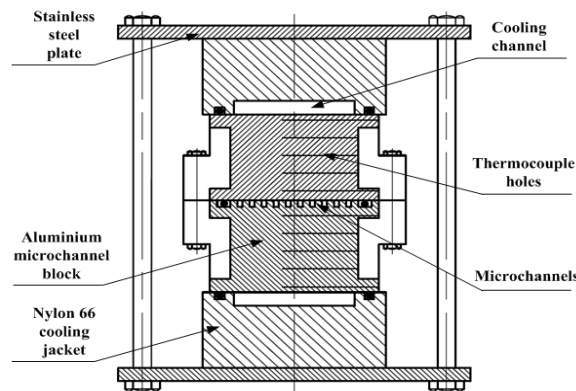

Fig. 1b Cross section through test blocks showing the lateral positions of the block thermocouples.

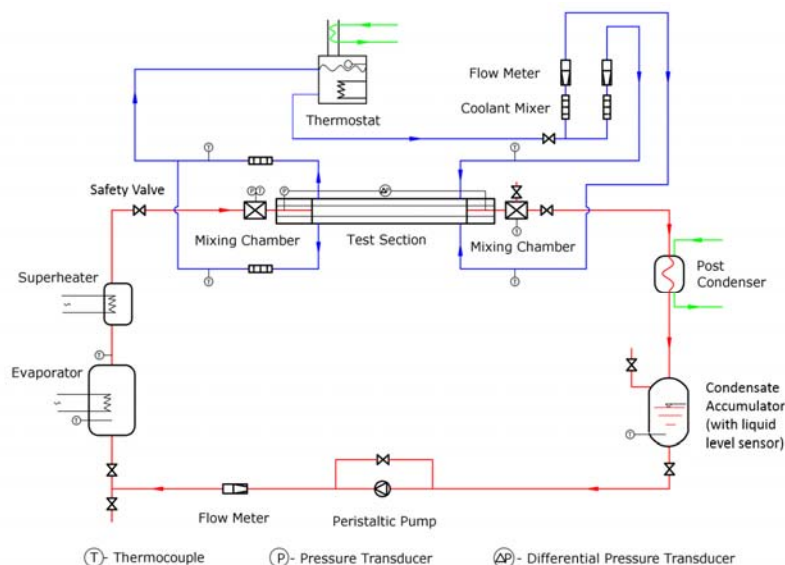

Fig. 2 Flow diagram of the apparatus.

## Procedure

Tests were done using pure steam and steam-ethanol mixtures (ethanol mass concentration in the boiler prior to starting the experiment from 0.01% to 1%) and mass flux (per channel) between  $50 \text{ kg}\cdot\text{m}^{-2}\cdot\text{s}^{-1}$  and  $100 \text{ kg}\cdot\text{m}^{-2}\cdot\text{s}^{-1}$ . Under steady state conditions temperatures and pressures were measured at the positions indicated in Fig. 1a and Fig. 1b, together with the vapor flow rate (values obtained from the condensate return flowmeter and by energy balance for the boiler agreed to within 2%). The coolant flow rates were set to the desired values (same for upper and lower channels). The pressure in the inlet plenum was between 1.0 bar and 1.4 bar for all tests.

## Results and discussion

Figure 3 shows an example of the measured temperatures in the test blocks. The interface temperature and heat flux at the interface and of the coolant sides of the upper and lower blocks were obtained by fitting quadratics (as shown in the figure) to the temperatures measured in the upper and lower blocks at each streamwise

location by extrapolation and from the appropriate temperature gradient respectively. The temperature in the blocks was taken to be laterally uniform. The total heat transfer to the coolant was obtained from the streamwise distribution of heat flux from the coolant-side surfaces of the blocks and generally agreed with values obtained from the coolant mass flow rate and temperature rise to around 3%.

Treating the interface between the blocks as a plane heat source, the total heat transfer rate from the interface to both upper and lower blocks over a short streamwise distance  $\Delta z$  is  $(q_u + q_l) W \Delta z$ , where  $q_u$  and  $q_l$  are the local heat fluxes from the interface into the upper and lower blocks respectively and  $W$  is the effective width of the blocks. Attributing this total heat transfer rate to  $n$  parallel channels the heat transfer rate from one channel over distance  $\Delta z$  is  $(q_u + q_l) W \Delta z/n$ . For channel height and width  $h$  and  $w$  respectively, the surface area of a channel over distance  $\Delta z$  is  $2(h + w) \Delta z$  and the channel heat flux is given by

$$q_{ch} = (q_u + q_l) W / \{2n(w + h)\} \quad (1)$$

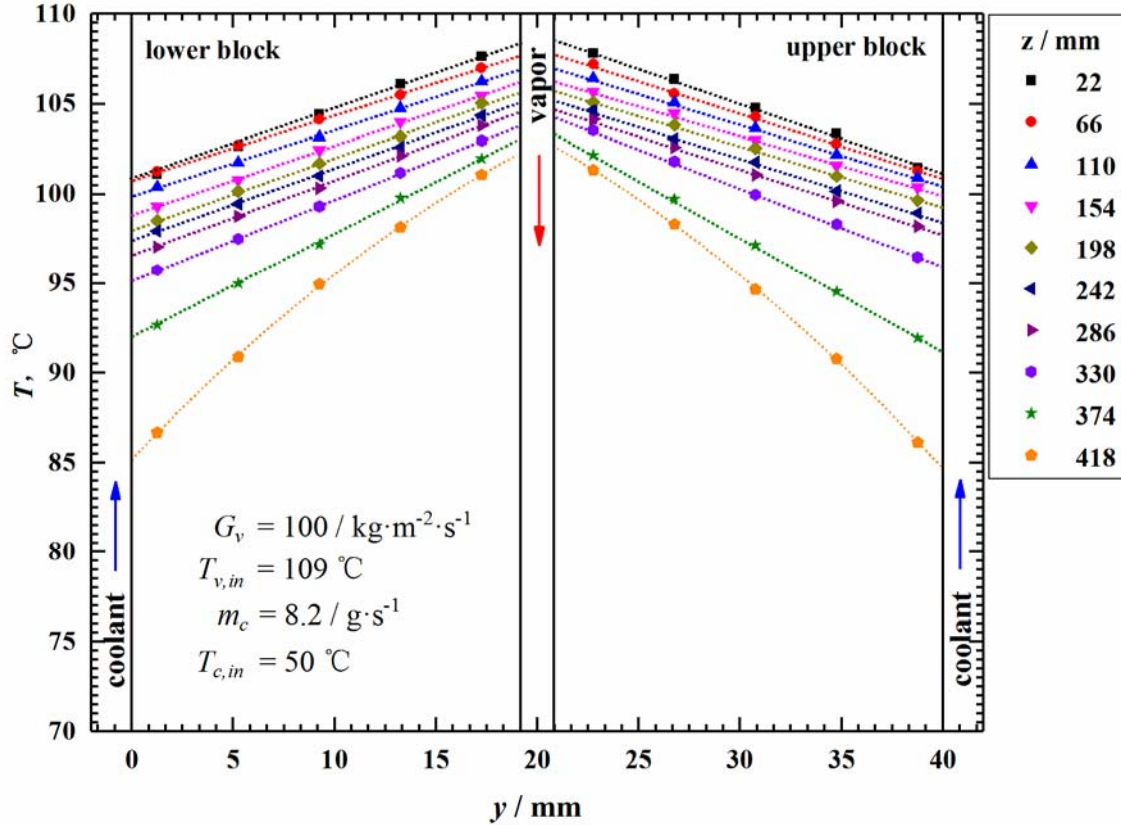

Fig. 3 Example of typical temperature distributions in the test blocks (pure steam).

In the present case

$W = 25 \text{ mm}$   
 $n = 10$   
 $w = 1.0 \text{ mm}$   
 $h = 1.5 \text{ mm}$

so that

$$q_{ch} = (q_u + q_l)/2 \quad (2)$$

and the channel surface temperature  $T_{ch}$  was taken as the mean of the values of the interface temperatures for the upper and lower blocks.

Figure 4 shows an example of streamwise distribution of channel heat flux for a pure steam case with incomplete condensation (quality greater than zero at exit). Except near the vapor inlet the shape of the heat flux curve is largely dominated by the coolant side with the counter flow arrangement.

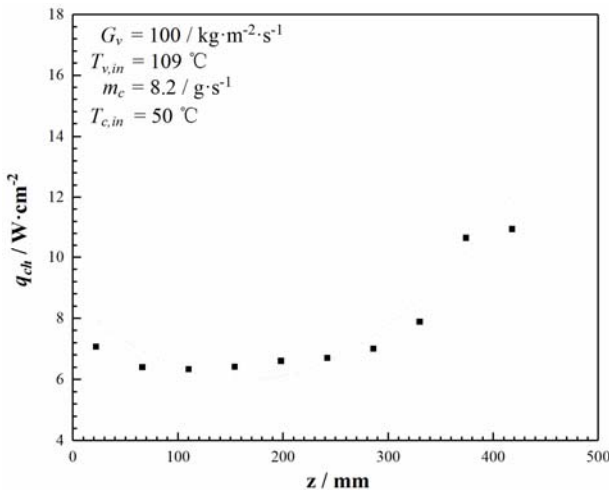

Fig. 4 Typical example of variation of channel heat flux along the channel (pure steam).

Figure 5 shows a case where complete condensation occurs within the channels. The rising heat flux near the position of “flooding” of the channels is due to the fact that the cooling water (in counter flow) remains relatively cold for the remainder of the channel where the heat flux is low as can be seen from the temperature distributions shown in Fig. 6.

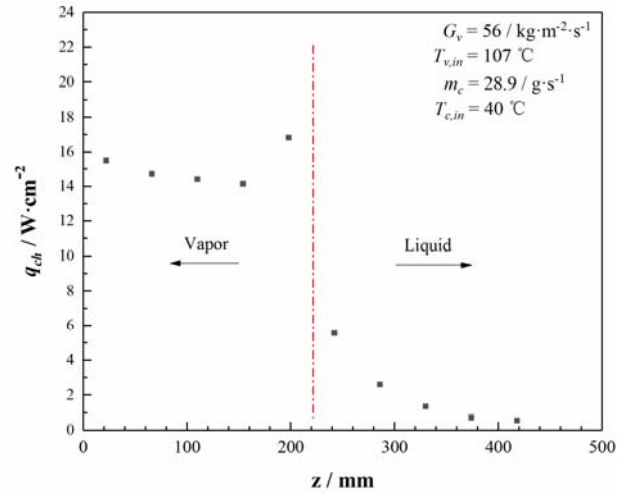

Fig. 5 Heat flux distribution for case where complete condensation occurs within the channels (pure steam).

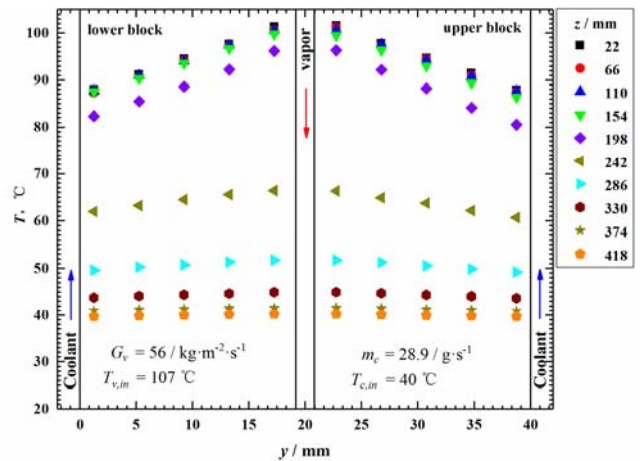

Fig. 6 Temperature distributions in the test blocks for case where complete condensation occurs within the channels (pure steam).

For the cases of incomplete condensation, heat-transfer coefficients can be obtained by estimating the local vapor temperature from the measured values of pressure near the inlet and exit where the vapor was saturated. The local temperature was taken as the saturation value using linear pressure distribution. Typical examples of dependence of local heat-transfer coefficient on distance along the channels and local quality for pure steam are shown in Figs. 7 and 8. Figure 9 shows the variation of channel wall temperature and heat-transfer coefficient respectively for steam and steam-ethanol mixtures. Figure 10 shows an example of the dependence of heat-transfer coefficient on distance along the channels for pure steam and steam-ethanol mixtures. In calculating the heat-transfer coefficient for the mixtures it was deemed adequate, for the small ethanol

concentrations used, to take the vapor temperature as the saturation temperature of steam. It is seen in all cases that the heat-transfer coefficient is very high near the channel inlet but falls steeply to an almost constant value for the remainder of the channel. The heat-transfer coefficients are around ten times those typically found for condensation of refrigerants in microchannels and not strongly dependent of vapor mass flux for the ranges used. Unlike condensation on external surfaces no discernable enhancement is obtained through addition of small quantities of ethanol in the steam.

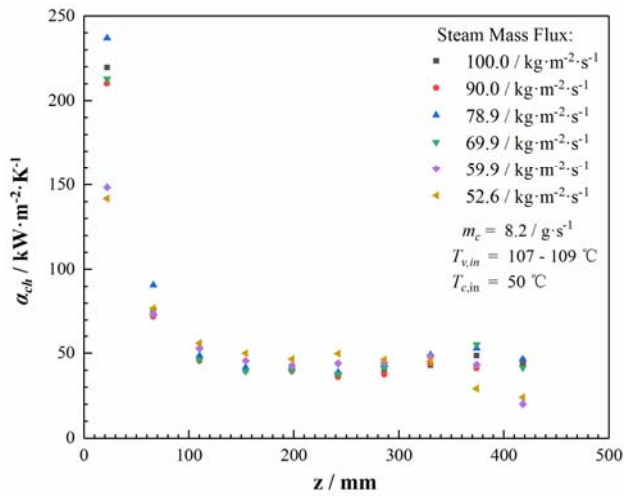

Fig. 7 Distribution of heat-transfer coefficient along the channels for case with incomplete condensation (pure steam).

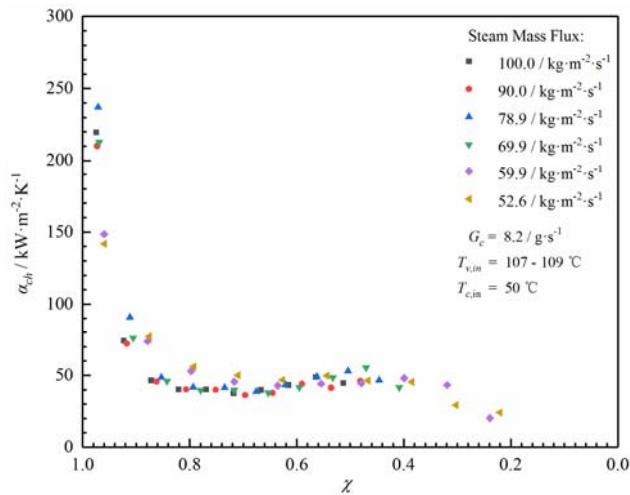

Fig. 8 Variation of heat-transfer coefficient with quality for case with incomplete condensation in the channels (pure steam).

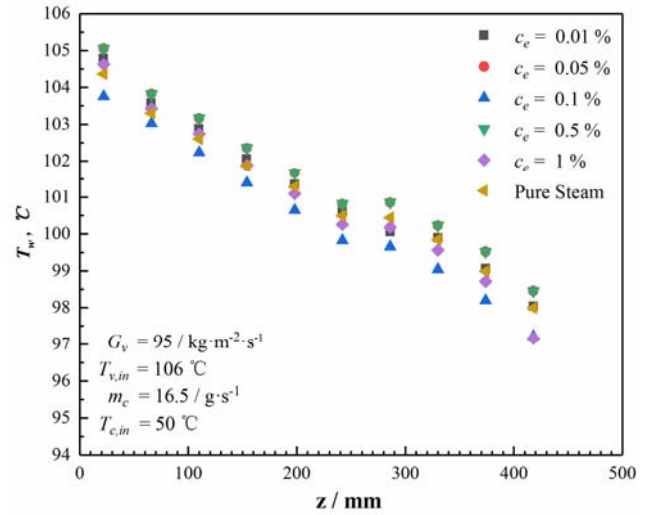

Fig. 9 Channel wall temperature variation along the channels for steam and steam-ethanol mixtures.

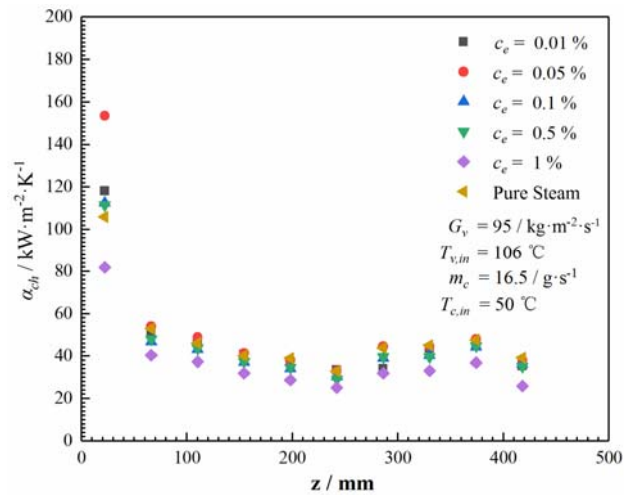

Fig. 10 Channel heat-transfer coefficient variation along the channels for steam and steam-ethanol mixtures.

### Concluding remarks

For pure steam, heat-transfer coefficients for condensation in microchannels are around 5 to 10 times those typically reported for refrigerants. Unlike the cases of condensation on plates and tubes the heat-transfer is not enhanced by addition of small amounts of ethanol. This is thought to be attributable to the mode of condensation prevailing in the confined space of microchannels. In experiments where flow visualization for condensation of FC72 in microchannels was possible (Kim and Mudawar (2012)) annular flow was noted as the predominant mode of condensation and the experimental results agreed closely with annular laminar flow theory (Wang



and Rose (2005, 2011)). Significantly higher heat-transfer coefficients than found in the present investigation were anticipated for steam on the basis of annular laminar flow theory. Future investigation of the mode of condensation is planned using a transparent plate in place of the upper test block.

### Accuracy of Measurements

All temperatures were measured to within 0.05 K having regard to calibration and isothermal immersion of the leads. The locations of thermocouples in the blocks were known to within 0.3 mm. These can be judged from the block temperature distributions in Fig. 3. Local heat fluxes at the interface between the blocks was estimated from the least squares fits to be better than 2%. Uncertainty due to possible non-uniform transverse temperature variation is difficult to quantify but the close agreement between the directly measured heat-transfer rate to the coolant and that found from the local coolant-side heat flux from the blocks indicates that this error was not large. Possible error in the reported channel heat-transfer coefficients is judged to be much less than would invalidate the main conclusions above. This is also true in relation to taking the vapor temperature to be that of pure steam for the very small concentrations of ethanol used.

### Acknowledgements

Financial supports from the Engineering and Physics Science Research Council (EPSRC) of the UK (EP/L001233/1, EP/N001236/1), DENSO Marston, UK and the Science and Technology Program of Guangzhou (201704030108), China are acknowledged.

### References

Ali, H., Wang, H. S., Briggs, A. and Rose, J. W. (2013). Effects of vapour velocity and pressure on Marangoni condensation of steam-ethanol mixtures on a horizontal tube. *Trans. ASME J. Heat Transfer*, **135**, 031502.

Fu B., R, Tsou M S and Pan C. (2012). Boiling heat transfer and critical heat flux of ethanol-water mixtures flowing through a diverging microchannel with artificial cavities. *Int. Journal Heat and Mass Transfer*, **55**, 1807-1814.

Fujita Y. and Bai, Q. (1997). Critical heat flux of binary mixtures in pool boiling and its correlation

in terms of Marangoni number. *Int. J. Refrigeration*, **20**, 616-622.

Kim, S-M., and Mudawar, I. (2012). Flow condensation in parallel microchannels – Part 2: Heat transfer results and correlation technique. *Int. J. Heat Mass Transfer*, **55**, 984-994.

Murase, T., Wang, H. S. and Rose, J. W. (2007). Marangoni condensation of steam-ethanol mixtures on a horizontal tube. *Int. J. Heat Mass Transfer*, **50**, 3774-3779.

Peng X. F., Peterson G. P. and Wang B. X. (1996). Flow boiling of binary mixtures in microchanneled Plates. *Int. Journal Heat and Mass Transfer*, **39**, pp 1257-1264.

Sakashita, H., Ono, A., Nakabayashi, Y. (2010). Measurements of critical heat flux and liquid-vapor structure near the heating surface in pool boiling of 2-propanol/water mixtures. *Int. Journal Heat and Mass Transfer*, **53**, 1554-1562.

Utaka, Y. and Wang, S. (2002). Promotion of steam condensation heat transfer using solutal Marangoni condensation. *Trans. JSME* (in Japanese), **68**, 148-156.

Utaka, Y. and Kobayashi, H. (2003). Effect of velocity on condensation heat transfer for steam-ethanol binary vapor mixture. Proc. 6<sup>th</sup> ASME-JSME Thermal Engng. Joint Conf., CD paper TED-AJ03-604.

Utaka, Y. and Wang, S. (2004). Characteristic curves and the promotion effect of ethane diol addition on steam condensation heat transfer. *Int. J. Heat Mass Transfer*, **47**, 4507-4516.

Wang, H. S. and Rose, J. W. (2005). A theory of film condensation in horizontal noncircular section microchannels. *Trans. ASME J. Heat Transfer*, **127**, 1096-1105.

Wang, H. S. and Rose, J. W. (2011). Theory of heat transfer during condensation in microchannels. *Int. J. Heat Mass Transfer*, **54**, 2525.