

THE DEMONSTRATIVE NATURE OF
THE HINDI/MARWARI CORRELATIVE

Anne Beshears

Submitted in partial fulfillment of the requirements
for the degree of
Doctor of Philosophy in Linguistics

JANUARY 2017

SCHOOL OF LANGUAGES LINGUISTICS AND FILM
QUEEN MARY UNIVERSITY OF LONDON

I, Anne Beshears, confirm that the research included within this thesis is my own work or that where it has been carried out in collaboration with, or supported by others, that this is duly acknowledged below and my contribution indicated. Previously published material is also acknowledged below.

I attest that I have exercised reasonable care to ensure that the work is original, and does not to the best of my knowledge break any UK law, infringe any third party's copyright or other Intellectual Property Right, or contain any confidential material.

I accept that the College has the right to use plagiarism detection software to check the electronic version of the thesis.

I confirm that this thesis has not been previously submitted for the award of a degree by this or any other university.

The copyright of this thesis rests with the author and no quotation from it or information derived from it may be published without the prior written consent of the author.

Signature:

Date:

Details of collaboration and publications:

Beshears, Anne. (2015) *The Hindi correlative as an overtly pronounced index*. Mythili Menon and Saurov Syed, eds. Proceedings of FASAL 6. University of Massachusetts.

Beshears, Anne. (2016) *Licensing the correlative via the semantics of the demonstrative*. Bellamy, Kate, Elena Karvovskaya and George Saad, eds. ConSOLE XXIV: Proceedings of the 24th Conference of the Student Organization of Linguistics in Europe (6-8 January 2016, York). Leiden: Leiden University Centre for Linguistics.

Abstract

One of the main features of the correlative construction is the necessity of an appropriate correlate (either a demonstrative or a pronoun) in the main clause. While the syntactic features of the correlative construction are well established, the relationship between the correlative clause and its correlate remains unclear.

In this dissertation, I propose that the correlative clause is the overt pronunciation of the index of the demonstrative. The correlative, therefore, does not adjoin to IP (Dayal 1996) or the demonstrative (Bhatt 2003) but enters the syntax as the indexical argument of the demonstrative phrase (Nunberg 1993; Elbourne 2008). I then turn to the adverbial correlative clause, which involves an adverbial relative phrase, and show that it is also the overt pronunciation of the index and, further, that it is interpreted as a definite description and contributes an individual of type e .

Having established the relationship between the correlative clause and its correlate, I develop a new analysis of the semantic contribution of both the single headed correlative, involving one relative phrase, and the multi-headed correlative which involves multiple relative phrases. I propose that the correlative gets its interpretation through a Q particle, Q_{COR} , which raises from the relative phrase to Spec-CP. It is Q_{COR} which allows both adverbial and nominal correlatives to have a definite interpretation. I present new data from Hindi and Marwari which shows that the multi-headed correlative is base-generated inside of the main clause, at the highest demonstrative or below, and denotes an ordered pair. Each member of that set is then an argument of one of the demonstratives in the main clause.

Finally, if the proposed analysis is correct, then it should follow that other types of phrases can occur in the same position. Not only is this possible in Hindi and Marwari, but sign languages and Mandarin Chinese allow overt indices as well.

*marwaṛ mē, hār koṛ ã paṇi bādāḷe ne,
tin koṛ ã vaṇi*

*In Marwar, the taste of the water changes
every 2 km, the language every six.*

To the people of Marwar, with thanks.

Acknowledgments

When I chose to work on correlatives, it was because I didn't want to get pigeon-holed into a narrow topic which I would be stuck doing for the rest of my linguistics career. Naively, I thought that a dissertation would be comprehensive and say everything that there was to say about the topic. Instead, my entire dissertation covers what I thought would be just the first chapter, and there are still many lingering questions which won't be answered here. For this reason, I must thank all of the supervisors and mentors who helped guide me through the process of tackling a research project, learning what to focus on, and learning where to prune – sometimes quite aggressively.

Often people have said to me that doing a PhD is very lonely work. This has never been my experience. Both at JNU and at QMUL, I have been blessed with great departments who were supportive, friendly, and a pleasure to be a part of.

Thanks to Ayesha Kidwai for introducing me to syntax and bearing with my initial attempts to apply what we were learning to Hindi, even when I didn't actually speak Hindi that well. It was a real pleasure being part of your classes. Benu Sharon, Jyoti Iyer, Diti Bhadra, and all of my other JNU cohorts: It was a joy and privilege to study alongside you. I'm sure I learned as much from all of you as I did from our classes! Thank you, Utpal Lahiri, for teaching us semantics and our first introduction to λ -abstraction. At the time, semantics felt so far over my head, but looking back I realize how much I learned throughout our courses. Veneeta Dayal: You were actually our first introduction to semantics and, as you could tell, we had no idea what we were doing! Thank you for your patience. Your class was my first introduction to semantic fieldwork and to the possibility of studying a language you didn't actually speak fluently.

At Queen Mary, first of all, thanks to my supervisors Luisa Marti, Daniel Harbour, and Paul Elbourne. Luisa, working with you was a real delight!

You jumped in mid-way into my project, without knowing anything about correlatives or Hindi, and helped me through one of the hardest aspects of this whole process: writing everything down on paper. Daniel, thank you for your encouragement both in writing and in doing fieldwork. I enjoyed being able to bounce ideas around and exploring new approaches. Paul, thanks for taking me on as a new PhD student and for giving me the freedom to explore a bit before settling on a final topic. It was you who taught me the importance of paying attention to detail, a lesson which has held me in good stead throughout my PhD. Thanks also to David Adger, Hagit Borer, Devyani Sharma, Coppe van Urk and everyone else who came to presentations, asked questions, made comments, and suggested different ways to think about a problem.

The highlight of my time at Queen Mary, though, is my classmates. As much as I look forward to having a real office someday, it's been great fun working in the LingLab with all of you. Danniella: Thanks for sitting next to me! Reem, Annette, and Panpan: It's been great fun going through this whole process together. Dave: Thanks for leading many trips to the Morgan Arms and The Coburn. Melisa: Without you, I wouldn't have known that bare singulars even existed. (I'm still not sure whether that's a good thing or not.) Anyway, you all know who you are. I will miss working with all of you day to day, but I hope that we will cross paths here and there soon!

Thanks also to my family and friends who have supported me and encouraged me throughout this process. Thanks, Mom and Dad, for demonstrating that learning is important and encouraging me that I can do anything I can set my mind to. Thanks, Kim, Jess, and Monica for your encouragement and believing in me throughout this process. And, thanks to the rest of my family who still don't entirely understand why I would want to go to this much trouble just to study linguistics but who would drop everything to come to India and bring me back home if I was ever in trouble. Thank you to all of my dear friends in Missouri and around the world who are always up for a coffee and a good chat whenever I come home. Most of all, thanks for your patience and forgiveness when I disappear for a year in order to finish 'writing-up'.

Thank you to my church family at Christian Fellowship. Mike: Thanks for being available to talk so often and for seeing me through some pretty tough times. You and the team coming to visit me in India has meant so much. Phil: Thanks for being excited about correlatives and language! Most people's eyes glaze over pretty quickly when I explain what correlatives are, but you just

get more excited. Bob and Doris: Having a second home with you has been such a blessing. There were so many times when I needed, not only a place to land but a place to decompress and debrief. Thanks for being that. And to everyone else: Thanks for your continued support and being excited for me, even when you may not be excited about correlatives.

I want to include a special thanks to all my friends in India. You made my experience in India worthwhile, and I wouldn't have been able to finish this without your friendship. First of all, many thanks to Amber and Namita, Imran and Uzma, and Rohit and Geetika. We started out talking shop over late night chai and parathas at the dhaba. These days, our conversations are less often and scattered all over the world, but your friendships mean just as much now as they ever have. Divya: I'll never forget the day your Dad brought me over and didn't tell me it was your birthday! I'm sorry we don't get to see each other as often as we used to, but I'm so excited to see what God is doing in your life and I'm so thankful for our chats however often we are able to have them. Ken and Joyce: You first introduced me to India, having only just arrived yourselves. I have been so blessed by knowing you over the years. And, to all of my other SAG friends: It's been a pleasure working with you. Thank you for letting me be a part of your family; your passion and drive for the sake of Christ is inspiring.

Most of all, thank you to all of the Hindi and Marwari speakers who shared their language and culture with me. Thank you for your patience when I asked silly questions which you had already explained, when I didn't understand what you were trying to tell me, and for being willing to sit and talk about Marwari or Hindi when I'm sure you had many, many other things you could be doing. Thank you to Aashiq Ilahi, Vijay Dewra, Ritu Sisodiya, Nisha Chawriya, Narayan Lal Suthar, Manish Khatri, Arab Khan, Ravi Prakash, Ishwar Lal Sagra, Laxman Ram, Gangaram Bhomaram, Ramnarayan Chokharam, and Anuj. Without your help, this dissertation could never have happened.

Finally, thanks to God who brought me to London and who has guided me at every turn. You have been faithful to me throughout.

Contents

1	Introduction to the correlative construction	14
1.1	MIA Relativizing Structures	14
1.1.1	Postnominal Relative Clauses	15
1.1.2	Correlatives	17
1.1.3	Prenominal Relative Clauses	19
1.2	Introduction to the Analysis	20
1.3	Variation in Hindi and Marwari	22
1.3.1	Defining what is meant by Hindi	24
1.3.2	Three varieties of Marwari	26
1.4	Other topics not covered	29
1.4.1	The postnominal relative pronoun	29
1.4.2	Free choice correlatives	31
1.4.3	Relative constructions at the right periphery	32
1.4.4	If-then variations on the correlative construction	34
1.4.5	(Clausal) Comparatives	35
1.4.6	Scrambling	36
2	The nominal correlative	39
2.1	Looking ahead	39
2.2	The Correlative Cross-Linguistically	40
2.2.1	Terminology	42
2.2.2	Defining Features of the Correlative Construction	44
2.3	Previous analyses of the correlative	59
2.3.1	The correlative as a quantifier adjoined to IP	61
2.3.2	The correlative is base-generated at the DemP	64
2.3.3	Remaining Questions	74
2.4	Conclusion	74

3	The demonstrative nature of the nominal correlative	77
3.1	The correlative and the demonstrative	77
3.2	Internal Structure of the Demonstrative	79
3.3	The correlative as an overt index of the demonstrative	87
3.3.1	The correlative-demonstrative constituent	88
3.3.2	Dual headedness in the correlative construction	91
3.3.3	Pronominal correlates in Bangla	94
3.3.4	A note on bare demonstratives	98
3.3.5	Correlative fronting: Subject and Adjunct Islands	99
3.4	Implications and Predictions	102
3.4.1	The proximity of the index	102
3.4.2	First and second person correlates	104
3.5	Deferred Reference in Correlatives	107
3.6	Conclusion	114
4	The adverbial correlative	117
4.1	The purpose and direction of this chapter	117
4.2	The adverbial correlative construction	120
4.3	Adverbial correlatives are true correlatives	125
4.3.1	The demonstrative requirement	126
4.3.2	The correlative-correlate constituent	129
4.3.3	The adverbial wh_{RC} may also remain in-situ	133
4.3.4	Headedness and case marking	134
4.3.5	Adverbial multi-headed correlative construction	138
4.3.6	Summary: Features of the Adverbial Correlative	141
4.4	Adverbial correlatives are not adverbs	141
4.4.1	Adverbial correlatives cannot act as adverbs	142
4.4.2	Adverbial correlatives do act as nominals	147
4.4.3	Mismatched correlative constructions	150
4.4.4	Adverbial correlatives are nominal phrases	153
4.5	Conclusion	154
5	The demonstrative nature of the adverbial correlative	156
5.1	The adverbial CorrelCP-correlate constituent	156
5.2	Internal structure of locative PPs	157
5.2.1	The eigenspace of the reference object	159
5.2.2	The SORT phrase	161

5.2.3	The syntax of locative PPs	162
5.2.4	The adverbial adpositional phrase	165
5.3	The adverbial demonstrative	166
5.3.1	Deferred reference and adverbials	166
5.3.2	Syntax of the locative demonstrative	169
5.3.3	Other adverbial demonstratives	173
5.4	The adverbial correlative as an index	175
5.4.1	The adverbial correlative construction	176
5.4.2	Deferred Reference in Adverbial CorrelCPs	181
5.5	Conclusion	183
6	The structure and meaning of single headed correlatives	184
6.1	Introduction to the Analysis	184
6.2	The correlative as a definite description	185
6.2.1	A formal definition of definiteness	186
6.2.2	Maximality/uniqueness in correlatives	189
6.2.3	Correlatives carry a uniqueness presupposition	192
6.2.4	Correlatives are definite descriptions	194
6.3	The relative pronoun as a <i>wh</i> -element	195
6.3.1	Morphological similarity between <i>wh</i> -elements	196
6.3.2	MIA languages are <i>wh</i> _{RC} in-situ	198
6.3.3	Interpreting the <i>wh</i> _{RC} in-situ: Introducing Q _{COR}	201
6.3.4	The advantages of a Q _{COR} approach	206
6.3.5	Conclusion	212
6.4	Deriving the nominal correlative	214
6.4.1	The internal composition of the <i>wh</i> _{RC} -phrase	214
6.4.2	Derivation of the nominal correlative	217
6.4.3	Evidence that the correlative is not a DP	221
6.5	Deriving the adverbial correlative	223
6.5.1	The adverbial <i>wh</i> _{RC} -phrase	223
6.5.2	Derivation of the adverbial correlative	226
6.6	Conclusion	231
7	The multi-headed correlative and its interpretation	234
7.1	The multi-headed correlative construction	234
7.2	Syntactic features of the MHC	236
7.2.1	The MHC and demonstrative requirement	237

7.2.2	Interpretation of MHC constructions	239
7.2.3	Introduction to an analysis of MHCs	242
7.3	The MHC merges clause internally	242
7.3.1	The MHC can be pronounced inside the main clause	243
7.3.2	MHCs and Island Effects	245
7.3.3	The Coordinate Structure Constraint and MHCs	250
7.3.4	Binding effects and MHCs	260
7.3.5	Conclusions	263
7.4	A proposed analysis of the MHC Clause	263
7.4.1	Previous analyses of the MHC	264
7.4.2	Interpretation of the MHC	269
7.5	The MHC and its correlates	275
7.5.1	The MHC does not bind the lower demonstrative	277
7.5.2	The MHC as an overt spell out of both indices	279
7.5.3	The order of demonstratives in Marwari	289
7.6	Conclusion	292
8	Methods: Interpreting unfamiliar constructions	295
8.1	The purpose of this chapter	295
8.2	An overview of Hindi/Marwari fieldwork	296
8.3	Eliciting accurate grammaticality judgments	299
8.3.1	Eliciting through translation	300
8.3.2	Eliciting grammaticality judgments	302
8.3.3	Other methods of testing grammaticality: Number scale	306
8.3.4	Clear delineation of tasks	307
8.3.5	When all else fails	309
8.4	Testing binding effects and Condition C	310
8.4.1	How not to test for binding effects	313
8.4.2	Testing binding effects: ‘Plausible Dissent’	316
8.5	Testing for presuppositions	322
8.6	Conclusion	328
9	Implications and conclusions	330
9.1	Introduction	330
9.2	Other MIA correlative-type constructions	331
9.3	Overtly pronounced indices in languages without correlatives	336
9.3.1	Pronouns in sign language	337

9.3.2	Mandarin Chinese	340
9.3.3	Summary	343
9.4	Why can't participials be indices?	344
9.5	Summary and theoretical implications	349
A	Some brief comments on Marwari grammar	356
B	Testing for binding effects: stories with Plausible Dissent	379
C	Testing for presuppositions: Tiger in the Bush story	396

Abbreviations and Glossing

1	First person	MC	Main Clause
2	Second person	M	Masculine
3	Third person	MHC	Multi-headed correlative
ACC	Accusative	NEG	Negation
CL	Classifier	OBL	Oblique
COMP	Complementier	PFV	Perfective
COR	Correlative	PL	Plural
DAT	Dative	PRO	Pronoun
DEM	Demonstrative	PROG	Progressive
DET	Determiner	PROH	Prohibitive
DIST	Distal	PROX	Proximal
ERG	Ergative	PRS	Present
EXCL	Exclusive	PST	Past
FAM	Familiar	PART	Participial
F	Feminine	Q	Question
FUT	Future	RC	Relative Clause
HON	Honorific	SG	Singular
INCL	Inclusive	SHC	Single headed correlative
INF	Infinitival	SRC	Source
IMP	Imperative	SUBJ	Subjunctive
IMPFV	Imperfective		
LGT	Light		
LOC	Locative		

Chapter 1

Introduction to the correlative construction

1.1 MIA Relativizing Structures

Relative clauses are generally classified as one of four different types, defined primarily based on their surface word order. Three of those relative clause types occur in Hindi, Marwari, and other Modern Indo-Aryan (MIA) languages.¹

(1) Three Types of Relative Clauses:

1. **Postnominal Relative Clauses** follow the N or NP.
2. **Correlatives** are relativizing clauses marked by a relative pronoun which relate to a demonstrative or pronoun in the main clause and which often occur at the periphery of the main clause.
3. **Prenominal Relative Clauses** precede the modified noun (N) or noun phrase (NP).

All of these types are common across languages and language families (de Vries 2001), and it is often the case that a single language will have access to more than one type of relativization strategy. The strategies available in a

1. The fourth type of relative clause according to de Vries (2001) is the circumnominal. Circumnominal relatives are not present in Hindi or Marwari so will not be discussed in this dissertation.

language may be constrained by the nature of the relativization site and with respect to the semantic type of relative clause (Bianchi 2002a).

All types of relative clauses are embedded within the main clause, but they may differ in whether they are embedded within the DP itself (such as postnominal relatives) or just below the highest level of the matrix clause (such as a fronted correlative).

Each of these types of relative clause has a headed and a free relative variant (de Vries 2001, from Lehmann 1984). A free relative is a relative clause which enters the syntax directly and which is not associated with a head noun in the main clause. Because free relatives parallel these four types of relative clauses, de Vries and others do not consider them to be their own type but to be a variation of the other types of relative clause.

1.1.1 Postnominal Relative Clauses

Postnominal relatives are the most common type of relative clause and the dominant relativization strategy cross-linguistically (de Vries 2001). These relative clauses follow and are usually adjacent to the modified noun (NP_{MC}), sometimes called the head noun, though they may be extraposed to the right periphery of the main clause. The primary relativization strategy of English is the postnominal relative, but Hindi and Marwari have this construction as well. (2) is an example of an English postnominal relative clause (RC) construction.

(2) Kimberly bought [_{DP} the [_{NP} treats [_{RC} which her cat likes most]]].

Relative pronouns in postnominal relatives are said to always be clause initial, although they may occasionally be embedded in a PP or NP (de Vries 2005, citing Downing 1973; Kachru 2006). de Vries (2005) concludes that relative pronouns or wh_{RC} -phrases are moved to the CP domain of the embedded clause in the same way as interrogative wh -phrases. There are exceptions to this, such as Bambara, which allows in situ head noun and relative pronoun constituents.

The relative pronoun can remain in its base position in postnominal relative clauses. Hindi and Marwari are both wh in situ languages, but neither language allows in situ wh_{RC} -phrases in postnominal relatives. As seen in example (3), the relative pronoun must precede the rest of the postnominal relative clause.²

2. Throughout, I will give a free translation which reflects the structure of the language

- (3) a. *larkī* [RC [RelP *ḍāḷo*] *ram ko pasənd he*]
 girl.F.SG which ram DAT liking be.PRS.3.SG
aegi
 come.FUT.F.SG
 '[A] girl who Ram likes will come.' [HINDI]
- b. *t̪ʰori* [RC [RelP *ḍāḷiko*] *ram ne pasənd he*]
 girl.F.SG which ram DAT liking be.PRS.3.SG
ave|a
 come.FUT.F.SG
 '[A] girl who Ram likes will come.' [MARWARI]

If the relative pronoun remains in situ inside of the relative clause CP, then the sentence is ungrammatical. This is illustrated in (4a) and (4b) for Hindi and Marwari.

- (4) a. * *larkī* [*ram ko* [RelP *ḍāḷo*] *pasənd he*]
 girl.F.SG Ram DAT which liking be.PRS.3.SG
aegi
 come.FUT.F.SG
 Intended: '[A] girl who Ram likes will come.' [HINDI]
- b. * *t̪ʰori* [*ram ne* [RelP *ḍāḷiko*] *pasənd he*]
 girl.F.SG Ram DAT who liking be.PRS.3.SG
ave|a
 come.FUT.F.SG
 Intended: '[A] girl who Ram likes will come.' [MARWARI]

Bhatt (2003) suggests that postnominal relative clauses have the structure in (5), where the relative phrase is part of the NP.

- (5) [DP that [NP book [CP which [is on sale]]]]

Though analyses differ, most assume that the head of the postnominal NP (NP_{RC}, for example *book* in 5 above) and the relative clause are part of the same constituent, where the relative clause acts as a restrictive modifier. In the

being translated as closely as possible. I am not assuming that all free translations will be entirely acceptable in English.

postnominal relative construction, the head noun *kitab* ‘book’ is not a sister to the relative pronoun $\widehat{d\bar{3}o}$ ‘which’ but is a sister to the relative clause $\widehat{d\bar{3}o\ sel\ p\bar{a}r\ h\bar{e}}$ ‘which is on sale’.

In (6), the relative clause has been moved away from the head noun, extraposed to the right periphery. The extraposed relative clause has the same interpretation as the non-moved construction.

- (6) [DP *vo* [NP *kitab*] t_i] $\widehat{a\bar{t}h\bar{i}}$ *h\bar{e}* [RC $\widehat{d\bar{3}o\ sel\ p\bar{a}r\ h\bar{e}}$]_i
 that book.F.SG good.F.SG be.PRS.3.SG which sale on
 be.PRS.3.SG

‘That book is good which is on sale.’ [HINDI]

Dayal (1996) shows in great detail that the extraposed relative clause is a variation of the postnominal relative clause construction and does not have the same syntactic features as the correlative construction (cf. Srivastav 1991; Lipták 2009).

1.1.2 Correlatives

The primary focus of this dissertation is the correlative construction. The correlative strategization is characteristic of Modern Indo Aryan languages (Bhatt 2003), including Hindi and Marwari, and is employed in many other Indo-European languages as well (de Vries 2005). For a more in depth description of the correlative clause construction and how it differs from the postnominal relative clause, see Chapter 2.

Syntactically, correlatives have been described as as pairs of sentences (Davison 2009), with their own internal heads, and are marked as relatives by the presence of a relative pronoun. They are often described as occurring at the left periphery of the main clause, in a fronted position. (7a) and (7b) are examples of a typical correlative construction in Hindi and Marwari, respectively.

- (7) a. [CorrelCP $\widehat{d}\widehat{z}o$ *larkī* *kʰeɾi* *hɛ*] *vo*
 which girl.F.SG tall.F.SG be.PRS.3.SG that
lambi *hɛ*
 tall.F.SG be.PRS.3.SG
 'Which girl is tall, that/she is standing' (from Dayal 1996, p. 152) [HINDI]
- b. [CorrelCP $\widehat{d}\widehat{z}\widehat{a}ko$ $\widehat{i}^h\widehat{o}ri$ *ubi* *hɛ*] *ba*
 which girl.F.SG tall.F.SG be.PRS.3.SG that.F.SG
dig:i *ʔe*
 tall.F.SG be.PRS.3.SG
 'Which girl is tall, that/she is standing' [MARWARI]

Cross-linguistically, correlatives do not allow an external determiner, or external case marker or adposition (de Vries 2005).

In postnominal relative clauses, the head noun and the relative clause are both part of the same constituent. In correlatives, the relative phrase itself may include an NP component, the NP_{Cor}. For example, in (8) the relative phrase $\widehat{d}\widehat{z}o$ *sidi* 'which CD' is a constituent and is the subject of the correlative clause.

- (8) [CorrelCP [RelP $\widehat{d}\widehat{z}o$ *sidi*] *sel pər hɛ*]_i *maja*
 which CD sale on be.PRS.3.SG Maya
 [DemP *us* *sidi ko*]_i *kʰəɾidɛgi*
 that.OBL CD ACC buy.FUT.F.SG

'Which CD is on sale, Maya will buy that CD' (from Bhatt 2003, p. 486) [HINDI]

The internal head of the argument correlative (head_{RC}) is introduced by the relative pronoun or 'relative like determiner' $\widehat{d}\widehat{z}o$ 'who, which' and surfaces as an internal constituent of the relative clause itself. Cross-linguistically, the head_{RC} of internally headed relatives is usually in the argument position corresponding to the relativization site but can be preposed to the front of the relative clause (Bianchi 2002b).

The main clause of the correlative construction contains a demonstrative pronoun which corresponds with the internal head of the relative clause. In example (8), for instance, *vo* 'that' is a correlative pronoun associated with

the correlative clause *ā̄zo lar̄ki kʰar̄i h̄e* ‘which girl is standing’. Chapters 3 and 5 will discuss, in depth, the relationship between the correlative clause and the demonstrative in the main clause.

While the correlative construction is often treated as the primary relativization strategy in Hindi (de Vries 2001, 2005; Kachru 2006; Koul 2008), both prenominal and (extraposed) postnominal relatives are productive and common enough that it is hard to say with certainty whether they are truly ‘secondary’ relativization strategies as de Vries suggests.

1.1.3 Prenominal Relative Clauses

Prenominal relatives, or participials, precede the modified noun. They are often nominalized to a certain degree, and they can but are not required to be participial. Nor is it the case that all participial relatives are prenominal as was sometimes thought previously (de Vries 2005, p. 140).

Non-finite prenominal relatives are found in all Indo Aryan languages based on either a participial or adjectival form (Bhatt 2003).³ They are well-documented in Hindi (a few recent examples include Dayal 1996; Kachru 2006; Koul 2008) and are common in Marwari, also. Prenominal relative clauses in Hindi are non-finite, and the infinitive/gerundive clause agrees with the head in number, gender, and case (Dayal 1996, p. 152, footnote 2).

- (9) *us-ko* [*me-ri* [*kʰaridi* *hui*]
 that.S.OBL-DAT I.OBL-of.F.PL buy.PFV PTPL.F
 kitabe] *pasand nahĩ ati*
 book.F.PL liking NEG come.IMPFV.F.PL

‘(S)he does not like the books I buy.’ (*from* Kachru 2006, p. 229) [HINDI]

While this dissertation is primarily concerned with the correlative construction, I will discuss Hindi and Marwari prenominal, participial relatives and how they differ from the correlative construction briefly in Chapter 8.

3. Downing (1978, cited by de Vries 2005) suggests that the prenominal strategy universally excludes the correlative strategy. This does not prove to be the case, de Vries says, giving Hurric and Tamil as counterexamples. Correlatives are a primary relativizing strategy in most if not all Indo-Aryan languages. If Bhatt (2003) is correct in concluding that all Indo-Aryan languages use the prenominal relativization strategy, then nearly all Indo-Aryan languages (all of which also employ the correlative) are counterexamples as well.

1.2 Introduction to the Analysis

This dissertation will focus largely on the relationship between the correlative and the demonstrative in the main clause which it relates to.

Chapter 2 introduces the nominal correlative construction, for example (10), and its syntactic features. While the correlative is often associated with the left periphery, Bhatt (2003) shows that the Hindi correlative is base-generated within the same constituent as the demonstrative and may then raise from the demonstrative phrase to a fronted position.

- (10) [CorrelCP $\widehat{d}\zeta o$ $l\acute{a}rki$ $k^h\acute{e}r\acute{i}$ $h\acute{e}$] *vo*
 which girl.F.SG tall.F.SG be.PRS.3.SG that
 l\acute{a}mbi $h\acute{e}$
 tall.F.SG be.PRS.3.SG

‘Which girl is tall, that/she is standing’ (*from* Dayal 1996, p. 152) [HINDI]

I propose that the correlative clause is an overtly pronounced index of the demonstrative (Chapter 3). Rather than adjoining to IP (Dayal 1996) or above the demonstrative (Bhatt 2003), a correlative $\widehat{d}\zeta o$ $l\acute{a}rki$ $k^h\acute{e}r\acute{i}$ $h\acute{e}$ ‘which girl is standing’ enters the syntax as the indexical argument of the demonstrative phrase (Nunberg 1993; Elbourne 2008).

Most analyses of the correlative focus on the nominal correlative construction, where the nominal correlative relates to an argument in the main clause. I extend the discussion of correlatives to the adverbial correlative construction (see Chapter 4), where adverbial correlatives are headed by an adverbial relative phrase such as $\widehat{d}\zeta ah\tilde{a}$ ‘where’ in Hindi or $\widehat{d}\zeta it:o$ ‘how much’ in Marwari. An example of an adverbial correlative is (11), below.

- (11) [CorrelCP $\widehat{d}\zeta \acute{a}t^h\acute{e}$ $b^h\acute{i}r$ $r\acute{e}v\acute{e}$] $\widehat{t}^h\acute{o}ro$
 where_{RC} crowd.F stay.IMPV.PRS.3.SG boy.M.SG
 b^h\acute{a}t\acute{e} $\widehat{d}\zeta \acute{a}v\acute{e}$
 there go.IMPV.PRS.M.SG

‘Where a crowd gathers, (the) boy always goes there.’ [MARWARI]

I also present new data from Hindi and Marwari which shows that adverbial correlatives are a true correlative construction. I then show that the adverbial clause is not actually an adverbial but denotes an entity of type e.

to show that correlatives include a presupposition along with a discussion of the difficulty of obtaining these kinds of judgments through normal elicitation techniques.

The analysis which I present here for the correlative construction predicts that others types of phrases may enter the syntax as the indexical components of demonstratives and pronominals (Chapter 9). In this chapter, I show that not only are there other types of phrases in Hindi and Marwari which can act as indices in Hindi and Marwari, but the index can be overtly pronounced in other languages, as well. American Sign Language and Mandarin Chinese, for instance, do not have a correlative construction but both allow and index to be overtly pronounced.

1.3 Variation in Hindi and Marwari

There is a saying in Marwari that, if you go three kilometers, the taste of the water changes. Go six kilometers, and the language changes.⁴

- (13) *marwar mē hār ko? ũ paṇi bādā|e ne*
 Marwar.OBL from each kos in water.F change.IMPV.PRS.M.PL and
tin ko? ũ vaṇi
 three kos from language

'In Marwar, the water changes every 3 km, the language every 9.'

[MARWARI]

This is a very apt description of the language situation in India. Varieties within what is considered to be one language differ greatly – in some cases, so much so that they are not mutually intelligible.⁵ It is common for languages to show a great deal of variation even over small distances. This is partly

4. There are actually several variations of this saying in Marwari. Magier (1983) gives the version in (i). A kos equals approximately 3 km or 2 miles.

- (i) *barā kosā b^hasa bad|e tisā kosā mausim*
 twelve kos.OBL.M.PL language.M.PL change.FUT.3.PL thirty kos weather

'Language changes every twelve kos, weather every thirty.' (from Magier 1983, p. 5)

[MARWARI]

5. Here and throughout this chapter, I will use the terms *variety* and *dialect* interchangeably. The term *language* will be used for officially recognized languages or large language areas which may include a number of different varieties and dialects.

because travel in India is often difficult, and it is only in recent history that the majority of people have had access to vehicles. It is often especially difficult for women to travel alone due to cultural constraints. In Rajasthan and other parts of North India, it is still customary for a woman to cover her face with her or scarf whenever she is in the presence of a man who is not a family member. Thus, even within a small area it is possible for communities to remain segregated.

Language in India also varies according to identity. This includes identity based on religion, clan or regional affiliations, and caste, where caste not only refers to one's status in the Hindu religious system but also to one's community. The caste system not only relates to a hierarchal status, but also refers to a person's identity or people group within that hierarchy. In many parts of India, historically one's caste or community is related to a people's traditional occupation, and often only members of that caste are allowed to perform that particular job. Caste or community affiliation often dictates who someone is allowed to marry, where someone is allowed to worship, and even who someone is allowed to interact with. For this reason, different communities within the same region can speak very different varieties.

Many communities refer to their regional dialect according to their caste name, although this is not always consistent either. People may choose to affiliate themselves with prestigious languages such as Hindi. For this reason, it is quite common to have people groups who call their language Hindi, but the variety of language that they speak may actually be quite different from standard Hindi.

All of this is further complicated by the fact that, of the approximately 440 languages spoken in India (Lewis et al. 2016), only 22 of these are officially recognized by the Indian government. Thus the boundaries between languages not only varies according to caste religion, occupation, and region, but where language boundaries are drawn is also often a politically motivated decision.

Language identity and its relationship to community identity is somewhat different in Rajasthan compared to much of the rest of North India. In many areas of Rajasthan, when a person calls their language is often according to the region where they live and not the community that they belong to. This does not mean that language names are always consistent across regions, though. Historically, the regional boundaries within Rajasthan have varied according to the rulers at the time (the name Rajasthan means 'land of the kings.')

Names for language varieties may also relate to family names or caste names of famous rulers in a particular region, but people who are not of the same caste as that particular ruler may or may not choose to use this name (Magier 1983).

A large majority of the people in Rajasthan are multilingual. It is quite common for a person to speak one language at home, go to school in a different language, and to use yet another language in the market, at work, or when traveling to more heavily populated areas. Historically in India, the purpose of the language was not to achieve fluency but to perform a function, often within a certain domain (cf., Woolard and Schieffelin 1994; Mitchell 2005, 2006; Cameron 2006). A speaker may consider themselves fluent in Hindi if they are able to use it in the marketplace, for instance. Conversely, a speaker may be fluent in their first language or home language, even if they can only discuss topics which they learned in school, such as math and science, in English.

This does not mean that everyone in India is multilingual, at least not in the sense of that they are able to use more than one language proficiently in any given situation. The exceptions to multilingualism seem to be when a speaker already speaks a widely spoken, prestige language, such as Hindi, or when the speaker lives in a relatively homogenous rural area such as a village in Rajasthan.

1.3.1 Defining what is meant by Hindi

Because Hindi is an officially recognized language with high prestige there are many different language varieties whose speakers may call their language ‘Hindi’, not because of similarity but for reasons of identity. Most speakers across the Hindi belt of North India agree, though, that the ‘best’ variety of Hindi is Braj Bhasha. Braj Bhasha (which means, literally, Braj languages) is spoken in the Braj region centered on Eastern Rajasthan and the Mathura and Agra region of Uttar Pradesh (UP). This region also borders on the south and east of Delhi, the capital of India.

Throughout this dissertation, I will be looking at the variety of Hindi spoken in Delhi and the Lucknow/Meerut region of Uttar Pradesh UP, which is the region where Braj Bhasha is spoken. I worked primarily with one Hindi consultant, Hafiz.⁶ Hafiz, a 28-30 year old man, is a monolingual speaker of

6. Throughout the course of my fieldwork, I worked with three primary consultants, one in Hindi and two in Marwari, as well as several other Marwari speakers. Primary consultants

Hindi (or Hindi-Urdu), although he does know a little bit of English. He is Muslim, and refers to his language as both Hindi and Urdu interchangeably. Hafiz lives in the Nizamuddin region of New Delhi, but he grew up in the Lucknow/Meerut region of UP and continues to spend a significant amount of time there. He was educated up to 10+2 in UP in a Hindi medium school.

Much of the Hindi data presented here was double checked with other native, first-language speakers from Delhi and/or Meerut. Hafiz's judgments were also largely consistent with the data presented by Dayal (in Srivastav 1991 and Dayal 1996) as well as Bhatt (1997, 2003), Mahajan (2000), McCawley (2004), Kachru (2006), and Koul (2008), with only a few exceptions. Where Hafiz's judgments differed from these text with relation to the correlative construction has been noted as necessary.

Hafiz's judgments most often differed from other sources with relation to relative clauses of the right periphery of the main clause. In the variety of Hindi discussed by Dayal (1996), a relative clause at the right periphery cannot include an overt NP.

- (14) * *vo lərki ləmbi hε* [RC *d̪ʒo lərki*
 that girl.F.SG tall.F.SG be.PRS.3.SG which_{RC} girl.F.SG
kʰəɽi hε]
 standing.F.SG be.PRS.3.SG

Intended: 'The girl is tall, which girl is standing.' (from Dayal 1996, p. 160)
 [HINDI]

Hafiz's variety of Hindi, UP Hindi, allows an extraposed relative clause to include an overt NP. In this variety, both (14) above and the construction in (15) are entirely acceptable.

- (15) *ram ne (vo) tofa sita ko dija*
 Raam ERG that gift.M.SG Sita to.ACC give.PFV.M.SG
 [RC *d̪ʒo tofa vo ləndən se laja*]
 which gift.M.SG that London from bring.PFV.M.SG

'Ram gave that gift to Sita which he brought from London.' [HINDI]

were the speakers who I spent the most time with and who often helped me arrange sessions with other Marwari speakers.

All names used in the dissertation are pseudonyms.



Figure 1.1: The Marwar Region of Rajasthan, India

In this way, Hafiz’s variety of Hindi is more similar to the Hindi described by Mahajan (2000) and Kachru (2006). This difference does not affect the analysis of the correlative presented in this dissertation.

Additional Hindi data also came from other literary texts, primarily children’s books and some examples either taken or adapted from Hindi textbooks.

1.3.2 Three varieties of Marwari

While the language situation in Rajasthan is complex, people in Rajasthan are generally in agreement that the language spokenthroughout the Marwar (*marvar*) region is Marwari (*marvari*). The Marwar region itself encompasses the southwest part of Rajasthan, including Jodhpur district as well as Barmer, Jalore, Nagaur, and Pali districts (see figure 1.1). Most Marwari speakers agree that the standard variety Marwari, as far as it can be used considered standardized, is spoken in and around Jodhpur, the government seat of Jodhpur district (Magier 1983).

During the course of my fieldwork, I worked with approximately 12 different Marwari speakers, all from Jodhpur district. While each person's Marwari differed to some degree, for the most part each of the different varieties fell into one of three categories according to which region of Jodhpur district the speaker was from. The three varieties are listed below.

(16) Varieties of Marwari discussed in this dissertation:

1. Jodhpuri Marwari, or simply Marwari
2. Khariya Mithapur (KM) Marwari
3. Osian Marwari

Jodhpuri Marwari, which I will refer to as simply Marwari, includes the varieties spoken in and around Jodhpur city itself. Other areas where Jodhpuri Marwari is spoken include Sangaria, a suburb of Jodhpur 12 km south of the city center, and Sarechan,⁷ a small village approximately 30 km south of Jodhpur. I was able to work with six different speakers of Jodhpuri Marwari, including one of my primary consultants, Sunil. Sunil is a 38-year-old Christian man from a Hindu background, originally from Sangaria with family in Sangaria and Sarechan, whose education was in Hindi.

Other Jodhpuri Marwari speakers who I met with less frequently ranged between 18 and 35 years of age. Two of the speakers were women, one of whom belongs to the Rajput community. The other four speakers were men between the ages of 20 and 40, all of whom were designated as schedule caste. One of the men was from Sarechan, and the others were all from Jodhpur city. Education levels varied. Both of the women have studied at university level, while the men ranged from 9th pass to PhD.⁸ Because only three of the Jodhpuri Marwari speakers also speak English, most of our sessions were conducted in Hindi.

My second primary consultant, Kartik, lives and works in Jodhpur city but is originally from Khariya Mithapur, a village approximately 80 km east

7. Sarechan is sometimes also spelled Sarencha.

8. The Indian school system largely follows the British school system and has a '10+2+3' pattern of education. A basic primary and secondary school education is through 10th standard. This is followed by two years of junior college. This is equivalent to college in the UK or the last two years of senior high in the US. Most bachelor degree programs are three year programs.

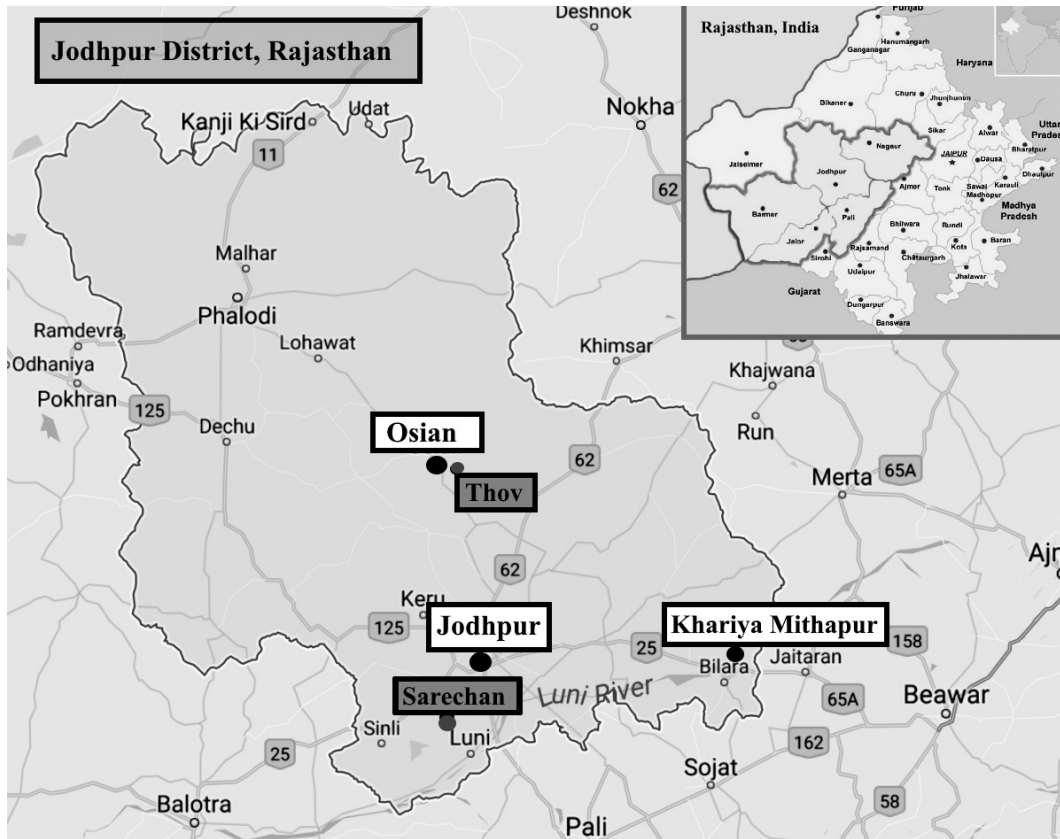

Figure 1.2: Jodhpur District, Rajasthan.

of Jodhpur in Bilara Tehsil⁹ of Jodhpur district. The variety of Marwari spoken in Khariya Mithapur (KM) is very similar to the variety of Marwari spoken in Jodhpur city, with only a few differences. Where KM Marwari differs from other varieties of Marwari is noted where appropriate. Kartik is well educated with a bachelors of arts as well as a BA, LLB, and his higher education was in English medium. He speaks both English and Hindi, although he is more comfortable with Hindi than he is with English, and most of our sessions were conducted in a combination of English and Hindi.

The third variety of Marwari I look at in this research is Osian Marwari. Osian, with a population of approximately 12,500 people, is an important town and oasis in the Thar Desert. Osian itself is the headquarters of Osian Tehsil of Jodhpur district and is approximately 70 km north of Jodhpur. I worked with two Osian Marwari speakers, Sanjay and Raj, who were from the town of Osian and from Thov village, respectively. Sanjay and Raj are both

9. A tehsil is a political subdivision of a district which usually has a city or town as its administrative center.

schedule caste/scheduled tribe. Both were educated in Hindi, and all of our sessions were conducted in Hindi. Osian Marwari is syntactically similar to both Jodhpuri Marwari and KM Marwari, but there are some morphological and vocabulary differences. For instance, the Osian Marwari word for sentence negation is *ko*, whereas sentential negation is either *koni* or *ni* in the other varieties of Marwari. Osian Marwari also differs in its agreement patterns both on noun phrases and verbal agreement.

Readers familiar with Hindi and other MIA languages might note that Marwari verbal agreement is not always with the subject. Marwari does not have overt ergative case marking, but in Marwari agreement with the subject is blocked when the verb is marked by perfective aspect. This is likely due to covert ergative case marking on the subjects when the predicate is perfective and transitive.

For more information on the methodology used in this research, see Chapter 8. See also Appendix A for a short description of Marwari grammar.

1.4 Other topics not covered

Correlatives are worth in-depth investigation and involve many different constructions and grammatical devices which affect their syntax and their semantic contribution. There are some aspects of the correlative construction and some related constructions which, while very interesting and in many ways relevant to the discussion at hand, simply cannot be discussed with the amount of attention that they deserve in this limited amount of space. In this section, I outline several topics which are relevant to the correlative construction but which will not be discussed as part of this dissertation.

1.4.1 The postnominal relative pronoun

Throughout the discussion of the correlative and its semantic contribution, it is important to keep in mind that the relative pronoun in correlatives and free relatives is not the same as the relative pronoun in postnominal relative clauses. It is tempting to analyze both correlative relative pronouns and postnominal relative pronouns as the same lexical item, or at least a very similar one. Bianchi (2002a, p. 197) for example concludes that, despite the various syntactic mechanisms employed, ‘each type of relativization is a unitary phe-

nomena at the semantic level' (see also Keenan and Comrie 1977). Certain syntactic analyses of the correlative and postnominal relative constructions assume that they are underlyingly the same construction, therefore implying that the semantic contribution of them both must be the same as well (Kachru 1973, 2006; Mahajan 2000).

It is misleading that the correlative relative pronoun and the postnominal relative pronoun are often homophonous. This is so common that they appear to always be the same morpheme de Vries (2005). If it were the case that the correlative relative pronoun and the postnominal relative pronoun are always homophonous and that all types of relativization are the same at the semantic level, it still would not be a sufficient argument that they are the underlyingly the same, as there are many syntactic and semantic differences.

It is not universally true, though, that the correlative pronoun and the postnominal relativizing morpheme are necessarily the same. Historically, correlatives and postnominal relative clauses have arisen separately (though not necessarily independently), and there have been several points in history where the correlative and the postnominal relative have been different (Truswell and Gisborne 2016). A more modern example is the Modern English *that*, which may be used as a relativizer in postnominal relative constructions but cannot head a free relative.

Another consideration is that correlative constructions are predominantly an IE phenomenon, so it is not surprising that many of them follow the same pattern in using a similar morpheme for both the correlative relative pronoun and the postnominal relative pronouns. Additionally, there are non-IE languages which have correlatives do not have postnominal relative clauses at all. Dravidian languages, for example, do not usually have postnominal relative clauses (Krishnamurti 2003; Hendery 2012).

While the postnominal relativizer and the *wh*-phrase in correlatives are related, and probably include many of the same components, they are not equivalent. For this reason, I will not assume that the postnominal relative clause has the same semantic contribution as the correlative *wh*-phrase. The analysis for the correlative relative pronouns presented here is in no way intended to say anything about the semantic contribution of the postnominal relative pronouns.

1.4.2 Free choice correlatives

When the relative phrase of a correlative construction includes the polarity sensitive item *b^{hi}*, the correlative clause has a Free Choice reading similar to the reading associated with the morpheme *-ever* in English free relatives (Dayal 1996, 1997). In (17), for example, the relative phrase *ḍ̣̌ḍ̣̌o b^{hi} ləṛki* is most accurately translated as ‘whichever girl.’

- (17) [CorrelCP *ḍ̣̌ḍ̣̌o b^{hi} ləṛki mehnət karti he*]
 which ever girl.F.SG effort.F.SG do.IMPV.F.SG PRS.3.SG
 vo safal hoti he
 that successful be.IMPV.F.SG PRS.3.SG

‘Whichever girl makes an effort will succeed.’

Lit.: ‘Whichever girl makes an effort, that is successful.’ (*from*

Dayal 1996, p. 211)

[HINDI]

Like English *-ever*, a relative phrase of this type can give both a generic reading similar to *any girl* or a specific reading in which there is one, unnamed girl who will be successful if she works hard.

The Free Choice reading is also available for correlatives involving adverbial relative phrases, such as the correlative clause in (18).

- (18) [CorrelCP *ḍ̣̌ḍ̣̌əde b^{hi} mē ḍ̣̌ḍ̣̌auḷa*] *t^həde (mē) ṭ̌ɔklət*
 where ever I go.FUT.1.SG there I chocolate.M
 lauḷa
 carry.FUT.1.SG

‘Wherever I go, I take chocolate (with me).’

[MARWARI]

Just as in other correlative constructions, the availability of the generic, Free Choice reading is dependent on tense and aspect. For example, Hindi allows two different conjugations of the verb *ho* ‘to be.’ The first, *he* marks the simple present. If the verb form is *he*, then the generic reading is unavailable and the sentence is a statement about only one individual as defined by the correlative clause (Dayal 1996). In (19), there can only be one girl who is standing. Whichever girl that is, she is Ravi’s friend.

- (19) [CorrelCP *d̄ʒo bʰi ləɾki vəhã kʰəɾi hɛ*] *vo*
 which ever girl.F.SG there standing.F.SG be.PRS.3.SG that
rəvi ki dost hɛ
 Ravi of.F.SG friend.F.SG be.PRS.3.SG

'Whoever is standing there is Ravi's friend.'

'Whichever girl is standing there, that is Ravi's friend.' (*from*

Dayal 1996, p. 211) [HINDI]

The other verb form, *hoti hɛ*, is the present imperfective. If the verb form is *hoti hɛ*, such as in (20) then the generic reading is available.

- (20) [CorrelCP *d̄ʒo ləɾki tez hoti hɛ*] *vo əksar*
 which girl.F.SG quick be.IMPFV.F.SG PRS.3.SG that often
səfəl hɛ
 successful be.PRS.3.SG

'The girl who is smart is often successful.'

Lit.: 'Which(ever) girl is smart, she is often successful.'

(*from* Dayal 1996, p. 209) [HINDI]

English show the same kind of variation according to the tense and aspect of the verb phrase. The English sentence (21) allows a free choice reading, and can be interpreted as the speaker bringing coffee back from any number of places they have visited.

- (21) Wherever I go, I always bring back coffee.

Unlike (21), (22) can only refer to one unnamed or unknown individual.

- (22) Wherever John went over his vacation, I bet it wasn't very nice.

The only available interpretation of (22) is that John went somewhere on vacation, and that (single) location was not a very nice place to visit.

While important, Free Choice items in correlatives is not something which will be discussed in this dissertation but will be left for further research.

1.4.3 Relative constructions at the right periphery

Analyses differ as to whether correlatives must be restricted to the left periphery or may also occur at the right periphery. De Vries (2004:134) defines

correlatives as either preposed or left-adjoined to the main clause at the left periphery, but Dayal (1996:152) states that ‘[t]he ability of relative clauses to appear at either edge of the clause may therefore be taken as the defining characteristic of languages with correlatives.’ Although she later goes on to argue that most rightward relatives in Hindi are rightward extraposed postnominal relatives, she does allow for the less common right-adjoined correlatives. Kachru (2006) also defines correlatives as those relatives which either precede or follow the main clause and which are distinct from the post-head (*i.e.*, postnominal) position, but she assumes correlatives are base-generated as postnominal relative clauses.

Dayal (1996) gives one sentence, repeated below, which she analyzes as a correlative at the right periphery.

- (23) *bəʈʃʰ:e* *kʰel rəhe* *tʰe* [CorrelCP *dʒis*
 children.M.PL play PROG.M.PL PAST.M.PL which.OBL.SG
ki *avaz* *a* *rəhi* *tʰi*]
 of.F.SG voice.F come PROG.F.SG PAST.F.SG

‘The sounds of children playing was coming in.’

Lit.: ‘Children were playing, whose sound was coming in.’ (*from*

Dayal 1996, p. 172)

[HINDI]

Neither my Hindi nor my Marwari consultants would accept this sentence (or its Marwari equivalent), stating that *dʒo* ‘which’ must have the plural oblique form *dʒim* because it can only refer to the children, not the sound.

Dayal translates (23) as ‘Children were playing, whose sound was coming in’. It is possible that the relative clause in (23) is actually modifying the entire main clause *bəʈʃʰ:e kʰel rəhe tʰe* ‘children were playing’ (Rajesh Bhatt, p.c.). If this is the case, then a more accurate translation might be ‘The children were playing, the sound of which was coming in (to the room)’ or, more loosely, ‘the sound of the children playing was coming in’. (23) might have been more acceptable to my consultants with this interpretation.

Even if it is possible for a correlative clause or a free relative to occur at the right periphery of the main clause, this is a variation of the correlative construction which I do not consider in this dissertation. I instead assume that a true correlative clause can only occur at the left periphery, and a relativizing clause at the right periphery must be some other type of construction. One evidence that this is correct is that the extraposed relative clause does not

have pattern with the correlative clause but has the same binding effects as the postnominal clause. If correlatives at the right periphery were allowed, we would expect these binding effects to be ambiguous, which is not the case. So, either a correlative at the right periphery is highly restricted or it is not possible at all, at least in some varieties.

1.4.4 If-then variations on the correlative construction

Bhatt and Pancheva (2002) suggest that if-then constructions such as those found in English are underlyingly a correlative construction. Like the correlative construction, the if-then construction involves an embedded CP which relates to the main clause through a correlate – *then*, in this case. In correlativizing languages such as Marathi, if-then statements are syntactically very similar to the correlative construction.

- (24) *(dzar) tyane ab'as kela tar to pa hoil*
 if he studying do.PST.3.M.SG then he pass be.FUT.3.SG

'If he studies, then he will pass (the exam).' (*from* Pandharipande 1997,
cited by Bhatt and Pancheva 2002, p. 5) [MARATHI]

While this is a novel approach to if-then constructions, it is not without precedent. It has previously been noted that conditional clauses, like free relatives, have the same interpretation as plural definite descriptions (Jacobson 1995; Caponigro 2003; Caponigro et al. 2012). I show in Chapter 6 that correlative clauses have this same interpretation.

There are other constructions which seem to be similar to both if-then clauses and correlatives. Lhasa Tibetan, for instance, has a construction which looks like a correlative (Cable 2009). An example of this construction is shown in (25).

- (25) [*k'yodra- s gyag gare nyos yod na*] *nga- s*
 you ERG yak what buy AUX if I ERG
de bsad pa yin
 that kill PFV AUX

'I killed whatever yak you bought.'

Lit.: 'If you bought what yak, I killed that.' (*from* Cable 2009, p. 195)

[LHASA]

In (25), the embedded CP includes both a *wh*-element *gare* and a morpheme *na* which Cable glosses as ‘if’. Further, Cable (2009, p. 198) states that the embedded CP has ‘some form of construal-like relationship a demonstrative phrase in the matrix clause.’

Tibetan correlative clauses are not like free relatives nor are they actually conditionals. Cable (2009) notes that the status of *na*, glossed as ‘if’, is somewhat unclear. It appears in conditional clauses, but its use in the Tibetan correlative construction is not consistent with an *if*-clause interpretation. He ultimately concludes that the Tibetan correlative is a true correlative construction but it is able to enter the syntax by adjoining to IP or adjoining to the demonstrative phrase.

While such variations on the more proto-typical correlative construction are constructions which bear researching further, both if-then clauses and the Tibetan correlative, which also seems to employ a conditional particle, are sometime which will have to be left to later research.

Importantly, this means that when I discuss Adverbial Correlatives in Chapter 4 and Chapter 5, and how they are different from other adverbial constructions, I am not including if-then constructions in this as there is evidence that they do pattern with correlatives.

1.4.5 (Clausal) Comparatives

Another apparent variation on the correlative construction is the clausal comparative. MIA languages have two types of comparative constructions. The first, a phrasal comparative or three-place comparative takes two NPs and compares them with reference to a single predicate.

- (26) *hat^{hi} gaj ã gəŋo mət^ho ʔε*
 elephant.M.SG cow.OBL.M.SG SRC very.M.SG big.M.SG be.PRS.3.SG
 ‘(An) elephant is bigger than (a) cow.’ [MARWARI]

The second comparative construction involves a degree clause or what is really a degree correlative clause which enters the syntax via a demonstrative. For example, in (27), the degree correlative clause *ãʒito dig:o b^halu hε* ‘how tall a bear is’ relates to the main clause through the oblique demonstrative *un* ‘that’. The main clause compares the height of the giraffe to the height of the

base word order position at the left or right periphery of the main clause. (cf. Mahajan 1994, 2000; Dayal 1996; Kidwai 2000) This happens so frequently and so freely that it is often described ‘free word order variation’ (Dwivedi 1994). (28) is the base word order for Marwari.

- (28) *raam sita ne ek tofu diyo ho*
 Raam Sita ACC one gift.M.SG give.PFV.M.SG PST.M.SG
 SUBJ IO DO V AUX
 ‘Ram gave a gift to Sita.’ [MARWARI]

All of the following variations, as well as several others, of the word order found in (28) are available.

- (29) a. [*sita ne*]_i *ram t_i ek tofu diyo ho*
 Sita ACC Raam one gift.M.SG give.PFV.M.SG PST.M.SG
 IO SUBJ DO V AUX
 ‘To Sita, Ram gave a gift.’ [MARWARI]
- b. [*ek tofu*] *ram sita ne t_i diyo ho*
 one gift.M.SG Raam Sita ACC give.PFV.M.SG PST.M.SG
 DO SUBJ IO V AUX
 ‘A gift, Raam gave to Sita.’ [MARWARI]
- c. *ram t_i t_j diyo ho [ek tofu]_j*
 Raam give.PFV.M.SG PST.M.SG one gift
 SUBJ V AUX DO
 [*sita ne*]_i
 Sita ACC
 IO
 ‘Raam gave one gift to Sita.’ [MARWARI]

Because the term *scrambling* has been used to mean different things for different languages or under different types of analyses, I avoid using it in this text. Instead, I will simply refer to the *fronting* of an argument or adverbial phrase to mean when the phrase is raised to a high position and pronounced preceding the rest of the sentence. It is also possible for rightward scrambling to the right periphery to occur, but this is less common and far more restricted (Mahajan 1994; Bhatt and Dayal 2007).

Accounts vary regarding the semantic contribution of scrambling, but most agree that scrambling either marks topicality or focus.

Scrambling and the fronting of arguments and adverbials is a significant topic in its own right, but it is not something which I will attempt to address in this dissertation.

Chapter 2

The nominal correlative

2.1 Looking ahead

In this chapter, I look at the syntactic features of the nominal correlative construction. The nominal correlative includes correlative clauses which are headed by the nominal relativizer $\widehat{d}3o$ and $\widehat{d}3\partial ko$ ‘which, who, that’ in Hindi and Marwari respectively.

The correlative is one of several relativization structures available cross linguistically. It is largely characterized as a relative clause which appears at the left periphery of the main clause and which is linked with the main clause through a nominal correlate, an associated demonstrative phrase which it may or may not be adjacent to.

Nearly all modern Indo-Aryan languages have correlative constructions¹, and the correlative is well documented in the ancient Indo-European (IE) languages, Modern Indo-Aryan (MIA), and Slavic languages. There are a few non-Indo-European languages which also have correlatives such as Bambara, Basque, Hungarian, and arguably Tibetan (Cable 2009). Several Dravidian languages also have correlative constructions, as does Burushaski (an isolate spoken in northern India), arguably due to contact with Indo-Aryan languages. (Bhatt 2003; de Vries 2005; Lipták 2009)

In Section 2.2, I outline the terminology I use throughout the dissertation and summarize the typical features of the correlative construction as outlined by Dayal (1996), Bhatt (2003), and Lipták (2009).

1. Exceptions as noted by Bhatt (2003) include Southern Konkani, Saurashtri, and Sinhalese. Masica (1993) comments that he only found postnominal and extraposed relatives in Kashmiri, but Wali and Koul (1997) include examples of Kashmiri correlatives.

Section 2.3 includes a summary of some recent analyses of the correlative construction. Dayal (1996) shows that the correlative is a distinct construction from the postnominal relative clause and argues that the correlative adjoins to IP (Section 2.3.1). Bhatt (2003) challenges the assumption that the correlative adjoins to IP and shows that, instead, it is base-generated as part of the same constituent as the demonstrative phrase (Section 2.3.2). This is the analysis which I assume, as well.

2.2 The Correlative Cross-Linguistically

Following is an example of a correlative construction in Hindi. The correlative clause $\widehat{d}ʒo$ $ləʃki$ $k^hɛʃi$ $hɛ$ ‘which girl is standing’ relates to the main clause through the demonstrative vo ‘that’,² where the relativizing clause is marked with brackets.³

- (1) [_{CorrelCP} $\widehat{d}ʒo$ $ləʃki$ $k^hɛʃi$ $hɛ$] vo
 which girl.F.SG standing.F.SG be.PRS.3.SG that

 $ləmbi$ $hɛ$
 tall.F.SG be.PRS.3.SG

‘The girl who is standing is tall.’

Lit.: ‘Which girl is standing, that is tall’ (*from* Dayal 1996, p. 152) [HINDI]

Like Hindi, the correlative construction in Marwari and Bangla also involves a relative clause which is associated with a demonstrative in the main clause. Examples include (2) and (3).

2. Unless noted otherwise, Hindi and Marwari data comes from my own fieldwork in New Delhi and Jodhpur, Rajasthan, respectively. Most Hindi and Marwari examples from other sources have been rechecked with my informants as well. The Marwari variety represented here is that spoken in Jodhpur, Rajasthan. Hindi and Marwari data is in IPA, including when the data is from other sources. Other examples are in the author’s transcription, but the glossing has been standardized. Leipzig glossing conventions are used throughout, with a few exceptions. See the List of Abbreviations for more details.

See Chapter 1, Section 1.3, for a discussion of the varieties of Marwari and Hindi included in this research.

3. Throughout this paper, I give a more literal translation which reflects the structure of the language being translated as closely as possible. I am not assuming that all free translations will be entirely acceptable in English.

2.2.1 Terminology

The terms used for the different elements of the correlative construction are not always consistent, differing by theory, author, and type of treatment. The term ‘correlative’ was not always restricted to relatives at the left periphery. Because the most commonly used terminology is based on assumptions about the structure of the correlative which have been shown in more recent work to be inaccurate, I have chosen to use these terms in a slightly different way than other authors might have used them.

In earlier work, the relativizing clause in correlative constructions is called the *relative clause*, and the demonstrative/pronominal in the main clause the *correlative*. Because the use of ‘relative clause’ to refer to the correlative often assumed that it comes from a postnominal relative position (after the associated noun), an assumption which several more recent analyses have argued to be incorrect, I refer to the relativizing clause the *correlative*. Cross-linguistically the demonstrative or pronominal marking the relativized argument is no different from a demonstrative outside of the correlative construction, and there is no evidence that it is internally different from other indexicals. For this reason, I refer to the indexical in the main clause which relates to the correlative as the *correlate* or *correlative clause* rather than the *correlative* as is often called.

Given an example like the following, $\widehat{d}\text{ʒo } l\text{ərki } k^h\text{e}\text{r}\text{i } h\text{e}$ ‘which girl is standing’ is the correlative (in square brackets) and the demonstrative *vo* ‘that’ is the correlate.

- (6) [CorrelCP $\widehat{d}\text{ʒo } l\text{ərki } k^h\text{e}\text{r}\text{i } h\text{e}$] *vo* (*l\text{ərki}*)
 which girl.F.SG standing.F.SG be.PRS.3.SG that girl.F.SG
 l\text{əm}bi *h\text{e}*
 tall.F.SG be.PRS.3.SG

‘Which girl is standing, that girl is tall’ [HINDI]

Correlatives are headed by a relativizing *wh* or *relative pronoun*. The relativizing pronoun in Hindi, Marwari, and other MIA languages is phonologically distinct from the interrogative *wh* (*wh_Q*). For example, the interrogative *wh*-phrases are *kja* ‘what’ and *kajĩ* ‘what’ in Hindi and Marwari respectively (underlined and marked as interrogatives by the subscript Q), as shown in (7). (8) includes examples of correlative constructions in Hindi and Marwari. The

relative clause like (9) is externally headed and there is only one associated nominal, \widehat{t}^{hori} ‘girl’, the nominal is often called the *head* or *external head* of the relative clause.

- (9) *va* \widehat{t}^{hori} [_{RC} $\widehat{d}\mathfrak{z}\partial ko$ *ubi* *h\epsilon*]
 that.F.SG girl.F.SG which standing.F.SG be.PRS.3.SG

dig:i *h\epsilon*
 tall.F.SG be.PRS.3.SG

‘That girl who is standing is tall.’

[MARWARI]

In some cases, authors have referred to the NP in the wh_{RC} -phrase and the NP in the demonstrative phrase both as the head of the correlative construction (Dayal 1996; de Vries 2001, 2005; Bianchi 2002a,b). It can then be unclear whether this is in reference to the NP in the relative phrase or the NP in the correlative phrase. Further, while it may be argued that the modified noun in postnominal RC constructions such as (9) is the syntactic head, this is not accurate in the correlative construction. For this reason, I refer to the NP in the wh_{RC} -phrase in the correlative as the NP_{Cor} and the NP in the demonstrative phrase of the main clause (MC) as the NP_{MC} .

A correlative construction, therefore, has a structure something like (10), below, where the indexation indicates a relationship between the correlative clause and the demonstrative.

- (10) [_{CorrelCP} ... [_{RelP} WH_{Cor} NP_{Cor}] ...] [_{MC} ... [_{DemP} Dem NP_{MC}] ...]

The rest of this chapter will look more closely at the internal structure of the correlative construction, particularly the relationship between the correlative clause and the demonstrative phrase in the main clause.

2.2.2 Defining Features of the Correlative Construction

The correlative construction is often discussed in contrast with the postnominal relative clause (sometimes called the restrictive relative clause), which follows the associated noun and has the semantics of a modifier (11).

- (11) $\emptyset/ek/koi/vo$ $l\grave{a}rki$ [$\widehat{d}\zeta o$ $k^h\grave{a}r\acute{i}$ $h\epsilon$]
 a/one/some/that girl.F.SG which standing.F.SG be.PRS.3.SG
 $l\grave{a}mbi$ $h\epsilon$
 tall.F.SG be.PRS.3.SG

`A/one/some/that girl who is standing is tall. [HINDI]

The correlative construction is widely accepted as having the following features (Srivastav 1991, Dayal 1996, Bhatt 2003, Lipták 2009). I am leaving aside for now constructions which may or may not be correlatives or which are specialized variations of correlatives such as comparatives and conditional clauses.

- (12) Typical features of a correlative construction:
- (a) Occur at the left periphery of the main clause.
 - (b) Headed by a relative pronoun or wh_{RC} .
 - (c) The relativized nominal may appear in both the relative clause and the correlative (what Dayal 1996 calls *headedness*).
 - (d) There must be a correlate, either a demonstrative or a pronominal, in the main clause (the *demonstrative requirement*, from Dayal 1996)
 - (e) Correlatives license multi-headed relative clauses.

Postnominal relative clauses differ from correlatives in that they are not fronted but follow the relativized nominal, they are not subject to the demonstrative requirement, they cannot be internally headed, and they do not license multi-headed relative clauses (Srivastav 1991; Dayal 1996, Ch. 5-6).

I discuss the features of the correlative construction in more depth in the rest of the section.

2.2.2.1 Are correlatives truly peripheral?

The correlative construction is generally defined as a correlative clause occurring at the left periphery of the main clause (12a, above). The correlative is so closely associated with the periphery that Dayal (1996) calls this ‘[t]he chief characteristic associated with correlative constructions’. Thus, the word order

seen in the examples so far is often assumed to be the base word order for correlative constructions (Ivzorski 1996; de Vries 2001; de Vries 2005; Lipták 2009).

Many of the correlative examples presented in the literature, including both formal treatments and descriptive grammars, relate to the subject of the main clause. This obscures the fact that, despite appearances, the correlative is not necessarily limited to a sentence initial, peripheral position. Bhatt (2003) shows that, where the corresponding noun phrase is not at the beginning of the main clause, the correlative may surface at the position of the correlate itself. For example, in (13) the correlative *ḍ̄ʒo sidi sel pər hɛ* ‘which CD is on sale’ surfaces inside of the main clause, following the main clause subject, immediately preceding the demonstrative phrase *us sidi ko* ‘that CD’.⁴

- (13) *raam* [*ḍ̄ʒo sidi sel pər hɛ*] *us sidi ko*
 Raam which CD sale on be.PRS.3.SG that.OBL CD ACC
kʰaridɛga
 buy.FUT.3MS

‘Raam will buy which CD is on sale, that CD.’ (*adapted from*
 Bhatt (2003, p. 490)) [HINDI]

The correlative may also optionally be fronted (example 14), and therefore separated from the correlate (*us sidi ko* ‘that CD’) in the surface word order.

- (14) [*ḍ̄ʒo sidi sel pər hɛ*] *raam us sidi ko*
 which CD sale on be.PRS.3.SG Raam that.OBL CD ACC
kʰaridɛga
 buy.FUT.3MS

‘Which CD is on sale, Raam will buy that CD.’ [HINDI]

From this, it is clear that the correlative clause does not necessarily have to be fronted but may be pronounced immediately preceding the correlate phrase. What implications this has for the analysis of the correlative construction will be looked at in depth in Section 2.2.2.1.

4. I avoid using the term ‘embedded’ here because I am assuming that the correlative, even when raised, is embedded within at least the highest CP of the main clause and is therefore embedded within the MC even when it is at the periphery.

2.2.2.2 The relative phrase of the correlative

Hindi and Marwari are both *wh*-in-situ languages, and like the *wh*_Q, the correlative *wh*_{RC} may remain in-situ as well. Masica (1993), for instance, notes that the ‘*ḍ*-element’ (i.e., the relative pronoun) does not have to come at the beginning of the correlative clause. Examples of correlatives with in situ relative phrases are shown in (15) and (16) for Hindi and Marwari respectively. The relative phrase is underlined.

- (15) [_{CorrelCP} *mudḍ^{he} ḍḍo larkī pasənd he*] *vo larkī*
 I.DAT which girl.F.SG liking be.PRS.3.SG that girl.F.SG
aegi
 come.FUT.F.SG

‘The girl who I like is going to come.’

‘I like which girl, that girl will come.’ [HINDI]

- (16) [_{CorrelCP} *polis ḍḍin t̪^{ori} ne pakāda legi*]
 police which.OBL.SG girl.OBL.F.SG ACC catch take.LGT.PFV
raam ne va t̪^{ori} pasənd he
 Raam DAT that.F.SG girl.F.SG liking be.PRS.3.SG

‘Raam is in love with the girl that the police caught.’

Lit.: ‘The police caught which girl, Raam loves that.’ [MARWARI]

In this way, correlatives differ from the postnominal relative clause which does not allow the *wh*-phrase to remain in situ. In (17), for example, the relative phrase must precede the rest of the postnominal relative clause (RC) in order to be grammatical (18).⁵

- (17) * (*vo*) *larkī* [_{RC} *mudḍ^{he} ḍḍo pasənd he*] *aegi*
 that girl.F.SG I.DAT which liking be.PRS.3.SG come.FUT.F.SG

Intended: ‘That girl who I like will come.’ [HINDI]

5. The Hindi sentence in (17) is grammatical with an appositive reading but is not acceptable with a postnominal RC reading.

- (18) *(vo) lərki* [RC *d̂ʒo mud̂ʒʰe pəsənd hɛ*] *aegi*
 that girl.F.SG who I.DAT liking be.PRS.3.SG come.FUT.F.SG
 'That girl who I like will come.' [HINDI]

Whether the relative phrase of the correlative is interpreted in situ or raises to LF to give the clause its correlative interpretation is discussed in depth in Chapter 6, Section 6.3.

2.2.2.3 Dual Headedness

Correlatives differ from postnominal relatives in that they are exempt from what I will call the *headedness restriction* (adapted from Dayal 1996). The headedness restriction states that the modified nominal may not appear overtly inside of a postnominal relative clause and applies cross-linguistically. The correlative construction, on the other hand, allows an NP to emerge both at the relative phrase and at the demonstrative phrase.

Dayal (1996) refers to the overt pronunciation of the nominal within a clause as *headedness*, defining it as the presence or absence of the common noun in the relative clause and/or the matrix clause. For now, I use the term headedness in the same way while stipulating that this is an entirely descriptive term without taking any theoretical stance at this point. I revisit what it means for the correlative to be headed in this way in the next chapter.

- (19) *The Headedness Restriction:*

A correlative may be headed by, or contain an overt copy of, the relativized NP within the relativizing clause itself, but a postnominal relative clause may not (adapted from Dayal 1996).

A postnominal relative cannot be headed inside of the relative clause. As (20) shows, this is the case for both English and Hindi.

- (20) a. The girl who (*girl) is standing is tall.
 b. *vo lərki* [*d̂ʒo (*lərki) kʰəɽi hɛ*]
 that girl.F.SG who girl.F.SG standing.F.SG be.PRS.3.SG
ləmbi hɛ
 tall.F.SG be.PRS

Intended: 'The girl who girl is standing is tall.' [HINDI]

Unlike postnominal relatives, correlatives allow the associated nominal to surface in the correlative clause and/or the main clause.⁶ For example, in the following, the nominal *larkī* ‘girl’ may appear in the correlative *wh_{RC}*-phrase, in the associated demonstrative phrase, or both.⁷

- (21) [*ḍ̄ʒo* (*larkī*) *kʰaɾi* *hɛ*] *vo* (*larkī*)
 which girl.F.SG standing.F.SG be.PRS.3.SG that girl.F.SG
lambi *hɛ*
 tall.F.SG be.PRS

‘Which girl is standing, that (girl) is tall.’ [HINDI]

There are differing analyses as to what allows a NP to emerge both in the relative phrase of the correlative and the demonstrative phrase of the main clause. Some authors refer to one or the other noun as a ‘copy’, without always making it clear which noun is a copy of the other (de Vries 2005). Other authors argue for deletion of (Koul 2008) or non-realization of (Kachru 2006) one or the other NP. Yet others refer to restrictions on spell-out (Lipták 2009; Mahajan 2000) where one or the other (or both) instance of the nominal may be overtly pronounced.

Throughout the literature, with only a few exceptions (Srivastav 1991; Dayal 1996; McCawley 2004; Potts et al. 2009), it is assumed that the NP_{Cor} and the NP_{MC} must be the same. In my own field work, I found that both the *wh_{RC}*-phrase and the DemP may include a different noun as long as there is a clear relation between them.⁸

Potts et al. (2009) note that Hindi allows the NP_{MC} and NP_{Cor} to differ, but argue that this can only occur if the NP_{MC} is an expressive, such as *harami*

6. Dayal (1996, p. 159, footnote 9) notes that in Kachru (1973, 1978) correlative constructions which include both a NP_{Cor} and NP_{MC} have a question mark. In a later work, Kachru (2006, p. 220) describes correlative constructions as having ‘zero realization’ of the head noun (i.e., the NP_{MC}), but later in the same book (p. 222) she notes that ‘it is not obligatory to have zero realization of either the relativized or the head noun. It is grammatical to have both the nouns lexically realized’, giving two examples of this.

Dayal also points out that she considers a correlative construction with a NP_{Cor} and no NP_{MC} to be more basic and the other variations to be more marked.

7. This is also grammatical without *larkī* ‘girl’ in either clause, but means ‘who_{FEM} is standing_{FEM}, that is tall_{FEM}’, and can refer to anything which is feminine.

8. McCawley 2004 gives some examples of correlative constructions which include different NPs in the relative phrase of the correlative clause and the demonstrative phrase of the main clause. Bhatt (2003) and Dayal (1996), who both assume that the correlative is an independently generated clause, also include examples of this type but do not discuss the availability of different NPs in depth.

'bastard' in (22), below.

- (22) [_{CorrelCP} *d̄ʒɪs* *admi* *se tum bəhət pjar se bat kər rəhe*
 which man.M.SG with you much love with talk do PROG.M.PL
tʰe] *us* *hərami* *ne mud̄ʒʰ-pe mukadma tʰonk*
 PST.3.PL that.OBL bastard.OBL ERG I.OBL-on court.case hammer.in
rekʰa *he*
 keep.PFV.M.SG PRS.3.SG

'The man (that bastard!) who you were talking with so nicely is suing me.'

Lit.: 'Which man you were talking with so nicely, that bastard is suing me.'

(from Potts et al. 2009, p. 363)

[HINDI]

In other cases, such as (23), if the NP complements differ, the construction is infelicitous.

- (23) * [_{CorrelCP} *d̄ʒɪs* *admi* *se tum bəhət pjar se bat kər rəhe*
 which man.M.SG with you much love with talk do PROG.M.PL
tʰe] *us* *t̄ɪf̄ar* *ne mud̄ʒʰ-pe mukadma tʰonk*
 PST.3.PL that.OBL teacher.OBL ERG I.OBL-on court.case hammer.in
rekʰa *he*
 keep.PFV.M.SG PRS.3.SG

'The man (a teacher) who you were talking with so nicely is suing me.'

Lit.: 'Which man you were talking with so nicely, that teacher is suing me.'

(from Potts et al. 2009, p. 363)

[HINDI]

In my own fieldwork, I found that the NP_{MC} does not have to be an expressive, nor is it restrict to epithets. Example (24) shows that the and the NP_{MC}, both underlined, may be a different noun entirely as long as both nouns refer to the same semantic entity.

- (24) [*d̄ʒis* *ad^hijapək* *ne* *us-ki* *klas*
 which.SG.OBL teacher.F.SG ERG that.OBL-of.F.SG class.F.SG.OBL
ko *īʃaklet* *di*] *vo* *ɔrət* *səb se* *ət̄ʃ^h:i*
 ACC candy.F give.PFV.F that woman.F.SG all SRC good.F.SG
ad^hiyapək *he*
 teacher.F.SG be.PRS.3.SG

'Which teacher gave her class candy, that woman is the best teacher.'

[HINDI]

(24) is an example from Hindi; the equivalent construction was grammatical in Marwari, as well. Though this has not been tested, the analysis which I present in this chapter predicts that similar examples will also be possible in other MIA languages.

- (25) [*d̄ʒm̄* *minək* *ũ* *sita apre* *frid̄ʒ*
 which.S.OBL man.M.SG.OBL from Sita own.M.SG refrigerator.M.SG
k^haridiyo] *vo* *dukan-va|o* *gəŋo* *hosiyar* *ʔe*
 buy.PFV.M.SG that storekeeper.M.SG very.M.SG smart be.PRS.3.SG

'Which man Sita bought her refrigerator from, that storekeeper is very smart.'

[KM MAR.]

The NP_{Cor} and NP_{MC} may also have their own modifying adjectives (examples 26a⁹ and 26b¹⁰), indicating that they are independently constructed noun phrases.

- (26) a. [*d̄ʒo* *zordar* *ɔrət* *bəhət parefan* *karti*
 which forceful woman.F.SG much trouble.M.SG do.IMPFV.F.SG
he] *vo* *moti* *ləmbi* *ɔrət* *meri*
 PRS.3.SG that large.F.SG tall.F.SG woman.F.SG 1S.POSS.F.SG
sas *he*
 mother-in-law.F.SG be.PRS.3.SG

9. Some speakers did not accept *zordar* as a modifier and prefer *unt̄ʃ^ha swar vali ɔrət* which does not translate directly to English but which means roughly 'loud-speaking-one woman'.

10. While the Marwari noun *moʃi* is glossed as 'large woman', *moʃi* is a noun and not an adjective phrase including an adjective and an NP. This may be most precisely translated as 'large female one' or, less polite, 'fatty'.

'Which forceful woman is causing a lot of trouble, that large tall woman is my mother-in-law.' [HINDI]

- b. [*ḍʒɪki* *moti* *mə-ne* *gəŋi*
 which.F.SG large.woman.F.SG 1S.OBL-ACC a.lot.F.SG
təŋ *kare*] *va* *ḍʒordar*
 harassment.F.SG do.PRS.IMPV.3.SG that forceful.F.SG
lugaʒ *mari* *hasu* *hɛ*
 woman.F.SG my.F.SG mother-in-law.F.SG be.PRS.3.SG

'Which large woman is harassing me, that forceful woman is my mother-in-law.' [MARWARI]

While there are semantic restrictions on how much the two NP complements can differ, it is clear that the NP complement of the relative phrase and the NP complement of the demonstrative do not have to be the same. These examples cannot be analyzed as copies of one another or multiple instantiations of the same nominal head, and some alternative analysis is needed.

2.2.2.4 The Demonstrative Requirement

One of the defining features of the correlative is the necessity of a corresponding correlate in the main clause. Cross-linguistically, the *correlate* may either be a demonstrative or a pronoun, i.e., an indexical. The correlate marks the relativized noun, what de Vries (2005) calls the *pivot* noun, or noun in the main clause which is the linking point between the two clauses.

The demonstrative correlate in Hindi is required and cannot be deleted, as illustrated in (27), where *ve* 'that.PL' is not optional.

- (27) [*ḍʒo* *ləʒkijã* *kʰəʀi* *hẽ*] *(*ve*) *do* (*ləʒkijã*)
 which girl.F.PL standing.F.PL be.PRS.3.PL those two girls.F.PL
ləmbi *hẽ*
 tall.F.PL be.PRS.3.PL

'Which girls are standing, *(those) two girls are tall.' (*from* Dayal 1996, p. 160) [HINDI]

Dayal (1996) calls this non-optionalness of the demonstrative correlate in Hindi may be called the *demonstrative requirement*.

(28) *The Demonstrative Requirement (Preliminary)*

The correlate (phrase) in the main clause, at the modified NP, must include an overt demonstrative (adapted from Dayal 1996).

The demonstrative requirement holds across MIA, including Marwari. As (29) illustrates, the correlative *d̄zəko tʃʰori ubi hε* ‘which girl is standing’ can only occur when the main clause includes the demonstrative *ba* ‘that.FEM’.

- (29) [*d̄zəko tʃʰori ubi hε*] *(*ba*) *tʃʰori*
 which girl.F.PL standing.F.PL be.PRS.3.PL that.F.SG girl.F.SG
dig:i hε
 tall.F.SG be.PRS.3.SG

‘Which girl is standing, (s)he is tall.’ [MARWARI]

Hindi and Marwari do not have third person pronouns but only have what have been called demonstrative pronouns, which are really bare demonstratives and not actually pronouns. Hindi demonstratives are only marked for number, but Marwari demonstratives are marked for number and gender or noun class. For more information on Marwari demonstratives and pronominals, see Appendix A.

Some languages may allow the option of either a pronominal or a demonstrative correlate. For example, in Bangla the correlate may either be a pronoun (30a) or demonstrative (30b), with a strong preference for the pronominal correlate (see Bagchi (1994) for a discussion of the pragmatic restrictions on the correlate in Bangla).

- (30) a. [*baRi-te je mee-Ti kaj kOre*]
 house-LOC which girl-CL work do.PRS.3.SG
tar *bhiSon Osukh*
 PRON.3.SG terrible illness

‘Which girl works at my/our house, she is terribly sick.’ [BANGLA]
 (from Bagchi 1994, p. 23)

- b. [*baRi-te je mee-Ti kaj kOre*]
 house-LOC which.REL girl-CL work do.PRS.3.SG
or *bhiSon Osukh*
 that terrible illness

'Which girl works at my/our house, that is terribly sick.'

(from Bagchi 1994, p. 23)

[BANGLA]

Both (30a) and (30b) are interpreted as 'The girl who works at my house is terribly sick'.

Bangla correlative constructions are subject to the demonstrative requirement as well. Whether the correlate is a pronoun or demonstrative, it is not optional.

(31) [*je Sob chatri-ra notun eSeche*]

which.REL all student-PL new come.PFV.PRS.3

*(*Sei*) *kOek-jon beS buddhimoti*

DEM few-CL quite intelligent

'Few of the girls who came are intelligent.'

Lit.: 'Which girls have come, few of them are intelligent.' (from

Ishani Guha, p.c.)

[BANGLA]

It is not enough for the correlate to be definite. A sentence like (32) in which the correlative corresponds to a proper name in the main clause is not acceptable.

(32) * [*CorrelCP d̄ʒo kʰəɽi he*] *ənu ləmbi he*

which standing.F.SG be.PRS.3.SG Anu tall.F.SG be.PRS.3.SG

Intended: 'Which girl is standing, Anu is tall.'

[HINDI]

This is an indication that it is the indexicality of the correlate which licenses the correlative construction and not definiteness.

While I have stated that all correlate clauses require a correlate in the main clause, it should be noted that there is a small class of sentences in which the correlate seems to be optional. As illustrated in example (33), the correlative clause *d̄ʒo pʰəl kʰəʈ:a tʰa* 'which fruit was sour' does not have a corresponding demonstrative correlate in the main clause.

(33) [*d̄ʒo pʰəl kʰəʈ:a tʰa*] *ramef ne (vo) kʰa*

which fruit.M sour.M.SG be.PST.M.SG Ramesh ERG that eat

lija

take.LGT.PFV.M.SG

'Ramesh ate the fruit which was sour.'

Lit.: 'Which fruit was sour, Ramesh ate.' (*from* Bhatt 1997, p. 56) [HINDI]

This type of construction is only possible where the correlative is acting as a non-case-marked subject or object. Where the demonstrative or correlative would normally be case marked, this type of example is not possible.

There are two possible analyses for this type of construction. Dayal (p.c.) suggests that this may be an example of *pro*-drop, and the demonstrative has been deleted after licensing the correlative clause.

Bhatt (1997) argues that cases where the demonstrative seems to have been dropped are actually cases of a free relative base generated in argument position. They are therefore not correlative constructions at all. While I will follow Bhatt in concluding that what appear to be correlative constructions without a correlate are cases of free relatives entering the syntax directly, it does not affect the analysis presented here. Either the correlative is licensed by a demonstrative which undergoes *pro*-drop and the relationship between the demonstrative and the correlative clause still holds, or these are examples of free relatives and a different construction from the correlative.

There is a class of apparent exceptions to the demonstrative requirement. These are the universals *səb* 'all' and *donō/tinō* 'both/all three', and the single determiner *hər ek* 'each/every one'. If the correlative relates to a DP in the main clause which includes either a universal quantifier or the single determiner, the correlative construction does not seem to be subject to the demonstrative requirement. As (34) illustrates, the correlative *d̄ʒo ləɾkijā kʰəɾi hẽ* is acceptable even when the main clause does not include a demonstrative correlate as long as it relates to one of the universal quantifiers.

- (34) [CorrelCP *d̄ʒo ləɾkijā kʰəɾi hẽ*] *səb/donō/tinō*
 which girl.F.PL standing.F.PL be.PRS.3.PL all/both/all-three

 lambi hẽ
 tall.F.PL PRS.F.PL

'Which girls are standing, all/both/all three are tall.' (*from*

Dayal 1996, p. 162)

[HINDI]

Bhatt (2003, p. 163, footnote 8) suggests that a correlative clause can form a constituent with either demonstrative phrases or phrases headed by these

universals, but ‘[i]t still remains to explain why Correlative clauses can form a constituent with *səb/donō* ‘all/both’ but not with *do/kutʃʰ* ‘two/some.’

Because the universals could also be found with an overt demonstrative, Dayal (1996) suggests that perhaps these include a null demonstrative. I, too, assume that this is the case.

Dayal further suggests that *hər ek* ‘every, each one’ includes a covert partitive construction, *un mē se* ‘from in them’, which may be covert if sufficiently licensed by the pragmatics. This seems to be the case as my Marwari informants consistently corrected Marwari constructions equivalent to the Hindi sentence in (35) to include the overt partitive.

- (35) [*ḍʒo ləʀke kʰaʀe hẽ*] (*un mē se*)
 which boy.M.PL standing.M.PL be.PRS.3.PL those.OBL in from
hər ek mera tʃʰatr he
 each one my student.M.SG PRS

‘Which boys are standing, each one of those is my student.’ [HINDI]
 (from Dayal 1996, p. 162)

In conclusion, the *demonstrative requirement* reflects the fact that Hindi requires a demonstrative or demonstrative phrase to mark the associated argument in the main clause. Other languages allow the correlate to be pronominal or may even allow some optionality between a pronoun and a demonstrative, as is seen in Bangla. The demonstrative requirement might therefore be more accurately called the *demonstrative-pronoun requirement* or the *appropriate correlate requirement*. But, because many readers are already familiar with the demonstrative requirement, I continue to refer to the demonstrative requirement with the stipulation that the requirement may be fulfilled by any appropriate demonstrative or pronominal correlate.

(36) *Revised Demonstrative Requirement*

A correlative clause must be associated with an appropriate correlate in the main clause, where that correlate may be a demonstrative phrase, pronominal, or other indexical.

2.2.2.5 The multi-headed correlative construction

The correlative strategy licenses a very specialized relative construction, the multi-headed correlative (MHC); the MHC has also been called the multi-

head Correlative (Bhatt 2003) or multiple-*wh* correlative (Dayal 1996)). This correlation is so strong that de Vries (2005) concludes that it is a universal that languages which have a single headed correlative construction will have a multi-headed correlative construction, as well. In the multiple headed correlative construction, each relative pronoun or *wh*_{RC} is associated with a corresponding demonstrative in the matrix clause (Bhatt 2003; Dayal 1996).

Below are examples of multiple headed correlative constructions in Hindi and Marwari. Each of the relative pronouns is associated with a demonstrative in the main clause. This association is indicated by subscripts. The subscripts here are merely to make the relationship between the relative phrase and the demonstrative phrase clear without assuming any semantic analysis of indices at this point.

- (37) [MHC [$\widehat{d}\bar{z}is$ $l\bar{a}rki$ ne]₁ [$\widehat{d}\bar{z}is$ $l\bar{a}rke$ $ke\ sat^h$]₂
 which girl.F.SG.OBL ERG which boy.M.SG.OBL with
 k^hela] vo_1 $us-se_2$ $\widehat{d}\bar{z}it$ $gaji$
 play.PFV.M.SG that that.OBL-with win go.LIGHT.PFV.F.SG

'Each girl who played against a boy defeated that boy.'

Lit.: 'Which girl₁ played which boy₂, (s)he₁ defeated her/him₂.'

(from Dayal 1996, p. 197)

[HINDI]

- (38) [MHC [$\widehat{d}ziki$ \widehat{t}^hori]₁ [$\widehat{d}z\acute{a}k\acute{e}$ $\widehat{t}^h\acute{o}ra$ (re) $sat^h\acute{e}$]₂
which girl.F.SG.OBL which boy.M.SG.OBL with
r\acute{a}mi] va_1 $u\eta\acute{a}-\acute{u}_2$ $\widehat{d}z\acute{i}t$ $g\acute{a}ji$
play.PFV.F.SG that.F.SG that.OBL-ACC win go.LGT.PFV.F.SG

'Each girl who played against a boy defeated that boy.'

Lit.: 'Which girl₁ played which boy₂, that₁ defeated that₂.' [KM MAR.]

As we might expect, in Bangla the multi-headed relative clause may be associated with either demonstrative or pronominal correlates as shown in (39a) and (39b), respectively.

- (39) a. [*je meye-Ti je chele-Ti-ke bhalobaSe*]
which girl-CLA which boy-CLA-ACC loves
Se *take* *biye korbe*
 3.PRON 3.PRON.ACC marriage do.FUT.3.SG

'The girl who loves a boy will marry him.'

Lit.: 'Which girl loves which boy, she will marry him.' (*from*

Ishani Guha, p.c.) [BANGLA]

- b. [*je chele- Ti- r theke Se je upohar-Ti*
which boy-CLA-GEN from 3.PRON which gift-CLA got every-CLA
*peyeche] $proti-Ti$ $mey-i$ *Sei* *chele-Ti-ke Sei**
girl-EMPH DEM boy-CLA-ACC DEM gift-CLA-GEN for
upohar-Ti-r jonna dhonnobaad dilo
thanks gave

'Every girl who got a gift from a boy thanked him for that gift.'

Lit.: 'Every girl got which gift from which boy, she thanks him for

that gift.' (*from* Ishani Guha, p.c.) [BANGLA]

The relationship between the single headed correlative (SHC), discussed in the rest of this chapter, and the MHC construction is not straightforward. Dayal (1996) concludes that the SHC and the MHC are both adjoined at IP and are therefore underlyingly the same construction. Bhatt (2003, see Section 2.2.2) takes a different approach. He presents syntactic evidence which shows that the SHC correlative occurs immediately preceding the correlate in the base word order and is base-generated within the same constituent as the

demonstrative. Because the MHC relates to two or more demonstratives and therefore cannot be base-generated as part of a single DemP constituent, he assumes that the SHC and the MHC are necessarily distinct constructions.

In Chapter 3, I summarize Bhatt’s arguments showing that the SHC is base-generated adjacent to the DemP correlate. I also give further evidence that the SHC must enter the syntax as part of the demonstrative phrase.

While I follow Bhatt in assuming that the SHC is base-generated within the same constituent as the correlate, the SHC and the MHC constructions are too similar and closely to consider them distinct constructions. In Chapter 6, I show that it is the availability of the SHC – or more specifically, the grammatical features which allow for the SHC – which allows for the MHC construction. I also present a semantic analysis of the MHC construction and show how the MHC is able to relate to both of the demonstrative correlates in the main clause.

2.3 Previous analyses of the correlative

There are two main approaches to the various relative clause constructions, namely the postnominal relative clause and the correlative construction. These are sometimes called the *uniformity* and the *non-uniformity* accounts.

Much earlier work treated correlative constructions such as (40) as a variation of the postnominal relative clause (41), with different accounts for how the correlative had been fronted away from the NP. This includes Kachru (1973, 1978), Subbarao (1984), and Wali (1982), among others.

(40) [$\widehat{d}3o$ *lʌɾki* *kʰeɾi* *hɛ*] *vo* *lʌmbi* *hɛ*
 which girl.F.SG standing.F.SG be.PRS.3.SG that tall.F.SG be.PRS.3.SG
 ‘Which girl is standing, that/she is tall’ [HINDI]

(41) $\emptyset/ek/vo$ *lʌɾki* [$\widehat{d}3o$ (**lʌɾki*) *kʰeɾi* *hɛ*]
 a/one/that girl.F.SG which girl.F.SG standing.F.SG be.PRS.3.SG
lʌmbi *hɛ*
 tall.F.SG be.PRS.3.SG
 ‘A/one/that girl who is standing is tall.’ [HINDI]

The non-uniformity approach, exemplified by Dayal's work in Srivastav (1991) and Dayal (1996), argues that the postnominal relative clause and correlative clause are underlyingly distinct constructions. Dayal outlines several structural and syntactic distinctions between the two relativizing structures. These distinctions, for the most part outlined in Section 2.2.2.1 above, are assumed by most recent work relating to correlatives. Most recent work, building on Srivastav (1991), Dayal (1996), and Grosu and Landman (1998), take a non-uniformity approach (de Vries 2001, 2005; Bianchi 2002a,b; Bhatt 2003; Bhatt and Lipták 2009; Lipták 2009), treating the correlative construction (40) as distinct from the postnominal relative construction (41).

Some authors continue to take a uniformity approach, treating both correlatives and postnominal relative clauses as underlyingly the same construction. Mahajan (2000), for instance, argues for a uniformity account, and Kachru (2006)'s Hindi grammar assumes a uniform analysis based on his analysis in Kachru (1973). Uniformity accounts maintain that all relative clause word orders originate at the postnominal relative position, either giving an alternative analysis to the distinctive features of the correlative pointed out by Dayal (1996) or, in some cases, not addressing them at all. Mahajan (2000), for example, includes only examples which include demonstratives and does not address the question of why correlatives are subject to the demonstrative requirement but postnominal and extraposed relative clauses are not.

Dayal (in Srivastav 1991 and Dayal 1996) was one of the first to show that the correlatives in Hindi, and by extension other MIA languages, are a distinct construction from the postnominal relative clause, which follows the noun. Others (Downing 1973; Keenan 1985; Andrews 1985) had noted that there were differences, but Dayal was instrumental in defining the features of the correlative that distinguish it from other relativization structures.

Dayal argues that the features outlined in Section 2.2.2 show that the correlative and postnominal relative must be syntactically distinct constructions. Summarizing briefly, the correlative licenses multi-headed relative clauses, may be internally headed, and they require a demonstrative correlate in the main clause. The postnominal relative, on the other hand, does not require a correlate, is prohibited from being internally headed, and has different binding restrictions from the correlative construction.

Dayal also showed that the semantic contribution of correlatives is distinct from the postnominal relative clause. Grosu and Landman (1998) build on

this discussion and propose that relativizing constructions such as correlatives, free relatives, internally headed relative clauses, and what they call degree relatives are interpreted differently than postnominal relative clauses, which act as restrictive modifiers. The semantic contribution of the correlative clause will be discussed in more depth in Chapter 6.

Further, none of the uniformity accounts can account for examples presented by Bhatt (2003), such as (13) in Section 2.2.2.1, in which the correlative is pronounced within the main clause preceding the demonstrative phrase. These analyses also fail to predict constructions like the dual headed examples shown in Section 2.2.2.2.

2.3.1 The correlative as a quantifier adjoined to IP

Having established that the correlative is not underlyingly a postnominal relative clause, Dayal (1996) argues that the correlative clause is base generated at the left periphery. She proposes that a sentence like (42) has the syntactic structure (43) (Dayal 1996, p. 168). The correlative is merged directly at IP and has not undergone movement. The indexation in (42) indicates that the correlative clause is associated with the demonstrative phrase, but it is not intended to mean that any movement has taken place.

- (42) [CP [RelIP $\widehat{d}3o$ $l\grave{a}rki$]_j t_j $k^h\grave{a}r\acute{i}$ $h\epsilon$]_i vo_i $l\grave{a}rki$
 which girl.F.SG standing be.PRS.3.SG that girl.F.SG
 $l\grave{a}mbi$ $h\epsilon$
 tall.F.SG be.PRS.3.SG

'Which girl is standing, that girl is tall.'

[HINDI]

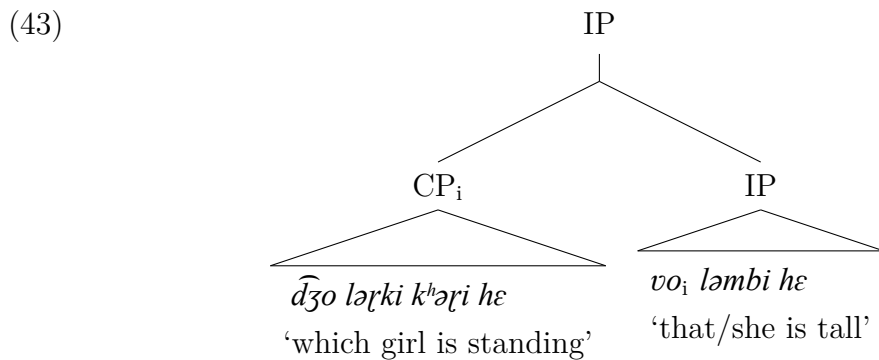

Semantically, Dayal analyzes the correlative clause as a generalized, universal quantifier which binds a variable in the main clause, namely the demonstrative. The correlative CP itself is adjoined at IP, in the same position as the one in which other quantifier phrases which have undergone quantifier raising (QR) at LF are interpreted. As a quantifier, the correlative differs from other quantifier phrases in that ‘its first argument is the intersection of two sets rather than one basic set’ (Dayal 1996, p. 191). The statement $\widehat{d}\text{ʒo } l\text{ə}rki\ k^h\text{ə}r\text{i}$ $h\text{e}, vo\ l\text{ə}rki\ l\text{ə}mbi\ h\text{e}$ ‘which girl is standing, that girl is tall’ would accordingly have the structure (44).

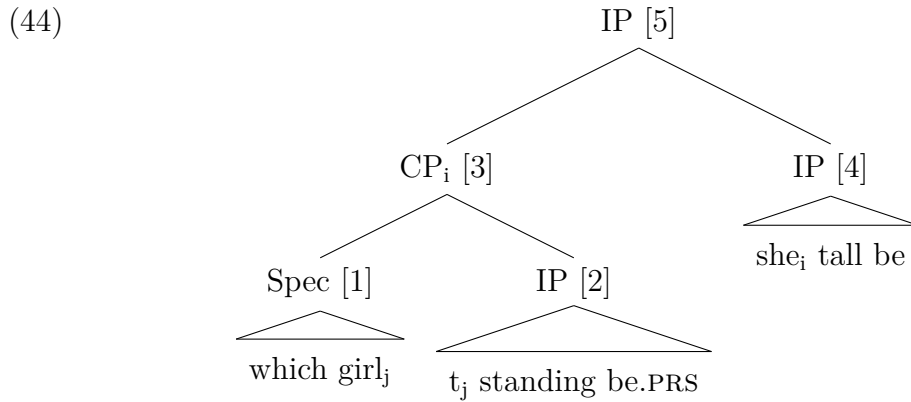

In Dayal’s notation, all of the indices are the same to reflect the fact that all of the relevant phrases refer to the same girl. For clarity, I have distinguished between them such that the index j indicates that the relative phrase has been *wh*-raised from the position of the trace t_j , whereas the index i indicates a quantifier-variable relationship, without movement, between the correlative CP and the demonstrative.

Because the correlative is analyzed as a quantifier phrase (QP), IP has the constituent structure [QP_{*i*} IP]. Dayal assumes that structures of the form [QP_{*i*} IP] are translated as [Quantifier_{*i*} λx_i IP’]. This is reminiscent of Heim and Kratzer’s system for QR and Predicate Abstraction except that the quantifier has not been raised but adjoins to IP through external merge and is interpreted within the main clause through coindexation with a demonstrative variable rather than leaving behind a trace.

The derivation of (44) is as follows. The relative pronoun or wh_{RC} does not make any semantic contribution. The denotation of the relative phrase $\widehat{d}\text{ʒo } l\text{ə}rki$ ‘which girl’ is therefore the same as the NP, as shown in (45).

(45) [1] $\lambda x.x$ is a girl¹¹

While the wh_{RC} does not make any semantic contribution, Dayal posits a wh -operator which marks C with a $+wh$ feature and which carries the definiteness operator (σ), reflecting the fact that the correlative clause must pick out a unique or definite individual. Following Link (1983), plural correlative clauses, then, relate to ‘sum’ individuals rather than singular atomic individuals. More specifically, σx is the unique plural individual x , where x may be made up of multiple atomic individuals.

$$(46) \quad [2] \lambda V.\lambda P.P[(\sigma x.x \text{ is standing} \wedge V(x))]$$

Under this analysis, the correlative contributes a set of properties P where P is a property of a unique or definite individual which both satisfies the property defined by the NP and property defined by the predicate of the correlative clause (Dayal 1996, p. 190). The correlative, therefore, has the meaning in (47).

$$(47) \quad [3] \lambda P.P(\sigma x_j(x_j \text{ is a girl} \wedge x_j \text{ is standing}))$$

Because of the demonstrative variable in the main clause the main clause IP also denotes a set of properties – in this case, the property of being a standing girl. The correlative CP and the IP of the main clause then combine through predicate abstraction to yield the unique individual x where x is defined by the property contributed by the correlative and the property contributed by the main clause.

$$(48) \quad [4] \lambda x.x_i \text{ is tall}$$

$$[5] (\sigma x.x_i \text{ is a girl} \wedge x_i \text{ is standing}) \text{ is tall}$$

There are ways in which the interpretation of the relationship between the correlative and the associated demonstrative is something like a quantifier-variable relationship. There is a sense in which the correlative is somehow interpreted at the demonstrative phrase such that the individual described by the correlative is restricted by the property contributed by NP component of DemP. There are problems with this approach, though. First, despite their similarities, the relationship between the correlative clause and the demonstrative in the main clause is not the same as the relationship between an operator and a variable. When a demonstrative or variable is bound, it is generally the

11. I have adapted Dayal’s lexical entry for NPs slightly in order to be consistent with the notation I have used elsewhere

demonstrative itself which requires that there be something to bind it. That is, the main clause of a correlative construction is acceptable without the addition of the correlative. It is the correlative clause which requires a corresponding demonstrative in order to be able to enter the syntax. If the correlative were an operator, the demonstrative requirement could be reworded to state that the correlative clause itself requires something to bind. Nowhere else do we find this kind of relationship where it is the binder which requires something be bound by it. Even in cases of movement and the binding of a trace, it is the trace (or the variable on the trace) which requires a binding relationship in order for it to be interpreted. The moved element itself does not require that it have something to bind, as can be seen in cases where a trace may be deleted. Dayal's analysis, therefore, leaves open the question: Why is the demonstrative requirement so essential to the correlative construction?

A second problem with Dayal's approach to the correlative construction assumes that the correlative contributes the properties of a definite individual. Even though the correlative is assumed to be a quantifier, there is nothing in its semantic contribution which restricts CorrelCP from relating to a definite, non-indexical DP in the main clause. Yet, as Dayal shows in examples like (32), definiteness is not sufficient for licensing the correlative construction. (See the discussion in Section 2.2.2.3). That a correlative must relate to an indexical must therefore be stipulated and does not follow naturally from the components of the construction itself or how they combine.

Further, in Section 2.3.2, I discuss examples presented by Bhatt (2003) which show that the correlative and the demonstrative is not a relationship of variable binding, as shown by the behavior of variable binding with respect to islands.

2.3.2 The correlative is base-generated at the DemP

Section 2.2.2.1 questioned whether the correlative clause must always occur at the left periphery. As (13) shows, it is possible for the correlative to be pronounced inside of the main clause, preceding the demonstrative phrase. Bhatt (2003) argues that this largely overlooked word order, in which the correlative is adjacent to the demonstrative phrase, is not just possible but is where all correlatives are base generated. A correlative construction such as (49) would then have the indicated constituent structure.

- (49) *ram* [[_{CorrelCP} *ḍʒo sidi sel pər hε*]¹² [_{DemP} *us*
 Raam which CD sale on be.PRS.3.SG that.OBL
sidi ko]] *kʰaridega*
 CD ACC buy.FUT.3MS

'Raam will buy the CD which is on sale.'

Lit.: 'Raam will buy which CD is on sale, that CD.' (adapted from
 Bhatt 2003, p. 495)

[HINDI]

Bhatt (2003) proposes that the correlative construction has the following structure, in which the correlative CP and the DemP are base generated as part of the same constituent. More specifically, the correlative CP is adjoined to the demonstrative phrase Dem-XP. Bhatt uses the indices to indicate that both the Dem-XP and CorrelativeCP refer to the same individual.

- (50) a. [[RC] [_{DemP} Dem NP]]

b.

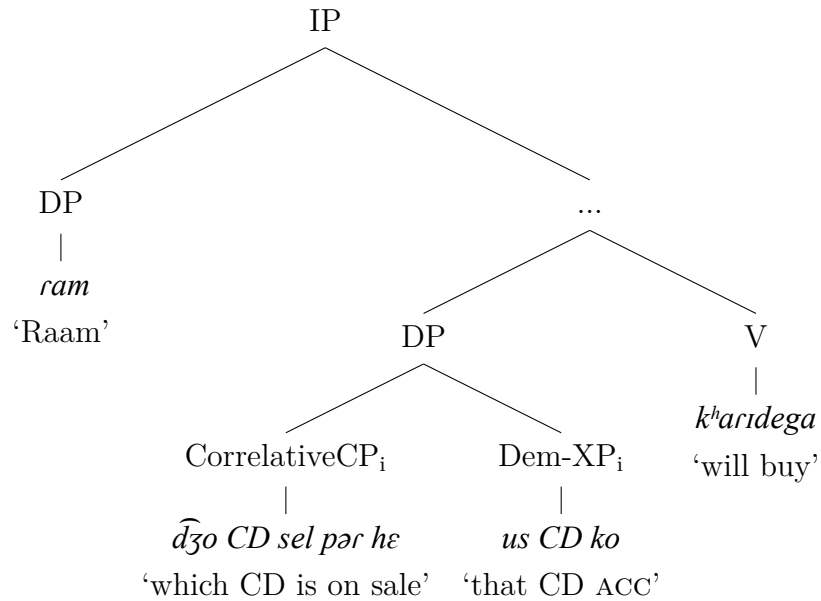

Bhatt offers several arguments that the correlative is base generated at DemP which I will summarize here. First, he argues that the syntactic features of the correlative construction show that the correlative cannot be base generated at the IP itself but can only be base generated at the demonstrative phrase. Only then may the correlative be fronted. The fact that the correlative is subject to island effects is evidence, as well, that the correlative-correlate relationship is not that of variable binding.

12. The consultants who I worked with preferred *ḍʒo sel me hε*, literally 'which are in sale'.

Second, Bhatt argues that the correlative and DemP are both base-generated as part of the same constituent, showing that the correlative is subject to the Coordinate Structure Constraint and that reconstruction effects show that the correlative must be interpreted at the demonstrative phrase.

Below, I outline Bhatt's arguments in more detail.

Under Dayal's analysis, correlatives are base generated at the IP without undergoing any movement. We can see that this is not the case through island effects (Bhatt 2003). Finite clauses are not islands for overt movement in Hindi, as (51) illustrates.

- (51) *raam_i sita d̄ʒanti* *he* [*ki pud̄ʒa ko t_i*
 Raam Sita know.IMPFV.F.SG PRS.3.SG COMPL Pooja DAT
pəsənd he]
 liking be.PRS.3.SG

'Raam_i, Sita knows that Pooja likes t_i.' (*adapted from Bhatt 2003, p. 503*)

[HINDI]

Similarly, a fronted correlative may appear even when the associated demonstrative is inside of a finite clause (52).

- (52) [CorrelCP *d̄ʒo ləʀki tivi pər ga rəhi he*]_i
 which girl.F.SG TV.OBL.F on sing PROG.F.SG PRS.3.SG
sita soʃ^hti *he ki* [*t_i vo*] *səndər he*
 Sita think.IMPFV.F.SG PRS COMP that beautiful be.PRS.F.SG

'Sita thinks that the girl who is singing on TV is beautiful.'

Lit.: 'Which girl is singing on TV, Sita thinks that that/she is beautiful.'

(*from Bhatt 2003:500*)

[HINDI]

As expected, the correlative can be separated from the associated demonstrative by (theoretically) any number of finite clauses (Bhatt 2003). But, while Hindi does allow overt movement out of a finite clause, overt movement out of a relative clause island is prohibited

- (53) * [*arund^hati*]_i *ne mud^hz̄^h-ko* [*vo kəhani d̄z̄o t_i*
 Arundhati ERG I.OBL-DAT that story.F.SG which
l^khi] *pəsənd hε*
 write.PFV.F.SG liking be.PRS.3.SG

Intended: 'Arundhati, I like that story which she wrote.' (from
 Bhatt 2003, p. 503)

[HINDI]

In the same way, the correlative clause cannot be separate from the correlate phrase by an island.

- (54) * [*d̄z̄o vahā rəhta hε*]_i *mud^hz̄^h-ko*
 which there stay.IMPV.M.SG PRS.3.SG I.OBL-DAT
 [*vo kəhani* [*d̄z̄o arund^hati ne* [*t_i us-ke bare mē*]
 that story.F.SG which Arundhati ERG that.OBL-about
l^khi]] *pəsənd hε*
 write.PFV.F.SG liking be.PRS.3.SG

Intended: 'Who lives there, I like the story that Arundhati wrote about
 him.' (from Dayal 1996, p. 183)

[HINDI]

The fact that correlatives cannot appear at the left periphery when the demonstrative is inside of an island is evidence that the correlative is not base generated at IP but has undergone movement. Bhatt points out that island effects are triggered by movement. Because correlatives display sensitivity to island effects, a fronted correlative must have undergone movement. The demonstrative phrase has not undergone any overt movement, so it must be the correlative which has moved and is thereby triggering the island effects that we see in these examples.

Bhatt (2003) also presents evidence that the relationship between the correlative and the correlate cannot be that of variable binding, as Dayal (1996) suggests. Like English, variable binding in Hindi does not display island effects. As (55a) shows for English, it is possible for a quantifier phrase to bind into a relative clause island. The same kind of binding into an island is possible for Hindi, as well, as seen in (55b).

- (55) a. Every boy_i likes [the story [that Arundhati wrote about him_i]].

- b. *hər lərke_i ko* [_{DP} *vo kəhani*
 each boy.OBL.M.SG DAT that story
 [_{RC} *d̪ʒo arundh̄ati ne us_i-ke bare m̄ẽ lik^{hi}*]]
 which_{RC} Arundhati ERG that-about write.PFV.F.SG
pəsənd h̄e
 liking be.PRS.3.SG

'Each boy_i likes the story which Arundhati wrote about him_i.'

(from Bhatt 2003, p. 500)

[HINDI]

If the correlative-demonstrative relationship were that of variable binding, (54) should be acceptable, but this is not the case. From this, Bhatt (2003, p. 501) concludes that 'The ungrammaticality of [(54)] shows that the relationship between the Correlative clause and the Demonstrative cannot just be variable binding'. If the relationship between them is not that of operator-variable, then the question of how the correlative is related to the correlate in the main clause remains open.

Not only has a fronted correlative undergone movement away from the demonstrative, as the island effects show, but there is also evidence that the correlative is base-generated as part of the same constituent as the demonstrative. One piece of evidence for this comes from the Coordinate Structure Constraint (CSC, Ross 1967).

(56) *The Coordinate Structure Constraint*

In a coordinate structure, no conjunct may be moved, nor may any element contained in a conjunct be moved out of that conjunct.

It is possible for two demonstrative phrases in Hindi, both of which are associated with a correlative, to be coordinated (Bhatt 2003), as shown in (57).

- (57) *rahul adʒkəl* [ConjP [[CorrelCP *dʒo kitab sera ne*
 Rahul nowadays which book.F.SG Sera ERG
lkʰi he] *vo*] *ɔr* [[CorrelCP *dʒo*
 write.PFV.F.SG PRS.3.SG that CONJ which
kartun fjam ne bənaja] *vo*] *pəɽʰ*
 cartoon/comic.M.SG Shyam ERG made.PFV.M.SG that read
rəha he
 PROG.M.SG PRS

'Nowadays, Rahul is reading the book that Sarah wrote and the comic that Shyam made.'

Lit.: 'Rahul nowadays is reading which book Sarah wrote, that, and which comic Shyam made, that.' (*from* Bhatt 2003, p. 504) [HINDI]

The coordinated constituent may also be moved or fronted just as any other argument might be cited Bhatt2003, as illustrated in (58).

- (58) [ConjP [[CorrelCP *dʒo kitab sera ne lkʰi*
 which book.F.SG Sera ERG write.PFV.F.SG
he] *vo*] *ɔr* [[CorrelCP *dʒo kartun*
 PRS.3.SG that CONJ which cartoon/comic.M.SG
fjam ne bənaja] *vo*]_i *rahul adʒkəl* _{t_i} *pəɽʰ*
 Shyam ERG made.PFV.M.SG that Rahul nowadays read
rəha he
 PROG.M.SG PRS

'Which book Sarah wrote, that, and which comic Shyam made, that, Rahul is reading nowadays.' (*adapted from* Bhatt 2003, p. 504) [HINDI]

The CSC dictates that, where two correlativized NPs are coordinated, movement from within the coordinated structure is blocked. If the relative is base-generated at the IP, this predicts that there is no restriction on the relative being associated with a NP inside of a coordinate structure. The CSC would not restrict a relative clause being base generated at the CP but would restrict a constituent of the DemP from being fronted. If the two [Correl DemP] phrases are truly constituents, then we expect that the CSC would prohibit either of the correlatives from being extracted. That is, in

fact, what happens: neither of the correlatives may be extracted from the correlative phrase (Bhatt 2003, p. 506).

- (59) a. * [CorrelCP $\widehat{d}zo$ *kitab* *sera ne lik^{hi}* *he*]
 which book.F.SG Sera ERG write.PFV.F.SG PRS.3.SG
rahul ad³kəl [ConjP [*t_i vo*] *ɔr* [[CorrelCP $\widehat{d}zo$ *kartun*
 Rahul nowadays that CONJ which comic.M.SG
ʃjam ne bənaja] *vo*]] *pəɽ^h rəha he*
 Shyam ERG made.PFV.M.SG that read PROG.M.SG PRS

Intended: 'Nowadays, Rahul is reading the book that Sarah wrote and the comic that Shyam made.' (from Bhatt 2003, p. 504) [HINDI]

- b. * [CorrelCP $\widehat{d}zo$ *kartun* *ʃjam ne bənaja*]
 which cartoon/comic.M.SG Shyam ERG made.PFV.M.SG
rahul ad³kəl [ConjP [[CorrelCP $\widehat{d}zo$ *kitab sera ne*
 Rahul nowadays which book.F.SG Sera ERG
lik^{hi} he] *vo*] *ɔr* [*t_i vo*]] *pəɽ^h*
 write.PFV.F.SG PRS.3.SG that and that read
rəha he
 PROG.M.SG PRS

Intended: 'Which comic Shyam made, Rahul nowadays is reading which book Sarah wrote, that and that.' (from Bhatt 2003, p. 504) [HINDI]

From this we can conclude that the correlative and the demonstrative are indeed within the same constituent.

As additional evidence, Bhatt shows that the correlative clause reconstructs to the correlative-demonstrative phrase at LF. First, the correlative shows condition C effects: 'if a pronoun c-commands the demonstrative phrase associated with a Correlative clause, then the pronoun cannot corefer with a name contained inside that Correlative clause' (Bhatt 2003, p. 512). That is, if the correlative associated with an object demonstrative base generated at the fronted position, it would have the following structure.

(60)

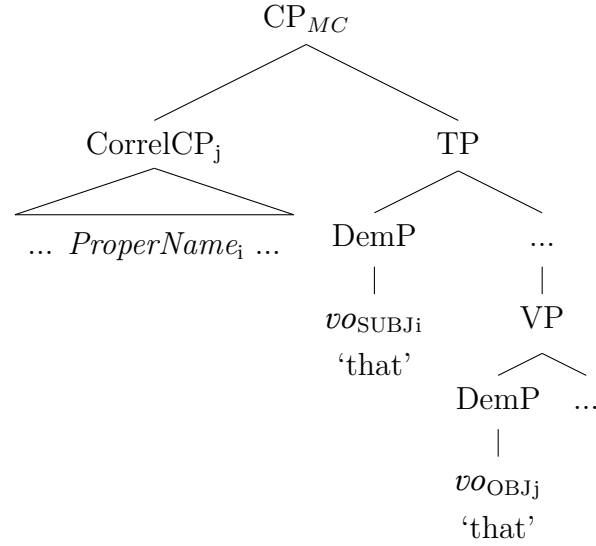

Given this structure, a demonstrative in the subject position should be able to freely corefer with a name inside of the correlative clause where the correlative clause itself is associated with the object DemP (indicated by the indices i and j respectively).

This does not prove to be the case, as we can see in the following example. In this example, the CorrelCP $\widehat{d}zo\ lark\i\ sita_i\ ko\ pjar\ karti\ he$ ‘which girl loves Sita’ is associated with a demonstrative in the object position, as shown by the subscript j . If CorrelCP were base generated at IP, then the proper name *Sita* inside of CorrelCP should be able to bind the subject demonstrative *us* ‘that’. This binding relationship is indicated by the subscript i .

- (61) * [$\widehat{d}zo\ lark\i\ sita_i\ ko\ pjar\ karti\ he$]_j
which girl.F.SG Sita ACC love do.IMPV.F.SG PRS.3.SG
us_i-ne us_j-ko t^hukra dija
that.OBL-ERG that.ERG-ACC rejection.M.SG give.PFV.M.SG

[Which girl loves Sita_i]_j, she_i rejected her_j.’ (from Bhatt 2003, p. 513)

[HINDI]

An approach which assumes that the correlative is adjoined at IP predicts that (61) will be grammatical, but this is not the case. The proper name *Sita* is not allowed to corefer with a subject in the demonstrative position. Therefore, (61) cannot have the expected reading (62).

- (62) Which girl loves Sita, Sita rejected that girl.
Or, roughly: Sita rejected the girl who loves Sita.

Instead, the reading in (62) is unavailable. Bhatt takes this unavailability to be the result of a violation of Condition C.

Bhatt concludes that the correlative construction (64) has the structure (63), where the CorrelCP adjoins above the associated DemP.

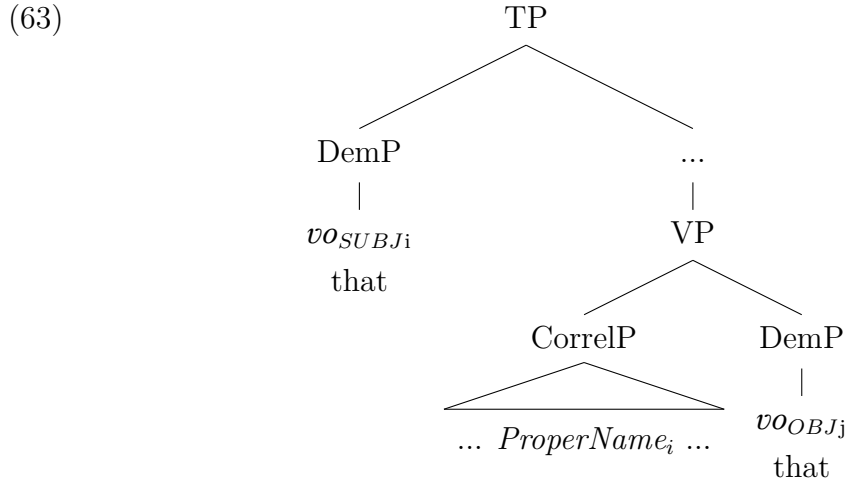

The correlative may then raise to a fronted position but on interpretation is reconstructed to object demonstrative.

On the other hand, if the correlative is base generated at the demonstrative phrase itself, lower than the subject, then it follows that a proper name in the correlative should not be able to corefer with a demonstrative in the subject position of the main clause.

- (64) [*d̄ʒo ləɽki sita_i ko pjar karti he*]_j
 which girl.F.SG Sita ACC love do.IMPV.F.SG PRS.3.SG
us_j-ne us_i-ko tʰukra dija
 that.OBL-ERG that.ERG-ACC rejection.M.SG give.PFV.M.SG
 '[Which girl loves Sita_i]_j, she_i rejected her_j.' (from Bhatt 2003, p. 513)
 [HINDI]

The construction in (64) is felicitous and may have the interpretation (65).

- (65) Which girl loves Sita, that rejected Sita.
 Or, roughly: The girl who loves Sita rejected Sita.

Quantifier binding also shows similar reconstruction effects (Bhatt 2003). Cross-linguistically, a quantifier can only bind a pronoun that it overtly c-commands.

- (66) a. [Every boy]_i loves his_i mother.
 b. *His_i mother loves [every boy]_i.

There is a small class of exceptions to this, and those are the raising verbs. In these cases, we can assume that a raised subject is interpreted at its trace at LF and that, at LF, the pronoun is c-commanded by the embedded subject. In (67), for example, *seems* is a raising verb. The subject of the embedded CP, ‘his father’, is raised to the subject position of the matrix clause where it scopes over the quantifier phrase *every boy*.

- (67) [His_i father]_j seems to every boy_i [t_j to be a genius].

We find a similar pattern in Hindi correlative constructions. Consider example (68). In this example, Bhatt considers the verb *samādāṛh-* ‘understand, consider’ to be acting as a raising control verb. The correlative *dāṛis laṛke ko vo_i pāsānd karti hē* is associated with the subject of the embedded clause, *us* ‘that.OBL’.

- (68) [CorrelCP *dāṛis laṛke ko vo_i pāsānd karti*
 which boy.OBL.M.SG ACC that liking do.IMPV.F.SG
hē]_j *hār laṛki* [t_j [*us laṛke ko*]_j]
 PRS.3.SG each girl.F.SG that.OBL boy.OBL.M.SG DAT
budd^himan samāj^hti hē
 intelligent consider.IMPV.F.SG PRS.3.SG
 ‘[Which boy likes that/her_i]_j, every girl_i considers that boy_j (to be)
 intelligent.’ [HINDI]

Significantly, (68) has a distributive reading in which every girl considers the boy who likes her to be intelligent. This reading is unexpected if the correlative is base-generated at IP, scoping over the quantifier phrase *hār laṛki* ‘every girl.’ As (66a) shows, if the correlative is base-generated higher than the quantifier phrase, these should not be able to corefer. On the other hand, an analysis in which the correlative clause is base generated within the same constituent as the demonstrative, and is raised out of the embedded CP complement of a raising control verb, correctly predicts that (68) is acceptable with the intended reading. This is further evidence that the correlative clause is base-generated within the same constituent as the demonstrative phrase and cannot have been base-generated at IP.

Quantifier binding in sentences like (68) shows that they have an underlying structure like (69).

(69) Each girl considers [[which boy likes her] [that boy]] (to be) intelligent.

Based on the binding effects, island effects, and the patterns seen in variable binding, Bhatt proposes that the correlative CP and the DemP are underlyingly base-generated as part of the same constituent with the following constituent structure in which the correlative is adjoined above the demonstrative phrase. The correlative-demonstrative constituent then has the structure (70).

(70) [[CorrelCP] [Dem NP]]

The correlative itself may then undergo movement to a fronted position but is interpreted at its trace at LF.

2.3.3 Remaining Questions

Bhatt's argument that, based on syntactic evidence, the correlative is merged at the demonstrative phrase is compelling, but it does not explain how the demonstrative licenses the correlative. If the relationship between them is not variable binding, then what is it?

There are still lingering questions about the syntactic relationship between the correlative and the correlate, as well. They seem to be intimately linked, so much so that the presence of the demonstrative licenses the correlative construction, yet none of the analyses so far can account for why this is the case. Bhatt's analysis goes as far as saying that they are within the same constituent, but there are several reasons why we do not want to say that the correlative is a sister to or adjoined to the demonstrative phrase, which is what we are left with in Bhatt's analysis. If they truly are sisters, what motivates this type of merger yet simultaneously prevents it from over-generating?

In the next section, I propose that it is the semantics of the demonstrative itself which is the key to understanding how these structures are constructed.

2.4 Conclusion

In this chapter, I introduced the correlative construction, defining the terminology to be used in this dissertation. Section Section 2.2 outlined many of its

syntactic features as first set out by Dayal (1996). Based on the discussion in Section 2.2.2, we can now summarize the syntactic features of the correlative construction as (71), below.

(71) Syntactic features of the correlative construction (Section 2.2.2):

- There must be an appropriate correlate, either a demonstrative or a pronominal, in the main clause (*the demonstrative requirement*).
- Are base generated to the left of the associated phrase, as part of the same constituent, and may then optionally be fronted .
- Headed by a relative pronoun (wh_{RC}), which may remain in situ.
- The relativized element may appear in both the relative clause and the correlative (*headedness*), and both the wh_{RC} and the correlate may be case marked independently.
- Correlatives license multi-headed relative clauses.

In Section 2.3, I summarized some of the previous approaches to analyzing the correlative construction. These analyses assume that the correlative adjoins to the main clause, either at IP (Dayal 1996) or at the demonstrative phrase itself (Bhatt 2003).

Dayal (1996), proposes that the correlative clause acts as a generalized, universal quantifier which binds a variable in the main clause, namely the demonstrative. Under this account, the correlative would then have the structure (72).



Bhatt (2003) proposes that the correlative, rather than adjoining to IP, adjoins directly to the demonstrative phrase (see Section 2.3.2). The correlative and the demonstrative are therefore base-generated as part of the same constituent. Under Bhatt’s approach, the correlative construction would then have the structure (73), where the correlative adjoins to DemP.

(73)

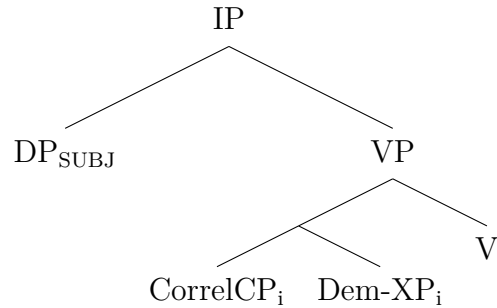

Bhatt (2003) presents several pieces of evidence to support this analysis. First, that a correlative at the left periphery has undergone movement is illustrated through island effects. That operators are able to bind into islands but correlatives cannot is also evidence that the relationship between the correlative and the demonstrative is not an operator-variable relationship.

Binding effects in correlative constructions also support an analysis in which the correlative is base-generated adjacent to the demonstrative correlate. Finally, movement of a correlative out of a coordinated structure is restricted. Thus, the correlative and the demonstrative phrase are part of the same constituent.

Both of these analyses leave open some important questions regarding the correlative construction. The first question is: What is the relationship between the correlative and its correlate? If it is not a quantifier-variable relationship, as Dayal (1996) suggests, then what other relationship would allow for the close semantic and syntax dependency between the correlative clause and its demonstrative?

One of the key features of the correlative construction is the demonstrative requirement: the correlative construction can only occur when there is an appropriate, indexical correlate in the main clause. What is it about the indexical which allows the correlative to enter the syntax?

Chapter 3

The demonstrative nature of the nominal correlative

3.1 The correlative and the demonstrative

There has been a lot of work done on the correlative construction, and a lot is known about both its structure and its semantic contribution. Yet, while one of the most central features of the correlative construction is the necessity of a demonstrative correlate (or pronominal, as the case may be), the relationship between the demonstrative and the correlative clause has remained opaque.

This chapter looks at the nominal correlative construction in which the correlative and its corresponding demonstrative are nominal arguments. Here, I introduce a new analysis of the correlative construction based on the internal structure of the demonstrative. Under this approach, the correlative enters the syntax as the indexical argument of the demonstrative. In later chapters, I show that the same analysis holds for adverbial correlatives, as well.

Following Nunberg (1993), a demonstrative phrase has four syntactic components: the *index* i which carries the deictic information, the demonstrative head which carries the classificatory information such as phi-features and definiteness, a relation R which relates the index to the individual contributed by DemP, and an NP descriptor (Section 3.2). The syntactic structure of DemP (1) includes an indexical projection i (Elbourne 2008), which usually remains covert and unpronounced.

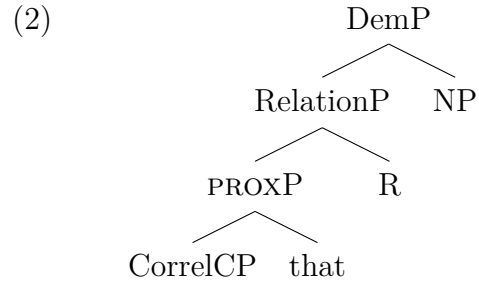
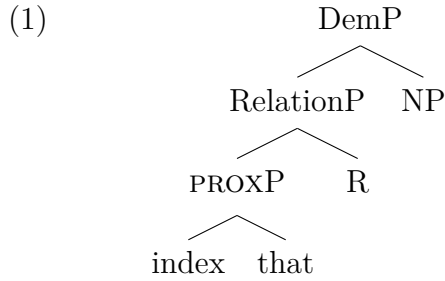

I propose that the correlative clause is an overt pronunciation of the index of the demonstrative (Section 3.3). Thus, rather than adjoining to the demonstrative phrase, the correlative is an argument of the demonstrative head. The semantic relation between the correlative index and the individual contributed by DemP is therefore the same as the relationship between the index and the interpretation of the demonstrative.

This analysis can easily be extended to other indexical correlates such as the pronominal correlate in Bangla (Section 3.3.1). The syntactic structure of the pronoun (3) includes a pronoun morpheme which takes a relation phrase (RelationP) composed of *i* and a relation R as its argument. The correlative-pronoun constituent has the structure (4).

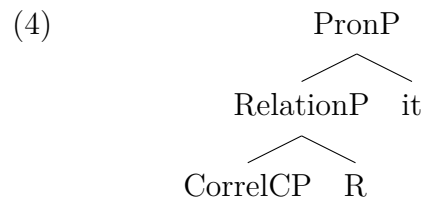
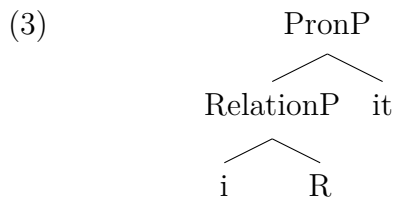

Just as in the correlative-demonstrative constituent, the correlative acts as an overtly pronounced index of the pronoun.

This analysis has several advantages over previous analyses. The first advantage is that, under this analysis, there is a clear relationship between the correlative and its correlate. The correlative can only relate to indexical correlates such as demonstratives and pronominals because enters the syntax as overtly pronounced index, where the index is a projection within the syntax of the demonstrative. For this reason, the correlate cannot be a proper name, definite, or indefinite phrase. The semantic relationship between the correlative and the correlate is clear, as well, and follows directly from the internal structure of the demonstrative. Because CorrelCP is the indexical argument of the correlate, the correlative is interpreted just as an indexical is. While it is not

an operator-variable relationship as Dayal (1996) suggests, the correlative's role in the semantic contribution of the demonstrative gives the correlative construction a similar interpretation.

Another advantage of this approach is that the correlative can only be base-generated within the same constituent as the correlate (see Chapter 2, Section 2.3.2). Because the correlative does not enter the syntax through adjunction, as Dayal (1996) and Bhatt (2003) argue, there is no need to stipulate that it can only adjoin to the demonstrative phrase and is not able to adjoin elsewhere in the clause, such as at TP or CP.

Finally, this analysis makes some predictions about the correlative construction which are borne out (Section 3.4). If the correlative is an overtly pronounced index of the demonstrative, then it follows that other types of indexicals may act as the correlate as well (Section 3.4.1). This is indeed the case; both first person and second person pronouns are also able to act as correlates in Marwari.

3.2 Internal Structure of the Demonstrative

The key to the correlative construction and the relationship between the correlative and the demonstrative lies in the internal structure and composition of the demonstrative itself. In this section, before turning to the correlative construction, I give an account of the syntax and semantic composition of non-relativized demonstratives. I follow Elbourne (2008) in assuming that the index, which is often indicated through a lowercase subscript on the demonstrative and the phrase which it corefers with, is actually a projection within the syntactic structure of the demonstrative.

Nunberg (1993) suggests that indexicals, or expressions which carry an index such as demonstratives and pronouns, are made up of four components: the classificatory component, the relational component, the deictic component which picks out an index, and the interpretation of the indexical within the main clause. The *classificatory component* includes the phi-features (gender, number, person) and animate features (animate, inanimate) of the index. Other features such as geographic anchors, visibility, and tangibility are part of the classificatory information, as well. The *deictic component* identifies the index by gesturing and, in the case of the demonstrative, giving information about proximity.

The *relational component* is the contextually defined relationship between the index and its interpretation (Nunberg 1993). The relationship itself is not defined within the syntax but is dependent on the pragmatic accessibility of the relation. ‘[M]ost of the work of specifying the interpretation is accomplished, rather than by the utterance, in a process mediated by the speaker’s intention, the linguistic context, considerations of relevance and so on’ (p. 17). Nunberg assumes that logical relation is permissible, but admits that some relations are more accessible than others – ‘more salient, more reliable, more generally exploitable’ (p. 30-31).

The interpretation of DemP is the individual which it contributes. Nunberg demonstrates that the individual contributed by the demonstrative is not necessarily the same as the index. He calls this *deferred reference*, in contrast with a *direct reference* interpretation in which both the index and the interpretation are the same. I discuss restrictions on R in more depth in Section 3.5, but what is most important here is that the availability of deferred reference means that both *i* and R are present within the syntactic structure and the semantic composition of the indexical demonstrative.

Elbourne (2008, building on Nunberg 1993) proposes the following internal structure for the demonstrative.

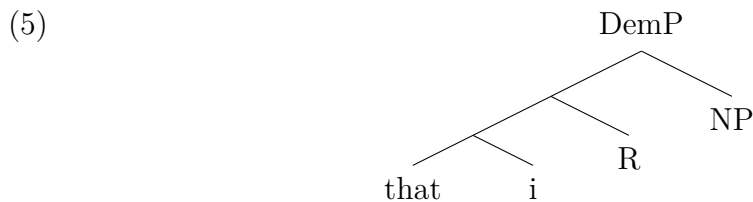

Under this analysis, the *index* *i* or deictic component is a lexical item which identifies the referent. As with Nunberg, the relational variable R is a contextually defined relation between the index *i* and an individual *z*, where *z* is a member of the set of individuals which have the property denoted by NP. Under Elbourne’s approach, the classificatory information, including information about proximity, is carried by the demonstrative head *this* or *that*.

To see how this works, consider a situation in which a speaker gestures toward a distant donkey, who we will call Flossy, and makes the following statement.

(6) [_{DemP} That donkey] is very healthy.

Diverging from Elbourne (2008) slightly, I assume the structure (i) for the demonstrative. A simple mirroring of the demonstrative and the index gives us the proper Hindi word order for the demonstrative while retaining the appropriate scopal relations between the various projections.¹ The shifting of the index *i* and the demonstrative is not only useful for our analysis but reflects that Hindi is right-headed, and avoids a violation of the Final Over Final Constraint (FOFC, Holmberg 2000).

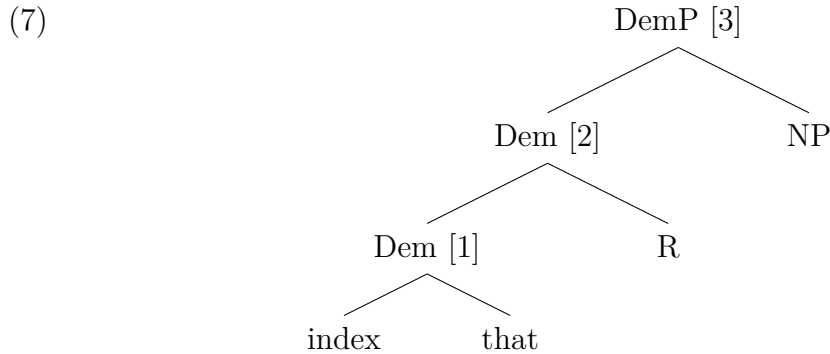

The index *i* itself is a lexical item which is interpreted by means of *Variable Interpretation* (Elbourne 2008, p. 422).

(8) *Variable Interpretation*

For all natural numbers n and assignment functions g , if i_n is a variable with subscript n , then

$$\llbracket i_n \rrbracket^g = g(n)$$

provided n is in the domain of g ; $\llbracket i_n \rrbracket^g$ is undefined otherwise.

In (6), the contribution of the index is simply *Flossy*.

(9) $\llbracket i \rrbracket = \text{Flossy}$

1. At first glance, this structure appears to be quite different from the commonly accepted syntactic structure of the demonstrative phrase. The use of *that* as the deictic component is somewhat misleading. As an indexical, all of the components of deictic *that*, the index *i*, and the relation *R* are part of the demonstrative. That is, the demonstrative itself includes the entire $\llbracket [\text{that } i] R \rrbracket$ constituent.



Before continuing, I am going to use a slightly modified version of Elbourne (2008)'s semantics. Because the semantics for the correlative will also include events, rather than using both events and situations, I assume that events (e) are a variety of the same type as of situations (s). More precisely, events are event-defined situations, or situations defined by the properties of the event, and therefore both events and situations are within the domain $D_{\langle s \rangle}$. I am also suppressing the world parameter as modality will not be part of the current analysis and all situations in the following examples can be assumed to be situated within the actual world. Finally, I simplify the contribution of the NP component slightly so that the NP is of type $\langle et \rangle$ rather than type $\langle se, st \rangle$. This is purely for the sake of convenience and will not affect the analysis.

The demonstrative head carries the classificatory information including culturally specific information regarding deixis, location, and definiteness, as well as geographical anchors, visibility, and tangibility. The lexical entries for the demonstrative *that* and *this* are (10a) and (10b), respectively.² The demonstrative is defined in terms of a contextually salient event e, and its proximity is defined with respect to the actor or speaker (a) at the speech time (t), where h is a variable assignment function. The demonstrative morpheme (*this* or *that* in English) carries the deictic information; I have used the abbreviations DIST and PROX to represent all of the relevant classificatory information including the meaning distal and proximal, respectively. A function *f* introduces the relational component, while a second function *g* introduces the property defined by the NP sortal phrase.

The semantic contribution of the demonstrative looks complicated, but it is really more simple than it seems. In (10), I have broken down the lexical entry

2. Elbourne (2008)'s lexical entry for the demonstrative head, relation R, and the NP *donkey* are given in (ii). In the lexical entries I have assumed, I have reframed the lexical entries in terms of events and suppressed the world variable on the assumption that all of the situations involved in the examples throughout this dissertation are within the actual world.

$$(ii) \quad \llbracket \text{that} \rrbracket^{w,h,a,t} = \lambda x_{\langle e \rangle} . \lambda f_{\langle e, \langle se, st \rangle \rangle} . \lambda g_{\langle se, st \rangle} . \lambda s_{\langle s \rangle} . \iota z (f(x)(\lambda s'_{\langle s \rangle} . z)(s) = 1 \wedge g(\lambda s'_{\langle s \rangle} . z)(s) = 1 \wedge \text{distal}(x, w, a, t))$$

$$\llbracket \text{this} \rrbracket^{w,h,a,t} = \lambda x_{\langle e \rangle} . \lambda f_{\langle e, \langle se, st \rangle \rangle} . \lambda g_{\langle se, st \rangle} . \lambda s_{\langle s \rangle} . \iota z (f(x)(\lambda s'_{\langle s \rangle} . z)(s) = 1 \wedge g(\lambda s'_{\langle s \rangle} . z)(s) = 1 \wedge \text{proximal}(x, w, a, t))$$

$$\llbracket R \rrbracket = \lambda x_{\langle e \rangle} . \lambda u_{\langle s, e \rangle} . \lambda s_{\langle s \rangle} . u(s) = x$$

$$\llbracket \text{donkey} \rrbracket = \lambda u_{\langle s, e \rangle} . \lambda s_{\langle s \rangle} . u(s) \text{ is a donkey in } s$$

for the demonstrative into its separate components to show what each part contributes. The function f , for instance, introduces the relational component of the demonstrative phrase.

$$\begin{aligned}
(10) \quad a. \quad & \llbracket \text{that} \rrbracket^{h,a,t} = \lambda x_{\langle e \rangle} . \lambda f_{\langle e, \langle se, st \rangle \rangle} . \lambda g_{\langle et \rangle} . \lambda e_{\langle s \rangle} . \\
& \iota z(\hspace{15em} \text{(Definiteness)} \\
& f(x)(\lambda e'_{\langle s \rangle} . z)(e) = 1 \hspace{5em} \text{(Relational component)} \\
& \wedge g(z) = 1 \hspace{10em} \text{(NP sortal phrase)} \\
& \wedge \text{DIST}(x,a,t) \hspace{5em} \text{(Deixis and classificatory information)} \\
b. \quad & \llbracket \text{this} \rrbracket^{h,a,t} \\
& = \lambda x_{\langle e \rangle} . \lambda f_{\langle e, \langle se, st \rangle \rangle} . \lambda g_{\langle et \rangle} . \lambda e_{\langle s \rangle} . \iota z(f(x)(\lambda e'_{\langle s \rangle} . z)(e) = 1 \\
& \wedge g(z) = 1 \wedge \text{PROX}(x,a,t))
\end{aligned}$$

Demonstratives in English and Hindi are similar to definite descriptions and include definiteness as part of their denotation. Assuming an Elbourne (2008) style approach to definiteness, a definite determiner has the lexical entry (11).

$$(11) \quad \llbracket \text{the} \rrbracket = \lambda f_{\langle se, st \rangle} . \lambda s_s . \iota x(f(\lambda s'.x)(s) = 1)$$

Note that the meaning of a definite determiner is also assumed to be part of the lexical denotation of the demonstrative head. The iota operator ι is used to the presupposition that there is exactly one individual as described by the phrase. Given the expression $\iota x(f_{\langle se, st \rangle}(\lambda s'.x)(s) = 1)$, for any situation s , $\iota x(f_{\langle se, st \rangle}(\lambda s'.x)(s) = 1)$ will be defined in if there is exactly one entity x such that such that $f(\lambda s'.x)(s) = 1$. If there is not exactly one The lexical entry for the demonstrative reflects each of the components included in its syntax. such entity, then $\iota x(f_{\langle se, st \rangle}(\lambda s'.x)(s) = 1)$ will be undefined and the expression will have no semantic value. For example, assume that f is (12).

$$(12) \quad \lambda u_{\langle se \rangle} . \lambda s_{\langle s \rangle} . u(s) \text{ is a donkey in } s$$

In this case, $\iota x(f_{\langle se, st \rangle}(\lambda s'.x)(s) = 1)$ is equivalent to:

$$(13) \quad \iota x(x \text{ is a donkey in } s)$$

Returning to the demonstrative phrase *that donkey*, the demonstrative head takes the meaning of the index as its first argument. Applying Functional Application, the resulting meaning is (14).

$$\begin{aligned}
(14) \quad \llbracket [1] \rrbracket &= \llbracket \text{that} \rrbracket (\llbracket i \rrbracket) \\
&= \lambda x_{\langle e \rangle} . \lambda f_{\langle e, \langle se, st \rangle \rangle} . \lambda g_{\langle et \rangle} . \lambda e_{\langle s \rangle} . \iota z (f(x)(\lambda e'_{\langle s \rangle} . z))(e) = 1 \wedge g(z) = 1 \wedge \\
&\quad \text{DIST}(x, a, t)(\text{Flossy}) \\
&= \lambda f_{\langle e, \langle se, st \rangle \rangle} . \lambda g_{\langle et \rangle} . \lambda e_{\langle s \rangle} . \iota z (f(\text{Flossy})(\lambda e'_{\langle s \rangle} . z))(e) = 1 \wedge g(z) = 1 \wedge \\
&\quad \text{DIST}(\text{Flossy}, a, t)
\end{aligned}$$

At the next higher node, the meaning of the demonstrative takes the relation projection R as its second argument. In this particular situation, the speaker is pointing to the donkey Flossy and the contribution of DemP is the unique donkey in the context. The relation in this case will simply be an identity relation such that the meaning of the index is the meaning of the interpretation. Where the lexical entry for R is (24), the denotation of Dem (node [2]) is (16).

$$(15) \quad \llbracket R \rrbracket = \lambda a_{\langle e \rangle} . \lambda b_{\langle s, e \rangle} . \lambda e_{\langle s \rangle} . b(e) = a$$

$$\begin{aligned}
(16) \quad \llbracket [2] \rrbracket &= \llbracket [1] \rrbracket (\llbracket R \rrbracket) \\
&= \lambda f_{\langle e, \langle se, st \rangle \rangle} . \lambda g_{\langle et \rangle} . \lambda e_{\langle s \rangle} . \iota z (f(\text{Flossy})(\lambda e'_{\langle s \rangle} . z))(e) = 1 \wedge g(z) = 1 \\
&\quad \wedge \text{DIST}(\text{Flossy}, a, t)(\lambda a . \lambda b_{\langle s, e \rangle} . \lambda e_{\langle s \rangle} . b(e) = a) \\
&= \lambda g_{\langle et \rangle} . \lambda e_{\langle s \rangle} . \iota z ((\lambda a . \lambda b_{\langle s, e \rangle} . \lambda e_{\langle s \rangle} . b(e) = a)(\text{Flossy})(\lambda e'_{\langle s \rangle} . z))(e) \\
&\quad \wedge g(z) = 1 \wedge \text{DIST}(\text{Flossy}, a, t) \\
&= \lambda g_{\langle et \rangle} . \lambda e_{\langle s \rangle} . \iota z (\lambda b . (\iota a (a \text{ is Flossy in } e) = b)(z) \wedge g(z) = 1 \wedge \text{DIST}(\text{Flossy}, a, t)) \\
&= \lambda g_{\langle et \rangle} . \lambda e_{\langle s \rangle} . \iota z (\iota a (a \text{ is Flossy in } e) = z \wedge g(z) = 1 \wedge \text{DIST}(\text{Flossy}, a, t))
\end{aligned}$$

The denotation (16) can then be simplified to (17).

$$(17) \quad = \lambda g_{\langle et \rangle} . \lambda e_{\langle s \rangle} . \iota z (z = \text{Flossy in } e \wedge g(z) = 1 \wedge \text{DIST}(\text{Flossy}, a, t))$$

I will not assume that the denotation of an NP includes situations. An NP such as *donkey* is then defined as (18)

$$(18) \quad \llbracket \text{donkey} \rrbracket = \lambda v_{\langle e \rangle} . v \text{ is a donkey}$$

Taking the NP *donkey* as its third argument, the DemP has the denotation in (19).

$$\begin{aligned}
(19) \quad & \llbracket [3] \rrbracket = \llbracket [2] \rrbracket (\llbracket \text{donkey} \rrbracket) = \\
& = \lambda g_{\langle et \rangle} . \lambda e_{\langle s \rangle} . t z (z = \text{Flossy in } e \wedge g(z) = 1 \wedge \text{DIST}(\text{Flossy}, a, t)) (\lambda v_{\langle e \rangle} . v \\
& \text{ is a donkey}) \\
& = \lambda e_{\langle s \rangle} . t z (z = \text{Flossy in } e \wedge \lambda v_{\langle e \rangle} . v \text{ is a donkey}(z) \wedge \text{DIST}(\text{Flossy}, a, t)) \\
& = \lambda e_{\langle s \rangle} . t z (z = \text{Flossy in } e \wedge z \text{ is a donkey} \wedge \text{DIST}(\text{Flossy}, a, t))
\end{aligned}$$

The meaning of *that donkey* in this situation therefore has the interpretation (20).

(20) *Given a event e, there is a unique individual z such that z is Flossy in e and z is a donkey and Flossy is distal with respect to the speaker (a) at the speech time (t).*

In a situation like this where the speaker is pointing at a donkey and saying *that donkey*, it is difficult to see what the proposed components of the demonstrative are contributing. Because in this example both the index and the interpretation are a donkey, Flossy, and R is simply an identity relation, it does not seem to be saying much more than *the distal donkey named Flossy is a donkey*, which is admittedly redundant.

Consider a case in which the referent is not part of the set picked out by the NP, in which case the role of R is much more apparent. Imagine a situation in which there is a farm which has two donkeys, each living in a separate field (example adapted from Elbourne 2008, p. 431). The speaker is standing looking out over the two fields (Field A and Field B), where Field A is immediately in front of the speaker and Field B is beyond it, at some distance from the speaker. The speaker can then say (21).

(21) This donkey [gesture at Field A] is healthier than that donkey [gesture at Field B].

Importantly, the speaker can make this statement even if neither donkey is in its field at the time. Perhaps both donkeys are at the veterinarian. In this case, neither *this donkey* nor *that donkey* is actually present within the context. The respective donkey, therefore, cannot be the index of either demonstrative. Instead, *this donkey* and *that donkey* are picking out Field A and Field B as their respective index, where Field A and Field B each represent their own respective donkey. ‘Field A is the index ... that brings to mind the donkey that resides in it.’ (Elbourne 2008, p. 430).

At the time of the speech act, where neither donkey is actually in the referenced field, (21) may be roughly interpreted as (22).

(22) The donkey who lives in Field A is healthier than the donkey who lives in Field B.

How is a demonstrative showing deferred reference derived? Below is a derivation of the phrase *this donkey* in a situation where the farmer is pointing at Field A. Each of the components of the demonstrative have the same lexical entry as they do in the direct reference interpretation. The lexical entry for the demonstrative head *this* is (10a). *This* then takes the index, *Field A*, as an argument.

(23) $\llbracket [1] \rrbracket (\llbracket \text{Field A} \rrbracket)$
 $= \llbracket \text{this} \rrbracket^{h,a,t}$
 $= \lambda x. \lambda f_{\langle e, \langle se, st \rangle \rangle}. \lambda g_{\langle et \rangle}. \lambda e. \iota z (f(x)(\lambda e'. z)(e) = 1 \wedge g(z) = 1 \wedge \text{PROX}(x, a, t)) (\text{Field A})$
 $= \lambda f_{\langle e, \langle se, st \rangle \rangle}. \lambda g_{\langle et \rangle}. \lambda e. \iota z (f(\text{Field A})(\lambda e'. z)(e) = 1 \wedge g(z) = 1 \wedge \text{PROX}(\text{Field A}, a, t))$

In this example, the relation R means something like ‘is where the index lives’. R in this example may be defined as follows.

(24) $\llbracket R \rrbracket = \lambda a. \lambda b_{\langle se \rangle}. \lambda e. b(e)$ is where a lives

The meaning contributed by the next higher node, then, is (25)

(25) $\llbracket [2] \rrbracket (\llbracket R \rrbracket)$
 $= \lambda f_{\langle e, \langle se, st \rangle \rangle}. \lambda g_{\langle et \rangle}. \lambda e. \iota z (f(\text{Field A})(\lambda e'. z)(e) = 1 \wedge g(z) = 1 \wedge \text{PROX}(\text{Field A}, a, t)) (\lambda a. \lambda b_{\langle se \rangle}. \lambda e. b(e) \text{ is where a lives})$
 $= \lambda g_{\langle et \rangle}. \lambda e. \iota z (\text{Field A is where } z \text{ lives in } e \wedge g(z) = 1 \wedge \text{PROX}(\text{Field A}, a, t))$

The NP then supplies the information that the individual x contributed by the demonstrative is a donkey. The meaning of the DemP *this donkey* in (21) is (26).

$$\begin{aligned}
(26) \quad & \llbracket [3] \rrbracket (\llbracket \text{donkey} \rrbracket) \\
& = \lambda g_{\langle et \rangle} . \lambda e . \iota z (\text{Field A is where } z \text{ lives} \wedge g(z) = 1 \\
& \wedge \text{PROX}(\text{Field A, a, t})) (\lambda x . x \text{ is a donkey}) \\
& = \lambda e . \iota z (\text{Field A is where } z \text{ lives} \wedge z \text{ is a donkey} \wedge \text{PROX}(\text{Field A, a, t}))
\end{aligned}$$

Roughly, DemP denotes the unique individual a in the situation e where a lives in the proximal Field A and a is a donkey.

In summary, the internal structure of the demonstrative phrase include the demonstrative head Dem, an index, a relation projection R, and an NP sortal head or restrictor. The demonstrative itself takes the meaning of some individual as its index and yields a unique individual which is related to the index through some contextually salient relationship R. In a direct reference reading, the index and the interpretation or individual contributed by DemP will be the same and R is an identity relation. In the deferred reference reading, the index and the interpretation of DemP are distinct but related through R. In the next section, I show how this analysis of the demonstrative can be extended to the correlative construction.

3.3 The correlative as an overt index of the demonstrative

The necessity of a corresponding correlate in the main clause is a defining feature of the correlative construction cross-linguistically. Further, we know that the correlate must be either a demonstrative or a pronominal, both indexicals. In the few exceptions discussed in Section 2.2.2, where the correlate is not a demonstrative or pronoun, Dayal (1996) suggests these alternative correlates are allowed because they, too, are indexical. What is it about the indexicality of the correlate which allows the correlative CP to enter the syntax?

I propose that the correlative clause is as an overt pronunciation of the index of the demonstrative. Syntactically, the correlative enters the syntax as the indexical argument of the demonstrative head. The correlative is then related to the interpretation of DemP in the main clause through the relationship R. Section 3.3.1 presents an analysis of a simple correlative construction in which the NP_{Cor} and the NP_{MC} are the same. In Section 3.3.2 I show how this analysis accounts for correlative constructions in which NP_{Cor} and NP_{MC} are different. The same approach can also be extended to correlative

constructions with pronominal correlates in languages such as Bangla (Section 3.3.3).

3.3.1 The correlative-demonstrative constituent

Consider (27a). Bhatt’s proposed constituent structure for the correlative-demonstrative constituent in which the correlative is adjoined to the DemP is repeated below (27b, see Chapter 2, Section 2.2.2).

- (27) a. *rohī* [_{CorrelP} *d̂ʒo* *kitab* *sera* *ne* *likʰi*
 Rohit which book.F.SG Sera.F.SG ERG write.PFV.F.SG
he] *vo* *kitab* *pəʳʰ* *rəha* *he*
 PRS.3.SG that book.F.SG read PROG.M.SG PRS.3.SG
- ‘Rohit is reading, which book Sera wrote, that book.’ [HINDI]
- b. [[_{CorrelCP} which book Sera wrote] [_{DemP} that book]]

The correlative construction may roughly be described as two sentences or clauses where an argument defined by the correlative CP appears to also be participating in the event defined by the main clause. For example, in (27) there is a book which Sera has written and this same book also participates in the event of Rohit reading.

This is exactly what a demonstrative does. It picks out a referent and allows that referent to participate in the event defined by the main clause through a relation R. This was true for Field A and the donkey. It is also true for the book which Sera wrote and the book which Raam is reading.

What is this going to look like? First, the structure of the demonstrative phrase itself is repeated in (7). The proposed structure of the correlative-demonstrative phrase is shown in (29).

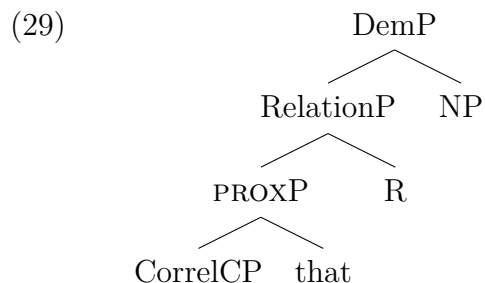
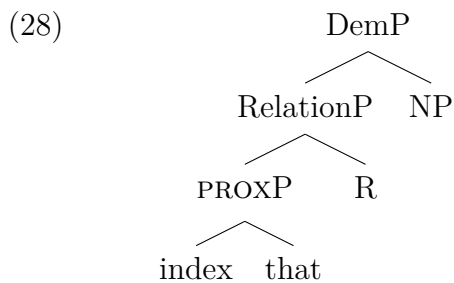

The correlative itself enters the syntax as the index of the demonstrative and an argument of the demonstrative head. Looking at (27), the correlative-demonstrative constituent repeated in (30) will have the constituent structure (31)

- (30) [DemP [CorrelCP $\widehat{d}3o$ *kitab sera ne likhi hε*] [Dem *vo*]]
 which book Sera ERG write.PFV PRS.3.SG that
 ‘which book Sera wrote, that’ [HINDI]

- (31) [DemP [Dem [Dem [CorrelCP which book Sera wrote] that] R] [NP book]]

For now, assume that the CorrelCP in (30) correlative has the semantic contribution in (32). See Chapter 6 for a detailed analysis of the meaning contributed by the correlative. I use a simplified notation for tense and aspect, as it is not relevant to the current discussion. The NP_{Cor} of the relative phrase and NP_{MC} of the demonstrative phrase are both *kitab* ‘book’ and both have the same semantic contribution. I call the semantic contribution of the correlative $\llbracket\text{BOOK}\rrbracket$ so that the following calculations are more transparent.

- (32) Semantic composition of the correlative clause (preliminary)
 $\llbracket\text{which book Sera wrote}\rrbracket = \llbracket\text{BOOK}\rrbracket$
 $= \iota x(\exists e'.x \text{ is the book which Sera wrote in } e')$

This can be read as: *The unique x such that there is a event e' and e' is a (present, perfect) event of Sera writing the book x .*

Turning to the demonstrative phrase, I assume that the semantic composition of the demonstrative and the components within it are the same as the demonstrative in a normal (i.e., non-relativizing) context. But, rather than having an indexical component i , the index of the demonstrative is an overtly pronounced correlative clause. The CorrelCP-DemP constituent, therefore, has the structure in (33).

(33)

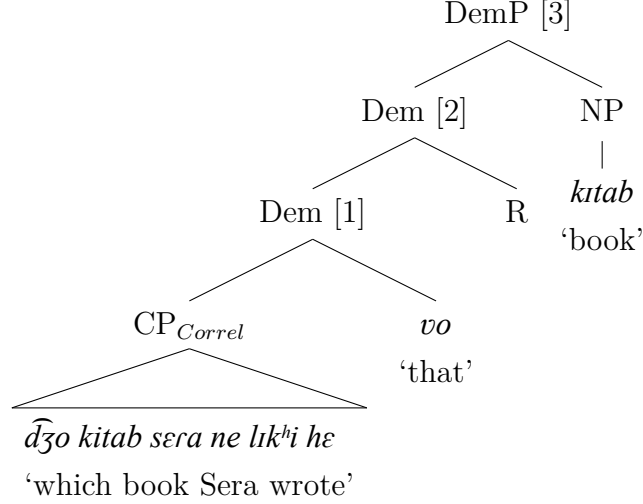

As in Bhatt's analysis, the correlative, the demonstrative, and the NP are all part of a single constituent. Under the analysis proposed here, though, the relationship between the correlative CP and the demonstrative correlate follows directly from the internal structure of the demonstrative itself. We can now see structurally how it is that the demonstrative correlate licenses the correlative to enter the syntax.

Just as the demonstrative head takes a covert index as its argument, *vo* takes the overt CorrelCP $\widehat{dzo} \textit{ kitab sera ne likhi he}$ 'which book Sera wrote' as its argument. Because $\llbracket \text{BOOK} \rrbracket$ is definite, I treat it as if it were a proper name.

$$\begin{aligned}
 (34) \quad & \llbracket \text{that} \rrbracket (\llbracket \text{BOOK} \rrbracket) \\
 & = \lambda x \lambda f_{\langle e, \langle se, st \rangle \rangle} \cdot \lambda g_{\langle et \rangle} \cdot \lambda e \cdot \iota z (f(x)(\lambda e'.z)(e) = 1 \wedge g(z) = 1 \\
 & \wedge \text{DIST}(x, a, t)) (\llbracket \text{BOOK} \rrbracket) \\
 & = \lambda f_{\langle e, \langle se, st \rangle \rangle} \cdot \lambda g_{\langle et \rangle} \cdot \lambda e_{\langle s \rangle} \cdot \iota z (f(\llbracket \text{book} \rrbracket)(\lambda e'_{\langle s \rangle} \cdot z)(e) = 1 \wedge g(z) = 1 \\
 & \wedge \text{DIST}(\llbracket \text{BOOK} \rrbracket, a, t))
 \end{aligned}$$

In this example, R is an identity relationship between $\llbracket \text{BOOK} \rrbracket$, the book which Sera has written, and some argument of type *e* in the main clause, denoted by *z*. Applying R yields the following.

$$\begin{aligned}
 (35) \quad & \llbracket [2] \rrbracket = \llbracket [1] \rrbracket (\llbracket R \rrbracket) \\
 & = \lambda f_{\langle e, \langle se, st \rangle \rangle} \cdot \lambda g_{\langle et \rangle} \cdot \lambda e_{\langle s \rangle} \cdot \iota z (f(\llbracket \text{BOOK} \rrbracket)(\lambda e'_{\langle s \rangle} \cdot z)(e) = 1 \wedge g(z) = 1 \wedge \\
 & \text{DIST}(\llbracket \text{BOOK} \rrbracket, a, t)) (\lambda a. \lambda b. \lambda e. b(e) = a) \\
 & = \lambda g_{\langle et \rangle} \cdot \lambda e_{\langle s \rangle} \cdot \iota z (z = \llbracket \text{BOOK} \rrbracket \text{ in } e \wedge g(z) = 1 \wedge \text{DIST}(\llbracket \text{BOOK} \rrbracket, a, t))
 \end{aligned}$$

The correlative-correlate constituent, which is really a demonstrative phrase (DemP) with an overt, correlative index, has the following contribution.

$$\begin{aligned}
(36) \quad & \llbracket [3] \rrbracket \llbracket \text{which book Sera wrote, that R book} \rrbracket = \llbracket [2] \rrbracket (\llbracket \text{BOOK} \rrbracket) \\
& = \lambda g_{\langle et \rangle} . \lambda e . \iota z (z = \llbracket \text{BOOK} \rrbracket \text{ in } e \wedge g(z) = 1 \wedge \\
& \text{DIST}(\llbracket \text{BOOK} \rrbracket, a, t)) (\lambda x . x \text{ is a book}) \\
& = \lambda e . \iota z (z = \llbracket \text{BOOK} \rrbracket \text{ in } e \wedge z \text{ is a book} \wedge \text{DIST}(\llbracket \text{BOOK} \rrbracket, a, t))
\end{aligned}$$

Finally, replacing $\llbracket \text{BOOK} \rrbracket$ with its semantic contribution, the demonstrative phrase (ie, the correlative-correlate constituent) has the denotation in (37).

$$\begin{aligned}
(37) \quad & \llbracket [3] \rrbracket \\
& = \lambda e . \iota z (z = \iota x (\exists e' . x \text{ is the book which Sera wrote in } e') \text{ in } e \wedge z \text{ is a book} \\
& \wedge \text{DIST}(\iota x (\exists e' . x \text{ is the book which Sera wrote in } e'), a, t))
\end{aligned}$$

The meaning of the DemP $\widehat{d_3o}$ *kitab sera ne likhi he vo* ‘which book Sera wrote, that’ may be paraphrased as (38).

$$(38) \quad \textit{The unique } z \textit{ such that, given some event } e, z \textit{ is a book in } e \textit{ and } z \textit{ is the unique } x \textit{ there is an event } e' \textit{ and Sera write } x \textit{ in } e' \textit{ and } x \textit{ is distal with respect to the speaker (a) at the speech time (t).}$$

Notice that the two independent noun phrases, though they both happen to be *kitab* ‘book’, each make their own semantic contribution. This follows from there being two variables in the final composition, x and z , which each independently have the property of being books.

To conclude, in this section I have shown that if the correlative clause is an overt pronunciation of the index of the demonstrative, this gives the right semantic denotation for the entire correlative construction. Further, unlike previous accounts, it is clear under this approach why the demonstrative requirement is so central to the correlative construction. In the Section 3.3.2, I give an example of the derivation of a correlative construction involving two different NPs. Section 3.3.3 shows how this analysis extends to pronominal correlates.

3.3.2 Dual headedness in the correlative construction

In Chapter 2, Section 2.2.2, I showed that that Hindi and Marwari not only allow an overt nominal to appear in both the correlative clause and the main clause, but that those noun phrases do not have to be the same as long as they refer to the same entity. (39) is an example of this. The correlative

- (44) $\llbracket [2] \rrbracket$
 $= \lambda g_{\langle et \rangle} . \lambda e_{\langle s \rangle} . \iota z [z = \iota x (\exists e'. x \text{ is the man Sita bought her refrigerator from in } e') \text{ in } e \wedge g(z) = 1 \wedge \text{DIST}(\iota x (\exists e'. x \text{ is the man Sita bought her refrigerator from in } e'), a, t)]$

Finally, the demonstrative take the NP *dukəndar* as its final argument. The denotation of the correlative-correlate constituent – which is really a demonstrative phrase DemP – is (45).

- (45) $\llbracket [\widehat{d}z\text{is adm\i se sita ne əpni fr\i d}z\text{ k}^h\text{arid}^h\text{i vo dukəndar}] \rrbracket = \llbracket [3] \rrbracket$
 $= \lambda e . \iota z (z = \iota x (\exists e'. x \text{ is the man Sita bought her refrigerator in } e') \text{ in } e \wedge z \text{ is a storekeeper} \wedge \text{DIST}(x, w, a, t))$

The demonstrative phrase has the interpretation:

- (46) The unique z such that, given an event e , z is the unique x in e and there is some event e' of Sita buying her refrigerator from the man x in e' , and z is a storekeeper and z is distal with respect to the speaker at the speech time.

This is perfectly grammatical and is interpretable. A similar construction would, of course, fail if there were no contextually salient relationship between the demonstrative and its interpretation.

3.3.3 Pronominal correlates in Bangla

If the correlative in languages like Hindi and Marwari is the overt pronunciation of a demonstrative correlate, what about languages like Bangla which use a pronominal correlate? An example of this is (47, repeated from Chapter 2, Section 2.2, example (3). In this construction, the correlative *je meye-Ti dariyaganj-e thake* ‘which girl stays in Dariyaganj’ relates to a pronominal correlate *Se* ‘she’.

- (47) [*je meye-Ti dariyaganj-e thake*] *Se khub*
 which girl-CL Dariyaganj.NAME-LOC stays PRO.3.SG very
bhalo gan gay
 good sings song

‘Which girl stays in Dariyaganj, she sings very well.’ (*from*
 Ishani Guha, p.c.)

[BANGLA]

It is not a coincidence that, cross-linguistically, both options for a correlate are indexicals. In fact, the demonstrative has largely the same semantic contribution as a pronoun except that it includes information about the proximity of the referent. Both relate some index or reference to an argument in the main clause, and both pronouns and demonstratives can be interpreted as definite descriptions. For these reasons, among others, Elbourne (2008, p. 417) concludes that ‘demonstratives are basically pronouns with noun phrases added to them.’

To demonstrate this, consider an example in which the speaker is listening to a speech given by Pope Benedict XVI (from Recanati 2005, credited to Nunberg; adapted by Elbourne 2008). The speaker gestures toward Benedict XVI and says the following.

(48) He is usually Italian.

Under a direct reference account, this is equivalent to:

(49) Benedict XVI is usually Italian.

(49) can only mean that Benedict XVI is usually Italian, but sometimes he is some other nationality. This is not the intended reading of (48). Rather, the intended meaning is that the position of the pope, represented by Benedict XVI, is usually held by someone who is Italian.

Similar to the demonstrative, the pronoun has a deictic component which picks out the index and a relational component denoting a contextually salient relation between the index and the interpretation, where the interpretation participates in the main clause.

Elbourne (2008) proposes the following structure for the English pronoun *it*.

(50) [it [R *i*]]

Unlike the demonstrative, R and *i* are constituents, reflecting that in the pronoun there is no intervening distal information which scopes over the index.

Returning to our example, the value of *i* is ‘Benedict XVI’. Since the most salient relation between Benedict XVI and the interpretation is that of holding the office of the Pope, applying the relation R will yield the meaning in (51).

(51) $\lambda s.\iota x.x$ holds the office held in w_0 at t_0 by Benedict XVI

This is equivalent to:

(52) $\lambda s.\iota x.x$ is the Pope in s

Consider again the Bangla example and the correlative-pronominal correlate constituent.

(53) [*je meye-Ti dariyaganj-e thake*] *Se*
 which girl-CL Dariyaganj.NAME-LOC stays PRON.3.SG
 ‘which girl stays in Dariyaganj, she’

Modifying the ordering of the constituents to reflect the word order of Bangla while maintaining the hierarchal structure, the Bangla pronoun *Se* ‘she’ has the internal structure shown in (54). Note that pronouns are structured slightly differently than demonstratives (Elbourne 2008). In pronouns, the relation *R* takes the index, rather than an [*i Dem*] constituent, as its argument. I call the [*i R*] constituent *RelationP*.



In the case of (53), where the index is the overtly pronounced correlative, the structure of the pronominal phrase is (55).

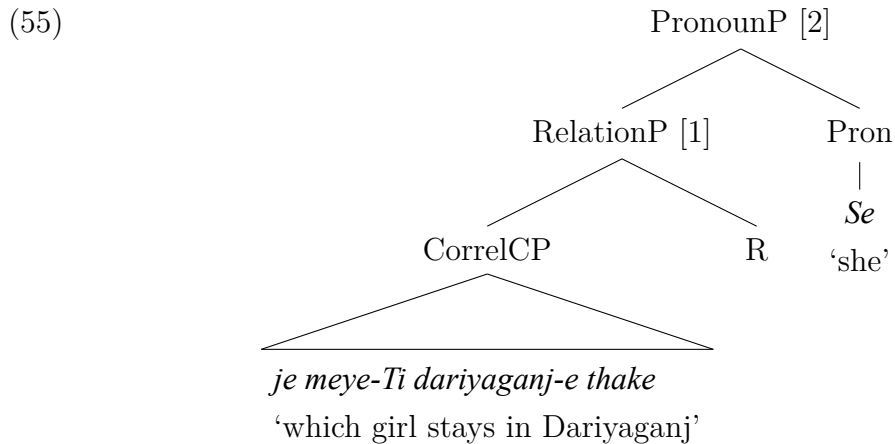

Below, I demonstrate how the meaning of the correlative-pronominal constituent is derived.

I assume that Bangla pronouns have the same semantic contribution as Elbourne's *it* but with different number and gender agreement.

$$(56) \quad \llbracket \text{Se} \rrbracket = \llbracket \text{it} \rrbracket = \lambda f_{\langle se, st \rangle} . \lambda s . \iota z (f(\lambda s'.z)(s)) = 1$$

In (47), the pronoun acts like a referential pronoun and R is simply an identity relation with the same meaning as the identity relation in the demonstrative phrase.

$$(57) \quad \llbracket \text{R} \rrbracket = \lambda a . \lambda b_{\langle se \rangle} . \lambda e . b(e) \text{ is the job or role represented by a}$$

In a simple case, where the covert index is Benedict XVI, the semantic contribution of RelationP is (58).

$$(58) \quad \llbracket [2] \rrbracket = \llbracket \llbracket \text{R} \rrbracket \rrbracket (\llbracket \text{Benedict XVI} \rrbracket) = \lambda b_{\langle se \rangle} . \lambda e . b(e) \text{ is the role represented by Benedict XVI}$$

Turning to the correlative construction, where the index is a correlative, R will take the correlative as its argument. For now, I assume that the correlative has the following contribution.

$$(59) \quad \llbracket \text{which girl stays in Daryaganj} \rrbracket \\ = \iota x (\exists e'. x \text{ is the girl who lives in Daryaganj in } e')$$

RelationP of (55) has the meaning (60).

$$(60) \quad \llbracket [1] \rrbracket = \llbracket \llbracket \text{R} \rrbracket \rrbracket (\llbracket \text{which girl stays in Daryaganj} \rrbracket) \\ = \lambda b_{\langle se \rangle} . \lambda e . b(e) = \iota x (\exists e'. x \text{ is the girl who lives in Daryaganj in } e')$$

The pronoun takes the relation phrase as its argument. The composition of the correlative-correlate in example (53), which is really just a pronominal phrase, has the following denotation.

$$(61) \quad \llbracket [2] \rrbracket = \llbracket \llbracket \text{Se} \rrbracket \rrbracket (\llbracket [1] \rrbracket) \\ = \lambda f_{\langle se, st \rangle} . \lambda s . \iota z (f(\lambda s'.x)(s) = 1) (\lambda b_{\langle se \rangle} . \lambda e . b(e) = \iota x (\exists e'. x \text{ is the girl who lives in Daryaganj in } e')) \\ = \lambda f_{\langle se, st \rangle} . \lambda s . \iota z (z = \iota x (\exists e'. x \text{ is the girl who lives in Daryaganj in } e')) \text{ in } e)$$

Again, both the syntactic and the semantic relationship between the correlative and the pronominal correlate is clear and follows directly from the internal structure and composition of the correlate phrase. In the same way that the correlative is able to enter the syntax as the index of a demonstrative, it may alternatively act as the overtly pronounced index of a pronominal correlate.

3.3.4 A note on bare demonstratives

In all of the examples so far, the correlate is a DemP which includes an overt NP. In Section 2.2.2.2, we saw that it is also possible for the correlate phrase to be a bare demonstrative. That is, the demonstrative can appear without an overt noun phrase. This is similar to bare demonstratives in English, such as *that* in (62).

(62) That is tall.

This is not unexpected as languages like Hindi (as well as Marwari, Punjabi, and other MIA languages) use a demonstrative pronoun, or a demonstrative without an overt NP, rather than a pronoun. While bare, these are true demonstratives with the internal structure introduced in Section 3.3.

Like demonstratives, demonstrative pronouns are similarly definite and also select an index, but they still include a deictic component containing information about the proximity of the referent.

(63) *vo lāmbi hε*
that tall.F.SG be.PRS.3.SG

'That is tall.'

[HINDI]

In an example like (63), like the pronoun, the bare demonstrative *vo* 'that' does not take an apparent NP. Yet, while bare, *vo* 'that' still carries the proximity information distal or proximal.

How do we reconcile the possibility of a bare demonstrative with the fact that the semantic value of the demonstrative requires an NP or predicate of type <e,t> in order to be interpreted? This can be resolved 'quite naturally' if we suppose that a truth-conditionally trivial property is contributed to the semantics as the second argument of *that* in cases of bare demonstratives' (Elbourne 2008, p. 437).

King (2001) suggests that a sentence with an surface form like example (64a), where F is a predicate. The demonstrative is interpreted as having an empty or covert constituent in place of the overt NP (n)⁴, with the syntactic structure as in (64b).

- (64) a. Overt pronunciation: [[That] [_{VP} is F]
 b. Syntactic Structure: [[[That] [n]] [_{VP} is F]]

King offers several options for how we might think of the semantic contribution of the covert NP. First, it is possible that the null NP is ‘somehow determined by the context of utterance’ (King 2001, p. 142). In our example (63), perhaps n is interpreted as a covert *laḡki* ‘girl’. This, King admits, is less preferable than the following two options, perhaps because it would require a more rigorous account of how e gets its meaning from the context.

Second, the covert NP may contribute the property of *being identical to b*, where b is the referent picked out by the demonstrative itself, i.e., the index.

- (65) [[[That= b] [= b]] [is F]]

A third possibility is that the empty node e contributes ‘the same property that is always possessed by everything that exists, ... [that] of *being a thing*’ (King 2001, p. 143). Alternatively, but along similar lines, Elbourne (2008) suggests that there is a phonologically null ONE with a meaning of *is an individual of type e*.

Regardless of which analysis we choose, what is important here is to note that a demonstrative pronoun is not a true pronominal but a *bare demonstrative* and has the same underlying structure and semantic contribution as that of a full demonstrative phrase.

3.3.5 Correlative fronting: Subject and Adjunct Islands

In Chapter 2, I summarized Bhatt (2003)’s arguments that the correlative must be base-generated adjacent to the demonstrative. One evidence for this was the inability of a correlative to raise out of a postnominal relative clause island or out of a coordinated structure. In some languages, subject and adjunct phrases act as islands, as well. If these were islands in Hindi or other

4. King (2001) calls the covert constituent which replaces the overt NP e . I call it n , instead, so that it is not confused with e used as a semantic type.

MIA languages, this would prevent the correlative from raising to a fronted position, which is the position where it most often appears.

Hindi and other MIA languages are known for frequently raising an argument to a fronted position (also referred to as *scrambling*). Not only can an argument raise, but it is possible to front an argument or adpositional phrase out of an argument phrase. For example, in (66), it is possible for the possessor to raise out of the object phrase *ram ki kitabẽ* ‘Raam’s books’ to a fronted position so that the possessor *ram ki* ‘Raam’s’ is separated from the possessee *kitabẽ* ‘books’ (66b).⁵

- (66) a. *sita ko lægta he ki mudʒʰe* [PossP *ram*
 Sita DAT feels.IMPFV.M.SG PRS.3.SG COMP I.OBL-DAT Raam
ki kitabẽ] *pəsənd hẽ*
 of.F.PL book.F.PL liking be.PRS.3.PL
 ‘Sita feels that I like Raam's books.’

- b. [*ram ki*]_i *sita ko lægta he ki*
 raam of.F.SG Sita DAT feels.IMPFV.M.SG PRS.3.SG I.OBL-DAT
mudʒʰe [PossP *t_i kitabẽ*] *pəsənd hẽ*
 book.F.PL liking be.PRS.3.PL
 ‘Sita feels that I like Raam's books.’
Lit: ‘Raam's, Sita feels that I like (his) books’.

As (67a) and (67b) show, subjects are also not islands for movement in Hindi. In (67a), the possessive phrase *ram ki kitabẽ* ‘Raam’s books’ is the subject of the embedded clause *ram ki kitabẽ kʰub bikẽgi* ‘Raam’s books will sell well’. It is perfectly felicitous in Hindi for the possessor *ram ki* ‘of Raam’ to raise out of the subject to a fronted position.

- (67) a. *sita ko lægta he ki* [PossP *ram ki*
 Sita DAT seem.IMPFV.M.SG PRS.3.SG COMP Raam of.F.PL
kitabẽ] *kʰub bikẽgi*
 book.F.PL well sell.FUT.3.F.PL
 ‘Sita feels that Raam's books will sell well.’

5. With much thanks to Rajesh Bhatt for the data in this section.

- b. [*ram ki*]_i *sita ko lagta he ki*
 Raam of.F.SG Sita DAT seem.IMPFV.M.SG PRS.3.SG COMP
 [_{POSSP} *t_i kitabẽ*] *k^hub bikẽgi*
 book.F.PL well be-sold.FUT.3.F.PL

‘Sita feels that Raam's books will sell well.’

Lit.: ‘Raam's, Sita feels that (his) books will sell well.’

It is also possible for the possessor phrase to raise out of the subject, away from the possessed NP, and over an adverbial phrase such as *ad̤z̤* ‘today’.

- (68) a. *ad̤z̤ ram ki kitabẽ k^hub biki*
 today Raam of.F.PL book.F.PL well sell.PFV.F.PL

‘Today, Raam's books sold well.’

- b. *ram ki ad̤z̤ kitabẽ k^hub biki*
 Raam of.F.PL today book.F.PL well sell.PFV.F.PL

‘Ram's books sold well today.’

Lit.: ‘Raam's, today (his) books sold well.’

The fact that the possessor phrase is able to move out of the subject is evidence that subjects are not islands in Hindi and other MIA languages. There is, therefore, no restriction on the correlative clause raising out of a demonstrative phrase subject to a fronted position, as well.

Like subject, adjuncts also do not act as islands in Hindi, and presumably Marwari and other MIA languages. In (69a), the possessor phrase *namita ke* ‘Namita’s’ is embedded inside of a locative adposition phrase *namita ke g^har se* ‘from Namita’s house’. The possessor phrase may then raise from the adpositional phrase to a fronted position (69b).

- (69) a. *həm [pp namita ke g^har se] aje*
 we Namita of.OBL.M.SG house.OBL.M.SG from come.PFV.M.PL

‘We came from Namita's house.’

- b. [*namita ke*]_i *həm* [PP t_i *g^har* *se*]
 Namita of.OBL.M.SG we house.OBL.M.SG from
aje
 come.PFV.M.PL

'We came from Namita's house.'

Lit.: 'Namita's, we came from (her) house.'

From these examples, it is clear that subjects and adjuncts are not islands in Hindi and MIA languages and the proposed analysis presented here does not conflict with other aspects of Hindi and Marwari grammar. This does predict that languages which do have subject and adjunct islands will have more restrictions on the fronting of correlatives, and that they will therefore be limited in when multi-headed correlatives can occur, as well (see Chapter 7).

3.4 Implications and Predictions

If the correlative is an overt pronunciation of the indexical component of the correlate phrase, then this predicts that the correlative may act as the argument of other indexicals, as well. In this section, I present a few examples which show that this is the case. First, in Section 3.4.1, I show that a proximal demonstrative is also able to act as a correlate in the correlative construction. Section 3.4.2 demonstrates that it is also possible for a correlative to act as the index of first and second person pronouns in Marwari.

3.4.1 The proximity of the index

Nunberg points out that the demonstrative or deictic component of demonstrative indexicals is associated with the index rather than the referent (Nunberg 1993, p. 23; cf. Elbourne 2008, p. 430). In a sentence like 'This donkey is healthier than that donkey', the demonstratives *this* and *that* refer, not to the proximity of the donkey in question but to the relative proximity of the index, the field being pointed to. The donkey in Field B may very well have wandered over the neighbor's house while the donkey in the (proximal) Field A may be further away at the veterinarian clinic. For this reason, *this* or *that* scopes over the index, and not R, so that the proximity contributed by the demonstrative

head refers only to the index and not to the individual contributed by the interpretation.

The demonstrative in the correlative-correlate construction does not pick out a referent or index in the physical context but selects an individual defined by a salient event. The deictic information carried by the demonstrative, then, cannot refer to a physical proximity. Rather, the proximity of the entity defined by the correlative is in a sense metaphorical. This usage of the demonstrative is common in discourse and is sometimes called *discourse deixis* (Webber 1988).

Because this is a metaphorical use, and because discourse deixis is not marked independently from the stereotypical demonstrative, I assume that this type of usage is based on pragmatic factors and that the deictic component of the correlative construction still has the same semantic composition as the more literal usage of the demonstrative.

The analysis outlined in Section 3.3.3 predicts that both the proximal and the distal demonstratives should be available as correlates. This proves to be the case in Hindi and Marwari (see examples (70a) and (70b)⁶), and I hypothesize that it will hold for other MIA languages as well.

- (70) a. [$\widehat{d}zo$ $l\grave{a}rki$ $k^h\grave{a}r\grave{i}$ $h\epsilon$] $j\epsilon$
 which girl.F.SG standing.F.SG be.PRS.3.SG this
 ($l\grave{a}rki$) $l\grave{a}mbi$ $h\epsilon$
 girl.F.SG tall.F.SG be.PRS.3.SG
 ‘Which girl is standing, this (girl) is tall.’ [HINDI]
- b. [$\widehat{d}ziki$ $\widehat{t}^h\grave{o}ri$ ubi $\text{?}\epsilon$] a
 which girl.F.SG standing.F.SG be.PRS.3.SG this.F.SG
 ($\widehat{t}^h\grave{o}ri$) $d\grave{i}g:i$ $\text{?}\epsilon$
 girl.F.SG tall.F.SG be.PRS.3.SG
 ‘Which girl is standing, this (girl) is tall.’ [MARWARI]

Admittedly, this is very rare, and both the Hindi and Marwari examples were elicited during fieldwork and not in natural speech.⁷ There are undoubt-

6. Rajesh Bhatt (p.c.) notes that example (70a) is only acceptable if it is in present tense. It is ungrammatical in the past tense, and it is infelicitous in written Hindi. The use of the proximal demonstrative *je* ‘this’, therefore, is related to the speech situation and has more restrictions on use than the distal demonstrative.

7. Several informants in each language confirmed that these are acceptable.

edly several pragmatic factors at play here related to the discourse usage of the proximal demonstrative, including discourse deixis. While rare, the ability of a proximal demonstrative to act as a correlate supports the conclusion that it is the indexicality of the demonstrative which allows the correlative to enter the syntax.

3.4.2 First and second person correlates

While many MIA languages do not have third person pronouns, as is the case with Hindi and Marwari, they do have first and second person pronouns. If the correlative is the overt pronunciation of the index, then it holds that it should be able to act as the index of first and second person pronouns, as well.

I tested this type of construction with three consultants, including one speaker of Jodhpuri Marwari (Sunil) and the two speakers of Osian Marwari. While Sunil accepted all of the examples involving first and second person pronouns, the Osian Marwari speakers only accepted the second person plural as a correlate.

All three speakers agreed that correlative constructions involving both inclusive and exclusive first person plural pronouns are acceptable. In (71),⁸ the correlative *ḍziko got^h mē avəṇu tʃ^have* ‘which (of you) want to go to the party’ corresponds to the first person plural exclusive pronoun *ap:a* ‘we.INCL’.⁹

8. Rajesh Bhatt (p.c.) suggests that the correlative may not be restricting *ap:a* ‘we.INCL’ in this particular example but that (71) could potentially be interpreted as ‘irrespective of who wants to come, we are leaving now’. More investigation is required to suss out the precise meaning of these examples.

9. In (71), which is from the Osian variety of Marwari, both the relative pronoun *ḍziko* ‘which’ and the verb of the main clause *halo* ‘move’ end in *-o*, which usually marks masculine singular agreement in Marwari. The subject of the matrix clause in both is plural. Unlike perfective VPs which can trigger a covert ergative case-marking which blocks agreement, the VP here is both intransitive and subjective; there is nothing to block agreement with the subject. Similarly, the correlative is associated with a plural demonstrative, and the agreement on the *wh_{RC}*-element should also be plural.

This is not the only example of this kind which occurred in Osian Marwari during fieldwork. I therefore suspect that this is not a case of mismatched or conflicting agreement but a matter of variation. Some of the other variation between Osian Marwari and the other varieties also involved pronouns and agreement, so there is reason to believe that this is the case.

(74) [The teacher, having forgotten which student forgot their homework,
says:]

* / ✓ [PronP [CorrelCP *d̄ʒəko* *t̄ʰoro* *apro* *girekʰarija gəma*
which.M.SG boy.M.SG own.M.SG homework lose
dijo] *tʰu* *mare kən(ɛ) aav*
give.LGT.PFV.M.SG you.FAM my side come.2.IMP.FAM

'Whoever it was that lost their homework should come see me.'

Lit.: 'Which boy lost your homework, come see me.' [MARWARI]

Finally, for some speakers it is also possible for the correlate to act as the index of a first person pronoun. In (75), for instance, *d̄ʒiko mistri tʰari motosajkəl havəl kari* 'which mechanic fixed your motorcycle' is an overt index of the pronoun *mē* 'I'.

(75) [PronP [CorrelCP *d̄ʒiko* *mistri* *tʰari* *motosajkəl havəl*
which.M.SG mechanic your.F.SG motorcycle repair
kari] *mē*] *abe d̄ʒaũ* *hũ*
do.PFV.F.SG I now go.SUBJ.1.SG PRS.1.SG

'I, the mechanic who fixed your motorcycle, need to leave now.'

Lit.: 'Which mechanic fixed your motorcycle, I need to
leave now.' [MARWARI]

Sunil, a Marwari speaker from Sarechan, said that he would only be able to say (75) felicitously if he were the mechanic. This is further confirmation that the correlative is being associated with the first person pronoun *mē*. Both Osian Marwari speakers, though, said that (75) is unacceptable even in the same situation.

There is a possible reason why first person singular and second person pronouns to be may be unable to act as correlates. I suggest that the reason that a correlative cannot act as the overt index of these pronouns, at least for some speakers, is because the meaning of the index is too closely tied to the speaker (in the case of the first person singular) or the listener (in the case of second person pronouns). Because correlatives are innately third person, the index of the pronoun cannot pick out the individual denoted by the correlative as its index.

3.5 Deferred Reference in Correlatives

If the correlative clause is the index of the demonstrative (or pronoun, as appropriate), then the same type of deferred reference should appear in the correlative construction, as well. These will be cases in which the individual denoted by the correlative is different from the interpretation in the main clause. While deferred reference is more restricted in correlatives than in demonstratives which do not have an overt index, it is indeed possible.

Recall Elbourne (2008)'s example of deferred reference in pronominals discussed in Chapter 3. (This example is originally from Recanati 2005, credited to Nunberg; adapted by Elbourne 2008.) Given a situation in which Pope Benedict XVI is speaking in front of a large crowd. The speaker gestures toward Benedict XVI and says (76).

(76) He [gesture toward Benedict XVI] is usually Italian.

In this case, Benedict XVI is the index while the interpretation is the person holding the position of pope.

It is possible to see the same kind of deferred reference in Marwari. At a yearly, local festival in Jodhpur a *b^hopa* sings the story of a local god called *goganəvəmi*. During one of these yearly festivals, a speaker may gesture toward this year's *b^hopa*, who happens to be from the Marwar region, and say the following.

(77) *vo ləgeʔəge marwar ũ ni hɛ*
 that.M.SG usually Marwar SRC NEG be.PRS.3.SG

'That [gesture toward the bhopa] is usually not Marwari (but this year he is).'
 [OSIAN MAR.]

Like the Pope Benedict XVI example (76), the index of (77) is the woman who is singing but the interpretation is that *the b^hopa* is usually not Marwari.

Marwari also allows a correlative to show the same kind of deferred reference. Consider a similar situation, except that this year's *b^hopa* is a woman – something which is unusual, but not impossible. The speaker now gestures at the *b^hopa* and makes the statement in (78).

- (78) [*d̂ʒiki* *lugai* *gave* *hɛ*] *ba* *amtopər*
 which.F.SG woman.F.SG sing.IMPFACT PRS.3.SG that.F.SG usually
 mɪnək *hɛ*
 man.M.SG be.PRS.3.SG

'Which woman is singing, that is usually a man.' [OSIAN MAR.]

As is often the case with deferred reference, (78) was not entirely acceptable for all speakers. One speaker from Sarechan found it to be somewhat degraded. Instead, he suggested that the main clause be 'that is usually a man's work.'¹⁰ Note that this is also an example of deferred reference, so this is not a counterexample even if (78) is infelicitous.

In another example of deferred reference in correlatives (79), the nominal correlative *d̂ʒəki t̂ʃap b^{hit} mat^he lagori ʔe* 'which poster is hanging on the wall' is an argument of the demonstrative phrase *ba DVD*.

- (79) *ɪmɾan* [*d̂ʒəki* *t̂ʃap* *b^{hit} mat^he lagori ʔe*] *ba*
 Imran which.F.SG poster.F.SG wall on hung be.PRS that.F.SG
 DVD *mol li*
 DVD.F.SG buy take.LGT.PFV.F.SG

'Imran bought, which poster is hanging on the wall, that DVD.' [OSIAN MAR.]

Here, the index of the demonstrative is the poster hanging on the wall, while the interpretation is the DVD related to that poster. Assuming that this is a movie poster, the relation may be 'the DVD of the film advertised in that poster'. It is also possible that the poster is the cover a book. The interpretation of (79) is that Imran bought DVD of the film which was based on that book.

Significantly, (79) cannot get the intended interpretation if the NP_{MC} is absent, as in (80).

10. It is possible that this was degraded because he found it infelicitous for the bhopa to be a woman. The same speaker did find other deferred reference examples, including the others given later in this section, felicitous.

(80) # *imran* [*ḍʒəki* *tʃap* *bʰit matʰe lagori* *ʔe*]
 Imran which.F.SG poster.F.SG wall on hung.F.SG be.PRS
ba *mol li*
 that.F.SG buy take.LGT.PFV.F.SG

Intended: 'Imran bought, which poster is hanging on the wall, that DVD.'

[OSIAN MAR.]

Both of these examples relate to nominal correlatives.

While deferred reference is possible in the correlative construction, it is more restricted than what we find in non-correlate demonstratives. There are cases where one might expect deferred reference to be available and it is not. For example, deferred reference is possible in (81) where the index is covert, but it is not available in what seems like a near equivalent correlative construction, (82).

Suppose that Vijay and his friends are at a museum. Vijay does not care for many of the displays, but there is one painting which he particularly likes. Gesturing toward this painting, Vijay might say the following:

(81) *vasa!* *o* *ḍʒaṇa* *he* *ke* *kikar tʃitr*
 wow! this.M.SG knowing PRS COMP how_Q drawing/painting
bəṇaya *he*
 make.M.SG PRS.3.SG

'Wow! He [gesture at painting] knows how to paint!'

[OSIAN MAR.]

The index of the demonstrative *o* 'that' in (81) is the painting which Vijay is pointing at. The interpretation of the DemP, though, is the painter who made the painting.

Given that (81) is acceptable, it seems that (82) should be acceptable as well, but this is not the case. (82) was bad for all of the four speakers it was checked with.

- (82) * [*d̥ʒəko t̥ʃitr vikrəm ləndān ũ lajo*] *o*
 which painting Vikram London SRC bring.PFV.M.SG that.M.SG
d̥ʒa-ŋa he ke kīkar t̥ʃitr bəŋaja he
 know.INF PRS.3.SG COMP how_Q painting make.PFV.M.SG PRS.3.SG

Intended: 'Which painting Vikram brought from London, he knows how to paint.' [OSIAN MAR.]

Marwari speakers similarly rejected a correlative construction based on Elbourne (2008)'s example involving the donkeys and their fields. In a situation where a farmer has two donkeys living in two different fields, one which is nearby and one which is further away, (83) is felicitous in Marwari even when both donkeys are away at the vet.

- (83) *o gədo uŋ-ũ bəto təgədo hẽ*
 this.M.SG donkey.M.SG that.OBL-SRC more healthy be.PRS.3.PL

'This donkey [gesture at Field A] is healthier than that one.' [MARWARI]

In (83), the index of the demonstrative phrase *o* 'this' is the field which the speaker is gesturing toward, but the interpretation is the donkey who is known to live in that particular field.

While (83) is acceptable, a similar construction in which the index is made explicit is not. Even when I used the same drawing to illustrate the situation and tested both (83) and (84) with the same speakers, (84) was consistently rejected.¹¹

11. Rajesh Bhatt (p.c.) points out that, while the Hindi equivalent of (84) is also unacceptable, changing the NP_{MC} from *vo* 'that' to *vo vala* is moderately better.

- (ii) ? [*d̥ʒo k̥het g̥har ke pas he*] *vo vala rod̥ʒ*
 which field.M.SG house.OBL.M.SG near be.PRS.3.SG that one/thing daily
bimar he
 sick be.PRS.3.SG

'Which field is near the house, that donkey is always sick.'

[HINDI]

The word *vala* in Hindi (or *a/a* in Marwari) does not have an equivalent in English but means something like 'one' or 'thing'. In the case of example (ii), *vo vala* would be interpreted as something like 'that field-thing'.

Another Hindi speaker, though, said that this can only be interpreted to mean that the field itself is sick. Like other examples, speakers seem to differ in how flexible they allow R to be.

- (84) * [*d̥ʒako kʰet* *gʰar* *kənɛ ʔɛ*] *bo*
 which field.M.SG house.M.SG near be.PRS.3.SG that.M.SG
 gədo
 donkey.M.SG
 rodzina bemar revɛ
 daily sick keep.IMPFACT.PRS.3.SG

'Which field is near the house, that donkey is always falling sick.'

[OSIAN MAR.]

While it is not entirely clear why some correlative constructions allow deferred reference and others do not, there are a few factors which seem to affect when deferred reference is available. The first is that the relation R is not as free as Nunberg (1993) supposes.

Nunberg assumes that R can be any relationship which is contextually salient, but there are cases even in English where a highly salient relationship still cannot yield the right interpretation. For example, suppose that our farmer has bought two new cows and put one cow in each field, so that one donkey and one cow are living in each field. (This example is adapted from Elbourne 2008, whose example involved two donkeys in each field.) In fact, each donkey and cow duo have become such good friends that they are practically inseparable. Fiona the cow is very rarely seen without Flossy the donkey, and Esmerelda the donkey cannot bear to be apart from her best friend Elmer the cow. Today, Flossy and Esmerelda are away at the vet, while their own friends have been left at home in their respective pastures. Suppose the farmers were to gesture to the two cows and say (85).

- (85) #This donkey [gesture toward Fiona the cow] is healthier than that donkey [gesture toward Elmer the cow].

Given our previous example, this seems like it should be felicitous, but it is not.

The same infelicity arises when we reverse the roles of the donkey and the field. Suppose the farmer is at the vet with the two sick donkeys from example (83). Explaining to the vet what precautions he has taken so far to prevent further illness, the farmer might make the following statement:

(86) #This field [gesture toward Flossy the donkey] has been sprayed for mosquitoes but that field [gesture toward Esmerelda the donkey] has not.

From these examples, it is clear that R cannot be any relationship which is contextually salient. There are some cases in which, no matter how familiar the speaker and listener are with the situation, the R relation still cannot give the correct interpretation.

The second reason that an indexical might not allowed deferred reference may be related to limitations on deferred reference in demonstratives. There are cases where a pronoun has been argued to allow a distinction between the index and the interpretation, but a demonstrative in the same situation does not.

Consider the same situation we saw in (76), in which Benedict XVI is speaking to a large crowd. A speaker might gesture toward Benedict XVI and make the statement in (87).

(87) That man [gesture toward Benedict XVI] is usually Italian.

Speakers vary as to whether (87) is acceptable or not, but all of them seem to agree that it is definitely degraded compared to the pronominal example.

In another example (adapted from Nunberg 1993), a teacher is discussing what his students' fathers do for a living. The teacher points out several children, including Nancy and Mary, and says (88).¹²

(88) He [gesture toward Nancy] is in real estate, and he [gesture toward Mary] is a banker.

The difference between deferred reference in pronouns and in demonstratives cannot be tested in Hindi or Marwari, which only have demonstratives. There are languages, though, which have correlatives as well as pronouns and demonstratives, such as Bangla. Ideally further research would look at one

12. For some speakers, (88) is degraded but (iii), in which the teacher is explaining what both parents do, is more acceptable.

(iii) They [gesture toward Nancy] are in real estate, and they [gesture toward Mary] are both bankers.

This example also highlights the same puzzle with regard to demonstratives. While (iii) is acceptable, (iv) was judged either entirely unacceptable or significantly degraded.

(iv) */# These parents [gesture toward Nancy] are in real estate, and those parents [gesture toward Mary] are both bankers.

of these languages to determine how the type of indexical would affect deferred reference in correlative constructions and where the indexical is a non-correlate. Unfortunately, neither one of these reasons for why correlative may not allow the index to be different from the interpretation account for examples like (82) and (84), which only became unacceptable when the index was overt.

Finally, the interpretation of demonstratives and the availability of deferred reference seems to depend on the interpretation of the null NP in the demonstrative phrase. Recall that, in Hindi and Marwari, the correlate phrase may be either a demonstrative-NP phrase or a bare demonstrative. Even when the demonstrative is bare, it is assumed that there is a null NP in the sort phrase position (see Section 3.3.4).

In the correlative construction, there seems to be a significant difference in felicity judgments depending on whether the NP sortal phrase is null or spelled out. The Hindi equivalent of (79) is significantly degraded if the NP_{MC} is deleted, as illustrated in (89).

(89)?? *imran* [*dzo* *posTar* *bhit* *per laT* *gaya*
 Imran which poster wall.M.SG.OBL on hanging go.LGT.M.SG
 hai] *vo* *kharidha*
 PRS.3.SG that buy.PFV.M.SG

'Imran bought, which poster is hanging on the wall, that.'

Despite these factors, it is still not clear why correlative constructions such as (84) are infelicitous even when it appears to have the same semantic contribution as a similar construction which does not have an overtly pronounced index. It appears that the spelling out of the index significantly reduces the flexibility of the relation R in demonstratives. Clearly, the relationship between the index and the interpretation is more complex than previously assumed. Correlatives, where the index is overt, may give further insight into the precise semantic contribution of these components and how they interact.

While there is certainly more to look at regarding the semantics of the demonstrative, the fact that the correlative construction – including both nominal and adverbial correlatives – shows deferred reference at all is important to understanding the relationship between the correlative clause and the demonstrative. Syntactically, that the correlative and the interpretation dis-

play deferred reference is evidence that the correlative is base-generated within the scope of R, therefore inside of the DemP rather than adjoined above it. This is also further evidence that the correlative clause is an argument of the demonstrative and acting as the index.

3.6 Conclusion

In this chapter, I showed that the correlative construction is an extension of the underlying structure of the demonstrative. The demonstrative phrase itself is made up of multiple components. The contribution of these components are apparent in cases of deferred reference in which the index of the demonstrative is not the same entity as the one contributed by DemP. The demonstrative morpheme (in English, *this* or *that*) takes three arguments: the index *i*, a relation R, and an NP restrictor. The structure of the demonstrative phrase is (90; see Section 3.2).

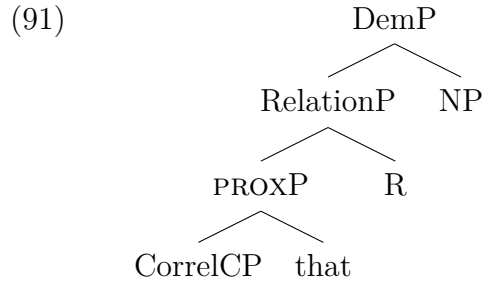
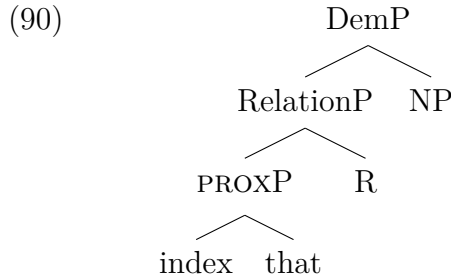

I propose that the Hindi and Marwari correlative is an overt pronunciation of the index component of the demonstrative phrase (Section 3.3). The correlative-demonstrative constituent, therefore, is really just a demonstrative phrase with the structure (91), above (Section 3.3.1). The correlative enters the syntax as the first argument of the demonstrative morpheme.

The lexical entry of each of the components of the demonstrative phrase is the same whether the index is spelled out overtly or not. The meaning assumed for these components are repeated in (92), below.

- (92) a. $\llbracket \text{that} \rrbracket^{h,a,t} = \lambda x_{\langle e \rangle} . \lambda f_{\langle e, \langle se, st \rangle \rangle} . \lambda g_{\langle et \rangle} . \lambda e_{\langle s \rangle} . \iota z (f(x)(\lambda e'_{\langle s \rangle} . z))(e) = 1$
 $\wedge g(z) = 1 \wedge \text{DIST}(x,a,t)$
- b. $\llbracket \text{this} \rrbracket^{h,a,t} = \lambda x_{\langle e \rangle} . \lambda f_{\langle e, \langle se, st \rangle \rangle} . \lambda g_{\langle et \rangle} . \lambda e_{\langle s \rangle} . \iota z (f(x)(\lambda e'_{\langle s \rangle} . z))(e) = 1$
 $\wedge g(z) = 1 \wedge \text{PROX}(x,a,t)$

- c. In cases where R is an identity relation,
 $[[R]] = \lambda a. \lambda b_{\langle s, e \rangle}. \lambda e_{\langle s \rangle}. b(e) = a$

Under this approach, a correlative-demonstrative phrase such as (93) has the structure (94).

- (93) $[\text{DemP } [\text{CorrelCP } \widehat{d}3o \text{ kitab sera ne lik}^hi \text{ he }] \text{ vo }]$ [Dem
 which book Sera ERG write.PFV.F.SG PRS.3.SG
 that
 'which book Sera wrote, that' [HINDI]

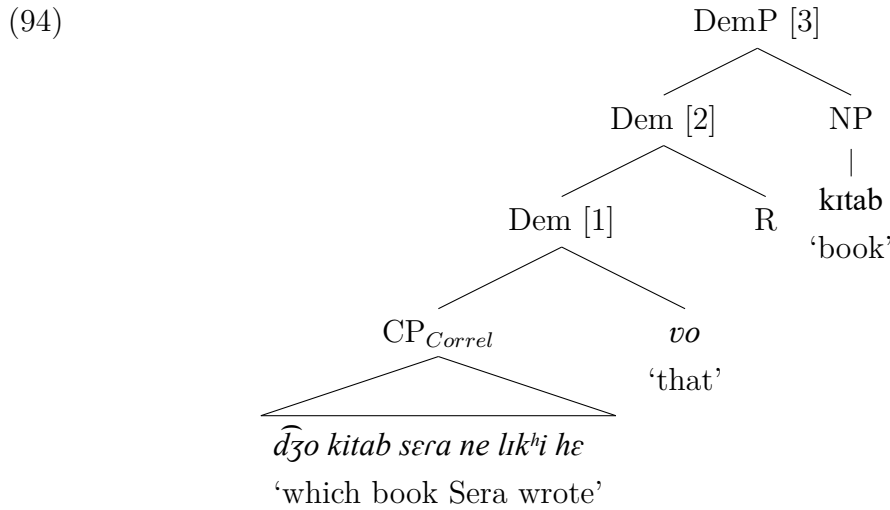

The semantic contribution of the demonstrative phrase in (93) is (95).

- (95) $\lambda e. \iota z (z = \iota x (\exists e'. x \text{ is the book which Sera wrote in } e) \text{ in } e \wedge z \text{ is a book} \wedge \text{DIST}(\iota x (\exists e. x \text{ is the book which Sera wrote in } e, a, t)))$

Dual headed correlatives in which the NP_{Cor} differs from the NP_{MC} are a natural consequence of this analysis as the correlative CP is generated independently the NP of the demonstrative phrase (Section 3.3.2).

The same analysis can be extended to pronominal correlates, as well (Section 3.3.3). The components of the pronoun include *i*, R, and a pronominal head such as *it*. The structure of the pronominal differs slightly from the demonstrative, as shown in (96).

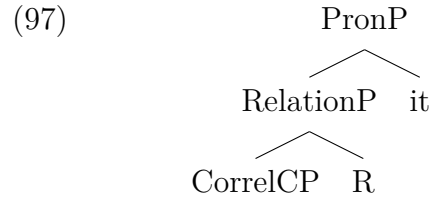
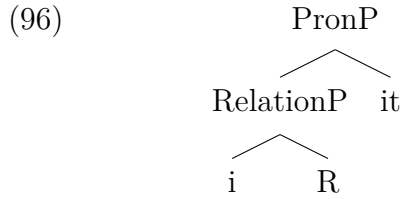

As with the demonstrative correlate, the correlative may enter the syntax as an overt pronunciation of the index of the pronoun. The correlative-pronominal constituent, then, has the structure in (97).

This analysis makes some predictions about the nature of the correlative construction (Section 3.4). For instance, proximal demonstratives should be able to act correlates, as well. This proves to be the case. Second, it should also be possible for the correlative to enter the syntax as an argument of first and second person pronouns. While this is possible for first person plural pronouns to act as the correlate in Marwari, speaker judgments varied as to whether first person singular pronouns or second person pronouns are able to act as correlates. It is likely that the index of first and second person pronouns is more rigid than the index of third person pronouns, and this is what restricts these pronouns from acting as correlates. The fact that correlatives show deferred reference – albeit, in a somewhat limited fashion – is further evidence that the correlative is the overtly pronounced index of the demonstrative.

While I have focussed on Hindi and Marwari in this discussion, this analysis may be extended to other languages with the same type of construction, including those outside of MIA.

Chapters 2 and 3 have so far been focussed on nominal correlatives which relate to arguments. In Chapters 4 and 5, I turn my attention to the adverbial correlative construction which involves correlatives headed by adverbial relative phrases such as *āṣahā* ‘where’ and *āṣāb* ‘when’ (Hindi). In Chapter 4, I show that adverbial correlatives are a true correlative construction with the same syntactic features as the nominal correlative. I also argue that adverbial correlatives are not, in fact, adverbial but denote individuals of type e.

In Chapter 5, I extend the analysis presented in this chapter to the adverbial correlative construction, arguing that they, too, are overtly pronounced indices.

Chapter 4

The adverbial correlative

4.1 The purpose and direction of this chapter

In the previous chapter, I summarized the syntactic features of the correlative construction, with particular focus on the correlative in Modern Indo-Aryan (MIA). I discussed previous analyses of the correlative such as Dayal (1996) and Bhatt (2003), and argued that, while these are significant contributions to understanding the correlative construction, they cannot sufficiently account for the relationship between the correlative clause and the demonstrative correlate. In Chapter 3, I argued that, rather than entering the syntax as an adjunct, the correlative clause is base-generated as an argument of the demonstrative phrase. More specifically, the correlative is an overt pronunciation of the index of the demonstrative.

Most papers on the correlative construction, both descriptive and analytic, focus on correlatives in which the relativized phrase is a nominal. These are correlatives like (98), where the relative phrase is headed by Hindi $\widehat{d}\widehat{z}o$, or similar examples in Marwari where the relativizing pronoun is $\widehat{d}\widehat{z}\widehat{a}ko$, where $\widehat{d}\widehat{z}o$ and $\widehat{d}\widehat{z}\widehat{a}ko$ may be translated as ‘who, which, or that’.

- (98) [_{CorrelCP} $\widehat{d}\widehat{z}o$ $l\grave{a}rki$ $k^h\acute{e}ri$ $h\epsilon$] vo $l\grave{a}mbi$
which girl.F.SG standing.F.SG be.PRS.3.SG that tall.F.SG
 $h\epsilon$
be.PRS.3.SG

‘Which girl is standing, that/she is tall’ (from Dayal 1996, p. 152) [HINDI]

As the nominal wh_{RC} , $\widehat{d}\widehat{z}o$ and $\widehat{d}\widehat{z}\widehat{a}ko$ are related, semantically if not morphologically, to the Hindi and Marwari nominal interrogatives *kya* and *kayi* ‘what?’.

In addition to these nominal correlatives, there is another variety of correlative which I will call the *adverbial correlative*. These are correlatives which involve a relativized adverbial and which often relate to an adverbial correlate in the main clause. An adverbial correlative, then, is a correlative clause which is headed by an adverbial relativizing *wh* (wh_{RC}), which is in turn related to adverbial interrogative *wh* (wh_Q). For example, in (99a), the interrogative is headed by the wh_Q $k\widehat{a}t^h e$ ‘where?’ (in bold). In (99b), the correlative clause is headed by the relativized *wh*-element $\widehat{d}\widehat{z}\widehat{a}t^h e$ ‘where_{RC}’ (also in bold). The correlative clause then relates to the adverbial correlate $b^h\widehat{a}t e$ ‘there.’

- (99) a. vo $\widehat{t}^h\widehat{o}ro$ **$k\widehat{a}t^h e$** $\widehat{d}\widehat{z}\widehat{a}v e$
 that boy.M.SG where_? go.IMPV.PRS.M.SG
 ‘Where does that boy go?’ [MARWARI]
- b. [_{CorrelCP} **$\widehat{d}\widehat{z}\widehat{a}t^h e$** $b^h\widehat{i}t$ $r\widehat{e}v e$] $\widehat{t}^h\widehat{o}ro$
 where_{RC} crowd.F stay.IMPV.PRS.3.SG boy.M.SG
 $b^h\widehat{a}t e$ $\widehat{d}\widehat{z}\widehat{a}v e$
 there go.IMPV.PRS.M.SG
 ‘Where a crowd gathers, (the) boy always goes there.’ [MARWARI]

While overlooked in most discussions of the correlative construction, adverbial correlatives can be found throughout MIA. Examples can be found in many description grammars (cf. Kachru 2006; Koul 2008), although they are often classified as adverbial or adverbial clauses rather than as correlatives.¹

This is not to say that all adverbials in MIA languages are adverbial correlatives. There are several types of adverbial clauses or phrases which are quite different from correlatives and which will not be included in this discussion. One example of this is the participial adverbial construction as shown in (100).

1. Because less formal work has been done on adjunct correlatives, there are not as many examples of these in the literature. In this chapter, I will focus largely on Hindi and Marwari data from my own fieldwork, with examples from other languages where they are available, but the analysis presented here will apply across Indo-European languages. Fieldwork focused on Delhi and Uttar Pradesh varieties of Hindi-Urdu and Jodhpur variety of Marwari. Examples from other texts are as noted.

- (100) *l̥ʌrke gʰumte hue idʰər a nikle*
 boys.M.PL stroll.IMPV PTPL.OBL this-way come emerge.PFV.M.PL
 'The boys came this way as they were strolling.' (*from* Kachru 2006, p. 98)
 [HINDI]

MIA languages also often use reduplication to construct an adverbial phrase, as seen in (101).

- (101) *vo [AdvP pəɽʰte-pəɽʰte] so gəjə*
 that read.IMPV-REDUP sleep go.LGT.PFV.M.SG
 'He fell asleep while reading.' (*from* Kachru 2006, p. 98) [HINDI]

The Hindi conjunctive participle *kər* can also give a clause an adverbial interpretation, as in (102).

- (102) *vo [ConjP dəftər se a kər] kəpɽe bədəl*
 that office.M.SG from come KAR clothes.M.PL change
rəhə he
 PROG.M.SG PRS.3.SG
 'He is changing his clothes after returning from the office.'
Lit: 'Having returned from the office, he is changing clothes'.
 (*from* Kachru 2006, p. 100) [HINDI]

Very generally, I will not be looking at these types of adverbial constructions but will restrict the discussion of adverbial correlatives to those finite clauses headed by a adverbial *wh_{RC}* and which precede the correlate in linear order and which relate to it semantically. The defining features of the adverbial relative will be discussed in further detail in the next section.

My purpose in discussing the adverbial relative is three-fold. First, because the adverbial relative is so little discussed in the literature, there are very few examples available compared to the nominal relative. In order to have a generalized account of the correlative construction, it is important to consider the adverbial relative, as well. Having introduced the adverbial relative (Section 4.2), I present new data from Hindi and Marwari confirming that the adverbial relative has the same syntactic features as the nominal relative and is, therefore, a true correlative construction (Section

4.3). Further, I show that the adverbial correlative does not behave like other adverbial constructions but, in fact, acts like a nominal phrase.

In the next chapter, I look in depth at the underlying syntactic construction and semantic contribution of the adverbial correlative construction and show that, like the nominal correlative construction, the adverbial correlative is an overt pronunciation of the index of its correlate.

There is one particular variety of adverbial correlative which has been discussed extensively, and that is the degree correlative or clausal comparative. While I do not go into an in depth discussion of the degree correlative, I will show that the degree correlative is not a distinct construction from the other adverbial correlatives but has the same syntactic features and underlying structure.

4.2 The adverbial correlative construction

Like the nominal correlative, the adverbial correlative construction is made up of an correlative clause which relates to a correlate in the main clause. Instead of being headed by a nominal wh_{RC} -phrase, the adverbial correlative is headed by a wh_{RC} -phrase related to an adverbial (or adjunct) wh_Q . The adverbial correlative is then related to a correlate in the main clause, where the correlate is often an adverbial demonstrative. For example, in (103) below, the correlative clause $\widehat{d}\bar{z}\bar{a}b\ meri\ umr\ p\bar{o}ndra\ sal\ ki\ t^hi$ ‘when I was fifteen years old’ includes the wh_{RC} $\widehat{d}\bar{z}\bar{a}b$ ‘when’. The correlative itself relates to the main clause via the temporal correlate $t\bar{a}d$ ‘then’.

(103) Temporal Correlative Construction

- a. [_{CorrelCP} $\widehat{d}\bar{z}\bar{a}b\ meri\ umr\ p\bar{o}ndra\ sal\ ki$
 when_{RC} my.F age.F fifteen.OBL year.OBL of
 t^hi] $t\bar{a}b\ m\bar{e}\ ne\ ga\bar{d}i\ i^h\bar{a}la-na$
 be.PST.F.SG then I ERG car.F.SG drive/move-INF.M.SG
 sik^ha t^ha
 learn.PFV.M.SG PST.3.M.SG

‘I learned to drive a car when I was fifteen years old.’

Lit.: ‘When I was fifteen years old, then (at that time) I learned to drive a car.’

[HINDI]

- b. [CorrelCP *ḍāḍe mari umr pondra sal ũ heti*]
 when_{RC} my.F age fifteen.OBL year.OBL SRC be.PST.F.SG
tad mē gaḍi ṭfelavā-ṇi sik^{hi}
 then I car.F.SG drive/move-INF.F.SG learn.PFV.M.SG

Lit.: 'When I was fifteen years old, then (at that time) I learned to drive a car.' [KM MAR.]

Similarly, a locative correlative construction such as (104) involves a locative correlative *ḍāḍā mē rehta hū* 'where I live', headed by the adverbial *wh_{RC} ḍāḍā* 'where'. The correlative then relates to the correlate *vahā* 'there' in the main clause.

(104) Locative Correlative Construction

- [CorrelCP *ḍāḍā mē rehta hū*] *vahā koi*
 where I stay.IMPV.3.M.SG PRS.1.SG there anyone
angrezi nahī ḍāḍanta
 English not know.IMPV.3.M.SG PRS

'Where I live, there no one knows English.' (*adapted from* Snell and Weightman 2005) [HINDI]

Adverbial correlatives do not always relate to times and locations. There are Marwari and Hindi adverbial relative phrases related to all of the adverbial *wh_{QS}* except for *kjū* 'why'. Manner adverbials such as (105), for instance, describe the manner or way in which something is done.² In this case, Usha's mother is teaching her to make chapatis or flat bread, and Usha is making them in the same way.

2. The relative pronoun *ḍāḍesa* 'how, what kind', particularly used in the phrase *ek ḍāḍesa* (literally 'one how'), can also be used to mean 'the same as'. This is a specialized usage and will not be included in the current analysis.

- (i) *dōṇō ek ḍāḍesa dik^haj de rāhe t^e*
 both one how/kind look give PROG.M.PL PST.M.PL

'They both looked just the same.' [HINDI]

(105) Manner correlative construction

[_{CorrelCP} *uʃa ki mā ḍʒese tʃʰəpati bənati*
 Usha of.F.SG mother how.manner chapati make.IMPV.F.SG
hɛ] uʃa vɛsa sikʰ-na tʃʰahəti hɛ
 PRS.3.SG Usha that.way learn-INF want.IMPV.F.SG PRS.3.SG

'Usha wants to learn to make chapatis the same way that her mother makes chapatis.'

Lit.: 'How Usha's mother makes chapatis, Usha wants to learn to make chapatis (flat bread) that way.' [HINDI]

Note that the *kind-wh_{RC}* is overtly similar to the manner *wh_{RC}* in Hindi, and they can be easily confused. While *ḍʒese* means 'how, what manner', the *wh_{RC}* *ḍʒesa* means 'what kind'. Not only is their meaning distinct, but only *ḍʒesa* 'what kind' shows number and noun class agreement, such as we see in (106).

(106) Kind correlative construction

[_{CorrelCP} *ḍʒesi dʰal həmɛ tʃʰahije] vɛsi jahã*
 what.kind.F.PL lentil I.DAT need that.kind.F.SG here
nuhĩ multi
 NEG meet/find.IMPV.F

'The kind of lentils I need, we will not find that kind here.' [HINDI]

The kind and manner *wh_{RC}*-phrases are more distinct in Marwari, where *ḍʒedo* means 'what kind' and *ḍʒjũ* means 'how, what manner'.³ This contrast can be seen in the following examples. (107) is appropriate in a situation where the speaker's brother Anu always does things the same way he does.

(107) Manner correlative construction

[_{CorrelCP} *ḍʒjũ mɛ sirt pʰeru] jũ*
 how.manner I shirt.M.SG put.on.SUBJ.1S that.manner
ənuʋ ʔi sirt pardave
 Anup EMPH shirt.M.SG put.on.IMPV.3

'How I put on my shirt, Anup also puts on his shirt that way.' [MARWARI]

3. Gusain (2004)'s Marwari g mmar has examples with the *wh_{RC}* *ḍʒija* 'what kind' and the correlate *bija* 'that kind'. None of the varieties of Marwari that I looked at had either *ḍʒiya* or *bija*.

While Marwari, Hindi, and other MIA languages do not have a correlative pronoun related to the interrogative *kjũ* ‘why’, other languages do.⁵ Polish not only has *why*-correlatives but two types of them: the reason-why (whyR) correlative and the purpose-why (whyP) correlative (Citko 2009, p. 54).

- (110) a. [CorrelCP *Dlaczego Maria zrezygnowała*] *dlatego Jan też*
 whyR Maria resign.P.3.SG DEM Jan also
powinien zrezygnować
 should resign.INF
 ‘Jan should resign for the same reason Maria resigned.’
 (from Citko 2009, p. 54) [POLISH]
- b. [CorrelCP *Po co Jan wyszedł*] *po to samo Maria też*
 whyP Jan leave.P.3.SG DEM same Maria also
wyszła
 leave.P.3.SG
 ‘Jan left for the same reason/purpose Maria left.’
 (from Citko 2009, p. 54) [POLISH]

In Section 4.2, I show that while adverbial and nominal correlatives seem to play a distinct role in the syntax, they are syntactically the same construction.

5. It is possible to construct a *why-that way* style correlative construction in Hindi and Marwari similar to the Polish examples sentence, but it involves a headed nominal relative phrase and a nominal demonstrative in the main clause rather than an adverbial *wh_{RC}*. *āzāke kārəṇa* and *āzīs kārəṇ* ‘which reason’ in Marwari and Hindi, respectively, can be used to mean both ‘for what reason’ and ‘for what purpose’.

- (iii) a. [CorrelCP *molu āzāke kārəṇa apri motosajkāl hawaḷ kari*]
 Molu which reason own motorcycle.F.SG repair do.PFV.F.SG
gita ʔi apri gaḍi hawaḷ karaji
 Gita also own vehicle.F.SG repair do.CAUSE.PFV.F.SG
 ‘The reason Molu repaired his motorcycle is the reason why Geeta had her vehicle repaired as well.’
Lit.: ‘For which reason Molu repaired his motorcycle, Geeta had her own vehicle repaired for that reason.’ [MARWARI]
- b. *āzīs kārəṇ namita ne istifa de dija us-si*
 which.OBL reason Namita ERG resignation.M.SG give give.LGT.PFV.M.SG Geetika
kārəṇ gitika ko bʰi istifa dena īʃahije
 DAT also resignation.M.SG give.INF need
 ‘Namita resigned, and Geetika needs to resign for the same reason.’
Lit.: ‘For which reason Namita resigned, Geetika also needs to resign for that reason.’ [HINDI]

Their only difference is that the adverbial correlative-correlate constituent enters the syntax as an adjunct while the nominal correlative-correlate acts as an argument.

4.3 Adverbial correlatives are true correlatives

Before discussing the adverbial correlative in depth, it is important to show that these are indeed correlative constructions. There are a few reasons to spend some time making this explicit. The first reason is that these constructions have been overlooked in most discussions of the correlative, whether because they are assumed to be something else or because the focus was the nominal correlative. Many descriptive works (e.g., Grierson 1908, Kachru 2006, and Koul 2008 for Hindi; Dhongde and Wali 2009 for Marathi) group these constructions together with adverbials/adverbial clauses headed by the adverbials *kjōnki* ‘because’ and *māgar* ‘even though’ and separately from the correlative construction. In some cases, this is because the author assumes that the nominal correlative is derived from the postnominal, externally headed relative clause (e.g., Kachru 1973, 2006). Other analyses, such as Mahajan (2000), do not mention adverbial correlatives and can only apply to nominal correlatives. Under these analyses, the nominal correlative is assumed to be the same construction as postnominal relative clauses. While other linguists working on Modern Indo-Aryan languages do consider adverbial correlatives to be true correlative constructions (Rajesh Bhatt, Veneeta Dayal, p.c.), very little formal work has been done on them. Further, Dayal (1996)’s analysis of nominal correlatives has not been extended to adverbial correlatives.

Another reason to look at the adverbial correlative constructions more closely is that, while adverbial correlatives are very similar to the nominal correlative, there are some interesting differences which will tell us both about the correlative construction itself and about the way that adverbials are constructed in general.

In Chapter 2, the correlative construction was defined as having the following syntactic features.

(111) Syntactic features of a correlative construction:

- (a) There must be an appropriate correlate, either a demonstrative or a pronominal, in the main clause (*the demonstrative requirement*)

- (b) Are base-generated to the left of the associated phrase, as part of the same constituent, and may then optionally be fronted.
- (c) Headed by a relative pronoun (wh_{RC}), which may remain in-situ.
- (d) The relativized element may appear in both the relative clause and the correlative (*headedness*), and both the wh_{RC} and the correlate may be case-marked independently.
- (e) Correlatives license multi-headed relative clauses.

In this section, I will show that, while adverbial correlatives enter the syntax as adjuncts, they still display these same syntactic features.

4.3.1 The demonstrative requirement

One of the primary defining features of the correlative construction is a relativized clause which relates to a demonstrative or other appropriate indexical in the main clause. Recall that Chapter 2, following de Vries (2005), showed that the correlate does not necessarily have to be a demonstrative. Bangla, for instance, allows pronominal correlates. Building on Dayal (1996), I therefore proposed the Revised Demonstrative Requirement in (112, repeated from Chapter 2, example 30).

(112) *Revised Demonstrative Requirement*

A correlative clause must be associated with an appropriate correlate in the main clause, where that correlate may be a demonstrative phrase, pronominal, or other indexical.

In the case of adverbial correlative constructions, the correlate may be an adverbial indexical such as *tab* ‘then’ and *vahā* ‘there’ in Hindi or *tad* ‘then’ and *vathē* ‘there’ in Marwari.⁶

If the correlate is absent, for most Hindi speakers, the sentence is ungrammatical.⁷ This is true for most types of adverbial correlatives, including loca-

6. In Hindi, the correlate with corresponds to temporal correlatives may optionally be either *tāb* ‘then’ or *to* ‘so, then’.

7. Rajesh Bhatt (p.c.) notes that (113) is grammatical for him with or without a demonstrative. In the varieties I looked at, all of my consultants required the demonstrative.

(2008) and Gusain (2004). It is common in Hindi for a temporal correlative to not have a corresponding correlate, as in (114).

- (114) [*d̄ʒəb ap us-se dhjan se dekʰeŋge*]
 when you.HON that.OBL-ACC attention with watch.FUT.2.HON
ap (təb) gʰend pəkədeŋge
 you.HON then ball catch.FUT.2.HON
 'When you watch it, you will catch the ball (then).' [HINDI]

Examples of this occur not only in elicitation but also appear in natural speech, as in this example from a story told by my Hindi-Urdu consultant.⁹

- (115) *vo t̄ʃʰuʰe soʃʰte tʰe* [*d̄ʒəb bil:i*
 that/those mouse think.IMPFV.M.PL PST.M.PL when cat
ati he] *həm nuhĩ d̄ʒan patʰe*
 come.IMPFV.F.SG PRS.3.SG we NEG know manage/able.IMPFV.F.PL
ki bil:i a rəhi he
 COMP cat come PROG.F.SG PRS.3.SG

'They thought: When (the) cat comes, we cannot know that the cat is coming.'

[HINDI]

There are two possibilities for why the temporal correlative does not require a correlate in the main clause. First, it is possible that the correlative was base-generated at the correlate but the correlate then underwent *pro*-drop and is simply unpronounced. The second possibility is that the temporal clause is actually entering the syntax directly as a free relative. In this case, this is not actually a correlative construction. Regardless, the temporal correlative is able to enter the syntax in a correlative construction (with an overt) correlate, so the possibility of a construction without an overt correlate does not affect the analysis presented here. In either case, this is not a true violation of the demonstrative requirement, then, as either the demonstrative is required and may undergo *pro*-drop or this is not a correlative construction. I revisit the temporal correlative construction in Section 4.4.

9. In many Hindi varieties, the demonstrative *vo* 'that' no longer has a number feature. In Hafiz's variety (Nizamuddin, Delhi) of Hindi-Urdu, *vo* 'that', typically singular, is also sometimes used for the plural. The fact that *vo* here is plural is reflected in the verb agreement.

4.3.2 The correlative-correlate constituent

Like the nominal correlative, adverbial correlatives also largely occur at the left periphery in both spoken and written language (see Chapter 2, Section 2.2.2.3 and Section 2.3.2). But, they may also be pronounced immediately preceding the adverbial demonstrative itself, within the main clause. This is true for all varieties of adverbial correlative in both Hindi and Marwari, including locative and degree correlatives as shown in (116).

- (116) a. *mē* [_{CorrelCP} *ḍ̥ḍ̥atʰe tʰe tʰa-ro tʰelo*
 I where you.HON you.OBLof.M.SG bag.M.SG
rakʰiyo] [_{DemP} *utʰe*] *mari iʃʰabiyā rakʰi*
 keep.PFV.M.SG there my.F.PL key.F.PL keep.PFV.F.PL
 'I put my keys where you kept your bag, there.' [MARWARI]
- b. *tʰe un tʰela maj* [_{CorrelCP} *ḍ̥ḍ̥it:i səkər mē*
 you that.OBL bag.OBL.M.SG in how.much sugar I
m tʰela maj gʰal [i]
 this.OBL bag.OBL.M.SG in put take.LGT.PFV.F.SG
 [_{DemP} *ut:o id̥ḍ̥*] *gʰal ḍ̥o*
 that.much EMPH put give.LGT.IMP/SUBJ
 'You should put the same amount sugar into that bag as I put into this bag.'
Lit.: 'You should put into that bag, how much sugar I put into this bag, that much.' [MARWARI]

Just as Bhatt (2003) showed for the nominal correlative (see Chapter 2, Section 2.3.2), binding effects also show that the adverbial correlative is base-generated below the subject.¹⁰ For example, if a proper name is in the locative correlate clause, it cannot be co-indexed with a demonstrative in the subject position of the main clause. Thus, the following example (117) cannot mean that Meena bought her new sari where she, Meena, works.

10. See Chapter 8 for more details on how the binding effects in these examples were tested.

- (117) [*d̪ʒət^he mina_i kam kare*] *ba*_i naji sari*
 where Meena work do.IMP.FV.3.SG that.F.SG new sari
bijaũ re vaste ut^he k^haridi
 wedding.OBL for there buy.PFV.F.SG

Intended: 'Where Meena_i works, she (Meena) bought a new sari for the wedding (from) there.' [MARWARI]

The same binding effect restrictions were found for manner correlatives in Marwari as well. That is, a proper name in the manner correlative, even if it is fronted, cannot bind a demonstrative in the subject position of the main clause.

The binding effects show that the adverbial correlative clause is base-generated sentence internally, adjacent to the correlate itself.

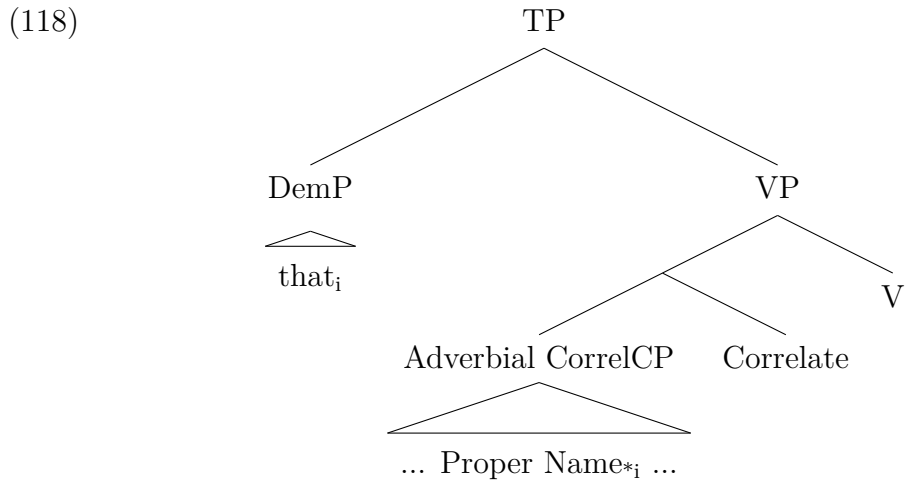

Because the subject demonstrative scopes over CorrelCP, this leads to a violation of Condition C. If the correlative were adjoined to IP, there would be no violation of Condition C and (117) would be grammatical.

Interestingly, even though they do not relate to the main clause through a correlate, the same binding effects seem to hold for the temporal relative as well, even where it does not have a correlate in the main clause. Given a situation where Aashish laughed at Bhomlii when she told him that she likes him, the following sentence is not felicitous.

- (119) [$\widehat{d}\widehat{z}\widehat{a}d$ *b^homli kejo ke un-ne* *afif_i daji*
 when Bhomlii said that that.OBL.SG-DAT Ashish like.PFV.F.SG
he] *bo*_i un mat^he hāsijo*
 PRS.3.SG that.M.SG that.OBL.SG on laugh.PFV.M.SG
 ‘When Bhomlii said she liked Aashish_i, he*_i laughed at her.’ [MARWARI]

The adverbial correlative is also subject to the Coordinate Structure Constraint (CSC), just as the nominal correlative is. It is possible in both Hindi and Marwari to coordinate two correlative-correlate pairs, as illustrated in (120).

- (120) # *ram* [[_{CorrelCP1} $\widehat{d}\widehat{z}\widehat{a}t^he$ $\widehat{d}\widehat{z}\widehat{a}w\widehat{a}h\widehat{a}r\widehat{l}\widehat{a}l$ *nehru*
 Raam where Jawaharlal Nehru live.IMPFV.M.SG
revata tha]
 PST.M.SG there
ut^he ar [_{CorrelCP2} $\widehat{d}\widehat{z}\widehat{a}t^he$ *indira gand^hi* *revati thi*]
 and where Indira Gandhi live.IMPFV.F.SG PST.3.SG there
ut^he] *giyo*
 go.PFV.3.M.SG

‘Raam went where Jawaharlal Nehru lived and where Indira Gandhi lived.’
Lit.: ‘Raam went where Jawaharlal Nehru lived, there, and where Indira Gandhi lived, there.’ [OSIAN MAR.]

As with the nominal correlative, Marwari allows the correlative associated with the first demonstrative in a coordinated structure can be fronted.¹¹

- (121) [_{CorrelCP1} $\widehat{d}\widehat{z}\widehat{a}t^he$ $\widehat{d}\widehat{z}\widehat{a}w\widehat{a}h\widehat{a}r\widehat{l}\widehat{a}l$ *nehru revata* *tha*]
 where Jawaharlal Nehru live.IMPFV.M.SG PST.M.SG
ram [*t_i ut^he ar* [_{CorrelCP2} $\widehat{d}\widehat{z}\widehat{a}t^he$ *indira gand^hi* *revati*
 Raam there and where Indira Gandhi live.IMPFV.F.SG there
thi] *ut^he*] *giyo*
 go.PST.3.M.SG

‘Where Jawaharlal Nehru lived, Raam went there, and where Indira Gandhi lived, there.’ [MARWARI]

11. Even though Indira Gandhi is Jawaharlal Nehru’s daughter, they each kept different residences during their respective tenures as prime minister of India.

While the first correlative is able to front out of the coordinated structure in Marwari, the fronting of the second correlative out of the coordinate structure is prohibited, as illustrated in (122).

- (122) * [CorrelCP2 $\widehat{d\bar{z}\bar{a}t^h e}$ *indira gand^{hi} revāti* *t^{hi}*]_i *ram*
 where Indira Gandhi live.IMPFV.F.SG PST.3.SG Raam
 [[CorrelCP1 $\widehat{d\bar{z}\bar{a}t^h e}$ $\widehat{d\bar{z}\bar{a}v\bar{a}harl\bar{a}l}$ *nehru revāta* *t^{ha}*]
 where Jawaharlal Nehru live.IMPFV.M.SG PST.M.SG
ut^{h e} ər t_i ut^{h e}] gijo
 there and there go.PFV.3.M.SG

'Where Indira Gandhi lived, Raam went where Jawaharlal Nehru lived, there and there.'
 [OSIAN MAR.]

The fronting of the second correlative out of the coordinate structure is prohibited for adverbial correlatives, as well.

- (123) * [CorrelCP2 $\widehat{d\bar{z}\bar{a}t^h e}$ *indira gand^{hi} revāti* *t^{hi}*]_i *ram*
 where Indira Gandhi live.IMPFV.F.SG PST.3.SG
 [[CorrelCP1 $\widehat{d\bar{z}\bar{a}t^h e}$ $\widehat{d\bar{z}\bar{a}v\bar{a}harl\bar{a}l}$ *nehru revāta t^{ha}*]
 Raam where Jawaharlal Nehru live.IMPFV.M.SG
ut^{h e} ər t_i ut^{h e}] gijo
 PST.M.SG there and there

'Where Indira Gandhi lived, Raam went where Jawaharlal Nehru lived, there and there.'
 [OSIAN MAR.]

The fact that the adverbial correlative can be pronounced within the main clause preceding the demonstrative and the binding effects exhibited are good evidence that the adverbial correlative clause is base-generated inside of the main clause rather than at the periphery. That an adverbial correlative clause is restricted from moving out of a coordinate structure shows that the adverbial correlative and the correlate are base-generated as part of the same constituent.

4.3.3 The adverbial wh_{RC} may also remain in-situ

Like nominal correlatives constructions, the adverbial relative clause is headed by a (non-optional) relative pronoun or relativizing wh (wh_{RC}).¹²

This is possible for all varieties of adverbial relative in both Hindi and Marwari. Examples of an in-situ manner wh_{RC} and degree wh_{RC} are included below. The locative, temporal, and kind wh_{RC} -elements were able to remain in-situ, as well, in both Hindi and Marwari.

- (124) a. [*uʃa ki mā ḍʒese tʃapati bənati he*]
 Usha of.FEM mother how chapati make.IMP.FV.F.SG PRS.3.SG
uʃa vese sik^h-na tʃ^hahati he
 Usha that.way learn-INF want.IMP.FV.F.SG PRS.3.SG

'Usha wants to learn to make chapatis how her mother makes them.'

Lit.: 'How Usha's mother makes chapatis, Usha wants to learn to cook that way.'

[HINDI]

- b. [*siŋg^h re kəne ḍʒita tʃəkər he*]
 Singh of.OBL near how.many servant be.PRS.3.SG
uŋə ï gopal re kəne ḍʒada tʃəkər he
 those.OBL SRC Gopal of.OBL near more servant be.PRS.3.SG

'Mr. Singh has more servants than Mr. Gopal does.'

Lit.: 'How many servants Mr. Singh has, Mr. Gopal has more than that.'

[KM MAR.]

It is not only Hindi and Marwari correlatives which allow the wh_{RC} to remain in-situ, but the adverbial wh_{RC} -phrase may remain in-situ across MIA.

- (125) a. [*ti ḍʒēhvā jete*] *tēvha to gato*
 she when comes at.that.time he comes

'When she comes, he comes at that time.' (*from* Dhongde and Wali 2009, p. 58)

[MARATHI]

12. It has been reported that Gujarati and Marathi sometimes allow the relative pronoun in a nominal correlative to be dropped, either through pro-drop or some other mechanism (Masica 1993, p. 413, citing Lambert 1971, p. 128, and Berntsen and Nimbkar 1975, p. 146, respectively). No data on whether this is possible in adverbial correlatives is available.

- b. [*tara dʒɔkʰon tʃole dʒabe*] *tɔkʰon amra aʃbo*
 they when away go then we come.FUT

'We'll come when they go away.' (from Masica 2006:415, citing

Page 1934:167)

[BANGLA]

Chapter 6, Section 6.3.3 discusses whether the in-situ relative phrase is interpreted in-situ or raises to LF for interpretation.

4.3.4 Headedness and case marking

One of the features of the nominal correlative construction (Chapter 2, Section 2.2.2.2) is that the relative phrase and the correlate phrase may both include an independently generated noun phrase. Dayal (1996) refers to this overt appearance of a noun phrase as *headedness*. Using the term descriptively, most adverbial wh_{RC} s will not be headed as they cannot include an NP component. But, there are two adverbial phrases which do have an NP component, the kind adverbial and the degree phrase.

Like the nominal correlate, it is possible for both the kind wh_{RC} -phrase and correlate phrase to include an NP. They may alternatively remain bare.

- (126) [*CorrelCP dʒɛri dres radʒəstʰani lugaji pʰere*]
 what.kind dress Rajasthani women put.on.IMPFV.PRS.3.SG
mẽ ʔi veʀi dres karidə-ŋi tʃʰaʔu
 I EMPH that.kind dress buy-INF.3.F.SG want.1.SG

'I want to buy an outfit like the ones that Rajasthani women wear.'

Lit.: 'What kind of clothes Rajasthani women wear, I want to buy that kind of clothes.'

[KM MAR.]

It is also possible for both the wh_{RC} -phrase and the correlate phrase to include two different NPs, indicating that the NP in the wh_{RC} -phrase is not a copy of the NP in the correlative phrase but is independently generated.

- (127) [*d̥ʒeɾi biriyāni hajd̥arvad mē mile*]
 what.kind biryani Hyderabad in meet.IMPFV.3.SG
ramnarajān veɾu həvad kʰava-ŋi t̪ʃave
 Ramnarayan that.kind delicacy eat-INF.F.SG want.IMPFV.PRS.3.SG
- ‘What kind of biryani one finds in Hyderabad, Ramnarayan wants to eat that kind of delicacy.’ [MARWARI]

An equative degree construction such as (128) may also involve both a degree *wh*_{RC}-phrase and a degree correlate, both of which have an overt NP. Like the nominal correlative, the NP in either phrase may be a null element.¹³

- (128) *mohan* [_{CorrelCP} *sima d̥ʒita l̥d̥u b̥anaya*]
 Mohan Sima how.many ladoos.M.PL make.PFV.M.PL
uta (l̥d̥u) id̥ʒ kʰaya
 that.many ladoos.M.PL EMPH ate.PFV.M.PL
- ‘Mohan ate as many ladoos as Sima made.’
Lit.: ‘Mohan, how many ladoos Sima made, ate that many (ladoos).’ [KM MAR.]

This indicates that, just as was seen with nominal correlatives, the NP ‘heads’ of the *wh*_{RC}-phrase and the correlate phrase are independently generated and are not copies of one another or cases of multiple spell-out.

It is also possible for both phrases to be case-marked independently, although this is quite restricted, apparently due to semantic restraints. In order to test this, I looked at the temporal and the locative *wh*_{RC}-phrase and correlate phrase. The temporal adverbial is the most likely to be case-marked in Marwari. The locative pronoun may also be case-marked, but less frequently because, in Marwari, both goal and the locative ‘at’ case marking are covert. So, a locative will generally only be case-marked overtly or inside of an adpositional phrase if it is a source or the adposition is *t̥ək* or *tʰaji* ‘until’, in Hindi and Marwari respectively.

It is common for both the adverbial *wh*_{RC} and the correlate to have the same case marking (129), or for one to be case-marked while the other remains unmarked (130).

13. Alternatively, a degree *wh*_{RC} and degree correlate may also take an adjective as an argument. The possibility of two different adjectives has not been tested at this point.

- b. [*ramnarayan d̂ʒətʰe bətʰo ʔe*] *utʰe*
 Ramnarayan where sitting.M.SG be.PRS.3.SG there.OBL
tʰaji qʰoɾo
 until run.IMP.2.FAM

‘Run to where Ramnarayan is sitting.’

Lit.: ‘Where Ramnarayan is sitting, run until there.’ [MARWARI]

It is also possible for both the *wh*_{RC} and the correlate to be case-marked independently or to be in different PPs, particularly if the *wh*_{RC}-phrase is marked by *tʰaji* ‘until’ and the correlate phrase is marked by *ũ* ‘from’. The relative phrase *d̂ʒəde tʰaji* ‘until when’ in (132a), for example, is associated with the adverbial correlate *vəde* ‘then’ inside of the PP *təde ũ* ‘from then’. Similarly, the locative *wh*_{RC}-phrase *d̂ʒətʰe tʰaji* ‘until where’ in (132b) corresponds to the demonstrative *utʰe* ‘there’ inside of the PP *utʰe ũ* ‘from there’.

- (132) a. *rod̂ʒinə* [*d̂ʒəde tʰaji ənu ho d̂ʒave*]
 every.day when.OBL until Anu sleep go.LGT.IMPV.PRS.3.SG
ram vəde ũ kam kare
 Raam then.OBL from work do.IMPV.PRS.3.SG

‘Every day Raam starts work at the time that Anu gets up.’

Lit.: ‘Every day, what time Anu sleeps until, Raam works from that time.’

[MARWARI]

- b. [Giving instructions in a game.]
isvar [*d̂ʒətʰe tʰaji nave*] *dud̂ʒo*
 Ishwar where.OBL until run.IMPV.PRS.3.SG next
minək utʰe ũ haru kare
 man there.OBL SRC start do.IMPV.PRS.3.SG

‘The next person starts from the place which Ishwar ran to.’

Lit.: ‘Where Ishwar runs until, the next person starts from there.’

The ability of the *wh*_{RC} and the correlate phrase to be case-marked independently is admittedly quite restricted. I spent some time looking at this with several different speakers including both Jodhpur Marwari and Osian Marwari. I found that all of the consultants found examples where the correlate was case-marked but the relative pronoun was not (131) to be acceptable and easily interpreted.

On the other hand, there were only a few combinations of case marking which were easily interpretable. In other cases, even though all of the consultants said that there was nothing incorrect about the sentence, the consultants spent up to ten minutes discussing an example in order to decide if it was grammatical and, if so, what exactly it meant. For example, in nearly every case where the wh_{RC} -phrase is marked by \tilde{u} ‘from’ and the correlate phrase is marked by t^haji ‘until’, such as in (133), the sentence is either ungrammatical or uninterpretable.

- (133) # [*isvər* $\widehat{d}ʒət^he$ \tilde{u} *nave*] *dujō minək*
 Ishwar where.OBL from run.IMPFV.PRS.3.SG other man.M.SG
ut^e t^haji *nave*
 there.OBL until run.IMPFV.PRS.3.SG

‘Ishwar runs up to a certain point, and the next man starts running from there.’

Lit.: ‘Where Ishwar runs from, the next man runs up to there.’

It appears that there is a strong semantic restriction on what case marking combinations are allowed, probably due to restrictions on what can be considered a contextually salient interpretation between the correlative and the correlate.

Despite the restrictions on what case marking is allowed, it is clear from these examples that the adverbial wh_{RC} -phrase and the adverbial correlate may be independently case-marked or generated within separate PPs. Further, both phrase are able to include distinct NPs, exhibiting the same kind of dual headedness as was seen in nominal correlatives. The adverbial wh_{RC} -phrase and adverbial correlate phrase are, therefore, independently generated within the syntax and each have their own semantic contribution.

4.3.5 Adverbial multi-headed correlative construction

The availability of the correlative construction also allows for adverbial multi-headed correlative (MHC) clauses – correlative clauses which include two (or more) relative pronouns which relate to two correlates in the main clause, such as the Hindi examples (134a) and (134b).¹⁴

14. In spoken speech $\widehat{d}ʒət^he t^haji$ ‘until where’ becomes $\widehat{d}ʒət^hayi$.

- (134) a. [MHC *d̂z̄əb se d̂z̄əb tək rəvi skul mē tʰe*]
 when from when until Ravi school in be.PST.M.PL
təb se təb tək us-ki behın gʰar mē kam kar
 then from then until that.OBL-of sister house.OBL in work do
rəhi tʰi
 PROG.F.SG PST.F.SG

'During the time that Ravi was in school, his sister was in the house working.'

Lit.: 'From when until when Ravi was in school, his sister was in the house working from then until then.' [HINDI]

- b. *ənufa* [MHC *d̂z̄ətʰe ï d̂z̄ətʰe tʰaji gandʰi d̂zi*
 Anusha where.OBL SRC where.OBL until Gandhi HON
pa|a-pa|a gija] *utʰe ï*
 on.foot.M.SG.HON-RDP go.PFV.M.SG.HON there.OBL SRC
utʰe tʰaji pa|i-pa|i d̂z̄ai
 there.OBL until on.foot.F.SG-RDP go.FUT.F.SG

'Every journey that Ghandi walked, Anusha will also make that same journey by foot.'

Lit.: 'From where until where Ghandi travelled on foot, Anusha will travel on foot from there to there.' [MARWARI]

The relative pronouns do not have to be of the same variety. As (135), adverbial and nominal *wh*_{RCS} may be used together within the same MHC clause.

- (135) [MHC *d̂zo parivar d̂z̄əhã pe t̂futi ke liye gaye*]
 which family where on holiday for go.PFV.M.PL
un-hõ-ne vəhã bahut maza kiya
 that.OBL-EMPH-ERG there much happiness.M do.PFV.M.SG

'Each family enjoyed where they went on holiday a lot.'

Lit.: 'Which family went where on holiday, they enjoyed there a lot.'

[HINDI]

are available. The availability of adverbial MHCs and the fact that an adverbial wh_{RC} and a nominal wh_{RC} may be used together inside of a MHC clause is further evidence that the adverbial correlative is a true correlative construction.

4.3.6 Summary: Features of the Adverbial Correlative

In this section, I have shown that adverbial correlatives share all of the same semantic features of nominal correlatives. All of the adverbial correlatives except for the temporal correlative are subject to the demonstrative requirement. While they normally occur at the periphery, like nominal correlatives they may be pronounced inside of the main clause preceding the correlate. They show case marking and headedness independent from the associated correlate in the main clause as well. Binding effects also show that the adverbial correlative is base-generated below the subject, at the correlate phrase.

Adverbial correlatives differ from other adverbial clauses¹⁶ which do not allow a correlate in the main clause and which are not usually pronounced inside of the main clause.

If these are true correlative constructions, then the adverbial correlative is also an overtly pronounced index of a demonstrative. In the next chapter, I will show that adverbial correlates are in fact indexical and, like demonstratives, also include a distal and proximal component.

4.4 Adverbial correlatives are not adverbs

In Section 4.3, I showed that adverbial correlatives are a true correlative construction with the same syntactic features as the nominal correlative construction. In this section, I look more closely at the nature of the adverbial correlative and how it relates to the syntax.

The adverbial correlative is often treated as a type of adverbial clause, but looking at its behavior more closely shows that it is not actually an adverb but is actually a nominal phrase. There are two facts about the correlative clause which show this to be the case. First, an adverbial correlative clause

16. Note that I am setting aside the question of whether if/then constructions are underlyingly correlative constructions. For now, (non-correlative) ‘adverbial constructions’ will refer to those constructions which are definitely not correlatives, such as participial phrases. For more information, see Chapter Section 1, Section 1.4.4

Other types of correlatives such as the manner correlative are subject to the demonstrative requirement, as well, and cannot enter the syntax except through the correlate. This is the case even when it is possible for a manner adverbial to appear in that position. If a correlative clause requires a correlate in the main clause, then adverbial correlatives cannot occur without a correlate or, in effect, act as free relatives. The only exception to this is the temporal correlative, which is not subject to the demonstrative requirement.

The demonstrative requirement, while central to the correlative construction, is effectively a stipulation and does not follow from any obvious syntactic restriction. The most obvious restriction on the correlative entering the syntax independently of the demonstrative is the Case Resistance Principle (Stowell 1981). The Case Resistance Principle states that a non-finite clause cannot occur in a case-marked position. This restriction only seems to apply to overt case marking as non-case-marked correlatives are able to occur without a corresponding demonstrative. The nominal correlative, which Bhatt (1997) argues is really a free relative, is able to occur without a demonstrative correlate in the main clause, as shown in (138, repeated from Chapter 2, Section 2.2) and (139).

- (138) [$\widehat{d}\bar{z}o$ $p^h\bar{a}l$ $k^h\bar{a}t:a$ $t^h\bar{a}$] *ramef* *ne* (*vo*) $k^h\bar{a}$ *lija*
which fruit sour be.PST.M.SG Ramesh ERG that eat-take.PFV.M.SG

'Ramesh ate the fruit which was sour.'

Lit.: 'Which fruit was sour, Ramesh ate.' (from Bhatt 1997, p. 56)

[HINDI]

- (139) [*sita* *ne* $\widehat{d}\bar{z}o$ $p\bar{a}k\bar{a}j\bar{a}$] *ram* *ne* $k^h\bar{a}$ *lija*
Sita ERG which cook.PFV.M.SG Ram ERG eat take.LGT.PFV.M.SG

'Ram ate what Sita cooked.' (from Bhatt 1997, p. 56)

[HINDI]

As Bhatt (1997) points out, the demonstrative is optional as long as the argument position of the main clause associated with the correlative or free relative does not include any overt case marking. If the argument position is case-marked, then the demonstrative phrase is obligatory (140).

- (140) [*d̄ʒo s̄abzi k̄aʃi tʰi*] *ḡɔr̄av ne *(us-ko)*
 which vegetables.F sour.F be.PST.F Gaurav ERG that.OBL-ACC
kʰaja
 eat.PFV.M.SG

'Gaurav only ate the vegetables which were unripe/uncooked.'

Lit.: 'Which vegetables were sour, Gaurav ate those.' (*from*

Bhatt 1997, p. 58)

[HINDI]

This shows that the Case Resistance Principle, at least in Hindi, only restricts finite clauses which are overtly case-marked. Finite clauses such as free relatives are able to act as arguments within the main clause, and do not require a corresponding demonstrative, as long as the argument position is not case-marked or, presumably, inside of a PP. The other finite clause which is not subject to the demonstrative requirement is the temporal free relative.

The fact that nominal and temporal free relatives are allowed in Hindi and Marwari as long as they are not in a case-marked position shows that the demonstrative requirement does not follow from a general syntactic restriction on finite clauses entering the syntax directly rather than through a corresponding demonstrative. This does not mean that any finite clause can enter the syntax as a free relative. A locative correlative, for instance, cannot occur in a non-case-marked position independently of the demonstrative, even though it is quite common in Hindi and Marwari for a locative to not have any overt case marking.

The inability of the correlative to enter the syntax is not just a problem for Hindi, Marwari, or MIA. Citko (2009) shows that, even though Polish has free relatives, whyR and whyP correlatives in Polish cannot enter the syntax directly, without a corresponding demonstrative. Both varieties of *why*-correlatives are subject to the demonstrative requirement, as shown in examples (141a) and (141b).

- (141) a. [*Dlaczego Maria zrezygnowała*] **(dlatego) Jan też*
 whyR Maria resign.P.3.SG DEM Jan also
powinien zrezygnować
 should resign.INF

'Jan should resign for the same reason Maria resigned.' (*from*

Citko 2009, p. 54)

[POLISH]

- b. [*Po co Jan wyszedł*] *(*po to*) *samo Maria też wyszła*
 whyP Jan leave.P.3.SG DEM same Maria also leave.P.3.SG
 ‘Jan left for the same reason/purpose Maria left.’ (from
 Citko 2009, p. 54) [POLISH]

Like Hindi and Marwari, other adverbial clauses may act as free relatives in Polish, so the inability of the *why*-correlative to do the same is not due to a syntactic constraint.

Citko concludes that *why* correlatives are subject to the demonstrative requirement because they are not free relatives. I would like to suggest instead that the reason that many of the adverbial correlatives cannot enter the syntax as adverbials is because they can only act as DPs and have the semantic type of entities.

If adverbial correlatives are not, in fact, adverbials, then it follows that they should not be able to occur in adverbial positions within the syntax. An example which illustrates this is the degree correlative construction. Restrictive degree modifier phrases such as *6 feet*, *t̃ʃe fɔt*, or *t̃ʃe fɔtũ* in (142) below are often assumed to denote degrees within the domain D_d .

- (142) a. Ram is [_{deg} 6 feet] tall.
 b. *ram* [_{DdegP} *t̃ʃe fɔt*] *lamba he*
 Raam six foot tall.M.SG be.PRS.3.SG [HINDI]
 c. *ram* [_{DdegP} *t̃ʃe fɔtũ*] *dig:o ε*
 Raam six foot tall.M.SG be.PRS.3.SG
 ‘Raam is six feet tall.’ [KM MAR.]

The degree correlative is also often analyzed as being a phrase of type d (Heim 2000, Bhatt and Pancheva 2004, Beck 2011, Bhatt and Takahashi 2011, among many others). If it were the case that a degree correlative/free relative were of the same semantic type as a degree phrase (i.e., type d), then it follows that a degree correlative should be able to merge with an adjective in the same position that a degree phrase like *six feet* is able to. For instance, just as a degree phrase like *six feet* is able to modify the adjective *tall*, a degree correlative of type d should also be able to modify an adjective. In fact, this is exactly how some authors analyze comparative clauses (von Stechow 1984,

Heim 1985, 2000). Yet, as example (143) shows, a degree phrase cannot enter the syntax as the modifier of an adjective in English, Hindi, or Marwari.

- (143) a. * Ram is [how (much) tall Sita is] tall.
- b. * *ram* [DegP-CorrelCP *d̪ʒɪtni*.F.SG *ləmbi sita hɛ*]
 Raam how.much tall.F.SG Sita be.PRS.3.SG
ləmba hɛ
 tall.M.SG be.PRS.3.SG
Intended: 'Raam is how much tall Sita is tall.' [HINDI]
- c. * *ram* [DegP *d̪ʒɪki dig:i sita ʔɛ*]
 Raam how.much.F.SG tall.F.SG Sita be.PRS.3.SG
ləmbo ʔɛ
 tall.M.SG be.PRS.3.SG
Intended: 'Raam is how much tall Sita is tall.' [MARWARI]

It is not the case that clauses are universally prohibited from acting as restrictive modifiers. Both prenominal and postnominal relative clauses are possible in all of these language. That (143a), (143b), and (143c) are ungrammatical is not due to the fact that there are clausal phrases.

While adverbial correlatives are generally classified as adverbial clauses, in most cases, they are not able to act as adverbials. With only a few exceptions, both adverbial correlatives and nominal correlatives can only enter the syntax where there is a corresponding demonstrative in the main clause. Across MIA, the only free relative construction permitted in the temporal free relative. Similarly, while Polish does allow some free relatives, *why*-correlatives can only occur where there is a corresponding demonstrative.

It is also not possible for the correlative to act as an adverbial modifier phrase. The degree correlative, for instance, is not able to occur in positions where degree phrases are normally allowed. This is not because these are clausal phrases as other types of clauses such as postnominal relatives and participial phrases are able to act as modifiers.

In the next section, I show that, while adverbial correlatives are not able to enter the syntax as adverbials, they are able to act as arguments. This pattern would be unusual if adverbial correlatives were in fact adverbial phrases but follows from an analysis in which both nominal and adverbial correlatives

In another example from Hindi (146), a temporal correlative is able to act as the subject of a copula. The subject here can only be interpreted as a nominal.

- (146) [CorrelCP $\widehat{d\bar{z}\bar{a}b}$ *mē ne skul kətom kija*] *bahut lāmbe*
 when I ERG school finish do.PFV.M.SG very long.OBL
samaj pehele
 time before

'It's been a very long time since I finished school.'

Lit.: 'When I finished school was a very long time ago.' [HINDI]

This does not mean that all of the correlatives can act as the subject of a copula construction. I tested only a few examples of this, and two examples involving a locative correlative were rejected by both the Hindi-Urdu and Marwari consultants, although this may have been for other reasons. The degree correlative was similarly rejected in this type of construction.

Returning to degree correlatives or free relatives, while a degree correlative is not able to enter the syntax as a degree phrase (143), there are languages in which it is able to act as an argument. While degree free relatives are not available in Hindi or Marwari, they are possible in some varieties of English (such as my rural Midlands variety from Missouri).¹⁷

- (147) The secretary made [DegCP how many copies her boss told her to].

Even though this variety of English allows degree free relatives, they are only able to enter the syntax as an argument of the verb phrase and cannot occur in the position of a degree phrase. Consider a situation in which a class has 30 children in it, and the speaker made one cupcake for each child. In this situation, we could expect (147) to be acceptable, but it is not.

- (148) * I made [DegCP how(ever) many kids are in the class] cupcakes.

That degree free relatives act as arguments rather than adverbials is further evidence that correlatives and free relatives are nominal phrases and not adverbial phrases.

17. The degree free relative is not available in all varieties of American English, and they are limited in use. They are often more acceptable with *-ever*, probably because the use of *-ever* presupposes the speaker does not know or is being purposely evasive about how many copies it was.

In Section 4.4.1, I note that there is an exception to the generalization that adverbial correlatives do not act as adverbials but behave like nominals. This is the temporal correlative or free relative construction. The temporal free seems to be able to enter the syntax as a temporal phrase. This does not mean that it is an adverbial phrase but follows from the fact that nominal phrases are able to enter the syntax as temporal phrases. For example, in (149), the DP *har sal* ‘each year’ acts as a temporal modifier of the verb phrase.

- (149) [DP *har sal*] *d̥zyoti apra b^hagīfā maj gəṇa*
 every year Jyoti own garden.M.SG.OBL in many.M.PL
rūṅk^həṛa ləgave
 plant.M.PL attach.IMPFV.PRS.3

‘Every year, Jyoti planted many plants in her garden.’ [MARWARI]

In a similar example in Marwari, the DP *ek dīn* ‘one day’ is also able to act as an adverbial phrase.

- (150) *ek dīn mina viśal ne kajo mē t^ha (re) ũ pārem*
 one day Meena Vishal ACC say.M.SG I you.HON SRC love
karī
 do.SUBJ.1.SG

‘One day, Meena said to Vishal: I am in love with you.’ [OSIAN MAR.]

English also allows DPs to enter the syntax as adverbials. As (151), a DP is able to act as a temporal or a manner phrases.

- (151) a. Monica made pancakes [DP the day the girls arrived].
 b. I did my homework [DP the way the teacher told me to].

I posit that there is a covert adposition which allows nominals to enter the syntax as adverbial phrases. This is the case both for the Hindi and Marwari temporals and for English temporal and manner phrases.¹⁸ One evidence that there is a covert adposition in these constructions is that sentences like (151) may alternatively position the temporal DP inside of a PP, as illustrated in (152).

18. It does not seem to be possible for nominals to occur in place of locatives or degree adverbials. The lexical entry of the covert adposition, therefore, is restricted to certain types of adverbials and varies cross-linguistically.

(152) Monica made pancakes [PP on [DP the day the girls arrived]].

The temporal free relative or correlative, therefore, is not different from other correlatives because it is an adverbial phrase where the other correlatives are not but follows from the availability of a covert adposition which allows a DP to enter the syntax as an adverbial phrase.

To conclude, there is strong evidence that an adverbial correlative is not an adverbial phrase but is, in fact, a nominal phrase denoting an entity of type e. A correlative is only able to act independently of an indexical correlate when it able to enter the syntax as a (non-case-marked) nominal argument or where a covert adposition allows it to occur in an adverbial position. Otherwise, both nominal and adverbial correlative clauses can only enter the syntax as part of the same constituent as a demonstrative.

4.4.3 Mismatched correlative constructions

There is another type of evidence which shows that the adverbial correlative denotes an entity of type e, and that is the availability of mismatched kinds of correlatives and correlates. There are cases in which an adverbial correlative corresponds to a nominal demonstrative. I propose that this type of construction is available because adverbial correlatives are, in fact, nominals.

Most descriptions of adverbial correlatives assume that the variety of correlative (or more specifically, the relative pronoun) always matches the variety of the demonstrative. That is, in nearly all of the examples, a degree correlative always corresponds with a degree demonstrative, a locative correlative always corresponds to a locative correlate, a manner correlative always corresponds to a manner correlate, etc. In this section, I will show that this is not necessarily the case, and it is possible to have what I will call *mismatched* correlative constructions. A correlative construction is mismatched when the variety of the correlative is not the same as the variety of the correlate. As the following examples show, this will mean that there must either be some mechanism within the correlate to allow for indices of different types, or all indices are of the same semantic type.

Consider (153), in which a nominal demonstrative *vo* ‘that’ is associated with a correlative clause headed by the locative *wh_{RC} āʒəhā* ‘where’.

- (153) [*ḍāhā rohit kam karta he*] **(vo) dukan*
 where Rohit work do.IMPV.M.SG PRS.3.SG that store
pehele aṭhā restrant thā (lekin abhi nuhī)
 before good.M.SG restaurant be.PST.M.SG but now NEG

'Where Rohit works, that used to be a good restaurant (but now it is not).'

[HINDI]

It is not only locative correlatives which can relate to a nominal demonstrative. In (154), the temporal correlative *ḍāḍe ap:a spiti re kane ḍero lagaijo* 'when we went camping near Spiti' may relate to either a nominal demonstrative, *un* 'that.OBL' in *un ḍāge mē*, or to an adverbial correlate *uthe* 'there'. The correlate here cannot be referring to *spiti* 'Spiti' because the wallet was lost *spiti re kane* 'near Spiti' and not in Spiti itself.

- (154) [*ḍāḍe ap:a spiti re kane ḍero lagaijo*] *mē*
 when we.INCL Spiti near camp.PFV.M.SG I
{uthe / un ḍāge mē} maro bātuḍa gāmo diyo
 there / that place in my.M.SG wallet lose give.LGT.PFV.M.SG

'When we camped near Spiti, I lost my wallet {there/at that place}.'

[MARWARI]

These types of correlative-nominal demonstrative combinations do not just come from elicitation. In an example from the Hindi storybook *sāmudr tṭ pṛ* 'on the beach' by OV Vijayan, a nominal demonstrative takes a manner adverbial clause as an argument. In the story, a family is visiting the beach and the little boy is scared when the sand moves out from under his feet so that he begins sinking. His father reassures him, saying (155).¹⁹

19. Rajesh Bhatt (p.c.) suggests that it may be possible to interpret the relativized clause in (155) as a free relative, where the demonstrative *vo* 'that' refers to the water rather than the way that the water moves back into the ocean. This would require that this variety of Hindi allow manner free relatives and that manner clauses such as *ḍese pani sāmudr mē vapas ḍāta hē* 'the manner in which the water returns to the ocean' to occur without a corresponding demonstrative correlate. That is, *ḍese* 'manner' head correlatives would not be subject to the demonstrative requirement. Because both the Hindi and Marwari varieties that I looked at do not allow manner free relatives, and manner correlative were always subject to the demonstrative requirement, I assume that the demonstrative *vo* 'that' in (155) refers to the full manner clause.

must be some mechanism within the syntax which allows an entity to act as a temporal adverbial (i.e., a free relative).

The second piece of evidence that adverbial correlatives are of type e is that it is possible for there to be an apparent mismatch between the demonstrative and the correlative clause. That is, it is possible for a adverbial correlative to correspond to a nominal correlate, and vice versa. Further, an adverbial correlate may alternatively relate to another variety of adverbial correlate. In order to account for this, we must either assume that all correlates include some mechanism within their lexical entry which allows them to take an index from a variety of semantic types, or we can take a far more straight-forward approach and assume that all correlatives (both nominal and adverbial) are of type e.

This approach not only accounts for mismatched correlatives but also for the fact that adverbial correlatives cannot act as adverbial phrases. Instead, adverbial correlatives can only enter the syntax as part of the DemP constituent or as nominals.

In this next chapter, I show that not only is this type of analysis possible but that it follows directly from a Zwarts and Winter (2000) and Svenonius (2000, 2004) style analysis of the locative prepositional phrase, which includes a reference object of type e at its core.

4.5 Conclusion

The adverbial correlative, even though it is headed by an adverbial relative phrase, has the same syntactic features as the nominal correlative discussed in Chapter 2. These features (Section 4.3) are repeated below.

(159) Typical features of a correlative construction:

- (a) There must be an appropriate correlate, either a demonstrative or a pronominal, in the main clause (*the demonstrative requirement*)
- (b) Are base-generated to the left of the associated phrase, as part of the same constituent, and may then optionally be fronted.
- (c) Headed by a relative pronoun (wh_{RC}), which may remain in-situ.

- (d) The relativized element may appear in both the relative clause and the correlative (*headedness*), and both the wh_{RC} and the correlate may be case-marked independently.
- (e) Correlatives license multi-headed relative clauses.

Like the nominal correlative, the adverbial correlate is base-generated within the same constituent as the correlate. The adverbial correlative allows dual headedness and independent case marking, and all but the temporal adverbial correlate are subject to the demonstrative requirement. The adverbial correlative also allows for a multi-headed correlative construction.

Although the adverbial correlative is headed by an adverbial relative phrase, it is not actually an adverbial phrase. Section 4.4 shows that adverbial correlatives are not able to occur in the same positions as other adverbial phrases (Section 4.4.1). Further, where adverbial correlatives are able to enter the syntax independently of a demonstrative, they act as nominals rather than as adverbials (Section 4.4.2). The only exception to this is the temporal correlative construction headed by $\widehat{d}3ab$ or $\widehat{d}3ad$ ‘when’ in Hindi and Marwari. This is not a true counter-examples, though, because DPs are able to enter the syntax as adverbials, as well, through a covert adposition.

Further, the availability of mismatched correlative constructions is further evidence that the adverbial correlative actually denotes an individual of type e (Section 4.4.3). It is possible for adverbial correlatives to relate to nominal demonstratives and to other varieties of adverbial correlates. Nominal correlatives may also correspond to adverbial correlates. If adverbial correlatives are adverbial, this would require a large number of type-shift or sortal operators to allow these types of constructions. Even if such a sort operation were available, this would not account for why adverbial correlatives are not able to enter the syntax as adverbials.

In Chapter 3, I argued that the nominal correlative is an overt pronunciation of the index of a demonstrative. In Chapter 5, I show that the same analysis holds for adverbial correlatives, as well. I also discuss the internal syntax of the adverbial correlate and show through deferred reference that it is a demonstrative, as well.

Chapter 5

The demonstrative nature of the adverbial correlative

5.1 The adverbial CorrelCP-correlate constituent

In Chapter 3, I presented an analysis of the nominal correlative as the overt pronunciation of the index of the demonstrative correlate. In this chapter, I show that the same analysis will apply to adverbial correlatives, as well.

In Section 5.2, I outline an analysis of the internal structure of adpositional phrases based on Svenonius (2010, 2008) and Zwarts and Winter (2000)'s analyses of locative prepositional phrases. I propose that a locative postposition phrase in Hindi, Marwari, and other MIA languages has the structure (1).

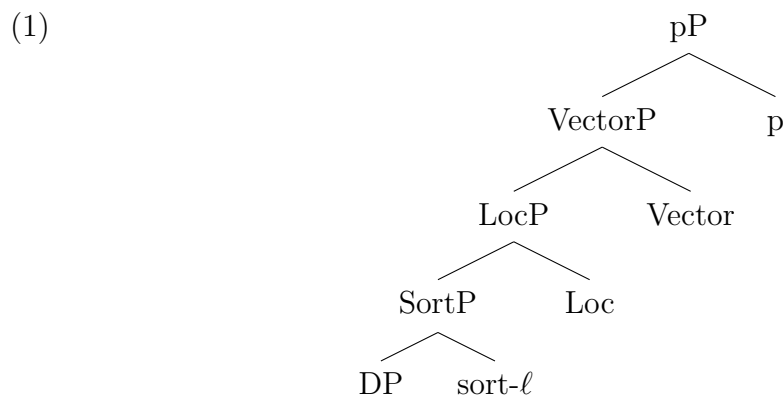

At the core of the locative phrase is a nominal reference object. The location contributed by the PP is defined in terms of the location of this object. It is *sort-l* which takes a DP as an argument and yields a location.

Assuming that *sort-l* is one variation of a SORT projection allows the same

analysis to be extended to other types of adverbial adpositions such as temporal phrases. The SORT-head therefore takes a nominal and yields a location, time, manner, or degree of the appropriate type.

In Section 5.3, I propose that the underlying structure of the adverbial demonstrative also includes the same SORT head found in nominals. The structure also includes several of the same components found in the nominal demonstratives, including an index, a relation R, and a demonstrative head PROX or DIST which carries the classificatory information such as definiteness (2).

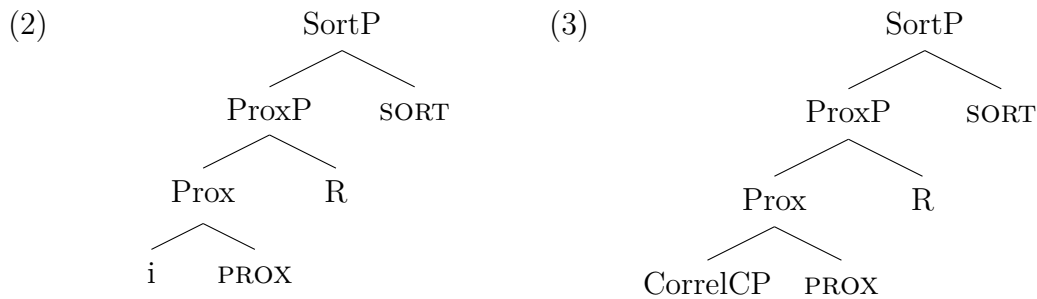

In Chapter 3, I argued that the nominal correlative is the overt pronunciation of the demonstrative correlate. In Section 5.4 of this chapter, I show that the adverbial correlative is also an overtly pronounced index.

Chapter 4 argued that adverbial correlatives are not adverbial phrases but, instead, act as nominals. It is the sort phrase which allows an adverbial demonstrative to take a nominal or adverbial correlative as its index. Just as sort- ℓ takes a nominal reference object as its argument, the SORT projection of the adverbial demonstrative will take the individual contributed by the proximity phrase ProxP.

If the correlative construction is truly an overtly pronounced index, then it follows that they should also display deferred reference just as demonstrative and pronominals do (see Chapter 3). In Section 5.4.2, I show that deferred reference is possible in the adverbial correlative construction just as it is in nominal correlatives.

5.2 Internal structure of locative PPs

Broadly, Zwarts (1997) and Zwarts and Winter (2000, from here on Z & W) propose that a prepositional phrase denotes a set of vectors, where a vector

is a quantity which has both direction and magnitude and which relates the position of one point in space to another. This set of vectors originates at a point or region defined in relation to a reference object. For instance, *from the house* denotes a sector of vectors which originate at the region occupied by the house – its eigenspace.

(4) John came from behind the house.

Looking ahead, I propose that a VP which includes an event modifying postpositional phrase (PP) has the following structure (cf., Zwarts 1997, Svenonius 2010, Ramchand and Svenonius 2007), reflecting the Hindi word order. I have listed the semantic contribution of each component below for reference (6), but will walk through the derivation of the PP step by step below. Locations (ℓ) are of type ℓ .

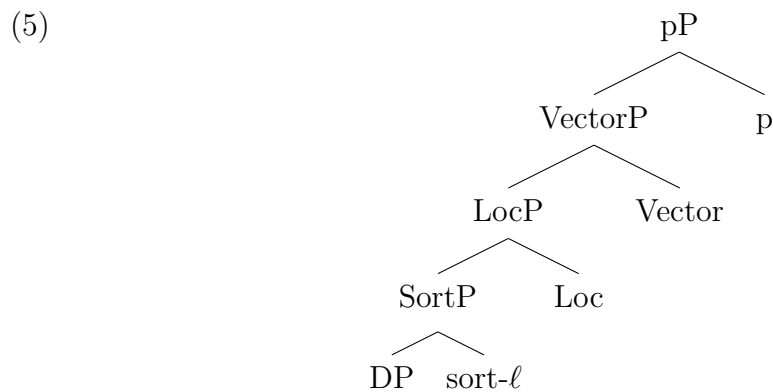

- (6) The locative SORT operator $\llbracket \text{sort-}\ell \rrbracket = \lambda x_{\langle e \rangle} . \lambda \ell_{\langle \ell \rangle} . \text{EIGEN}(x, \ell)$
 $\text{EIGEN}(x) =$ the region or location which the reference object occupies
 $\llbracket \text{Loc} \rrbracket = \lambda f_{\langle \ell t \rangle} . \lambda \ell'_{\langle \ell \rangle} . \exists \ell_{\langle \ell \rangle} . f(1) = 1 \ \& \ P(\ell, \ell')$, where P is the property contributed by the Loc adposition.
 $\llbracket \text{Vector} \rrbracket = \lambda f_{\langle \ell t \rangle} . \lambda v_v . \exists \ell' . P(v, \ell') \ \& \ f(\ell') = 1$ where P is the property contributed by the VECTOR head

Svenonius (2004, 2010, 2008) proposes that the vector phrase or adpositional phrase is able to enter the syntax through a little-p projection. Because a PP is able to modify both events and entities, I define p_{event} and p_{entity} as follows.

- (7) $\llbracket p_{\text{event}} \rrbracket = \lambda f_{\langle v, st \rangle} . \lambda e_s . \exists v . f(v) = 1 \ \& \ \text{LOC}(e, v)$
 $\llbracket p_{\text{entity}} \rrbracket = \lambda f_{\langle v, et \rangle} . \lambda x_e . \exists v . f(v) = 1 \ \& \ \text{LOC}(x, v)$

To give an idea of where the analysis is headed, having shown how a PP is composed, I show that the same internal components are reflected in the locative demonstrative. The reference object of the Hindi demonstrative $\widehat{d\bar{3}a-h\bar{a}}$ ‘here’ or English *here*, for instance, is the interpretation of the proximal index through the contextually salient relation R. The SORT operator which is a component of the adverbial PP and which defines a region in terms of a reference object is also a component of the adverbial demonstrative.

Adverbial demonstratives vary according to what kind of SORT operator they include – specifically, whether it is locative, temporal, a degree operator, etc.

5.2.1 The eigenspace of the reference object

Zwarts and Winter (2000) propose that, at the heart of the locative phrase, there is an entity or object whose location is the source of the set of vectors denoted by the adpositional phrase. This object is what they call the *reference object* or what has been referred to as the *ground* (Talmy 1978, 2000). Looking at (8) again, *the house* is the reference object of the PP *from behind the house*.

(8) John came from behind the house.

A locative PP denotes a set of vectors defined in relation to a location ℓ . This location is the the space occupied by the reference object, the house (Zwarts and Winter 2000). Following Wunderlich (1991), Z & W call this region the *eigenspace* of the reference object (Svenonius’ *eigenplace*).

Svenonius (2010) defines EIGEN(x), the relation of being the eigenspace of the reference object, as the set of points which the reference object occupies. I follow Svenonius in assuming that the eigenspace of an object is a region or location EIGEN(x) in domain D_ℓ . But, rather than assuming that EIGEN(x) denotes a set of points, I treat EIGEN as a function from an object to a region or location. EIGEN(x) is therefore defined as (9)

(9) Given some reference object x,
 $EIGEN(x) = \ell$, the region or location which the reference object occupies

The distinction is that, under Z & W and Svenonius’ analysis, the eigenspace or region occupied by the reference object is a set of points. The location defined by the PP, then, is defined in reference to a point or set of points within this region.

Instead, I will assume that points are simply a subset of regions where a point is defined as a region which is treated as indivisible – that is, none of the locations within it are accessible. I diverge from Z & W slightly in assuming that both points and regions are type ℓ ; a point is simply a specific type of location.

(10) A point may be defined as an indivisible region or location.

The *eigenspace* of a reference object, then, is the region occupied by the reference object where that region is made up of smaller (contiguous) regions.

One reason for defining the eigenspace as a location rather than a set of points is the interpretation of plural reference objects. Consider (11) from Z & W (attributed to Herskovits 1986 and M. Faller, unpublished manuscript).

(11) There is a worm in the strawberries.

If the eigenspace of the reference object *the strawberries* is only the set of points which are occupied by the reference object, then the eigenspace will only include the space occupied by the strawberries themselves and not the space between them. Further, the set of points does not necessarily have to be contiguous. Given this strict definition of eigenspace, (11) is only felicitous when there is a worm which is partially inside of one strawberry and partially inside of another. In natural speech, though, it would be quite natural to interpret (11) to mean that there is a worm crawling in the space between the strawberries.

Z & W overcome this issue by assuming that the eigenspace is convex – that is, it may include regions which are not actually points occupied by the reference object but also empty space bounded by the object (for example, the inside of a bowl).¹ They therefore suggest that the worm may be ‘in the convex hull of the strawberries’ (p. 201). The eigenspace of a plural object may therefore include regions which are not actually occupied by the reference object but also the empty space bounded by those objects, as long as the eigenspace is contiguous.

Treating the location as an object which may be made up of other location objects is analogous to Link (1983)’s plural individual, where a plural individual is treated as a singular object but which is made up of plural objects and whose individual members may be accessible.

1. The eigenspace is also assumed to be closed (properly contained in D_p or D_ℓ and non-trivial (non-empty) (Zwarts and Winter 2000, p. 177).

In conclusion, a locative phrase denotes a set of vectors defined in terms of a nominal reference object. In Section 5.4, I show that adverbial demonstratives also include some of the components of adverbial PPs. These same components are also part of the adverbial wh_{RC} -phrase (See Chapter 6).

5.2.2 The SORT phrase

If the locative phrase is defined in relation to the eigenspace of some object, then there must be a projection in the syntax which allows an operator to relate a reference object to its eigenspace. This is the primary function of Z & W's LOC head and of Svenonius' case-marking projection K(ase). I instead call this the SORT head and define it in such a way that the different kinds of adverbial demonstrative will vary by what kind of SORT operator they include.

For Z & W, this head is a location function LOC which assigns any physical entity in D_e its location in space, i.e., its eigenspace. Svenonius (2010) assumes that in examples like *outside of* in English, *of* is an overt pronunciation of the Kase (K) head.

Svenonius (2010) refers to the function of the KP (aka SORT head) as type shifting, but this kind of type-shifting does not act in the same way as other type shifters and may be more appropriately called a sort-shifter (suggested by Veneeta Dayal, p.c.). I define the sortal head $sort-\ell$ using the same definition as Svenonius gives for the K head; $sort-\ell$ has the semantic contribution in (12), below.

$$(12) \quad \llbracket sort-\ell \rrbracket = \lambda x_{\langle e \rangle} . \lambda \ell_{\langle \ell \rangle} . EIGEN(x, \ell)$$

Because the sortal head does not always refer to a location, I will define SORT more generally as given in (13). This not only better reflects what the SORT head does but allows the analysis to be extended to other types of adverbial phrases such as temporal, manner, degree phrases, etc.

$$(13) \quad \llbracket SORT \rrbracket = \lambda x . \lambda z_n . SORT(x, z_n) \text{ where } SORT \text{ is an operator which takes some entity } x \text{ and yields a function of regions, manners, degrees, etc. } (z_n) \text{ defined in relation to that object}$$

The SORT operator takes the reference object and gives some other type of set which is defined in relation to that object. In the case of the location PP, $sort-\ell$ takes the reference object as its arguments and yields a location (ℓ) which is the eigenspace of that reference object.

The locative sort-phrase (SortP_ℓ) in a languages with postpositions, such as Hindi or Marwari, has the structure (14).

$$(14) \quad \begin{array}{c} \text{SortP}_\ell \\ \wedge \\ \text{DP} \quad \text{sort-}\ell \end{array}$$

Applying $\text{sort-}\ell$ to an example like *from near the house*, SortP has the following contribution.

$$(15) \quad \begin{aligned} \llbracket \text{SortP}_\ell \rrbracket &= \llbracket \text{sort-}\ell \rrbracket(\text{the house}) \\ &= \lambda x_{\langle e \rangle}. \lambda \ell_{\langle \ell \rangle}. \text{EIGEN}(x, \ell)(\iota x. x \text{ is a house}) \\ &= \lambda \ell_{\langle \ell \rangle}. \text{EIGEN}(\iota x. x \text{ is a house}, \ell) \end{aligned}$$

This is equivalent to:

$$(16) \quad \lambda \ell. \iota x (\text{EIGEN}(x, \ell) \wedge x \text{ is a house})$$

In the case of the locative adverbial, the sort-phrase itself is of type ℓ .

The SORT operator will therefore yield a manner, kind, time, degree, etc. depending on which SORT-head is employed. What varieties or ‘flavors’ of the sort operator are available is language specific. This allows the analysis to be extended to other types of adverbial phrases and, ultimately, to the full range of adverbial demonstratives (see Section 5.3).

5.2.3 The syntax of locative PPs

The most important part of the PP structure for adverbial demonstratives will be the eigenspace of the reference object and the sort-phrase SortP , as both of these components are also part of the adverbial demonstrative. Before moving onto the adverbial demonstratives, though, I give a brief outline of the rest of the locative PP which will be useful for later discussion.²

The locative PP includes two levels of prepositions (Svenonius 2010, 2008). In (17), for instance, there is an internal PP which defines a location, *inside the house*, and an external PP layer, *from inside the house*, which defines a path or vector originating at this location.

2. Svenonius (2010, 2008) and Ramchand and Svenonius (2007) propose several other projections within the syntax of the of the PP including a degree phrase DegP and an Axial Part phrase AxPartP . Because these are not relevant here, I will not include these projections as part of this discussion.

(17) [PP₁ from [PP₂ behind [DP the house]]].

For the sake of clarity and to avoid committing to any specific theory on the differences between the two P-layers (sometimes referred to a Path and Place), a region denoting preposition such as *near* a Loc projection.

I define the Loc projection slightly differently than previous analyses have done. Zwarts and Winter (2000) and Svenonius (2010) both assume that the eigenspace is a set of locations of type $\langle pt \rangle / \langle lt \rangle$, respectively, and that there is a projection which shifts from these sets of locations directly to vector space.³ Instead of assuming that LocP denotes a set of vectors, I suggest that LocP denotes a region ℓ' defined in relation to ℓ . Loc is therefore a function from a region ℓ , where ℓ is the eigenspace of the reference object, to a region ℓ' . The location ℓ' may be outside of the eigenspace of the reference object ℓ , inside of ℓ , or at ℓ . The lexical entry for LOC is (18).

(18) $\llbracket \text{Loc} \rrbracket = \lambda f_{\langle lt \rangle} . \lambda \ell'_{\langle \ell \rangle} . \exists \ell_{\langle \ell \rangle} . f(\ell) = 1 \ \& \ P(\ell, \ell')$
 where P is the property contributed by the Loc adposition.

LocP *behind the house* has the structure (19).



The Loc head or preposition *behind* in English would then have the following lexical entry (20). The derivation of the LocP *behind the house* is shown in (21).

(20) $\llbracket \text{behind} \rrbracket = \lambda f_{\langle lt \rangle} . \lambda \ell'_{\langle \ell \rangle} . \exists \ell_{\langle \ell \rangle} . f(\ell) = 1 \ \wedge \ \text{behind}(\ell, \ell')$

(21) $\llbracket \text{behind the house} \rrbracket = \llbracket \text{behind} \rrbracket (\llbracket \text{SortP} \rrbracket)$
 $= \lambda f_{\langle lt \rangle} . \lambda \ell'_{\langle \ell \rangle} . \exists \ell_{\langle \ell \rangle} . f(\ell) = 1 \ \wedge \ \text{behind}(\ell, \ell') (\lambda \ell_{\langle \ell \rangle} . \text{EIGEN}(\iota x . x \text{ is a house}, \ell))$
 $= \lambda \ell'_{\langle \ell \rangle} . \exists \ell_{\langle \ell \rangle} . \text{EIGEN}(\iota x . x \text{ is a house}, \ell) \ \wedge \ \text{behind}(\ell, \ell')$

Zwarts and Winter (2000) propose that a locative P is a function which applies to the set of points in the eigenspace of the reference objects and returns

3. Zwarts and Winter (2000) refer to this as the locative P (P_{LOC}) while Svenonius (2010) calls this the Loc head.

a set of vectors. Vectors, indicated by arrows, are a relationship between points or locations which are defined in terms of magnitude and direction. (Their analysis only includes one P layer.) I follow Z & W and Svenonius in assuming that vectors have their own semantic type, $v_n \in D_v$. I define the Vector head as (22).

$$(22) \quad \llbracket \text{Vector} \rrbracket = \lambda f_{\langle \ell t \rangle} . \lambda v_v . \exists \ell' . P(v, \ell') \wedge f(\ell') = 1$$

where P is the property contributed by the VECTOR head

Returning to (17), *from behind the house* then denotes the set of vectors whose source (SRC) is the location *behind the house*. The lexical entry for *from* is (23).

$$(23) \quad \llbracket \text{from} \rrbracket = \lambda f . \lambda v . \exists \ell' . \text{SRC}(v, \ell') \wedge f(\ell') = 1$$

The derivation of the vector phrase *from behind the house* is (24).

$$(24) \quad \llbracket \text{VectorP} \rrbracket = \llbracket \text{from behind the house} \rrbracket$$

$$= \lambda f_{\langle \ell t \rangle} . \lambda v_{\langle v \rangle} . \exists \ell'_{\langle \ell \rangle} . \text{SRC}(V, \ell') \wedge f(\ell') = 1 (\lambda \ell'_{\langle \ell \rangle} . \exists \ell_{\langle \ell \rangle} . \text{EIGEN}(\iota x . x \text{ is a house}, \ell) \wedge \text{behind}(\ell, \ell'))$$

$$= \lambda v_{\langle v \rangle} \exists \ell'_{\langle \ell \rangle} . \exists \ell_{\langle \ell \rangle} . \text{SRC}(V, \ell') \wedge \text{EIGEN}(\iota x . x \text{ is a house}, \ell) \wedge \text{behind}(\ell, \ell')$$

Svenonius (2004, 2008) proposes that there is a little-p projection, analogous to the little-n (Van Riemsdijk 1990) projection and little-v projection (Kratzer 1996), which allows the PP to enter the syntax. Cross-linguistically, adpositional phrases are able to modify either events or noun phrases. In order to account for this, I propose that there are actually two varieties of p projection, namely the p_{event} which modifies events and p_{noun} which modifies noun phrases. More precisely, p_{event} is a function from vectors to events, and p_{entity} is a function from vectors to individuals.⁴

$$(25) \quad \llbracket p_{\text{event}} \rrbracket = \lambda f_{\langle v, st \rangle} . \lambda e_s . \exists v . f(v) = 1 \wedge \text{LOC}(\text{ATION})(e, V)$$

$$\llbracket p_{\text{entity}} \rrbracket = \lambda f_{\langle v, et \rangle} . \lambda x_e . \exists v . f(v) = 1 \wedge \text{LOC}(\text{ATION})(x, V)$$

4. While both p_{event} and p_{entity} are available in English, only p_{event} is available in Hindi and Marwari.

5.2.4 The adverbial adpositional phrase

At the core of every adpositional phrase, there is a noun phrase or reference object. Within the syntax, SORT projection such as SORT takes the reference object as an argument and yields a location. This location, Z & W propose, is the eigenspace of the reference object. Defining the SORT operator in this way allows this analysis to be extended to other types of adverbial phrases such as temporal, manner, and degree phrases.

The syntactic structure of the locative PP, reflecting the Hindi word order, is (5, repeated from above).

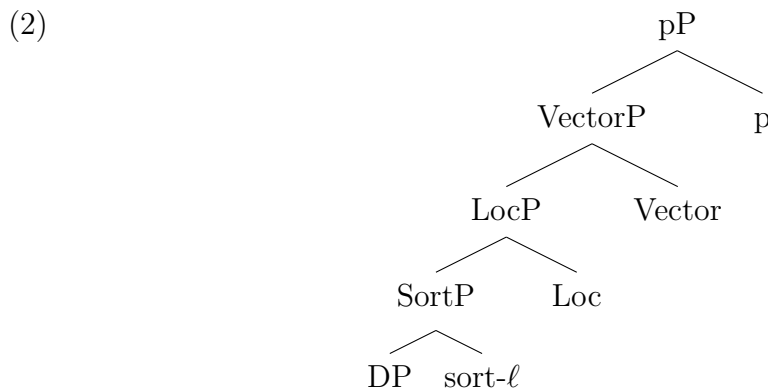

The Loc projection defines a second location ℓ' in relation to ℓ . The PP or VectorP then denotes a set of vectors which are defined in relation to some location ℓ' . The vector phrase may then enter the syntax as an adverbial through a little-p projection, p_{event} or p_{entity} .

The sort-phrase is not limited to the adpositional phrase but is also a component of the adverbial demonstrative phrase. In Chapter 3, I showed that adverbial correlatives are not adverbial but are nominals and denote individuals of type e.

In the next section, I show that adverbial correlates are, in fact, adverbial demonstratives. Further, adverbial demonstratives do not take adverbs as their index but nominal. It is the sort-phrase which allows these to have their adverbial interpretation. It will also be the sort-phrase which will allow an adverbial correlative, which denotes an individual, to enter the syntax as the overtly pronounced index of an adverbial demonstrative.

5.3 The adverbial demonstrative

Having given an account of the non-indexical adverbial PP (Section 5.4), I will now turn to the adverbial correlate, or what is really an adverbial demonstrative.

If the adverbial correlative is a true correlative construction, then it follows that the adverbial correlate is an indexical. In order to demonstrate that this is indeed the case, following Nunberg (1993) I show that the adverbial correlate displays the same kind of deferred reference that nominal indexicals do (Section 5.3.1). Section 5.4 combines what we know about indexicals and what we know about correlatives into a unified analysis of the adverbial correlative.

5.3.1 Deferred reference and adverbials

Nunberg (1993) proposes that indexicals are made up of four components (see Chapter 3, Section 3.2). One of these is a relational component within the demonstrative which relates the index to the interpretation in the main clause. He suggests that this relation is made apparent though deferred reference – that is, in cases where the index and the interpretation are not the same. Just as deferred reference allows the index to differ from the interpretation in nominal demonstratives, this is possible in adverbial demonstratives, as well. Temporal indexicals, for instance, can be shown to allow deferred reference or a mismatch between the index time and the interpretation in the main clause. (26) is from a university newspaper at the start of a new school year (from Nunberg 1993, credit to Dick Oehrle). The temporal indexical is underlined.

(26) The bookstore crowds usually abate a week from now.

The interpretation of (26) is something like the following.

(27) In any given year, the bookstore will be less busy a week after the opening of term than it is on the day that term starts.

Further, (26) cannot be interpreted as (28).

(28) On September 22, 1991, the book store crowds are always less busy than they are now.

In this case, the day that term starts happens to be ‘now’ at the speech time t , from the perspective of the speaker a , in the real world w_0 . The index

picks out the time of the speech act along with its relevant characteristics – in this case, marking the start of the school year. The interpretation of the indexical *now* in this case is ‘the time in any given year characterized by the start of the school year’.

Other temporal indexicals show deferred reference, as well. In the following, the Marwari adverbial *kale* ‘tomorrow’ refers to the first Friday of the school year, which happens to be ‘tomorrow’ from the reference of the speaker at the speech time. The index of the indexical tomorrow is the day that the statement was made – September 19, 2016, for example. The interpretation in the main clause, though, is the first Friday of every academic year.

- (29) *kale hames bār mē heṅ ũ moto tevar hē*
tomorrow always year in all from big.M.SG party be.PRS.3.SG

‘Tomorrow is always the biggest party of the year.’ (*adapted from*
 Nunberg 1993:29) [MARWARI]

Locative indexicals can behave similarly in allowing deferred reference, picking out a specific location and receiving an interpretation of a series of locations distributed over places with the same characteristics. Take for example (30a) and (30b).

- (30) [A medical pathologist points at his own chest and says:]
 a. A gunshot wound here usually indicates that the death was
 not suicide.
 b. [CorrelCP *āḷāde koi mināk aṭḥe goli mare*]
 when some man here gunshot hit.IMPFV.3.SG
a lagetāge aṭḥam hātija ni hē
 that.F.SG usually suicide NEG be.PRS.3.SG

‘When someone is shot here, that is not usually suicide.’ [MARWARI]

Clearly the pathologist is not pointing to a literal gunshot wound on his own chest, nor is he implying that he has died, of suicide or otherwise. The interpretation of *here* can only be ‘the center of the chest on the body of a person who has died’.

In all of the examples so far, the locations and times distribute over a large group of individuals, whether it be years or bodies. Non-distributive examples

in which the index selected by the demonstrative and the interpretation are two different individuals are possible as well. For example, if I were to attempt to call Jess at his workplace, the operator may say the following (adapted from Nunberg 1993, p. 29).

(31) Jess no longer works here.

This is a perfectly felicitous, even in a situation where the business has changed location since Jess worked there, or even if the business itself has several work sites and Jess has always worked at one of the other sites. The index picks out the building or location where the operator is located, but the interpretation is XYZ Unlimited, the company which Jess works for.

The operator does not intend for (31) to be interpreted as (32).

(32) Jess used to work at the location 1234 Main Street, but does not work at that location any longer.

The interpretation of (31), then, is something like (33), which can be restated more precisely as (34).

(33) Jess no longer works for XYZ Unlimited.

(34) Jess no longer works at the company associated with or which is represented by 1234 Main Street, a location which is proximal according to the speaker at the time of the speech act.

Nunberg (1993) concludes from the fact that adverbial phrases such as *here* and *kale* 'tomorrow' allow deferred reference shows that they are made up of the same components as the nominal demonstrative. Adverbial demonstratives thus include an index *i*, a relation *R* between the index and the interpretation in the main clause, and classificatory information including proximity and definiteness features.

The formalization of the adverbial indexical will very closely follow the formalization of the pronominal and demonstrative indexicals. The adverbial demonstrative includes the same components as the nominal DemP, listed in (35, see Chapter 3, Section 3.2).

(35) Components of the demonstrative

1. an *index* which picks up its meaning from something in the context which may be a location, time, manner, or degree.
2. *classificatory* information contributed by the lexical item, including definiteness features, distal features, and other culturally relevant information.
3. a *relation* R which denotes some contextually salient relationship between the index and the interpretation
4. an *interpretation* within the main clause

Following Elbourne (2008), I assume that the index is a variable which gets its meaning via *Variable Interpretation*.

(36) *Variable Interpretation*

For all natural numbers n and assignment functions g , if i_n is a variable with subscript n , then

$$\llbracket i_n^g \rrbracket = g(n)$$

provided n is in the domain of g ; $\llbracket i_n^g \rrbracket$ is undefined otherwise.

The R relation is again a contextually salient relationship which relates the index to the interpretation in the main clause. The relation will often be something like ‘equivalent to’ or ‘represented by.’

In addition to the components listed in (35), I propose in the next section that adverbial demonstratives also include a sort-phrase. The sort-phrase is roughly analogous to the NP in nominal demonstratives; it sorts the entity picked out by the index and gives a related location, time, manner, kind, etc. The sort-phrase may act in tandem with an overt NP such as those found in a kind adverbial, or possibly with an adjectival element such as in degree phrases.

5.3.2 Syntax of the locative demonstrative

The locative demonstrative is made up of the same components as the nominal demonstrative along with a sort-shifter to locations. Consider a situation in which the speaker points to an empty box and then says the following:

(37) Put the papers in here [gesture toward an empty box].

Like other indexicals, the index gets its meaning through variable interpretation (Elbourne 2008). The relation R is the same as well and may vary according to the context.

(38) $\llbracket R \rrbracket = \lambda y. \lambda x_{\langle s, e \rangle}. \lambda s. x(s) = y$

The proximity head is similar to the semantic contribution Elbourne (2008) suggests for the English pronoun *it* (39) except that, like the demonstrative, it also contributes information about the proximity of the index.

(39) $\llbracket it \rrbracket = \lambda f_{\langle se, st \rangle}. \lambda s. \iota x (f(\lambda s'. x)(s) = 1)$

Looking ahead, I propose the lexical entries in (40) for the proximity heads $\text{PROX}_{\text{simplex}}$ and $\text{DIST}_{\text{simplex}}$ in adverbial demonstratives.

(40) $\llbracket \text{PROX}_{\text{simplex}} \rrbracket = \lambda x_e. \lambda f_{\langle se, st \rangle}. \lambda e_s. \iota z (f(x)(\lambda e'_s. z)(e) = 1 \wedge \text{PROX}(x, a, t))$
 $\llbracket \text{DIST}_{\text{simplex}} \rrbracket = \lambda x_e. \lambda f_{\langle se, st \rangle}. \lambda e_s. \iota z (f(x)(\lambda e'_s. z)(e) = 1 \wedge \text{DIST}(x, a, t))$

The adverbial or simplex proximity heads are so called because, the pronominal, they only take the index as an argument and do not include an NP sortal phrase.

If the adverbial demonstrative include the same components as other indexicals, then the next question is how those components combine. There are two options for how the components of the adverbial demonstrative come together, according to whether the proximity scopes over *i* (41a) or the relation phrase RelationP as in (41b).

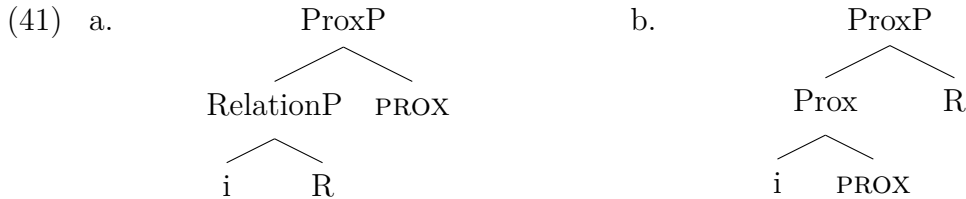

Consider (42), which is felicitous even in a situation where the speaker is gesturing toward his own arm while referring to the location of a mark on another person's arm.

(42) He has a strange mark here [gesture at own forearm].

Importantly, (42) is acceptable in situations where the index is proximal, even if the interpretation is distal, such as when the speaker is discussing an old case or one in which the body is very far away. Therefore, in the locative demonstrative, the proximity information carried by the demonstrative *here* scopes over the index, not R. Adverbial indexicals, in this way, are more similar to nominal demonstratives rather than pronominals (Elbourne 2008).

What about temporal adverbials? Temporal adverbials differ from locatives because it is possible for entities or events to be in different locations, but it is difficult to talk about ‘now’ and mean ‘then’ for someone else. One possible example of this is (43, with thanks to Daniel Harbour).

(43) Napoleon, having defeated the Japanese Armada, now faced a dilemma: to liberate New Zealand from the Tongan yoke or to take Josephine away for a weekend. The summer sales of 1811 decided the matter.

There are also cases in which temporal demonstratives may show deferred reference between different reference times from the perspective of one person, such as the speaker. For instance, a speaker may say (44) at 10 a.m. on December 13. In this case, the adverbial phrase *right now* (underlined) in (44) refers to the proximal speech time but is interpreted as 10 am on December 15.

(44) In two days, I will be in surgery right now.

The statement in (44) may then be interpreted as:

(45) Where the speech time is 10 a.m. on December 13, the speaker will be in surgery at 10 a.m. on December 15.

These examples show that the proximity information contributed by the adverbial demonstrative scopes over the index and not the interpretation.

Rather than calling the morpheme which carries the proximity information *here* or *there*, I refer to this as the demonstrative morpheme, which may be either proximal (PROX) or distal (DIST). This allows the same components to be used across adverbial demonstratives, beyond the locative adverbial.

Assuming that the proximity head scopes over the index, the locative indexical has the syntactic structure (46).

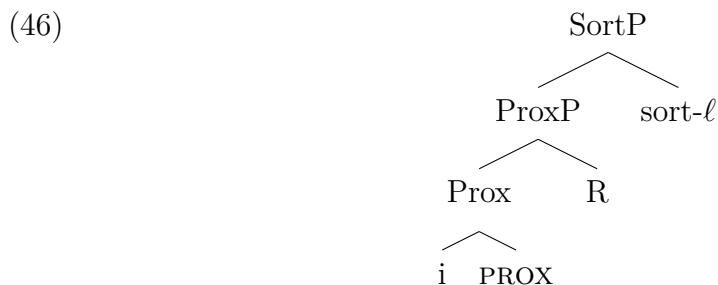

The sort operator then takes, not the index, but its interpretation as the reference object.

Turning back to the example in (37), the adverbial phrase *here* has the following structure. In this situation, the variable assignment function maps the index to the unique empty box in the context.

(47) [SortP [RelationP [ProxP i PROX] R] sort- ℓ]

The demonstrative phrase then has the semantic contribution in (48).⁵

(48) $\lambda e_s. \lambda \ell. \text{EIGEN}(\iota z(z = \text{the empty box in } s \wedge \text{PROX}(\text{the empty box}, a, t)), \ell)$

This means that R relates the index to an entity which is defined only as the unique individual x where it is presupposed that x is in some contextually defined relationship with the empty box. That entity is then the reference object in terms of which the location ℓ is defined.

The lexical entry for the proximity head PROX or DIST in adverbial indexicals differs slightly from the lexical entry for *this* or *that* because locative adverbial phrases do not include an NP component. It would have been possible to incorporate the location semantics into the relation projection, of course, but it would also have been unwieldy. Defining them separately, though, allows us to assume that R has the same semantic contribution for all indexicals. Further, this means that each sort head has the same lexical entry for both indexicals and for PPs.⁶ This will prove useful when extending the analysis to other varieties of indexical.

5. Because the index denotes a definite individual and the relation R also contributes a definite individual z, the semantic contribution of the adverbial demonstrative necessarily includes several definite phrases. This problem is not limited to demonstratives or correlatives. In (i), for instance, the definite DP *the empty box* is embedded inside of the DP *the kitten in the empty box*.

(i) Kimberly laughed at [DP the kitten in [DP the empty box]].

For now, I assume that only the highest definite is interpreted.

6. It is also possible to think of the NP in the demonstrative phrase as analogous to the sort operator in adverbials, where the index is something like the reference object. Elbourne

5.3.3 Other adverbial demonstratives

Throughout this section, I have focused on locative and temporal correlatives and adverbial phrases, concluding that locative and temporal correlatives are actually entities and may enter the syntax as arguments. This approach assumes that all indexicals include an index, analogous to the reference object. Further, all adverbial indexicals will include a proximity head carrying the culturally defined information regarding proximity and other classificatory information, a relation R, and a sort operator which determines which variety of adverbial the phrase will be. It is pretty straight forward to extend the same analysis to the temporal indexicals, for instance, but is it possible to conceive of manner or kind indexicals in the same way?

It is not as much of a stretch as one might suppose to assume that manner adverbials – at least indexical ones like in Hindi, Marwari, and other MIA languages – may take an entity as an argument. In fact, most MIA have very few true adverbial phrases. Generally, adverbial phrases are actually a postpositional phrase, marked as an adverbial by the postposition *se* (Hindi) or *ũ* (Marwari), which take a DP (or possible an NP) as an argument.

- (49) a. [DP *kʰuf*] *se*
 happiness with/-ly
 `happily' [HINDI]
- b. [DP *āʒeldi*] *se*
 speed with/-ly
 `quickly' [HINDI]

In the case of the manner PP, I assume that *se* (which normally marks the source but is also sometimes used as an accusative case marker) is an overt sort head which takes an NP and yields a manner associated with it.⁷

(2008, p. 431), for instance, suggests that ‘we could speak loosely of the ‘referent’ of the demonstrative’, which is along the same lines. But, in order to assume entirely parallel components, the component contributing the proximity information in nominal demonstratives would have to be redefined, and the NP would have to be introduced by some other mechanism. Rather than going to this extreme, I will continue to assume that there are two-part proximity operators in nominal demonstratives and one-part operators in all adverbial indexicals.

7. One question I will not address here is how the manner adverbial enters the syntax. One way to approach this might be to assume a third variety of little p. Another approach might be to make the definition of little p less specific so that it can apply to a wider range

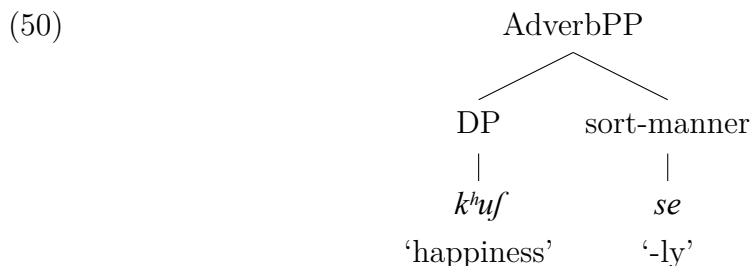

The same manner sort operator will also be a component of the manner indexical, along with the other components of a demonstrative. The Hindi manner indexical *ese* ‘this way, in this manner’ will then have the structure in (51). A similar structure but with a DIST projection would yield *vese* ‘that way, in that manner’.

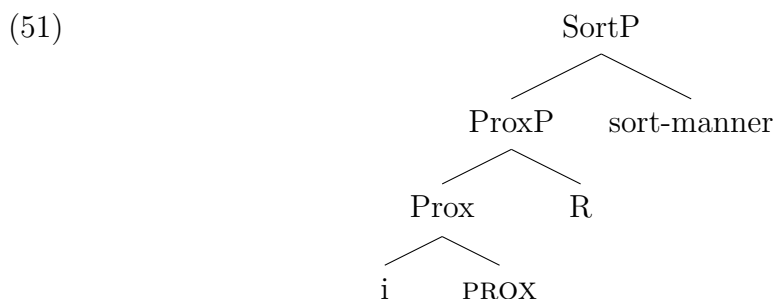

The difference between adverbial indexicals, then, lies in the semantic contribution of its particular Sort head; the ‘flavor’ of the sort head will determine which adverbial demonstrative it is. The sort head then determines the semantic type of the adverbial demonstrative.

This analysis can also be extended to adverbial phrases like *vesa* ‘that kind’ and *utna* ‘that much’ (Hindi). One approach might be to assume that these include a two part proximity head, like the nominal demonstrative *this*, which would then take an NP as its second argument.

(52) $\llbracket \text{this} \rrbracket =$
 $\lambda x_{\langle e \rangle} . \lambda f_{\langle e, \text{set} \rangle} . \lambda g_{\langle et \rangle} . \iota x (f(x) (\lambda e'_{\langle s \rangle} . z)(e) = 1 \wedge g(z) = 1 \wedge \text{PROX}(x, a, t))$

If we were to assume that the linear word order reflects the underlying structure, the NP would scope over the SortP. If the proximity operator is two-part, the computation will not go through.

of adverbials. Either way, it does not affect the analysis of the correlative construction presented here.

Instead, we can only conclude that kind and degree indexicals include the one-part proximity projection, along with the other adverbial indexicals. It must be the sort operator, sort-d or sort-kind, which introduces the NP or AdjP. The lexical entry for sort-d is (53), where EIGEN-DEG is the set of degrees which are associated with the reference object.

$$(53) \quad \llbracket \text{sort-d} \rrbracket = \lambda x. \lambda d. \text{EIGEN-DEG}(x, d)$$

This is just a very general idea of the contribution of the degree indexical. There is probably also a maximality operator built into the definition of EIGEN-DEG, but for now I will just assume that a degree d is analogous to a location which is made up of a set of smaller locations.

Kind adverbials would have a similar semantic contribution except that it is a sort-kind phrase which would take the interpretation and an NP as arguments.

5.4 The adverbial correlative as an index

In Section 5.2 and 5.3, I argued that the adverbial demonstrative includes the same underlying components as adverbial PPs. In summary, a PP denotes a set of vectors which are defined in relation to a location, where that location itself is the eigenspace of a reference object of type e (Zwarts 1997, Zwarts and Winter 2000, Svenonius 2004, 2006, 2008). The SortP may then be embedded underneath of two prepositional phrases, the LocP which defines a location and the VectorP which yields the set of vectors defined by the preposition. The VectorP may enter the syntax through little p (Svenonius 2004, 2008, where little p may either relate locations to events or locations or individuals.

The locative demonstrative is made up of some of the same components as the locative PP but also involves an index when relates to an interpretation through a relation R (Section 5.3). This interpretation, along with the index, is an entity of type e and is analogous to the reference object at the core of the locative PP. The fact that adverbial indexicals take an entity of type e as a reference object corresponds with the properties of the adverbial correlative (Section 5.4) which can only be accounted for if the adverbial correlative is not in fact adverbial but denotes an entity or individual of type e.

If the adverbial correlative construction is really the same construction as the nominal correlative, as argued in Chapter 3, then it follows that the

adverbial relative must also be the overt pronunciation of the index of its correlate. Such an analysis must also account for mismatched correlative constructions and must reflect the fact that adverbial correlative clauses act like nominals rather than adverbials.

In this section, I propose an analysis in which adverbial correlative, which denotes an entity of type *e*, may act as the index of both adverbial and nominal demonstratives. An adverbial correlative construction, therefore, has the structure in 54.

(54)

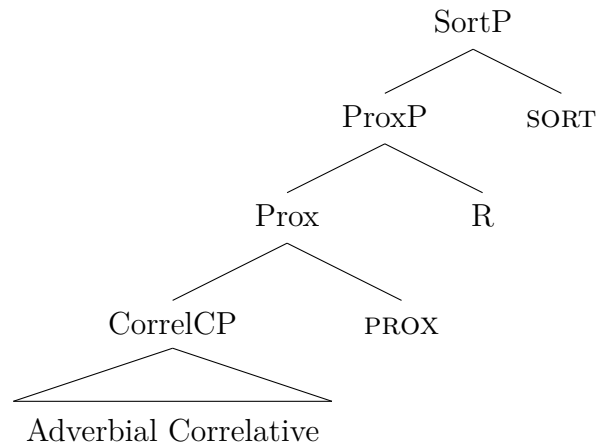

5.4.1 The adverbial correlative construction

The internal structure of the adverbial demonstrative incorporates several of the same components as are found in other adverbial phrases such as adpositional phrases. The structure of a locative PP, for instance, is (55, Zwarts and Winter 2000 and Svenonius 2004, 2010, 2008).

(55)

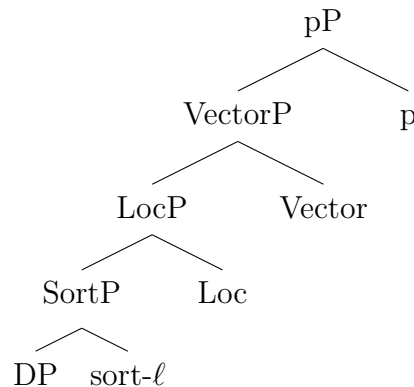

The components of a locative PP include a sort operator which acts as a sortal phrase, taking a DP reference object as an argument and yielding a location, manner, degree, time, etc. The sort- ℓ head, for instance, defines a location in relation to the reference object, where $\text{EIGEN}(x)$ is the region or location that reference object occupies. The PP itself denotes a set of vectors which relate to some point within a location defined in reference to the eigenspace of the reference object.

- (56) $\llbracket \text{SORT} \rrbracket = \lambda x. \lambda z_n. \text{SORT}(x, z_n)$ where SORT is an operator which takes some entity x and gives a region, manner, degree, etc. (n) defined in relation to that object
- $\llbracket \text{sort-}\ell \rrbracket = \lambda x_{\langle e \rangle}. \lambda \ell_{\langle \ell \rangle}. \text{EIGEN}(x, \ell)$
- $\text{EIGEN}(x) =$ the region or location which the reference object occupies
- $\llbracket \text{Loc} \rrbracket = \lambda f_{\langle \ell t \rangle}. \lambda \ell'_{\langle \ell \rangle}. \exists \ell_{\langle \ell \rangle}. f(1) = 1 \ \& \ P(\ell, \ell')$, where P is the property contributed by the Loc adposition.
- $\llbracket \text{Vector} \rrbracket = \lambda f_{\langle \ell t \rangle}. \lambda v_v. \exists \ell'. P(v, \ell') \wedge f(\ell') = 1$ where P is the property contributed by the VECTOR head

The PP then enters the syntax through a little- p projection (Zwarts and Winter 2000, Svenonius 2004).

- (57) $\llbracket p_{\text{event}} \rrbracket = \lambda f_{\langle v, st \rangle}. \lambda e_s. \exists v. f(v) = 1 \wedge \text{LOC}(e, v)$
- $\llbracket p_{\text{entity}} \rrbracket = \lambda f_{\langle v, et \rangle}. \lambda x_e. \exists v. f(v) = 1 \wedge \text{LOC}(x, v)$

Importantly, extending this analysis to other types of adverbial phrases means that all prepositional phrases are defined in reference to some object. The adverbial demonstrative, which also includes a sort-phrase, is similarly defined in terms of a reference object, but in this case the reference object is an index which normally gets its meaning through variable interpretation.

All demonstrative phrases include (58) as part of their structure. The proximal phrase contributes an individual which is taken as the reference object of the sort phrase. This individual is analogous to the interpretation of the nominal demonstrative.

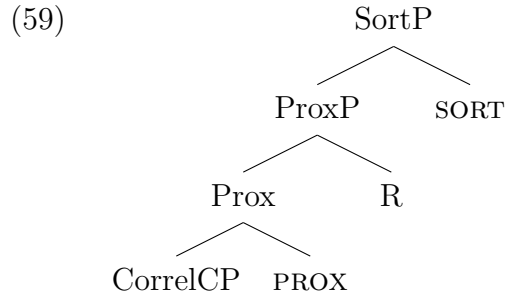
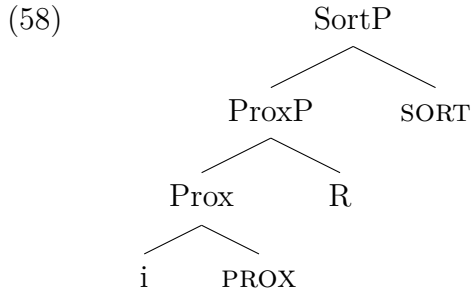

In the correlative construction, the adverbial demonstrative takes a correlative CP as its index, as shown in (59). To illustrate this, consider example (60).

- (60) [CorrelCP $\widehat{d\bar{z}\bar{a}t^h e}$ $b^h i\bar{r}$ $r\bar{e}v e$] $t\bar{j}^h o r o$
where_{RC} crowd.F stay.IMPV.PRS.3.SG boy.M.SG
 $b^h \bar{a}t e$ $\widehat{d\bar{z}\bar{a}v e}$
there go.IMPV.PRS.M.SG

'Where a crowd gathers, (the) boy always goes there.' [MARWARI]

The adverbial correlate $b^h \bar{a}t e$ 'there' has the structure in (61), including a sort-phrase to locations (sort- ℓ) and a distal operator (DIST_{simplex}).

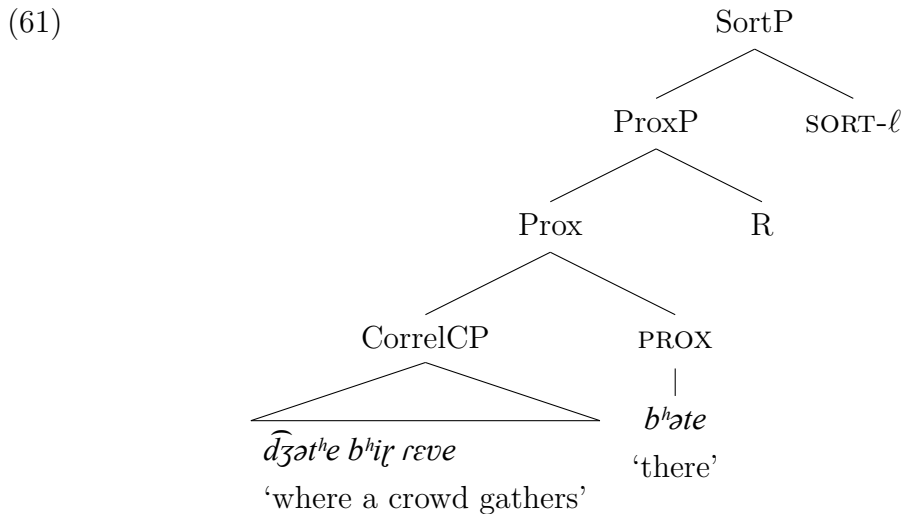

For now, I assume that the semantic contribution of the correlative $\widehat{d\bar{z}\bar{a}t^h e}$ $b^h i\bar{r}$ $r\bar{e}v e$ 'where a crowd gathers' is (62).

- (62) $\iota a_{\langle e \rangle} (\exists e'_{\langle s \rangle} . \exists \ell_{\langle \ell \rangle} . a \text{ crowd gathers } (e') \wedge \text{location}(e', \ell) \wedge \ell \text{ is the eigenspace of } a)$

I argued in Chapter 4 that the correlative itself is an individual of type e and does not act as an adverbial phrase. How an adverbial correlative gets a type e interpretation will be looked at in depth in Chapter 6.

The proximity head $\text{DIST}_{\text{simplex}}$ and the relation R have the same semantic contribution in the correlative construction as they do when the index is covert.

$$(63) \quad \llbracket \text{DIST}_{\text{simplex}} \rrbracket \\ = \lambda x_{\langle e \rangle} . \lambda f_{\langle se, st \rangle} . \lambda e_{\langle s \rangle} . \iota z (f(x)(\lambda e'_{\langle s \rangle} . z)(e) = 1 \wedge \text{DIST}(x, a, t))$$

$$(64) \quad \text{Where } R \text{ is an identity relation,} \\ \llbracket R \rrbracket = \lambda y_{\langle e \rangle} . \lambda x_{\langle s, e \rangle} . \lambda s_{\langle s \rangle} . x(s) = y$$

The $\text{DIST}_{\text{simplex}}$ operator takes the correlative clause as its first argument. In this example, R is an identity relation. The place where the crowd gathers and the place the boy goes are the same. The contribution of the correlative-correlate constituent, then, is (65).

$$(65) \quad \lambda e . \exists \ell' . \text{EIGEN}(\iota a (\exists e'_{\langle s \rangle} . \exists \ell_{\langle \ell \rangle} . a \text{ crowd gathers } (e') \wedge \text{location}(e', \ell) \\ \wedge \ell \text{ is the eigenspace of } a), \ell')$$

Similarly, kind and degree indexicals include the one-part proximity projection. It must be the sort operator, sort-d or sort-kind, which introduces the NP or AdjP. Like the locative sort operator, the degree and kind sort operators will define a degree or kind defined in relation to their NP/DP argument. The lexical entry for sort-d, therefore, is (54), where EIGEN-DEG is the set of degrees which are associated with the reference object.

$$(66) \quad \llbracket \text{sort-d} \rrbracket = \lambda x . \lambda d . \text{EIGEN-DEG}(x, d)$$

This is just a very general idea of the contribution of the degree indexical. There is probably also a maximality operator built into the definition of EIGEN-DEG , but for now I will just assume that a degree d is analogous to a location which is made up of a set of smaller locations.

Kind adverbials would have a similar semantic contribution except that it is a sort-kind phrase which would take the index and an NP as arguments.

The availability of mismatched correlative constructions (see Chapter 3) follows naturally from this analysis. In (67), the nominal correlative *dziko munak gave* ‘which man is singing’ relates to an degree demonstrative *ut:o* ‘that

much'. The degree to which Raam wants to sing well, therefore, is defined in relation to the man who is singing.

- (67) [CorrelCP *dziko minak gave*] *ram ut:o id̃z*
 which man sing.IMPV.PRS.3 Raam that.much only
hakro gavə-ŋi t̃fave
 good.M.SG sing-INF want.IMPV.PRS.3

'Raam wants to sing as well as the man who is singing.'

Lit.: 'Which man is singing, Raam wants to sing that well.' [MARWARI]

The nominal correlative-adverbial correlate constituent has the structure (68).

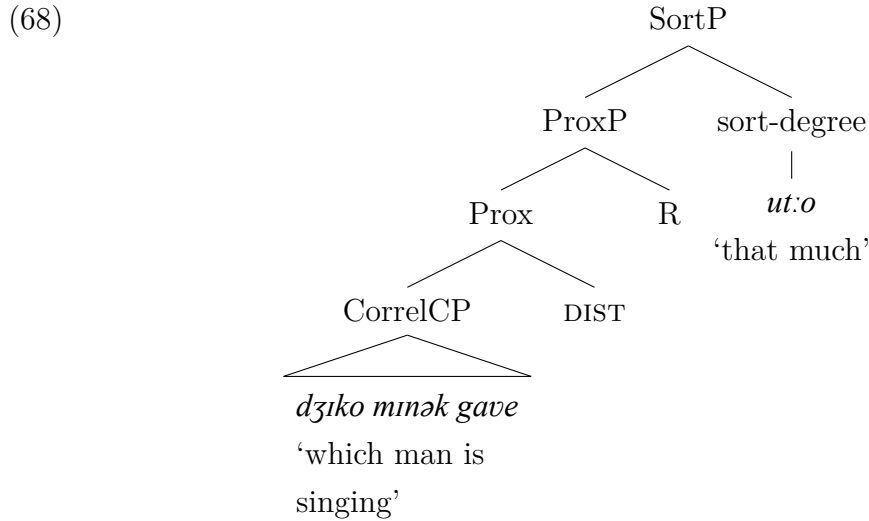

It is also possible for an adverbial correlative to be the overtly pronounced index of a nominal demonstrative phrase. An example of this is (69) in which the correlative *ḍzahã rohit kam karta he* 'where Rohit works' relates to the demonstrative phrase *vo dukan* 'that restaurant'.

- (69) [*ḍzahã rohit kam karta he*] **(vo) dukan*
 where Rohit work do.IMPV.M.SG PRS.3.SG that shop.M.SG
pehele at̃ʰa restrant t̃ʰa (lekin ab̃i nuhĩ)
 before good.M.SG restaurant.M.SG be.PST.M.SG but now NEG

'Where Rohit works, that shop used to be a good restaurant (but now it is not).'

[HINDI]

In this construction, the adverbial correlative is acting as the (nominal) index of the demonstrative phrase. (69), then, has the structure in (70).

(70)

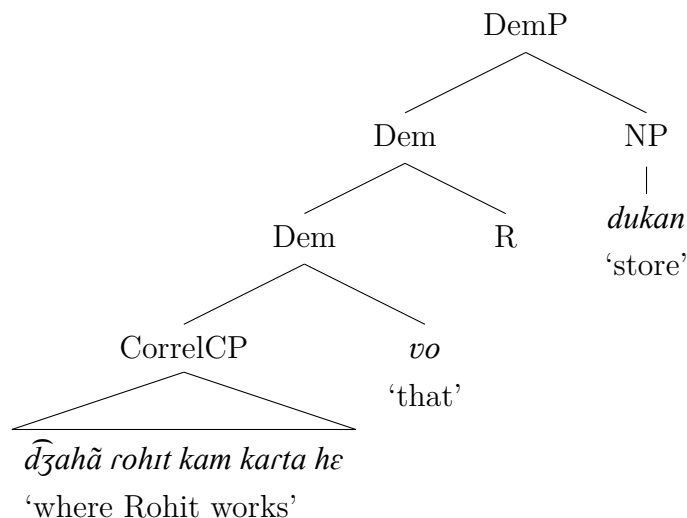

While the adverbial correlative is headed by an adverbial wh_{RC} , it actually denotes an entity of type e and enters the syntax as a nominal phrase, as argued in Chapter 4. For this reason, the adverbial correlative can enter the syntax as the index of either a nominal or adverbial demonstrative, and vice versa.

The interpretation of mismatched correlatives and adverbial correlatives does not involve any additional mechanisms other than those already found within the internal structure of adverbial and nominal demonstratives. The correlative itself is simply an overt pronunciation of the index of the demonstrative.

5.4.2 Deferred Reference in Adverbial CorrelCPs

In Chapter 3, Section 3.5, I showed that deferred reference is possible in nominal correlatives even if there are some restraints. This is evidence that the correlative clause is, in fact, an overt pronunciation of the indexical projection within the syntax. Deferred reference is similarly available in adverbial correlative constructions. An example of this is (71, repeated from 154). Suppose that a group of friends has gone on a camping trip near Spiti, a popular tourist destination in the Himalayas. On returning, one of the group finds that he has lost his wallet. He then makes the following statement:

- (71) [*d̥ʒəde ap:a spiti re kəne d̥ɛɾo lagaijo*] *m̄*
 when we.INCL Spiti near camp.PFV.M.SG I
 {*utʰe* / *un d̥ʒəge* *m̄*} *maro bətuʔa gəmo*
 there / that.OBL place.OBL.M.SG in my.M.SG wallet lose.M.SG
diyo
 give.LGT.PFV.M.SG

‘When we camped near Spiti, I lost my wallet {there/at that place}.’

[MARWARI]

In this case, *d̥ʒəde ap:a spiti re kəne d̥ɛɾo lagaijo* ‘when we were camping near Spiti’ may either refer to the dates when the group was in Spiti, for example May 15-20, or it may be interpreted as something like ‘the occasion of our going camping near Spiti.’ The interpretation of *utʰe* ‘there’ or *un d̥ʒəge m̄* ‘at that place’ is the campground they stayed at during their holiday, where the relation R is ‘the place they stayed at during their trip.’ Importantly, the index of the demonstrative cannot be Spiti itself because the group was not camping in Spiti but near it.

While a mismatched correlative like (71) can display deferred reference, one must be careful not to assume that all mismatched correlative constructions involve deferred reference. Where a locative correlative is the argument of a DemP, as in (72), it might at first seem like this is a case of a location being interpreted as an object.

- (72) [*d̥ʒahā əmbər kam kərta* *he*] *vo rɛstɔrənt*
 where Amber work do.IMPV.M.SG PRS.3.SG that restaurant.M.SG
ətʃʰ:a he
 good.M.SG be.PRS.3.SG

‘Where Amber works, that restaurant is very good.’

[HINDI]

A locative correlative, though, does not denote a location but an individual which is the reference object of a location. To illustrate this, let’s say that Amber works at Karim’s, one of my favorite restaurants in Old Delhi. The entity referred to by the correlative is not the location ‘16 Matia Mahal Bazar, near Jama Masjid,’ where Karim’s is located; the correlative refers to Karim’s itself.⁸ Thus, the meaning of the index is effectively Karim’s, which is also the

8. In fact, even if Karim’s were to relocate and retain Amber as an employee, (72) can still

interpretation of the demonstrative phrase *vo restaurant* ‘that restaurant.’ While there is a mismatch between the variety of the correlative and the variety of the demonstrative, this is not an example of deferred reference.

5.5 Conclusion

If the adverbial correlative is a true correlative, then it follows that it will have the same syntactic structure as the nominal correlative, which proves to be the case.

The adverbial correlate is an indexical, where the index is analogous to the reference object of other adverbial phrases such as locative PPs (following Zwarts 1997 and Zwarts and Winter 2000). Just as an adpositional phrase such as ‘in the house’ is defined reference to an object (in this case, ‘the house’), the adverbial demonstrative is defined in terms of an object. The adverbial correlative, which denotes an entity of type e , is the spell-out of the index of the adverbial demonstrative.

The availability of deferred reference in adverbial demonstratives shows that they are indexicals, and that like the nominal demonstrative, there is an indexical projection and a relation R projection within the syntax of the demonstrative. The availability of deferred reference in adverbial correlatives, while limited, is evidence that the adverbial correlative is an overt spell-out of the index.

A direct consequence of this analysis is the availability of mismatched correlative constructions in which an adverbial correlative corresponds to a nominal demonstrative in the main clause, and vice versa. This apparent mismatch is easily accounted for under an analysis in which all indices denote entities of type e , and it is the sort-phrase which gives the demonstrative its adverbial interpretation.

be true.

Chapter 6

The structure and meaning of single headed correlatives

6.1 Introduction to the Analysis

Thus far, I have limited the discussion of the correlative to the relationship between the correlative and the indexical correlate. In Chapters 3 and 5, I showed that the correlative clause enters the syntax as an argument of the indexical. Further, the adverbial correlative, like the nominal correlative, denotes an individual of type e and is not, in fact, an adverbial phrase at all (Chapter 4). This means that all indexicals, regardless of what variety they are, take a unique individual as their index.

In this chapter, I turn to the structure and meaning of correlative itself – the single-headed correlative (SHC) in particular. Here, I will look more closely at the semantic contribution of the SHC and its syntactic structure. Chapter 7 will look more closely at the multi-headed correlative construction.

Section Section 6.2 focusses on the semantic contribution of the SHC and its role as a definite description. Previous research has focussed on the unique or, as it is sometimes called, the maximal interpretation of the correlative (Section 6.2.2). I summarize arguments from Dayal (1996) that the correlative clause involves uniqueness effects. Then, in Section 6.2.3, I provide new data which shows that the correlative carries a presupposition of both uniqueness and existence. I propose that there is a Q particle, Q_{COR} , which gives the correlative its definite interpretation.

In Section 6.3 of this chapter, I show that the relative pronoun (wh_{RC})

of the correlative is a *wh*-element along with features similar to interrogative *wh* (wh_Q). Because the wh_{RC} is a *wh*-element, an analysis of the correlative clause can then pull from previous research on the semantics of questions, free relatives, etc., and other clauses which involve *wh*-elements.

One of the questions which the *wh*-ness of the relative pronoun will raise is where the wh_{RC} is interpreted. While previous analyses assume that the wh_{RC} -phrase raises to Spec-DP at LF, this leads to problems for the interpretation of the adverbial correlative. I take an alternative approach to the composition of the wh_{RC} -phrase based on Cable (2010)'s and Kotek (2014)'s analysis of questions. I assume that the wh_{RC} -phrase remains in-situ, but the wh_{RC} -phrase itself includes a relativizing Q particle, Q_{COR} , which raises from inside the wh_{RC} -phrase to Spec,CP to give the clause its correlative interpretation. The wh_{RC} -phrase is then interpreted in-situ but the interpretation of the correlative as a whole comes from the movement of Q_{COR} and the trace that it leaves.

Finally, in Sections 6.4 and 6.5, I show how this analysis applies to nominal and adverbial correlatives and what implications this has for the syntactic structure of the correlative clause.

Many authors have noted that the correlative is the remarkably similar to the free relative, particularly with respect to their semantic contribution. While Bhatt (1997, 2003) assumes that correlatives are, in fact, free relatives, Dayal (1996), Butt and Deo (2005), and Citko (2009), among others, argue that the correlative cannot be a free relative because of their apparent syntactic differences, particularly the demonstrative requirement. For now, I follow Bhatt (2003) in assuming that correlatives are, in fact, free relatives.

6.2 The correlative as a definite description

It is well established that the interpretation of the correlative clause is distinct from other relativizing structures such as postnominal relative constructions. In particular, the correlative clause, like a free relative, has the semantic contribution of a definite description (Srivastav 1991; Dayal 1996, Ch. 7; Grosu and Landman 1998; Bianchi 2002a,b). Not only does the correlative denote an individual, but it refers to an individual which is presupposed to both exist and to be unique.

In Section 6.2.1, I discuss the definition of definiteness used in this analysis. Definiteness involves two presuppositions. First, a definite carries a presuppo-

sition that there is an individual as described by the content and that there is exactly one such individual. Section 6.2.2 shows that the correlative denotes a unique individual. This contribution has previously been referred to as maximality or exhaustivity. In Section 6.2.3, I present new evidence from Marwari which shows that correlatives also carry an existence presupposition.

6.2.1 A formal definition of definiteness

Throughout this discussion, I assume a Fregean (or Frege-Strawson) theory of definiteness in which definite descriptions are referential and introduce a presupposition that there is a unique individual which satisfies the nominal descriptive content (Frege 1882; Strawson 1950; Heim 1991; Elbourne 2005, 2008, 2013). Definite descriptions, therefore, are formed by combining a singular definite article with expressions that denote concepts – in effect, NPs. When there is exactly one object or individual which is within the set defined by the concept, the definite description refers to that object. The requirement that there is one, and only one object, which fulfills the context or satisfies the NP restrictor is what is known as the *uniqueness condition*.

Other approaches to definiteness assume that definite descriptions introduce a presupposition that their antecedent is a Heimian discourse referent that is familiar in the context (Heim 1982; Roberts 2003). The Fregean approach differs from this in that it does not assume that the referent is familiar but only that the speaker assumes the hearer will accept the presupposition. Thus, the referent does not have to have appeared previously in the discourse or already be established within the context.

A definite description, then, carries a presupposition that there is an individual as described by the content and that there is exactly one such individual. The lexical entry for a definite article is (1).

- (1) [[the]]
 $= \lambda f_{\langle et \rangle} . \text{there is exactly one } x \in C \text{ such that } f(x)=1 . \iota y (y \in C \wedge f(y)=1)$

The iota notation ι will be used as follows: given the expression in (2), if (2) is defined, the denotation of the expression is the unique individual which fulfills the property or descriptive content contributed by the function $f(x)$, where x individual is of type e (Elbourne 2013).

(2) $\iota x(f(x) = 1)$

The expression (2) is defined if there is exactly one entity y such that $f(y) = 1$, in which case ιx will be that individual. If there is no such individual or if there is more than one, the whole expression is undefined and will have no semantic value. That is, if there is no unique individual in the situation with the property contributed by the descriptive content, there is a presupposition failure.

How does this apply to the correlative? If a correlative clause such as $\widehat{d}\bar{z}o\ l\bar{a}rki\ k^h\bar{a}r\bar{i}\ h\bar{e}$ ‘which girl is standing’ is a definite description, then the denotation of the correlative must include a presupposition that there is an individual who is both a girl and who is standing, and that this individual is the only girl who is standing.

(3) $[_{\text{CorrelCP}}\ \widehat{d}\bar{z}o\ l\bar{a}rki\ k^h\bar{a}r\bar{i}\ h\bar{e}\]\ vo\ l\bar{a}mbi$
which girl.F.SG standing.F.SG be.PRS.3.SG that tall.F.SG
h\bar{e}
be.PRS.3.SG

‘Which girl is standing, that/she is tall’ (*from Dayal 1996, p. 152*) [HINDI]

Not all accounts of definiteness assume that there is a uniqueness requirement. While Frege and Strawson are largely in agreement in their approach, Strawson’s views differ from Frege’s in that Strawson does not assume a uniqueness condition as a requirement for definiteness (Elbourne 2013). Instead, ‘Strawson is adamant that definite descriptions could be used quite successfully when more than one object fell under the relevant concept’. For example, (4) is clearly felicitous in any number of situations, even when there is clearly more than one table in the world.

(4) The table is covered in books.

As Elbourne (2013) points out, the problem with (4), which may be called an *incomplete definite description*, is a particular case of the larger problem of *implicit content* (an idea suggested by Neale 1990). Implicit content is content which is not explicit but which seems to be more a part of the assertion made by a sentence than, say, an implicature does. (5a) and (5b) are examples of sentences which are said to exhibit implicit content.

- (5) a. Everyone was sick.
b. It's raining.

In (5a), originally from Neale (1990), *everyone* may refer to ‘everyone who attended karaoke night at the Leyton Star’. Similarly, (5b), originally from Perry and Blackburn (1986) may be interpreted as ‘raining in Mile End’, where Mile End happens to be the location of the speaker at the time of utterance.

Various approaches have been proposed to account for implicit content, varying in whether the implied content is part of the denotation of the sentence or not. Elbourne (2013) adopts an approach in which implicit content is provided by predicates being associated with a situation variable in the syntax (Kuroda 1982; Recanati 1996; Kratzer 2004). Different predicates in one sentence can be evaluated with respect to different situations, where situations are subparts of the relevant world. While Elbourne (2013) assumes that the situation is an argument of the definite article just as the NP is, I will simply stipulate that the uniqueness of an individual refers only to its uniqueness within the relevant, minimal situation and does not imply that it is the only relevant individual in the real world or any larger situation.

The uniqueness of an individual with respect to a situation is important for deriving the single and universal reading of the correlative. The singleton reading is relevant with respect to a specific situation or context where a universal reading applies across situations where there may still be only one individual within each situation which is defined by the concept contributed by the NP. Plural *wh*_{RC}-phrases denote plural individuals whose members are not directly accessible to the matrix clause (Link 1983).

Many authors have discussed the correlative as denoting a unique or maximal set of individuals (Section 6.2.2). The fact that the correlative carries a presupposition of uniqueness and existence is more difficult to demonstrate, and is something which few authors have discussed. In Section 6.2.3, I present new data which shows that the correlative does not just refer to a unique individual or set of individuals but in fact carries a uniqueness presupposition. Section 6.2.4 briefly discusses a similar analysis of free relatives in English. Caponigro (2003) has shown that English free relatives have the semantic denotation of plural definite descriptions.

6.2.2 Maximality/uniqueness in correlatives

Several authors have pointed out that the correlative contributes a different semantics than other relativizing structures (cf. Srivastav 1991; Dayal 1996; McCawley 1994; Grosu and Landman 1998). These authors have argued that the correlative clause must refer to all of the individuals who have the property described by the content of the clause. This characteristic has been called different things – maximality, exhaustivity, uniqueness – all of which reflect that the correlative must pick out the entire set of individuals who have the property described by the correlative clause. In this way, the correlative is distinct from other relativizing structures such as a DP modified by a postnominal relative clause, which does not display uniqueness or maximality effects.

Dayal (1996) argues that correlatives are definites and display uniqueness effects just as free relatives and internally headed relatives do. The correlative clause must refer to all the individuals in a situation which have the properties defined by the correlative CP. Consider the correlative constructions in (6a) and (6b).

- (6) a. [$\widehat{d}\text{ʒo}$ $l\text{ə}rki$ $k^h\text{ə}r\text{i}$ $h\text{e}$] vo $l\text{ə}mbi$
 which girl.F.SG standing.F.SG be.PRS.3.SG that tall.F.SG
 $h\text{e}$
 be.PRS.3.SG
 ‘Which girl is standing, that is tall.’ (from Dayal 1996, p. 196) [HINDI]
- b. [$\widehat{d}\text{ʒo}$ $l\text{ə}rki$ $k^h\text{ə}r\text{i}$ $h\text{e}$] vo $l\text{ə}rki$ $l\text{ə}mbi$
 which girl.F.SG standing.F.SG be.PRS.3.SG that girl.F.SG tall.F.SG
 $h\text{e}$
 be.PRS.3.SG
 ‘Which girl is standing, that girl is tall.’ (from Dayal 1996, p. 196) [HINDI]

The sentences in (6a) and (6b), Dayal points out, are semantically equivalent. Both sentences may be interpreted to mean ‘the unique individual who is a standing girl is tall.’

While very similar, (7) has slightly different truth conditions (Dayal 1996).

- (7) [$\widehat{d}\widehat{z}o$ $k^h\widehat{a}ri$ he] vo $l\widehat{a}rki$ $l\widehat{a}mbi$ he
 which standing.F.SG be.PRS.3.SG that girl.F.SG tall.F.SG be.PRS.3.SG
 ‘Which is standing, that girl is tall.’ (from Dayal 1996, p. 196) [HINDI]

Like (6a) and (6b), (7) seems to mean that ‘the unique standing girl is tall’. A more accurate interpretation of (7) would be ‘the unique girl, who is the unique individual in the context who is standing, is tall’. That is, both (6a) and (6b) are felicitous in situations where multiple people are standing, as long as only one of those people is a girl. In (7), because there is no NP restriction in the relative phrase, the correlative must refer to all of the people who are standing. (7) is only felicitous in a situation where only one person is standing. Uniqueness, then, does not only come from the meaning of the demonstrative but from the correlative clause.

It is the correlative itself which contributes the uniqueness interpretation. This can be seen in (8).

- (8) [$\widehat{d}\widehat{z}o$ $l\widehat{a}rka$ $k^h\widehat{a}ra$ he] vo $\widehat{i}\widehat{f}atr$ tez
 which boy standing.M.SG be.PRS.3.SG that student quick
 he
 be.PRS.3.SG

- ‘Which boy is standing, that student is smart.’ (from Dayal 1996, p. 196) [HINDI]

The statement in (8) is felicitous even where there are multiple students present in the situation, and $\widehat{i}\widehat{f}atr$ ‘student’ can refer to both boys and girls in the class so there is no interference from gender agreement on the verb or adjective. It can, therefore, only be the correlative which is contributing the uniqueness interpretation.

Marwari correlatives have the same restriction. The Marwari correlative construction in (9) is grammatical but is unacceptable in a situation where there are multiple girls sitting at the bus stop.

- (9) [*d̥ʒiki* *t̥ʃori bɛtʰi* *hɛ*] *va* *bəs ri*
 which.F.SG girl sitting.F.SG be.PRS.3.sg that.F bus of.F.SG
baʃ *d̥ʒave*
 waiting go.IMPV.PRS.3

‘The girl who is sitting down is waiting for the bus.’

Lit.: ‘Which girl is sitting, that is waiting for the bus.’ [MARWARI]

Dayal (1996) compares her analysis of correlatives to Jacobson (1995)’s analysis of free relatives in English. Like correlatives, a free relative can only refer to all of the members of a set. For example, Jacobson compares the semantic contribution of the free relative (FR) in (10a) to the contribution of the definite DP in (10b).

- (10) a. I didn’t like [_{FR} what Beatrice ordered].
 b. I didn’t like [_{DP} the things Beatrice ordered].

Neither of the statements in (10) can be continued with, ‘... but I liked most of them.’ Similarly, the Hindi sentence in (11) does not allow such a continuation, either.

- (11) [*d̥ʒo* *t̥ʃiz̥* *ənu ne m̥əŋgaj̥*] *ve* *mud̥ʒʰe nəh̥*
 which things.M.PL Anu ERG order.PFV.F.PL those I.DAT NEG
pəsənd aj̥
 liking come.LGT.PFV.F.PL

‘Which things Anu ordered, I didn’t like them.’ (*from*:

Dayal 1996, p. 213) [HINDI]

The reading of the correlative and free relative is distinct from the contribution of a universal quantifier, as well. Unlike (10a) and (10b), (12) can be continued with ‘... but I liked most of them.’¹

- (12) I didn’t like [everything Beatrice ordered].

Dayal (1996) argues that the correlative clause shows uniqueness effects. But, while Dayal concludes that correlatives are definite, the examples she presents do not show that uniqueness is presupposed. Similarly, Grosu and Landman (1998), conclude that correlatives, along with other internally headed

1. For some speakers, (12) is better if continued with ‘but I liked most of it.’

relative clauses, are maximal constructions (i.e., unique) but do not go as far as to conclude that correlatives have the semantic contribution of a definite.

In the next section, I present new data from Marwari which shows that correlatives do in fact carry a uniqueness presupposition.

6.2.3 Correlatives carry a uniqueness presupposition

In Section 6.2.1, I defined a definite individual as an individual which is presupposed to be both unique and to exist. It is well established that a nominal correlative clause denotes a unique individual or unique plural individual, as illustrated in Section 6.2.2. Uniqueness or maximality effects in correlatives, though, do not necessarily require that uniqueness be presupposed.

In the first test, consultants were shown a drawing of a family scared of a sound coming from a bush and asked whether the following statement is *həʃi ja dʒʰut* ‘truth or falsehood’.

- (13) [*dʒəko* *fer* *dʒʰadija* *mẽ he*] *har ek*
 which.M.SG tiger bush.OBL.M in be.PRS.3.SG each one
 mʰanko *un-ũ* *dəre*
 person.M.SG that-from be.scared.PFV.M.PL

‘Every one of them was scared of the tiger in the bush.’

Lit.: ‘Which tiger is in the bushes, every person is scared of that.’

[MARWARI]

Whether (13) is acceptable or not depends on the respondent’s willingness to accept the presupposition that it is a tiger which is making the noise. One respondent said that this was clearly true because, ‘Everyone knows that that kind of voice coming from a bush is a tiger.’ Others argued that it must be false because, ‘How can we know that it is a tiger? It could be something else.’ Both responses indicate that there is a presupposition here, one which some speakers are willing to accommodate and some speakers are not.

Matthewson (2004) and von Stechow and Matthewson (2008) suggest several ways to test for presuppositions in an unfamiliar language.² One indication that a construction includes a presupposition is the ‘Can I start a story this way?’ test. After translations all of the sentences in the story, I returned to

2. For the full story used for testing presuppositions and the suggested changes, see Appendix C.

the first few sentences, in (14), and asked the Marwari speakers, ‘Can I start a story this way?’

- (14) a. *ek dɪn ek tʃʰoto gaõ ho dʒɪm:õ*
 one day one small.M.SG village.M.SG be.PRS.3.sg which.OBL-OF.M.SG
nam sangəria ho
 name.M.SG Sangaria be.PRS.3.SG

‘One day, there was a small village called Sangaria.’ [MARWARI]

- b. [*dʒɪko mɪnək sarechã ã aijo ho*]
 which man.M.SG Sarechan from come.PFV.M.SG PAST.M.SG
vo apre pərivar re hatʰe pa|a-pa|a dʒaũto
 that.M.SG own family.OBL with on.foot-REDUP go.IMPFV.M.SG

‘The man from Sarechan was walking along with his family.’

Lit.: ‘Which man came from Sarechan, he was going on foot with his family.’ [MARWARI]

The Marwari speakers agreed that this is not a good way to start a story and said that (14) should be changed to (15) in order to be felicitous.

- (15) *ek mɪnək sarechã ã aijo ho*
 one man Sarechan from come.PFV.M.SG PAST.M.SG

‘A man from Sarechan came along.’ [MARWARI]

Another test of presuppositions is testing for the felicity of a wait-a-minute response (Matthewson 2006). Consultants found it felicitous for a character to challenge the presupposition assumed by another character. For instance, in a situation where a family, including a brother and sister, is considering a noise coming from a bush. All three Marwari speakers agreed that, if the boy points to the bush and says (16a), it is felicitous for his sister to respond with (16b).

- (16) a. *tʰoro kaijo* [*ḍʒako fer babulija mē*
 boy.M.SG say.PFV.M.SG which tiger bushes.OBL in
hε] *vo heṅə-ne kʰaji ḍʒaji*
 be.PRS.3.SG that.M.SG all-ACC eat go.LGT.FUT.F.SG

‘The boy said: The tiger in the bushes will eat us all!’

Lit.: ‘The boy said: Which tiger is in the bush, that will eat us all!’

[MARWARI]

- b. *tu kɪkar ḍʒaṅe hε ke vo ek*
 you how_Q know.INF be.PRS.3.SG COMP that.M.SG one
fer hε
 tiger be.PRS.3.SG
ho səkε ke vo bandro hε
 be able.SUBJ COMP that.M.SG monkey.M.SG be.PRS.3.SG

‘How do you know that it is a tiger? It’s possible that it’s a monkey.’

[MARWARI]

All of my consultants agreed that (16b) is a felicitous continuation of (16a), indicating that the correlative *ḍʒako fer babulija mē hε* ‘which tiger is in the bushes’ presupposes that what is in the bush is a tiger.

Taken individually, the responses to each one of these ways of testing for a wait-a-minute response is an indication that the correlative construction carries a presupposition. Together, the fact that all three methods indicate that the correlative can evoke a wait-a-minute response is strong evidence that a correlative includes a presupposition which may be challenged.

6.2.4 Correlatives are definite descriptions

In the first part of this section (Section 6.2.1), I said that, if a correlative clause such as *ḍʒo ləṅki kʰəṅi hε* ‘which girl is standing’ is a definite description, then the denotation of the correlative must include a presupposition that there is an individual who is both a girl and who is standing, and that this individual is the only girl who is standing.

- (17) [_{CorrelCP} *d̄ʒo lərki kʰəɽi he*] *vo ləmbi*
which girl.F.SG standing.F.SG be.PRS.3.SG that tall.F.SG
he
be.PRS.3.SG

‘Which girl is standing, that/she is tall’ (from Dayal 1996:152) [HINDI]

McCawley 1994, Dayal (1996), Grosu and Landman (1998) all conclude that the correlative does display uniqueness effects. The correlative *d̄ʒo lərki kʰəɽi he* ‘which girl is standing’ is only felicitous in a situation where there is exactly one girl who is standing.

The second aspect of a definite description is that the uniqueness of the individual referred to must be presupposed. That is, that there is a girl who is standing must be part of what is taken for granted when determining the truth value of (17). Using methodology outlined by Matthewson (2006), I presented new data from Marwari which shows that the correlative does, in fact, carry a uniqueness presupposition. The correlative *d̄ʒo lərki kʰəɽi he* in (17), therefore, does not simply assert that there is a girl who is standing but asserts that there is a single, presupposed standing girl.

From these facts, we can conclude that the correlative refers to a unique, presupposed individual within the context. The correlative clause, therefore, has the semantics of a definite description.

6.3 The relative pronoun as a *wh*-element

In this section, I look at what it means for the correlative to include a *wh*-element. While the discussion in this section is largely focused on syntactic considerations, the syntactic analysis presented here will have important implications for the semantics of the correlative clause as a whole (Section 6.4 and Section 6.5). It is not strictly necessary for an analysis of the correlative to link it to other *wh*-clauses such as free relatives and interrogatives, but it is useful because many of the questions related to the correlative have already been addressed in relation to other *wh*-constructions. This allows us to pull from previous analyses and to apply those approaches to the correlative.

It is not a new idea, of course, to consider the relative pronoun a *wh*-element. Many authors have treated the fronting of the *wh*_{RC}-phrase in correlatives (whether covertly or overtly) as *wh*-movement in questions (including

but not limited to Dayal 1996, p. 188; Ivzorski 1996, p. 13; Safir 1999, p. 599-600; Sauerland 2000, p. 3-5). Still others have described the fronting of the wh_{RC} as A'-movement without actually referring to it as wh -movement. Dwivedi (1994, p. 94), for instance, notes in a footnote that ‘[$\widehat{d}\mathfrak{z}o$ ‘which’] is an operator that moves to an A' position from its IP internal position and binds a trace created by this movement.’

In order to talk about correlatives, questions, and similar constructions, in this section and throughout the chapter I will occasionally refer to wh -clauses. By wh -clause, I refer to finite clauses which include a wh -element and whose overall meaning comes from the wh -phrase. This will include constructions like questions, embedded questions, free relatives, correlatives, and internally headed free relatives.

Section 6.3.1 summarizes the various wh -elements in Hindi and Marwari, including wh_{RCS} and wh_{QS} , and shows that they are phonologically and, probably, morphologically related.

Section 6.3.2 show that the wh_{RC} -phrase in Hindi, Marwari, and other Modern Indo-Aryan languages may remain in-situ just as the wh_Q -phrase does. Because these languages are in-situ, this will give rise to the question of where the wh_{RC} -phrase is interpreted. I propose that the wh_{RC} -phrase is interpreted in-situ but, inspired by Cable (2010) and Kotek (2014)’s analyses of questions (Section 6.3.3), assume that the relative phrase include a Q particle Q_{COR} which raises to Spec-CP at LF to give the clause its correlative interpretation (Section 6.3.5).

6.3.1 Morphological similarity between wh -elements

In a language like English, in which the relative pronoun and the corresponding wh_Q are homophonous, it is fairly transparent to think of them both as wh -elements. In MIA languages like Marwari and Hindi, the wh_{RC} is generally similar to but distinct from the wh_Q .

Looking at the full paradigm of wh_{QS} and wh_{RCS} in Hindi and Marwari, there is a clear pattern: all relative pronouns except the nominal wh_{RC} are similar to the interrogative wh except that wh_{RCS} begin with $/\widehat{d}\mathfrak{z}/$ and wh_{QS} begin with $/k/$ ($/\widehat{d}\mathfrak{z}/$ and $/k/$ often transliterated as j and k , respectively).

In MIA, nouns inside of a PP take an oblique form, sometimes called oblique case. The oblique forms of the wh_Q and the wh_{RC} in Hindi and Marwari,

	Interrogative (wh_Q)		Relative Pronoun (wh_{RC})	
Nominal	<i>kɔn</i>	‘who?’	$\widehat{d}zɔ$	‘who, which, that’
	<i>kja</i>	‘what?’		
Temporal	<i>kəb</i>	‘when?’	$\widehat{d}zəb$	‘when’
Locative	<i>kahã</i>	‘where?’	$\widehat{d}zahã$	‘where’
Manner	<i>kese</i>	‘how, in what way?’	$\widehat{d}zese$	‘how, in what way’
Kind	<i>kɛsa</i>	‘what kind?’	$\widehat{d}zɛsa$	‘what kind’
Degree	<i>kɪtna</i>	‘how much/many?’	$\widehat{d}zɪtna$	‘how much/many’
Reason	<i>kjũ</i>	‘why?’	—	—

Table 6.1: Hindi wh -elements: Interrogatives and Relative Pronouns

	Interrogative (wh_Q)		Relative Pronoun (wh_{RC})	
Nominal	<i>kun</i>	‘who?’	$\widehat{d}zəko/\widehat{d}ziko$	‘who, which, that’
	<i>kaji</i>	‘what?’		
Temporal	<i>kəd</i>	‘when?’	$\widehat{d}zəd$	‘when’
Locative	<i>kətʰe</i>	‘where?’	$\widehat{d}zətʰe$	‘where’
Manner	<i>kɪkar</i>	‘how, in what way?’	$\widehat{d}zjũ$	‘how, in what way’
Kind	<i>kɛɖo</i>	‘what kind?’	$\widehat{d}zɛɖo$	‘what kind’
Degree	<i>kɪt:a</i>	‘how much/many?’	$\widehat{d}zɪt:a$	‘how much/many’
Reason	<i>kjũ</i>	‘why?’	—	—

Table 6.2: Marwari wh -elements Interrogatives and Relative Pronouns

which is irregular and does not pattern with other oblique nouns, are also phonologically similar to one another, indicating that they may be morphologically related, as well (Tables 6.3.1 and 6.3.1). While the form of the wh itself changes, relative pronouns still begin with $/\widehat{d}z/$ and interrogatives with $/k/$.

	Nominal wh_Q	Nominal wh_{RC}
Singular	<i>kɪs</i>	$\widehat{d}zɪs$
Plural	<i>kɪn</i>	$\widehat{d}zɪn$

Table 6.3: Hindi wh -elements: Oblique Nominal

	Nominal wh_Q , Oblique	Nominal wh_{RC} , Oblique
Singular	<i>kɪn</i>	$\widehat{d}zɪn$
Plural	<i>kɪŋ</i>	$\widehat{d}zɪŋ$

Table 6.4: Marwari wh -elements: Oblique Nominal

While an apparent similarity between the wh_{RC} and the wh_Q is not sufficient evidence to conclude that they are related – or, more specifically, that both

are *wh*-elements – it is an indication that they are not entirely independent. In the rest of this section, I will show that they are also syntactically and semantically similar.

6.3.2 MIA languages are *wh*_{RC} in-situ

MIA languages are *wh*-in-situ languages, meaning that the *wh*-element in a question does not overtly front for question interpretation but remains in its base position unless it is fronted for reasons other than interpretation. The *wh*-in-situ nature of these languages extends to correlative *wh*_{RCS}, as well, which may also remain in their base-generated position. Both nominal and adverbial *wh*_{QS} (as in 18a and 18b, respectively) and *wh*_{RCS} (see 19a and 19b) may remain in-situ and do not have to raise for interpretation – at least, not overtly. In order to differentiate the interrogative from the relative pronoun, in examples (18) and (19) I have glossed a question word like *kijo* as ‘which_Q’ and a relative pronoun such as *d̄ʒesa* as ‘how.manner_{RC}’. I will only use this convention when it is necessary to distinguish a *wh*_Q from a *wh*_{RC}. In all unmarked cases, the *wh*-word is a relative pronoun.

- (18) a. *tʰu kijo hatʰi dekhijo*
 you.SG which_Q.M.SG elephant.M.SG see.PFV.M.SG
 ‘Which elephant did you see?’ [MARWARI]
- b. *ap sima se kab milna ifahēge*
 you.HON Sima with when_Q meet.INF wish.FUT.M.PL
 ‘When would you like to meet with Sima?’ (from Kachru 2006, p. 35)
 [HINDI]
- (19) a. [*tʰaro səman d̄ʒis t̄d̄ʒori maj*
 your.M.SG things which.SG.OBL lockbox.OBL.F.SG in
rəkʰijodo he] ba t̄d̄ʒori mari he
 kept.M.SG PRS.3.SG that lockbox.F.SG mine.F.SG be.PRS.3.SG
 ‘Which lockbox your things are kept in, that lockbox is mine.’
 [MARWARI]

- b. [*tum d̥ʒese pəɽ^haĩ kər rəhe ho*]
you how.manner_{RC} studying do PROG.2 PRS.2.SG
veše aĩ^h:e əŋk lana muʃkɪl hoga
that.manner good.PL score take.INF difficult be.FUT.M.SG

'The way you are studying, it will be difficult to get good marks/grades.'
 (from Kachru 2006, p. 224) [HINDI]

Nominal correlatives may remain in-situ across many MIA languages, as noted by several authors, either explicitly (Dayal 1996; Mahajan 2000; de Vries 2005 for MIA languages) or because examples of correlatives include in-situ *wh_{RC}*-phrases (Bagchi 1994; Kachru 2006; Liljegren 2008). (20), below, includes examples of in-situ nominal *wh_{RC}*-phrases in three MIA languages: Bangla, Marathi, and Palula.

- (20) a. [*baRi-te je mee-Ti kaj kOre*] *tar*
house.LOC which girl-CLA work do.PRS.3 anaph.GEN
bhiSon OSukh
terrible illness

'The girl who works at my house is terribly ill.'
Lit.: 'Which girl/woman works in my house, she is terribly ill.' (from Bagchi 1994, p. 23) [BANGLA]

- b. [*kal jyanī gāṇḍ mhaṭla*] *tyācē nāv kāy*
yesterday who song sang.M.SG his name what_Q

'What is the name of the man who sang a song yesterday?'
Lit.: 'Who sang yesterday, what is his name?' (from Masica 1993, p. 413, citing Berntsen and Nimbkar 1975, p. 147) [MARATHI]

- c. [*baába khayí xarčá dawóol-u hín-u*]
father.OBL which expenditure ask.for.PFV-MSG be.PRS-MSG
eesó xarčá ghín-i ...
DEM.DIST.MSG expenditure take-CV

'Taking the reimbursement, which his father has demanded...'
Lit.: 'Which reimbursement his father demanded, taking that reimbursement...' (from Liljegren 2008, p. 350) [PALULA]

While MIA languages are *wh*-in-situ, the *wh*-phrase in both questions and correlatives may be fronted for pragmatic reasons. An example of the fronting of a nominal *wh*_Q-phrase is shown in (21).

- (21) [_{wh_Q} *kis-ko*]_i *ram* t_i *lajega*
 who_Q.OBL-ACC Raam bring.FUT.M.SG

'Who will Raam bring?' (from Kidwai 2000) [HINDI]

This fronting of an argument or adverbial is usually said to mark topicality or focus (Jayaseelan 1989, 1996; Lasnik and Saito 1992; Müller and Sternefeld 1993; Kidwai 2000).³

The *wh*_{RC}-phrase is constrained by the same movement restrictions as the *wh*_Q-phrase. While the fronting of the *wh*-element is nearly always optional, in cases where the *wh*-phrase is within an embedded, finite clause, the *wh*-phrase must obligatorily be fronted (Dayal 1996).

- (22) a. [_{CorrelIP} [_{RC} *d̄ʒis* *l̄ɽki* *se*]_i *r̄avi* *soʃʰta* *h̄e*
 which girl.F.SG with Ravi think.PFV.M.SG PRS.3.SG
ki *ram* t_i *m̄ila*] *ənu* *us-ko* *d̄ʒanti*
 COMP Raam met.PFV.M.SG Anu that-ACC know.IMPFV.F.SG
h̄e
 PRS.3.SG

'Ravi knows the girl who Ravi met with.'

Lit.: 'Which girl Ravi met with, Anu knows her.' (from Dayal 1996, p. 189)

[HINDI]

- b. * [_{CorrelIP} *r̄avi* *soʃʰta* *h̄e* *ki* *ram* [_{RC} *d̄ʒis*
 Ravi think.PFV.M.SG PRS.3.SG COMP Raam which
l̄ɽki *se*]_i *m̄ila*] *ənu* *us-ko* *d̄ʒanti*
 girl.F.SG with met.PFV.M.SG Anu that ACC
h̄e
 know.IMPFV.F.SG

Intended: 'Ravi knows the girl who Ravi met with.'

[HINDI]

3. For the sake of accuracy, I have attempted to leave the sentences just as they were elicited or, if found in natural speech, as my consultants said them. Many of the examples will be fronted, but this is likely a result of the context in which they were presented. Beyond assuming that fronting marks topicality or focus, I will not attempt to do any in depth analysis of the semantic contribution of fronting here.

This is further evidence that the relative pronoun wh_{RC} and the interrogative wh_Q are both true wh -elements with many of the same syntactic features. The fact that the wh_{RC} can remain in-situ raises the question of where the wh_{RC} -phrase is interpreted. While it is often assumed that the full wh_{RC} -phrase raises to Spec-CP at LF, in the next section I show that this leads to problems with the interpretation of the correlative clause.

6.3.3 Interpreting the wh_{RC} in-situ: Introducing Q_{COR}

In Section 6.3.2, I showed that the MIA wh_{RC} -phrase may remain in-situ and does not have to raise to Spec-CP at LF for interpretation. Rather than assuming that the wh -phrase raises covertly, I propose that it is interpreted in-situ and that there is a Q particle component, Q_{COR} , which raises from the wh_{RC} to Spec-CP. This not only allows the wh_{RC} -phrase to be interpreted in its base position but also allows the adverbial correlative to have an individual interpretation. This analysis of the wh_{RC} -phrase is inspired by Cable (2010)'s and Kotek (2014)'s approaches to interrogative wh -phrases.

Cable (2010) and Kotek (2014) assume that an interrogative wh -phrase, QP, includes a Q(uestion) particle. This Q particle undergoes wh -movement and raises to Spec-CP. This movement is what gives an interrogative its question interpretation. I suggest that the correlative wh_{RC} -phrase also includes a Q particle, Q_{COR} , and it is Q_{COR} which allows the wh -phrase to remain in-situ. A wh_{RC} -phrase like $\widehat{d\bar{z}iki} \widehat{t\bar{f}ori}$ or $\widehat{d\bar{z}o} \widehat{l\bar{a}rki}$ ‘which girl’ in Marwari and Hindi contains three components: the wh -word $\widehat{d\bar{z}iko}$ or $\widehat{d\bar{z}o}$ ‘which’, an NP, and Q_{COR} . These elements have the structure (23).



It is Q_{COR} which will give the correlative clause the correct interpretation. In the rest of this section, I give a brief summary of Cable and Kotek's approach to questions and outline an analysis of the correlative involving Q_{COR} .

Cable (2010) proposes that an interrogative phrase is a QP which is headed by a Q(uestion) particle (called Q following Hagstrom 1998, Kishimoto 2005). Cable bases his analysis in part on the syntax of Tlingit, which has an overt

Q-particle which is fronted along with the rest of the *wh*-phrase. An example of a Tlingit question is shown in (24).

- (24) *wáa sá sh tudinookw i éesh*
 how? Q he.feels your father

'How is your father feeling?' (from Dauenhauer and Dauenhauer 2000, p. 186, cited by Cable 2010, p. 3)

[TLINGIT]

Like other Tlingit questions, the *wh*-word *wáa* 'how' is accompanied by an overt Q particle *sá*.

Cable proposes the structure in (25) for interrogatives in both overtly *wh*-fronting languages and for many *wh*-in-situ languages. The complementizer C triggers the fronting of Q, causing the entire QP to raise from its base position within the clause to Spec-CP.

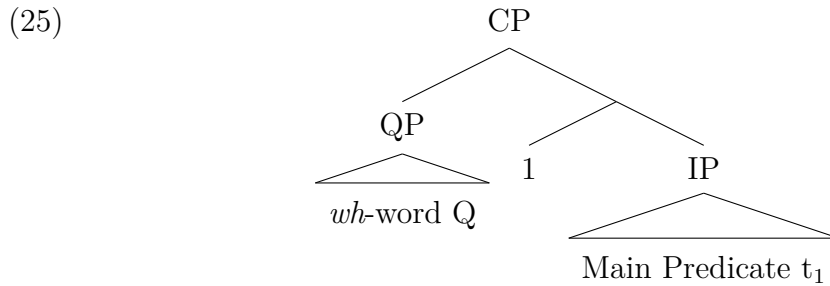

Where the entire QP will undergo overt movement in *wh*-fronting languages, in *wh*-in-situ languages this movement is covert.

In Cable's analysis, Q is base generated inside of the QP or *wh*-phrase, where it c-commands the *wh*-word. The structure of the *wh*-phrase *aadóo yagurí sá* 'whose boat Q', then, is (26). F indicates focus-marking.

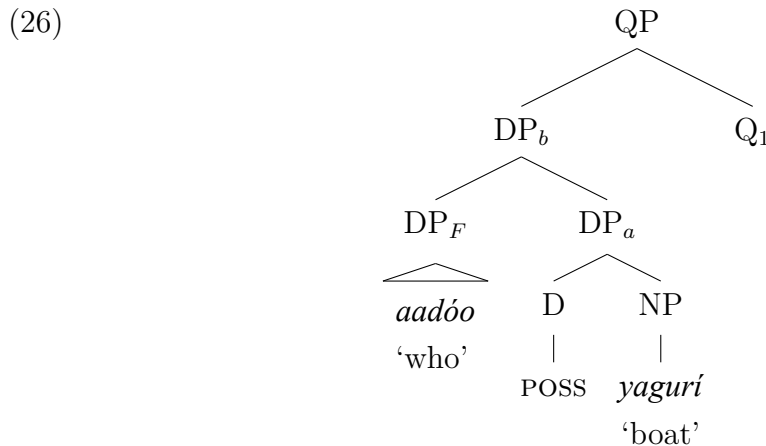

Q is a focus sensitive operator; where a *wh*-word is focussed, its semantic value is a set of focus alternatives, along the lines of Rooth (1985, 1992). The lexical entry for *what*, cross-linguistically, is (27) (Cable 2010).

- (27) focus semantics: $\llbracket \text{what} \rrbracket = \{x : x \notin \text{human}\}$
 normal semantics: $\llbracket \text{what} \rrbracket = \text{undefined}$

The meaning of Q_i relative to a variable assignment g is the value that g assigns to the index i , which is stipulated to be some element from the domain of choice functions. A choice function takes a set as an argument and returns a member of that set as its value. Q is then defined as (28), where Q takes as its argument the focus-semantic value of its sister.

- (28) $\llbracket Q \rrbracket^s = g(i) \in D_{cf}$

Cable's approach assumes that when Q raises to Spec-CP, the entire *wh*-phrase raises as well. This means that, under this approach, the wh_Q -phrase is not interpreted in-situ but still raises to Spec-CP at LF. In order to interpret the wh_{RC} -phrase in its base position, and in order to get the right interpretation of adverbial correlatives, Q_{COR} needs to be able to move out of the wh_{RC} -phrase. Kotek (2014) proposes an analysis of multi-*wh* questions which incorporates Cable (2010)'s focus sensitive Q particle, but with an important revision. Kotek suggests that Q may be base-generated within QP and, once QP has undergone interrogative movement to Spec-CP, may then raise out of QP to the spine of CP. I follow Kotek in assuming that Q may raise out of the *wh*-phrase, but I posit that in *wh*-in-situ languages such as Hindi and Marwari, Q may raise directly from the *wh*-phrase to Spec-CP.

In Kotek (2014)'s analysis, a simple question in a *wh*-fronting language like German or English has the structure in (29). Q is base-generated inside the *wh*-phrase, where it scopes over the *wh*-word. The type mismatch between Q and the *wh*-word triggers interrogative movement and the fronting of QP. Q then raises out of QP to Spec-CP in order for the phrase to get its question interpretation.

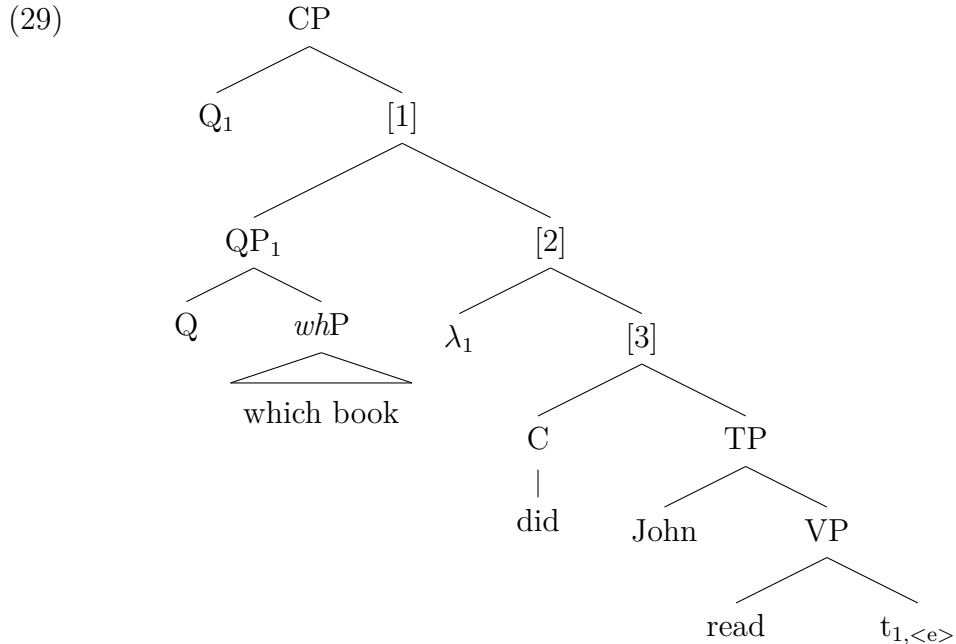

The construction of a question in a *wh*-fronting language, therefore, involves two steps of movement. First, the QP must raise to Spec-CP. Then, at some point in the derivation, Q itself must move out of QP to adjoin to the spine in the CP layer. Kotek stipulates that the movement of Q does not leave a trace or introduce a λ -binder.

I propose that there is a Q particle component of the correlative *wh*-element as well, which I call Q_{COR} .⁴ The structure of the *wh*_{RC}-phrase is (23).



Adapting Kotek's approach to *wh*-in-situ correlatives, I assume that QP (the *wh*_{RC}-phrase) does not need to raise covertly. Rather, the *wh*_{RC}-phrase may remain in its base position. Q_{COR} then raises out of the *wh*_{RC}-phrase to the spine of the clause – either to Spec-CP or adjoined to CP – to give the *wh*-clause the correct interpretation. Where the interrogative Q gives the question its denotation as a set of propositions, Q_{COR} gives the correlative its interpretation as an entity. The lexical entry I will assume for Q_{COR} is (31).⁵

4. Cable (2010) concludes that because Q is a focus sensitive operator, it can be found in other constructions besides questions. He suggests that there is a Q_{REL} operator in postnominal relative clauses and a Q_{FOC} involved in focus driven movement.

5. In applying Cable (2010) and Kotek (2014)'s analysis of QP, I will set aside the Focus-

$$(31) \quad \llbracket Q_{\text{COR}} \rrbracket = \lambda f_{\langle \text{et} \rangle} . \iota a_e (f(a) = 1)$$

Q_{COR} selects the unique individual which is described by the event contributed by the correlative clause. In fact, Q_{COR} has the same meaning as the definite article, *the*, but Q_{COR} undergoes movement where the definite article does not.

Applying this to the correlative, a nominal correlative in which the relative phrase acts as the object will therefore have the structure in (32).

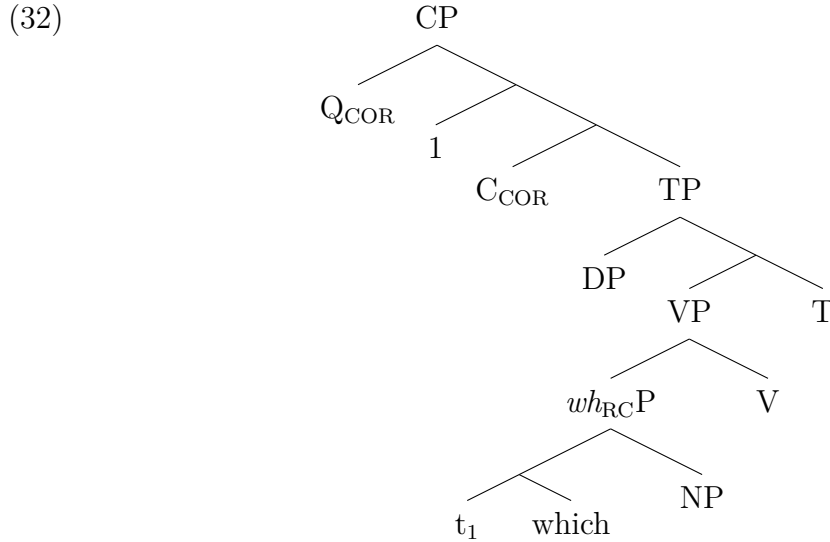

Q_{COR} raises from inside the wh_{RC} -phrase, leaving a trace and triggering a λ -binder. Applying the λ -binder, the argument of Q_{COR} will be a set of entities which are part of some event as defined by the correlative. If there is exactly one such individual, then CorrelCP will be defined. If not, then CorrelCP remains undefined.

For nominal correlatives, this approach is not much different than Cable (2010) or Kotek (2014)'s approach to questions. Whether the wh -phrase raises to LF or is interpreted in-situ, the correlative will have the same denotation. The advantage of this approach is the interpretation of adverbial correlatives, which have the structure in (33).

marked interpretation of the wh -phrase and look only at an ordinary semantic interpretation. This is not to say that the wh_{RC} -phrase does not include a focus marked element. In fact, I think it probably does, but focus does not seem to play a crucial role in the derivation of the meaning of the correlative.

(33)

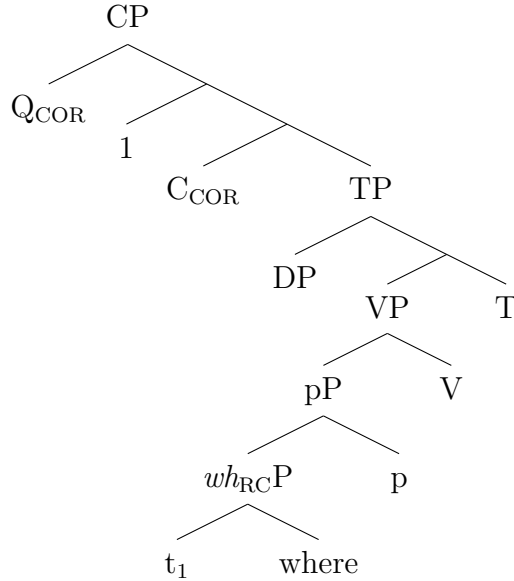

In the adverbial relative, the locative wh_{RC} -phrase enters the VP through a little-p projection, p_{event} (see Chapter 5). Just as in the nominal relative, Q_{COR} raises from the wh_{RC} -phrase, leaving a trace and triggering a λ -binder. While the wh_{RC} -phrase is adverbial, the trace of Q_{COR} is of type e . The adverbial relative will also have the semantic contribution of a definite description, contributing a unique individual who is a participant in the event described by the relative. For a detailed derivation of an adverbial relative, see Section 6.5.

As Chapter 4 shows, adverbial relatives are not adverbials but contribute an entity of type e . It is Q_{COR} which allows the adverbial relative phrase to enter the syntax as an adjunct while the relative itself is interpreted as a definite description. In Section 6.3.4, I briefly discuss the advantages of an analysis which assumes that Q_{COR} raises to Spec-CP independently over an analysis which assumes that the wh_{RC} -phrases raises to Spec-CP.

Section 6.4 and Section 6.5 walk through the derivation of a nominal and adverbial relative in detail.

6.3.4 The advantages of a Q_{COR} approach

There are, in general, two proposals for where a wh -phrase is interpreted. The first possibility is to assume that there is some mechanism which allows the wh -phrase to be interpreted in-situ. With respect to relatives, the in-situ approach has several advantages over the second approach, which assumes that

the *wh*-phrase raises to Spec-CP covertly in order for the clause (whether it is a question, correlative, or free relative) to get the correct interpretation.⁶

The proposal that the *wh*-phrase raises to Spec-CP at LF, also called the Movement Hypothesis (Dwivedi 1994), is based on a similar analysis for questions (Huang 1982; Hamblin 1973; Karttunen 1977). The Movement Hypothesis assumes that all languages have the same underlying LF, where some languages rely on overt movement of the *wh* and in others, such as Hindi and Marwari, the *wh*-phrase moves covertly.

A movement approach to in-situ *wh*-clauses assumes that the *wh*-phrase undergoes covert *wh*-movement from its base-generated position within the clause to Spec-CP. While this is the approach most often assumed for the interpretation of the correlative clause (Dayal 1996; Ivzorski 1996; Gajewski 2008), this type of approach leads to the wrong interpretation for adverbial correlatives. If an adverbial correlative denotes an individual, then fronting the adverbial *wh*_{RC}-phrase does not easily lead to the correct interpretation; there is a conflict between the types of the *wh*-phrase, the trace, and the λ -binder triggered by movement.

Consider the following example of an adverbial correlative construction in which the locative adverbial correlative *d̂ʒatʰe bʰiʀ reve* ‘where a crowd gathers’ relates to the locative correlate *bʰate* ‘there’.

- (34) [Correl_{CP} *d̂ʒatʰe bʰiʀ reve*] *t̂ʰoro*
 where_{RC} crowd.F stay.IMPFV.PRS.3.SG boy.M.SG
 bʰate d̂ʒave
 there go.IMPFV.PRS.M.SG
- ‘Where a crowd gathers, (the) boy always goes there.’ [MARWARI]

6. There is a third approach to analyzing free relative *wh*-clauses which I will not discuss in depth here. This is the *Base Generation Hypothesis*. The Base Generation Hypothesis, proposed by Bresnan and Grimshaw (1978), proposes that the *wh*_{RC} is base-generated at the CP as the head of the clause. It is then associated with a *pro* at the relevant position within the main clause. The *wh*-phrase has therefore, not undergone any movement, even in languages like English.

This type of analysis will not obviously work for a *wh*-in-situ languages like Hindi and Marwari. First, it would be difficult to account for the fact that the *wh*-phrase may remain in-situ if it were base-generated at a high position within the clause. Second, Marwari, Hindi, and other MIA languages do not allow adposition stranding. When a *wh*-phrase in MIA is fronted, the entire phrase undergoes pied piping so that any case marking or postpositions are fronted along with the *wh*-element. If the *wh*-phrase were base-generated at a high position, it would not be able to receive case marking.

Assuming that the wh_{RC} -phrase has raised to Spec-CP, the correlative $\widehat{d\bar{z}at}^e$ $b^hi\bar{r}$ $r\bar{e}v\bar{e}$ ‘where a crowd gather’ would have the structure (35). A little-p projection (Svenonius 2004, 2010) p_{event} allows the wh_{RC} -phrase $\widehat{d\bar{z}at}^e$ ‘where’ to enter the syntax as an adjunct.

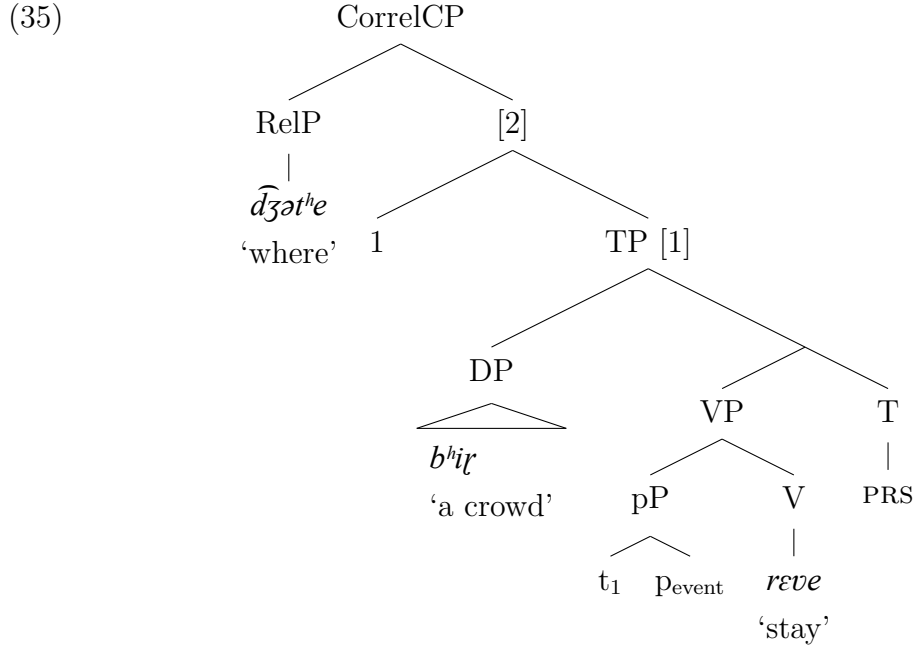

Our current semantic framework does not give us a definitive analysis of how traces and movement are related to semantic types, but we can safely assume that the λ -binder will bind a variable of whatever type the trace has. The trace can therefore either be of type e or type ℓ , where ℓ is a location. If the trace were of type e , though, the VP would be uninterpretable. Either the wh -phrase enters the syntax through a little-p projection of type $\langle \ell, st \rangle$ or adjoins to the verb phrase directly as a phrase of type $\langle st \rangle$. Either way, a projection of type $\langle e \rangle$ leads to a type clash and the construction is uninterpretable.

For this reasons, a common approach is to assume that the trace has the same semantic type necessary to combine with its sister. We could, therefore, assume that the trace left by the raising of $\widehat{d\bar{z}at}^e$ ‘where’ is of type ℓ where ℓ is in the domain D_ℓ .⁷ Working from the bottom up, the λ -binder than binds a variable of type ℓ .

The TP in 35 has a denotation of:

7. I am ignoring the vector phrase, for now, since assuming a vector phrase does not affect the current discussion.

(36) $\llbracket [1] \rrbracket = \lambda e_s . a \text{ crowd gather at } \ell \text{ in } e$

At the next node up the tree, the λ -binder applies, yielding the semantic contribution in (37).

(37) $\llbracket [2] \rrbracket = \llbracket [\lambda 1] \rrbracket (\llbracket \text{TP} \rrbracket) = \lambda \ell_{\langle \ell t \rangle} . \lambda e_{\langle s \rangle} . a \text{ crowd gathers at } \ell \text{ in } e$

How the denotation of the correlative gets from (37) to the correct interpretation of the correlative is not clear. The first difficulty lies in the semantic contribution of the wh_{RC} -phrase. The meaning of $\llbracket [2] \rrbracket$ is a function from locations to functions from situations to truth values, with a semantic type of $\langle \ell, st \rangle$. In order for the correlative to denote an individual, under this approach $\widehat{d\bar{z}at}^he$ ‘where’ must take a function of this type and yield the unique individual denoted by the correlative.

If we ignore the implausibility of a function which takes a function from locations to a function from situations to truth values and yields an individual, we can postulate that the locative $wh_{RC} \widehat{d\bar{z}at}^he$ ‘where’ would have the semantic type $\langle \langle \ell, st \rangle, se \rangle$ and would have as its lexical entry something like (38).

(38) $\llbracket where_{RC} \rrbracket$
 $= \lambda f_{\langle \ell, st \rangle} . \lambda e_{\langle s \rangle} . \iota z_{\langle e \rangle} (\exists \ell . f(\ell)(e) = 1 \text{ and } z \text{ is associated with } \ell)$

This leads to the second problem with this approach: the relationship between the location contributed by the locative wh_{RC} -phrase and the individual which the correlative contributes is not clear and must be stipulated as part of the meaning of the wh -phrase. Further, the individual z is part of the denotation of the correlative but which plays no real role in the event described by the CorrelCP. As Section 6.2 discusses, the correlative has the same meaning as a definite description. Typically, a definite description carries a presupposition that there is an individual as described by the content and that there is exactly one such individual. Under this approach, though, the unique individual contribute by the correlative is not an individual which is described by the content of the correlative but is an individual which is related (in some way) to a location which is describe by the content.

There are ways around this, of course. It is not impossible to write such a rule, but it is very stipulative to simply state that ‘ z is somehow associated with or related to ℓ ’. A more natural meaning might be ‘ z is at ℓ ’, but this would require the location of the event e to always occur at the location contributed by the correlative, which is not always the case. Because the meaning of the

correlative does not include a relation projection, the relation between the location and the individual must remain vague and undefined, as illustrated below.

There are some correlative constructions in which the relationship between the set of locations and the individual selected by the *wh*_{RC}-phrase is clear. In (39, repeated from Chapter 3), for instance, *d̂zahã ambər kam kərti hε* ‘where Amber works’ takes the set of locations where Amber works, which is ‘16 Matia Mahal Bazar, near Jama Masjid’.

- (39) [*d̂zahã ambər kam kərti hε*] *vo rεstɔrənt*
 where Amber work do.IMPV.M.SG PRS.3.SG that restaurant.M.SG
atʃ^h:a hε
 good.M.SG be.PRS.3.SG

‘Where Amber works, that restaurant is very good.’

The location where Amber works is, in turn, the location of the restaurant *Karim’s*, where *Karim’s* is the individual referred to by the correlative. Thus, the relation between the location described by the clause and the individual referred to by CorrelCP is clear. Ignoring the other issues with this analysis, this seems to derive the right semantic contribution for the correlative.

The proposed relation between the individual referred to by the correlative and the location of the event is usually less clear than what we see in (39). Consider again the sentence in (40, also repeated from Chapter 3).

- (40) [*dʒəde ap:a spiti re kəne dεro lagaijo*] *mē*
 when we.INCL Spiti near camp.PFV.M.SG I
 [*ut^he / un dʒəge mē*] *maro bətuʔa*
 there / that.OBL placeOBL.M.SG in my.M.SG wallet.M.SG
gəmo dijo
 lose give.LGT.PFV.M.SG

‘When we camped near Spiti, I lost my wallet {there/at that place}.’

In (40), the correlative *dʒəde ap:a spiti re kəne dεro lagaijo* ‘when we camped near Spiti’ is interpreted as meaning something like ‘the occasion of our going camping near Spiti’. Under the movement approach, though, the correlative must denote an entity which is associated with the time spent camping near Spiti. The denotation of the correlative would have to be something like (41).

- (41) $\llbracket \textit{when we camped near Spiti} \rrbracket =$
 $\iota z(\lambda e.\exists t.\textit{we camped near Spiti at time t in e and z is associated with t})$

The individual or entity associated with the time we spent camping near Spiti would then be interpreted as something like ‘the days we spent camping in Spiti’ or ‘June 5-7’.

The correlative construction in (40) requires that the individual contributed by the temporal correlative be related to some entity which is the reference object of the locative demonstrative phrase. That is, *dʒəde ap:a spiti re kəne dəro lagaiyo* ‘when we camped near Spiti’ should be interpreted as something like ‘the occasion of our going camping near Spiti’. That there is not relation projection to define the relation between the individual z and the time t , and because z has no direct role in the event described by the correlative, we must rely on other pragmatic processes in order to get to the meaning of the correlative construction.

In conclusion, while many analyses of the correlative clause have assumed that the wh_{RC} -phrase raises covertly to Spec-CP in order for the clause to get its correlative interpretation, this approach does not yield the correct semantic interpretation for adverbial correlatives. Not only must we assume that a wh_{RC} -phrase takes a set of locations, time, manner, etc. and yields an individual, but there is not clear, natural way to define what the relationship between that individual and that set is.

Assuming that there is a Q_{COR} operator as part of the meaning of the wh -phrase avoids both of these issues and allows the meaning of the adverbial correlative clause to follow directly from its components. If Q_{COR} leaves a trace of type e , then we must assume that the locative wh_{RC} is a function from individuals to locations with the semantic type $\langle e, \ell \rangle$. That is, $\widehat{dʒət^he}$ ‘where’ will perform much the same function as the sort-phrase introduced in Chapter 5. The adverbial correlative, therefore, has the structure in (42), where Q_{COR} has raised out of the wh_{RC} -phrase ‘where’.

(42)

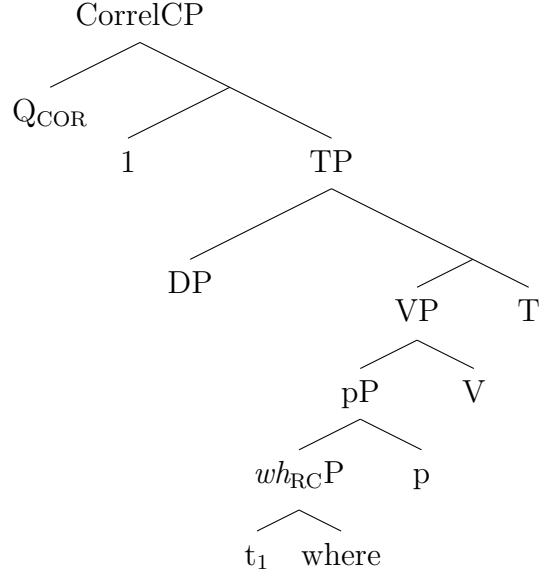

Q_{COR} operators over a set of individuals which participate in some event with the properties described by the correlative. The location of these events is the eigenspace of some individual of type e . The locative correlative *d̄zahā ambār kam k̄arti he* ‘where Amber works’ will then have the meaning (43).

- (43) [[where Amber works]]
 $= \iota a(\exists e.\exists \ell. \text{Amber works}(e) \wedge \text{location}(e, \ell) \wedge \ell \text{ is the eigenspace of } \iota y(y = a))$

The correlative *d̄zahā ambār kam k̄arti he* ‘where Amber works’ denotes the unique individual a such that there is an event of Amber working at some location ℓ where ℓ is the eigenspace of the unique individual y and $y = a$. That individual may then be identified as Karim’s, or as the location ‘16 Matia Mahal Bazar’.

In Section 6.5, I show exactly how this meaning is derived.

6.3.5 Conclusion

Correlative and interrogatives are not unique constructions but are made up largely of the same components. Both questions and correlative wh_{RC} -phrases include a wh -word, an NP, and Q particle Q_{COR} . The Hindi and Marwari *which*-phrases *d̄ṣiki t̄fori* or *d̄ṣo l̄rki* ‘which girl’ have the structure (44, repeated from above).

(44)

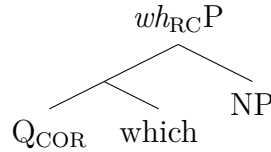

Q_{COR} is therefore base-generated within the wh_{RC} -phrase itself but then raises to Spec-CP, leaving behind a trace of type e and triggering a λ -binder. Q_{COR} itself, with the lexical entry below, acts as a definite article and is defined if and only if there is exactly one individual with the properties described by the correlative. In this way, the correlative clause itself acts much like the NP restrictor in a typical definite DP.

$$(45) \quad \llbracket Q_{COR} \rrbracket = \lambda f_{\langle et \rangle} . \iota a_e (f(a) = 1)$$

The meaning of the wh_{RC} -element *which* will have the lexical entry below.

$$(46) \quad \llbracket which \rrbracket = \lambda x . \lambda f_{\langle et \rangle} . \iota y (y = x \wedge f(y) = 1)$$

Adverbial wh_{RC} -phrases enter the syntax of the correlative as adverbial phrases but also include Q_{COR} as one of their components. A locative $wh_{RC}P$, for instance, will have the structure:

(47)

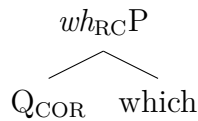

Where this approach is most effective is in the analysis of adverbial correlatives. For nominal correlatives, an approach which assumes that there is a Q_{COR} particle which raises out of the wh -phrase will be very similar to an analysis which assumes that the wh -phrase raises covertly to give the correlative clause the correct interpretation. The Movement Hypothesis leads to several difficulties with the analysis of adverbial correlative, though. Q_{COR} avoids these difficulties without any additional mechanisms or stipulations and allows the meaning of the adverbial correlative to follow naturally from its components.

In Section 6.4 and Section 6.5, I give a detailed account for how the semantic contribution of the correlative clause as a whole is derived.

6.4 Deriving the nominal correlative

In Section 6.3, I suggested that the wh_{RC} -phrase includes a Q particle just as wh_Q -phrases do. The Q particle in correlatives, Q_{COR} , is base-generated within the wh_{RC} and raises to CP at LF. In this section, I show how the semantic composition of the correlative clause is derived and demonstrate how Q_{COR} gives the correlative its definite interpretation.

Section 6.4.1 discusses the internal composition of the wh_{RC} -phrase itself, and Section 6.4.2 shows how the components of the wh_{RC} -phrase lead to the correct interpretation of the correlative. In Section 6.4.3, I outline some of the reasons I do not assume that the correlative CP is a DP.

6.4.1 The internal composition of the wh_{RC} -phrase

The nominal wh_{RC} -phrase includes three components: the wh -word, the Q particle Q_{COR} , and the sort phrase NP. It has the structure in (48).



Q_{COR} is a Q particle analogous to the Q particle found in questions (Cable 2010; Kotek 2014). The lexical entry for Q_{COR} , repeated from Section 6.3.3, is (31).

$$(43) \quad \llbracket Q_{COR} \rrbracket = \lambda f_{\langle et \rangle} . \iota a (f(a) = 1)$$

Q_{COR} , which acts like a definite article. $CorrelCP$ is defined if there is exactly one individual who is a member of the set defined by the correlative clause. If there are no individuals with the property of the correlative or if there are more than one, $CorrelCP$ is undefined.

Unlike other analyses of wh -elements (cf., Dayal 1996, Gajewski 2008), I do not assume that the wh_{RC} is vacuous or does not contribute anything to the interpretation of the clause. Instead, I propose that the wh -word $\widehat{d}3o$, $\widehat{d}3\partial ko$, or *which* has the lexical entry (49), below.

$$(49) \quad \llbracket \text{which} \rrbracket = \lambda x . \lambda f_{\langle et \rangle} . \iota y (y = x \wedge f(y) = 1)$$

- (52) $\llbracket 1 \rrbracket = \llbracket \text{which} \rrbracket(\llbracket t_1 \rrbracket) = \lambda f_{\langle et \rangle} . \iota y (y = g(1) \wedge f(y) = 1)$
 $\llbracket \text{large-woman} \rrbracket = \lambda x . x \text{ is a large woman}$
 $\llbracket wh_{RC}P \rrbracket = \llbracket \text{which large woman} \rrbracket = \iota y (y = g(1) \wedge y \text{ is a large woman})$

It is also possible for a *wh*-phrase to be plural, and for the correlative to have a plural denotation. An example of this is (53), in which the relative phrase $\widehat{d\zeta\eta} \text{ tab}\bar{e}r \text{ ne}$ ‘which children.DAT’ is plural.

- (53) $[\text{Correl}_{CP} [\text{wh}_{RC}P \widehat{d\zeta\eta} \quad \text{tab}\bar{e}r \quad \text{ne}] \text{m}\varepsilon \widehat{t\acute{a}k\text{let}}$
 $\text{which.PL.OBL children.MP.OBL DAT I candy.F}$
 $\text{di} \quad] \text{ve} \quad \text{b}\acute{a}c:e \quad \widehat{t\acute{h}u}p \text{ ha}$
 $\text{give.PFV.F those children.MP quiet be.PAST.3P}$

‘Which children I gave candy to, those children were quiet.’ [MARWARI]

In Karttunen’s system for *wh_Q*-phrases, both singular and plural *wh*-NP phrases are treated alike, so *which house* and *which houses* have the same denotation. Under the approach I have presented here, since the *wh*-element is not vacuous, a plural and a single *wh*-phrase will not have the same denotation. One way to account for this is to take a lattice-theoretic approach to plural individuals (Link 1983), in which a plural relative phrase denotes a unique, plural individual which is comprised of more than one child atom. To indicate that the plural correlative refers to a unique, plural individual, I use the sigma notation σ rather than the iota notation ι . (See Lahiri 2002, p. 7-8 for a discussion of how plurality can be incorporated into the denotation of the *wh_Q*-phrase.) The relative phrase $\widehat{d\zeta\eta} \text{ tab}\bar{e}r \text{ ne}$ ‘to t_1 which children’ would then have the denotation in (54).

- (54) $\llbracket \text{to } t_1 \text{ which children} \rrbracket = \sigma y (y = g(1) \wedge y \text{ is children})$

This approach is basically a combination of two different approaches. Like the Movement Hypothesis, the Q_{COR} approach assumes that there is some element which raises to Spec-CP in order for the clause to get its correlative interpretation. But, rather than assuming that it is the entire *wh_{RC}*-phrase which raises, the analysis I have presented here assumes that the *wh*-phrase is interpreted in situ and remains in its base position.

6.4.2 Derivation of the nominal correlative

A nominal wh_{RC} -phrase like $\widehat{d\acute{z}iki\ mo\acute{t}i}$ ‘which large woman’ has the semantic denotation in (55), as shown in Section 6.4.2.

(55) $\llbracket wh_{RC}P \rrbracket = \llbracket t_1 \text{ which large-woman} \rrbracket = \iota y(y = g(1) \wedge y \text{ is a large woman})$

In this section, I show how the correlative clause itself is derived and, more importantly, that it is Q_{COR} which gives the correlative its interpretation.

Consider again the correlative clause in (50), repeated below.

(47) [$\widehat{d\acute{z}iki}$ $mo\acute{t}i$ $m\acute{a}-ne$ $g\acute{a}\eta i$ $t\acute{a}\eta$ $kare$]
 which large.woman.F.SG 1S.OBL- ACC a.lot.F.SG harassment.F.SG
 va $lugai\ mari$ $hasu$ he
 do.PRS.IMPV.3.SG that woman.F.SG 1S.POSS.F.SG mother.in.law.F.SG

‘Which large woman is harassing me, that forceful woman is my mother in law.’

The wh_{RC} -phrase $\widehat{d\acute{z}iki\ mo\acute{t}i}$ ‘which large woman’ has the internal structure in (56).

(56)

```

graph TD
    wh_RC_P[whRCP] --- Q_COR[QCOR]
    wh_RC_P --- NP[NP]
    Q_COR --- d_ziki[" $\widehat{d\acute{z}iki}$   
'which'"]
    NP --- mo_t_i[" $mo\acute{t}i$   
'large-woman'"]
  
```

Q_{COR} , as shown in Section 6.3, raises to Spec-CP leaving behind a trace of type e and triggering a λ -binder. The resulting correlative clause $\widehat{d\acute{z}iki\ mo\acute{t}i\ m\acute{a}ne\ g\acute{a}\eta i\ t\acute{a}\eta\ kare}$ ‘which large woman is harassing me’ has the syntactic structure in (57).

(57)

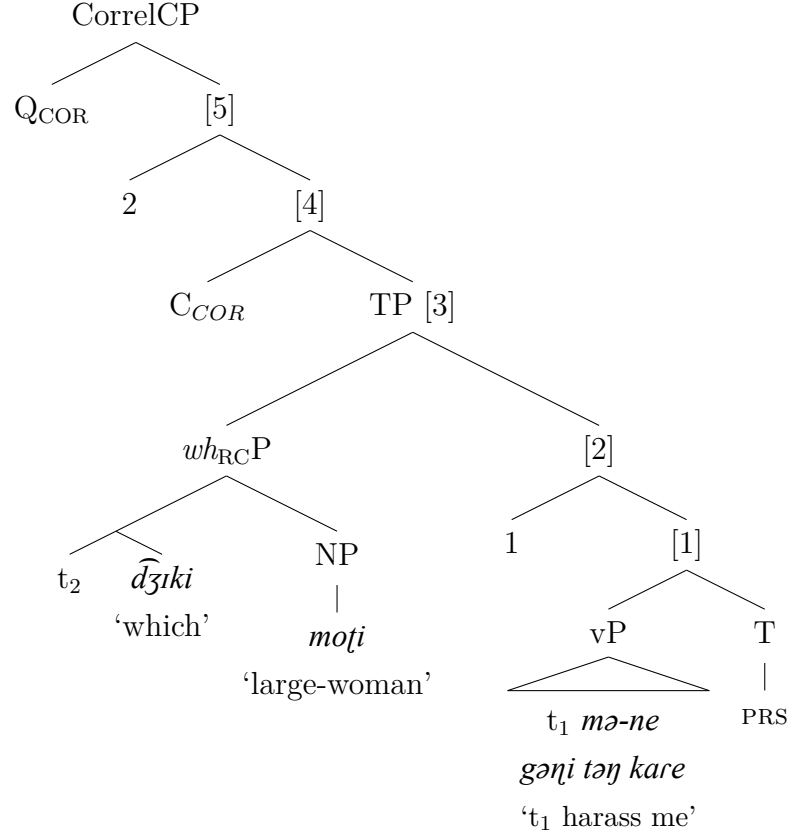

The derivation of the CorrelCP up to TP is straightforward. The voice head v introduces the agent, where the agent is the $wh_{RC}P$ $\widehat{d̄ʒiki\ moti}$ ‘which large woman’. $wh_{RC}P$ then raises to the subject position Spec-TP, leaving the trace t_1 .⁸ The λ -binder then applies to the node at [1].

- (58) $\llbracket [1] \rrbracket = \lambda e.is\ harassing(e) \wedge theme(e,speaker) \wedge agent(e,g(1))$
 $\llbracket [2] \rrbracket = \lambda y.\lambda e.is\ harassing(e) \wedge theme(e,speaker) \wedge agent(e,y)$

Once it has raised to the subject position, the wh_{RC} -phrase itself remains in-situ. Q_{COR} raises from the wh_{RC} -phrase to take scope over the entire correlative clause, leaving behind a second trace t_2 and triggering a second λ -binder. The derivation of TP is (59).

- (59) $\llbracket [3] \rrbracket = \llbracket [2] \rrbracket(\llbracket t_2\ which\ large-woman \rrbracket)$
 $= \lambda y.\lambda e.is\ harassing(e) \wedge theme(e,speaker) \wedge agent(e,y)(\iota y(y = g(2) \wedge y\ is\ a\ large\ woman))$

8. While the most natural English translation involves a copula, the literal translation of the Marwari VP $ḡəɳi\ t̄əɳ\ k̄are$ is ‘do a lot of harassing’, where $k̄ar-$ ‘do’ is a ditransitive. The combination of $k̄ar-$ ‘do’ and an NP is sometimes analyzed as a light verb construction because $St̄əɳ$ ‘harassment’ is contributing more to the interpretation of the VP than $k̄ar-$ ‘to do, to make’.

$$= \lambda e. \text{is harassing}(e) \wedge \text{theme}(e, \text{speaker}) \wedge \text{agent}(e, \iota y(y = g(2) \wedge y \text{ is a large woman}))$$

Analyses differ as to whether C in *wh*-clauses makes any semantic contribution. Dayal (1996) and Gajewski (2008) both assume that it does not. I, instead, assume that the complementizer C_{COR} , with the lexical entry (60), takes a set of events as defined by TP and says that there is such an event. Note that, in analyses which do not consider events, C will have no contribution to the semantics.

$$(60) \quad \llbracket C_{COR} \rrbracket = \lambda f_{\langle st \rangle}. \exists e. f(e) = 1$$

In (57), C_{COR} takes the set of events of the large woman $g(2)$ harassing the speaker and says that there is some event of the large woman $g(2)$ harassing the speaker.

$$(61) \quad \llbracket [4] \rrbracket = \llbracket C_{COR} \rrbracket(\llbracket [3] \rrbracket) \\ = \exists e. \text{is harassing}(e) \wedge \text{theme}(e, \text{speaker}) \wedge \text{agent}(e, \iota y(y = g(2) \wedge y \text{ is a large woman}))$$

The λ -binder then combines with the node at [3] through Predicate Abstraction, yielding the set of individuals x who are part of some event of in which x (who is a unique large woman) is harassing the speaker. In other words, node [5] may be interpreted as ‘the set of individuals who are large women harassing the speaker’.

$$(62) \quad \llbracket [5] \rrbracket \\ = \lambda a. \exists e. \text{is harassing}(e) \wedge \text{theme}(e, \text{speaker}) \wedge \text{agent}(e, \iota y(y = a \wedge y \text{ is a large woman}))$$

Q_{COR} , which is at Spec-CP, takes this set of individuals as an argument and refers to the unique individual who is a member of that set. The correlative clause *d̂ziki moti m̄ane ḡəŋi t̄əŋ kare* ‘which woman is harassing me’ has the semantic denotation in (63).

$$(63) \quad \llbracket \text{which large woman is harassing me} \rrbracket = \llbracket Q_{COR} \rrbracket(\llbracket [2] \rrbracket) \\ = \iota a(\exists e. e. \text{is harassing}(e) \wedge \text{theme}(e, \text{speaker}) \wedge \text{agent}(e, \iota y(y = a \wedge y \text{ is a large woman})))$$

To generalize, this means that the correlative clause denotes the unique individual who is a part of some event defined by the clause whose role in

that event is according to the position of the wh_{RC} -phrase. The raising of Q_{COR} does two things. First, Q_{COR} gives the correlative clause its definite interpretation. Secondly, because Q_{COR} raises from within the wh_{RC} -phrase, the relationship between Q_{COR} and its trace defined the role of the individual contributed by CorrelCP in the event defined by the clause.

As outlined in Chapters 3 and 5, because the correlative refers to a unique individual, the demonstrative correlate in the main clause may then take this unique individual as its argument. The correlative construction in (50) would have the constituent structure and denotation in (64) (using English words to represent the Marwari), where the correlative clause and its semantic contribution are underlined.

- (64) a. [$MC-CP$ [$DemP$ [$CorrelCP$ [RC which woman] is harassing me] that R woman] is my mother in law.]
- b. $\lambda e.be$ my mother in law(e) \wedge theme($e, \iota z(z = \iota a(\exists e'.is\ harassing(e') \wedge$
theme($e', speaker$) \wedge agent($e', \iota y(y = a \wedge y$ is a large woman)))) $\wedge z$
 is a woman \wedge DIST(z, w, a, t))

While the analysis which I have presented here was developed independently, it has some similarities to Gajewski (2008)'s analysis of the relative phrase in MHC constructions. Gajewski also proposes that definiteness, or at least maximality, enters the syntax at two different points in the derivation. He does this through a maximality projection MAX, triggered by the wh -element, and an iota operator (ι) which is similar to but distinct from the iota used to show definiteness.

There are some important differences, of course. Gajewski assumes that the entire wh_{RC} raises at LF, which is a problem for adverbial correlatives. Also, like Dayal (1996), Gajewski assumes that the wh -element $\widehat{d}3o$ 'which' only acts to trigger the MAX projection but does not make any semantic contribution, and most of the work of the relative phrase is done by covert operators, including a maximalizing MAX operator and the iota operator. (In my analysis, most of the work done by the MAX and iota operators will be done by the wh_{RC} $\widehat{d}3o$ 'which' and the Q_{COR} operator respectively). Most importantly, though, Gajewski (2008, p. 4)'s purpose is not to introduce a new semantic contribution for the correlative but to show the semantic contribution for the correlative suggested by Dayal (1996) can be derived more naturally, without stipulation. He follows Dayal (1996) in assuming that the MHC denotes a set

of relations determined by a unique function, where the main clause denotes a relation. Both the single headed and multi-headed correlative are assumed to adjoin to the IP of the main clause. Thus, while our analyses are similar in some ways, Gajewki's analysis fails to address the remaining questions regarding the correlative including the relationship between the correlative and the demonstrative and why, as Bhatt (2003) shows, the correlative can only be base-generated within the same constituent as the demonstrative (see Chapter 2, Section 2.2).

In Section 6.5, I turn to the derivation of the adverbial correlative. While the adverbial correlative has a semantic contribution much like that of the nominal correlative, the internal structure of the wh_{RC} -phrase will look somewhat different. Just as with nominal correlative, it is ultimately Q_{COR} which gives the adverbial correlative its definite interpretation.

6.4.3 Evidence that the correlative is not a DP

Many analyses of internally headed relative type structures such as correlatives and free relatives assume that the wh -clause is the sister of a covert D head (Jacobson 1995; Caponigro 2003; Gajewski 2008). There are several variations of this analysis available, but they all rely on a maximalizing or definite projection outside of the CP.

In the analysis that I present here, while I treat the correlative as a definite, I assume that the CorrelCP is a CP and is not embedded under a DP (cf., Groos and van Riemsdijk 1979; Jacobson 1995; Dayal 1996; Izvorski 2000). I propose that it is Q_{COR} which gives the correlative its definite reading and which, ultimately, makes the correlative clause a CorrelP rather than a CP. Rather than assuming that there is an independently generated D head within the syntax of the correlative, though, Q_{COR} is base-generated as part of the wh_{RC} -phrase and raises from its base position within the correlative clause to Spec-CP.

One piece of evidence showing that correlative clause is not a DP is that, in Hindi and other MIA languages, the correlative often cannot enter the syntax in a position where a DP is normally allowed (Dayal 1996).

There are a few cases where a correlative (or free relative) can enter the syntax directly. (65) shows two examples of this.⁹

9. Veneeta Dayal (p.c.) assumes that this is a case of a correlative being licensed by a

- (65) a. [$\widehat{d}zo$ *larki* *kʰəʃi* *he*] *ləmbi* *he*
 which girl.F.SG standing.F.SG be.PRS.3.SG tall.F.SG be.PRS.3.SG
 'Which girl is standing is tall.' (from Bhatt 1997, p. 56) [HINDI]
- b. [$\widehat{d}zo$ *larka* 'sports medal' $\widehat{d}zita$ *he*]
 which boy.M.SG sports medal win.IMPFV.M.SG PRS.3.SG
 'academic medal' $\widehat{d}zita$ *he*
 academic medal win.IMPFV.M.SG PRS.3.SG
 'The boy who wins the sports medal wins the academic medal.'
 (from Bhatt 1997, p. 60) [HINDI]

It is much more common, though, for the correlative to be blocked from entering the syntax in a case marked position, even where a DP would normally be allowed to appear. This is described by the Case Resistance Principle (Stowell 1981), introduced in Chapter 4. The Case Resistance Principle states that a finite clause is not allowed to appear in an argument position if it is case marked by a preposition. In (66), for instance, the correlative clause $\widehat{d}zako$ *pəʃla* *kətum* *kəriyo* 'which one finished first' cannot act as the subject of the clause because the subject must receive accusative case marking *ne*. The correlative can only enter the syntax through a demonstrative.

- (66) * *marsab* [_{KP} [_{SHC} $\widehat{d}zako$ *pəʃla* *kətum* *kəriyo*] *ne*]
 teacher which first finish do.PFV.M.SG ACC
ek *nenō* *inam* *dijo*
 one small.M.SG gift.M.SG give.PFV.M.SG

Intended: 'The teacher gave a small gift to which student finished first.'

[KM MAR.]

This restriction on the correlative entering the syntax in a case marked position is, in essence, the demonstrative requirement.

It has been argued that it is necessary to assume a DP outside of definite *wh*-clauses because some free relatives can have an indefinite interpretation (Hinterwimmer 2008; Caponigro et al. 2012). Having an optional D head allows for both a definite and indefinite reading, where appropriate. In these demonstrative, where the demonstrative then undergoes *pro*-drop. Under this approach, a correlative is never allowed to enter the syntax as an argument. Bhatt (1997) argues that, in these cases, the correlative clause is in fact a free relative which is allowed to enter the syntax as an argument when that argument is not case marked.

cases, because it is Q_{COR} which gives the clauses its definite interpretation, an indefinite *wh*-clause would simply include a Q particle which does not give the clause a definite interpretation.

Another reason to assume that the correlative is a DP and not a DP is that, cross-linguistically, no language has been documented which shows any evidence of a D-head external to the correlative or free relative clause (Caponigro et al. 2012).

6.5 Deriving the adverbial correlative

While the adverbial correlative construction is a true correlative construction, with the same syntactic features as the nominal correlative construction, the fact that the adverbial correlative is headed by an adverbial *wh*-phrase means that its internal structure will be inherently different. In this section, I will look at both the underlying structure of the adverbial correlative and how Q_{COR} allows the adverbial correlative to denote an individual rather than a location, time, manner, kind, or degree.

In Section 5.2, I outline the proposed analysis for the internal structure of the wh_{RC} -phrase. I show that an adverbial correlative includes three components: Q_{COR} , a *wh*-element WH , and a SORT-operator of the same type seen in the analysis of PPs and the adverbial demonstrative. It is the SORT-phrase which will give the wh_{RC} its adverbial interpretation. Like the nominal correlative, Q_{COR} will raise out of the wh_{RC} -phrase to Spec-CP in order to give the correlative its definite interpretation.

I go on to show how this analysis will yield the correct interpretation of the adverbial correlative (Section 6.5.2).

6.5.1 The adverbial wh_{RC} -phrase

Like the adverbial demonstrative, the adverbial relative clause also includes a SORT operator which allows us to define a location, time, manner, etc. in reference to a reference object.

Recall the internal structure of the locative PP introduced in Chapter 5. A Marwari or Hindi VP modified by a postpositional phrase (PP) would have the following structure (using English words to represent the structure in Hindi and Marwari). In brief, the PP denotes a set of vectors whose source (SRC) is

a location ℓ' , where ℓ' is a location defined as being near the eigenspace of the reference object, ‘the house’ (see Chapter 5).

(67) a. [VP [pP [VectorP [[DP the house] sort- ℓ] near] from] p_{event}] come]

b.

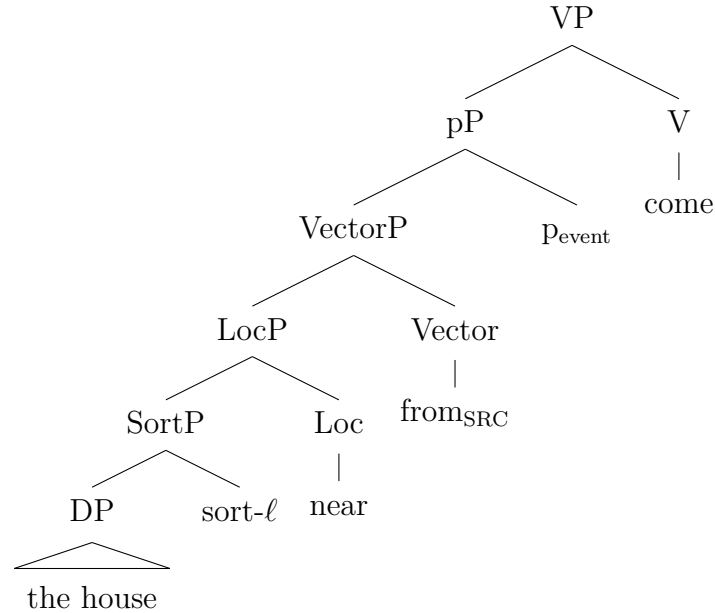

Building on Zwarts and Winter (2000), Svenonius (2004), and Svenonius (2010), I assume that the SORT head defines a region which is the space occupied by the reference object, in this case the eigenspace of the house. The PP itself denotes a set of vectors which originate at a region ℓ' , where ℓ is defined in reference to the location of the reference object, $\text{EIGEN}(x)$. Similarly, an adverbial demonstrative denotes a proximal or distal location which is defined in terms of a reference object, but the reference object in this case is the interpretation contributed by i and R .

The same components can be implemented in the analysis of the adverbial wh_{RC} -phrase. Like PPs and the adverbial demonstrative, the wh_{RC} -phrase includes a SORT operator. In a locative PP, for example, the $sort-\ell$ takes the reference object x as an argument and defined a location $\text{EIGEN}(x)$, which is the location of the reference object itself. In the case of an adverbial wh_{RC} -phrase such as Marwari $\widehat{d}\widehat{z}\widehat{a}t^he$ ‘where’, the SORT-operator $sort-\ell$ takes an individual which is in an identity relation with the trace as its argument. Ultimately, the correlative will then refer to an individual who is part of an event which occurs at some location defined in terms of that individual. For example, a correlative like $\widehat{d}\widehat{z}\widehat{a}h\widehat{a} \widehat{a}mb\widehat{a}r \widehat{k}am \widehat{k}\widehat{a}rti \widehat{h}e$ ‘where Amber works’ will have the interpretation (68).

(68) the unique individual x such that Amber works at a location ℓ where ℓ is the eigenspace of a reference object y , and $x=y$.

An adverbial wh_{RC} -phrase is made up of three components: Q_{COR} , a SORT operator such as $sort-\ell$, and a WH-element which I will call WH_{adv} . The internal structure of a locative wh_{RC} -phrase such as $\widehat{d\bar{z}\bar{a}t^h e}$, $\widehat{d\bar{z}ah\bar{a}}$, or *where* is (69).



The sort-phrase $sort-\ell$ is acting as a restrictor much as the NP in a demonstrative phrase.

Like the nominal wh_{RC} -phrase, I do not assume that the *wh*-word is vacuous or makes no semantic contribution. The sort operators, including $sort-\ell$, have the same lexical entry as they do in adverbial demonstratives and PPs (see Chapter 5). The lexical entries for WH_{adv} and $sort-\ell$ are in (70).

$$\begin{aligned}
 (70) \quad \llbracket wh_{adv} \rrbracket &= \lambda x. \iota y (y = x) \\
 \llbracket sort-\ell \rrbracket &= \lambda x. \lambda \ell. EIGEN(x, \ell)
 \end{aligned}$$

The Q_{COR} component of adverbial correlatives is the same Q_{COR} we saw in nominal wh_{RC} -phrases. The lexical entry of Q_{COR} is repeated below.

$$(43) \quad \llbracket Q_{COR} \rrbracket = \lambda f_{\langle et \rangle}. \iota a (f(a) = 1)$$

As with the nominal correlative, Q_{COR} raises out of the wh_{RC} -phrase to Spec-CP, leaving a trace and triggering a λ -binder. $sort-\ell$ then takes the individual contributed by the constituent $[t_1 WH_{adv}]$ and yields a location ℓ which is the eigenspace of that individual. A locative *wh*-phrase, then, is derived as shown in (71).

$$\begin{aligned}
 (71) \quad \llbracket [t_1 WH_{adv}] \rrbracket &= \iota y (y = g(1)) \\
 \llbracket loc-wh_{RC} \rrbracket &= \lambda \ell. EIGEN(\iota y (y = g(1)), \ell)
 \end{aligned}$$

Assuming that adverbial wh_{RC} -phrases include a SORT-operator component allows us to use the same components for all of the adverbial wh_{RC} -phrases. They each include a WH projection, Q_{COR} , and a SORT projection.

In this approach, the *wh*-element of adverbial correlatives (WH_{adv}) is the same for all of them. This means that the derivation of each adverbial correlative varies only according to which SORT-operator it is headed by. The WH-element of the adverbial wh_{RC} is slightly different from the semantic contribution of the nominal wh_{RC} -phrase *which* in that, where a nominal *wh*-phrase takes two arguments, NP and Q_{COR} , the wh_{adv} (typically) does not. The exceptions to this, the degree wh_{RC} and kind wh_{RC} , will be discussed in the next section.

It is also possible, of course, to define each adverbial correlative separately so that the relative phrase includes only the *wh*-element and a Q particle. The location wh_{RC} would then have the following denotation.

- (72) An alternative, non-decomposed definition for the locative wh_{RC}

$$\llbracket \text{where (alternative)} \rrbracket = \lambda x. \lambda \ell'. \exists \ell. \text{EIGEN}(\iota y (y = x), \ell) \wedge (\ell, \ell')$$

Ultimately, the two analyses yield the same denotation but they have slightly different underlying assumptions.

6.5.2 Derivation of the adverbial correlative

While the adverbial wh_{RC} -phrase enters the syntax of CorrelCP as an adjunct, both adverbial and nominal correlatives denote a unique, presupposed individual who is restricted to the property defined by the content of the correlative clause. In the previous section, I have assumed that the adverbial wh_{RC} also includes three components: Q_{COR} , a *wh*-element, and a SORT-operator.

In this section, I show that the adverbial wh_{RC} -phrase enters the syntax of CorrelCP in the same way as other adverbial phrases do. Q_{COR} then raises from the adverbial wh_{RC} -phrase to Spec-CP, leaving behind a trace of type *e* and giving the adverbial correlative clause the correct interpretation.

In order to show how the adverbial correlative is derived, consider the adverbial correlative construction in (73). In this example, the locative wh_{RC} is part of a locative PP modifying the event of Ishwar running.

- (73) $[\text{CorrelCP } i\text{sv}\acute{a}r \quad \widehat{d}\acute{z}\acute{a}t^h e \quad t^h a\text{ji } n\acute{a}v\acute{e} \quad] \quad d\acute{u}d\acute{z}o$
 Ishwar where.OBL until run.IMPFV.PRS.3 second.M.SG
mīnāk ut^he ã haru kare
 man.M.SG there from start do.IMPFV.PRS.3

'Where Ishwar runs to, the second man starts from there.' [MARWARI]

Like other PPs, I assume that the adverbial PP enters the syntax through a P_{event} projection which relates the set of vectors denoted by the PP to the event in the VP. The adverbial pP $\widehat{d\bar{z}\partial}t^haji$ ‘to/until where’ in (73) has the structure (74).

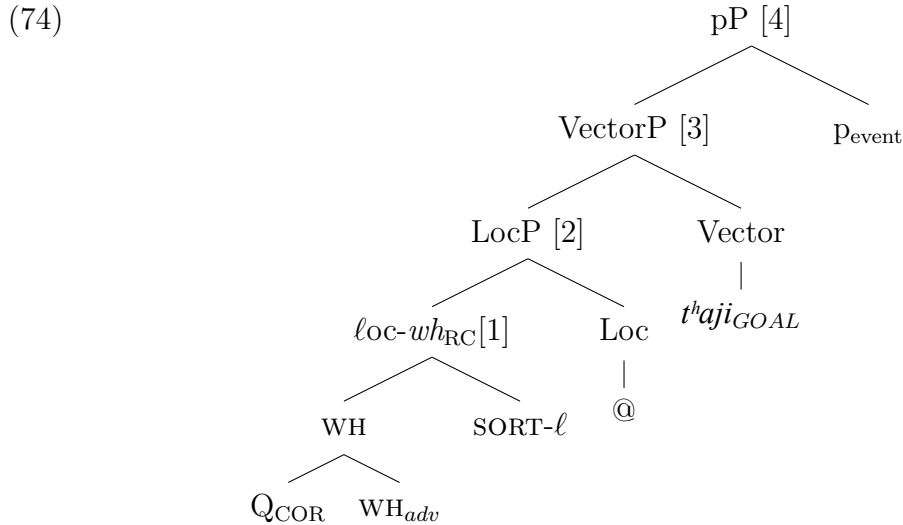

As the tree in (74) shows, the SORT-operator $SORT-l$ takes the [Q_{COR} WH_{adv}] constituent as an argument rather than the reference object as in non-*wh* PPs.

The semantic contribution of the locative wh_{RC} , as shown in Section 6.5.1, is repeated in (75), below. Because Q_{COR} has raised, leaving a trace, $loc-wh_{RC}$ denotes the location ℓ , where ℓ is the eigenspace of the unique individual that the assignment function g assigns to the index 1.

$$(75) \quad \llbracket [1] \rrbracket = \llbracket \text{where} \rrbracket = \lambda \ell. \text{EIGEN}(\iota y (y = g(1)), \ell)$$

In this example, there is no overt Loc projection. Here, rather than assuming that the Vector projection takes the SortP directly, I assume that the Loc projection is the covert P $@$ ‘at’ where $@$ defines a location ℓ which is equivalent to or ‘at’ $\text{EIGEN}(x)$.¹⁰ The semantic denotation of LocP is (76).

10. An alternative analysis would be to assume that the Vector head takes the SortP directly as an argument. One piece of evidence that there is a covert $@$, and therefore a LocP, is that *at* may be stranded in some English questions:

(i) Where did you get that at?

English alternatively allows the preposition to raise with the WH, but this does not apply to *at*.

(ii) * At where did you get that?

$$(76) \quad \llbracket [2] \rrbracket = \lambda \ell'. \exists \ell. \text{EIGEN}(\iota y(y = g(1)), \ell) \wedge @(\ell, \ell')$$

The vector phrase *t^haji* ‘to/until’ denotes a set of vectors with a direction toward and ending at a goal, where the goal is the location defined by the LocP *@ d^hʒat^he* ‘at where’. I assume that the vector *t^haji* ‘to/until’ is defined as (77).

$$(77) \quad \llbracket \text{until} \rrbracket = \lambda f. \lambda v. \exists \ell'. f(\ell') = 1 \wedge \text{until}(v, \ell')$$

The VectorP *d^hʒat^he t^haji* ‘up to where’ then has the denotation (78).

$$(78) \quad \llbracket [3] \rrbracket = \llbracket \text{up to where} \rrbracket \\ = \lambda v. \exists \ell'. \exists \ell. \text{EIGEN}(\iota y(y = g(1)), \ell) \wedge @(\ell, \ell') \wedge \text{until}(v, \ell')$$

Because the PP is modifying an event, it is introduced through a p_{event} head (79a), introduced in Chapter 5. The pP in (74) denotes the set of events in which there is a vector with a direction toward and ending at a goal, the location defined by *d^hʒat^he* ‘where’. Where p_{event} has the lexical entry (79a), the locative phrase then has the semantic contribution in (79b).

$$(79) \quad \text{a. } \llbracket p_{\text{event}} \rrbracket = \lambda f_{\langle vt \rangle}. \lambda e_s. \exists v. f(v) = 1 \wedge \text{LOC}(\text{ACTION})(e, V) \\ \text{b. } \llbracket [4] \rrbracket = \llbracket [p [\text{up to where}]] \rrbracket = \\ \lambda e. \exists v. \exists \ell'. \exists \ell. \text{location}(e, v) \wedge \text{EIGEN}(\iota y(y = g(1)), \ell) \wedge \text{at}(\ell, \ell') \wedge \text{SRC}(v, \ell')$$

The pP merges with the verb, and the rest of TP is constructed as normal. Q_{COR} has raised to Spec-CP, leaving a trace within the locative *wh_{RC}*-phrase t_1 . The voice head v introduces a subject at Spec-vP, which raises to Spec-CP, leaving the trace t_2 .

(80)

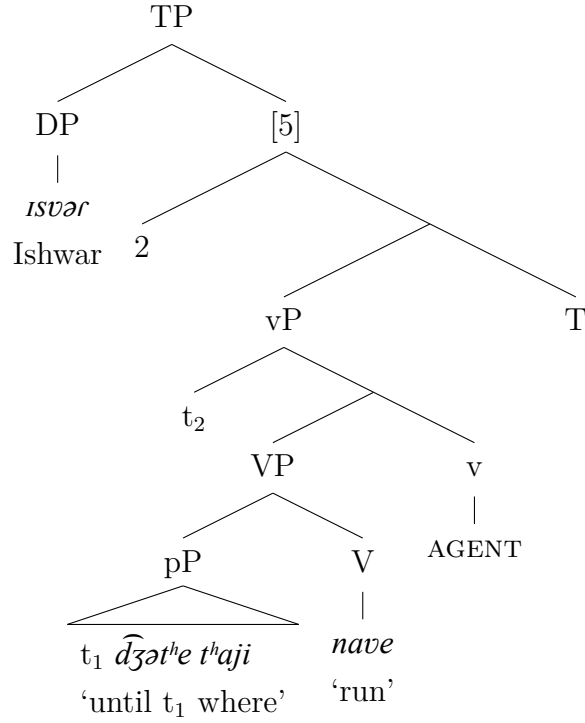

The derivation of TP is shown in (81).

$$\begin{aligned}
 (81) \quad & \llbracket \text{VP} \rrbracket = \llbracket \text{pP} \rrbracket (\llbracket \text{V} \rrbracket) \\
 & = \lambda e. \exists v. \exists \ell'. \exists \ell. \text{run}(e) \wedge \text{location}(e, v) \wedge \text{EIGEN}(\iota y(y = g(1)), \ell) \wedge \text{at}(\ell, \ell') \\
 & \quad \wedge \text{until}(v, \ell') \\
 & \llbracket \text{vP} \rrbracket \\
 & = \lambda e. \exists v. \exists \ell'. \exists \ell. \text{run}(e) \wedge \text{location}(e, v) \wedge \text{EIGEN}(\iota y(y = g(1)), \ell) \wedge \text{at}(\ell, \ell') \\
 & \quad \wedge \text{until}(v, \ell') \wedge \text{agent}(e, g(2)) \\
 & \llbracket [5] \rrbracket \\
 & = \lambda x. \lambda e. \exists v. \exists \ell'. \exists \ell. \text{run}(e) \wedge \text{location}(e, v) \wedge \text{EIGEN}(\iota y(y = g(1)), \ell) \wedge \text{at}(\ell, \ell') \\
 & \quad \wedge \text{until}(v, \ell') \wedge \text{agent}(e, x) \\
 & \llbracket \text{TP} \rrbracket = \llbracket \text{Ishvər } t_1 \widehat{d_3at'he} t'aji \text{ nave} \rrbracket \\
 & = \lambda e. \exists v. \exists \ell'. \exists \ell. \text{run}(e) \wedge \text{location}(e, v) \wedge \text{EIGEN}(\iota y(y = g(1)), \ell) \wedge \text{at}(\ell, \ell') \\
 & \quad \wedge \text{until}(v, \ell') \wedge \text{agent}(e, \text{Ishwar})
 \end{aligned}$$

Where Q_{COR} has raised to Spec-CP, the rest of the tree will have the same structure as the nominal correlative, as shown in (82). The C projection is occupied by C_{COR} .

(82)

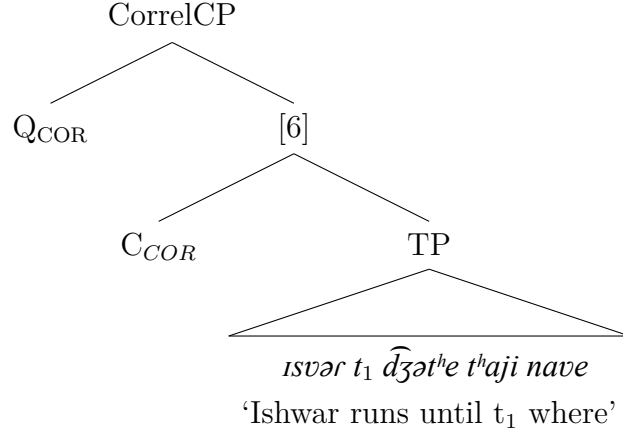

Like the nominal correlative, C_{COR} is not vacuous but contributes the meaning that there is some event as described by TP – in this case, an event of Ishwar running to the location defined by *where*.

- (83) a. $\llbracket C_{\text{COR}} \rrbracket = \lambda f_{\langle st \rangle} . \exists e. f(e) = 1$
 b. $\llbracket [6] \rrbracket$
 $= \exists e. \exists v. \exists \ell'. \exists \ell. \text{run}(e) \wedge \text{location}(e, v) \wedge \text{EIGEN}(\iota y(y = g(1)), \ell) \wedge \text{at}(\ell, \ell')$
 $\wedge \text{until}(v, \ell') \wedge \text{agent}(e, \text{Ishwar})$

Q_{COR} takes the node [6] as its argument. The semantic contribution of the correlative clause, then, is as in (84).

- (84) $\llbracket Q_{\text{COR}} \rrbracket(\llbracket [6] \rrbracket) = \llbracket \text{where Ishwar ran until} \rrbracket$
 $= \lambda f_{\langle et \rangle} . \iota a(f(a) = 1)(\exists e. \exists v. \exists \ell'. \exists \ell. \text{run}(e) \wedge \text{location}(e, v) \wedge \text{EIGEN}(\iota y(y = g(1)), \ell) \wedge \text{at}(\ell, \ell') \wedge \text{until}(v, \ell') \wedge \text{agent}(e, \text{Ishwar}))$
 $= \iota a(\exists e. \exists v. \exists \ell'. \exists \ell. \text{run}(e) \wedge \text{location}(e, v) \wedge \text{EIGEN}(\iota y(y = g(1)), \ell) \wedge \text{at}(\ell, \ell')$
 $\wedge \text{until}(v, \ell') \wedge \text{agent}(e, \text{Ishwar}))$

The correlative *isvar d3at^he t^haji nave* ‘where Ishwar ran until’ therefore contributes the unique individual *a* where there is some event of Ishwar running until a location ℓ , where ℓ is defined in terms of the unique individual *y* such that $y = a$. In other words, *isvar d3at^he t^haji nave* ‘where Ishwar ran until’ is the unique individual *a* which the location of the event Ishwar running until ℓ is defined in terms of. (More precisely, the location is defined in terms of the eigenspace of an individual *y* where *y* is related to the individual *a* through an identity relation.)

This analysis not only gives the right interpretation for both adverbial and nominal correlatives, but because of the link between Q_{COR} and its trace, it is

clear what the relationship is between the individual contributed by the clause and its role in the event. Recall example (40), repeated below.

- (33) [*dzəde ap:a spiti re kəne dəro lagaijo*] *mē*
 when we.INCL Spiti near camp.PFV.M.SG I
{ut^he / un dzəge mē} *maro bətuʔa gəmo dijo*
 there / that place in my.M.SG wallet lose give.LGT.PFV.M.SG

‘When we camped near Spiti, I lost my wallet {there/at that place}.

[MARWARI]

Based on the discussion in Chapter 5, we know that the interpretation of the correlative clause in (40) is something like ‘the occasion of our going camping near Spiti’. Under the analysis which I have presented here, the contribution of the correlative can be defined more precisely as (85), where *t* is a time in the domain of D_t .

- (85) [[when we went camping near Spiti]]
 = $\iota a(\exists e.\exists t.\text{camping near Spiti}(e) \wedge \text{time}(e, \text{at } t) \wedge t \text{ is the EIGEN-}$
 $\text{TIME}(\iota y(y = a)))$

The correlative clause *dzəde ap:a spiti re kəne dəro lagaijo* ‘when we camped near Spiti’ denotes the unique individual *a* such that there is an event of our camping near Spiti and the time of that event is defined in reference to the unique individual *y* where $y=a$.

Importantly, the semantics is not concerned with what the actual reference object of the location is in the real world. Because Q_{COR} scopes over the event, the object itself is defined in terms of the event described by the clause and the individual’s role in that event. The correlative *isvar d̄zət^he t^haji nave* ‘where Ishwar ran up to’ may even be loosely interpreted as ‘the place which Ishwar ran up to,’ as long as that place is an individual of type *e* and not a location.

6.6 Conclusion

In Chapter 4, I argued that all correlative clauses, including both adverbial and nominal correlatives, denote an individual. This allows either type of correlative to enter the syntax as the index of a demonstrative, even if that demonstrative is itself an adverbial.

In this way, correlatives are very similar to free relatives in their interpretation, as free relatives have also been argued to have both a definite and a universal interpretation (Cooper 1983, Jacobson 1995; Caponigro 2003; Caponigro et al. 2012).

I will not attempt to give an analysis of the universal reading of the correlative here, but this is where Elbourne (2013)'s inclusion of a situation variable will allow us to have multiple situations where there is a unique individual in each situation. Thus, the correlative may retain its definite interpretation while still having a universal reading.

Chapter 7

The multi-headed correlative and its interpretation

7.1 The multi-headed correlative construction

The prototypical multi-headed correlative is a single clause which involves two or more relative pronouns (wh_{RC}), where each wh_{RC} is associated with a demonstrative in the main clause. An example of a multi-headed correlative in Hindi, and the sentence which most of this chapter will be concerned with, is (1, repeated from Chapter 2). In this example, the two wh_{RC} -phrases $\widehat{d}z\acute{is}$ $l\acute{a}rki$ ‘which girl.OBL’ and $\widehat{d}z\acute{is}$ $l\acute{a}rke$ ‘which boy.OBL’ are associated with (as indicated by subscripts) the subject demonstrative vo ‘that’ and the object $usse$ ‘that.OBL-ACC’, respectively.

- (1) [MHC [$\widehat{d}z\acute{is}$ $l\acute{a}rki$ ne]₁ [$\widehat{d}z\acute{is}$ $l\acute{a}rke_2$ ke sat^h]
 which girl.F.SG.OBL *ERG* *which boy.M.SG.OBL* *with*
 k^hela] vo_1 us_2-se $\widehat{d}z\acute{it}$ $gaji$
play.PFV.M.SG *that that.OBL-ACC* *win go.LGT.PFV.F.SG*

‘Each girl who played against a boy defeated that boy.’

Lit.: ‘Which girl₁ played which boy₂, (s)he₁ defeated her/him₂.’ (from

Dayal 1996, p. 197)

[HINDI]

A MHC may involve nominal wh_{RC} -phrase, as in (1), or it may include adverbial wh_{RC} s as in (2, repeated from Chapter 2), below.

- (2) *anufa* [MHC *d̂ʒətʰe* *ũ* *d̂ʒətʰe* *tʰaji gandʰi d̂ʒi*
 Anusha where.OBL SRC where.OBL until Gandhi HON
pa[a-pa]a *gija*] *utʰe* *ũ*
 on.foot.M.SG.HON-RDP go.PFV.M.SG.HON there.OBL SRC
utʰe *tʰaji pa[i-pa]i* *d̂ʒai*
 there.OBL until on.foot.F.SG-RDP go.FUT.F.SG

'Every journey that Gandhi walked, Anusha will also make that same journey by foot.'

Lit.: 'From where until where Gandhi travelled on foot, Anusha will travel on foot from there to there.' [MARWARI]

The multiple headed correlative (MHC) construction only appears in languages in which the single headed correlative (SHC) is also available. This correspondence is strong enough that de Vries (2005, p. 21) suggests that it is a universal that '[t]he correlative strategy allows for multiple relativization.' He admits, though, that 'the empirical basis for this universal is still meager,' and it does appear to be too strong a statement to assume that all languages with SHCs will allow MHCs. Early Modern English, for example, had SHCs, but there is no evidence that it also had MHCs (Rob Truswell, p.c.). Dutch, similarly, has SHCs but not MHCs. For other languages with correlatives, particularly outside of Indo-Aryan languages, there is not enough data to determine whether they have MHCs or not. I suggest that de Vries' universal should be restated as (3).

(3) *Multi-headed Correlative Universal:*

Only languages which have single headed correlatives have the possibility of having MHCs.

That is, whatever features are necessary for a language to have SHCs are also necessary for MHCs to occur.

In this chapter, I look at the relationship between the MHC and the demonstratives in the main clause (MC). In Chapters 3 and 5, I argued that the SHC is an indexical argument of its correlate. This analysis assumes that the SHC is base-generated as part of the demonstrative phrase itself. In this chapter, I explore the possibility that a similar analysis may apply to the MHC. It is the availability of the SHC – or more specifically, the grammatical features which allow for the SHC – which allows for the MHC construction. While

there will be many remaining questions about the structure of the MHC and its semantics, here I hope to begin to answer at least the question of what it means for the MHC to be an overtly pronounced index of the demonstrative.

7.2 Syntactic features of the MHC

If it is true that the MHC is a variation of the SHC construction, then they should share at least some of the same syntactic features. There may then be additional features which allow for the MHC in the languages being looked at here.

The features of the SHC construction discussed in Chapters 2 through 5 are summarized in (4).

- (4) Features of the single headed correlative:
- (a) An independent clause headed by a relative pronoun, where the clause itself denotes an individual of type e or $\langle se \rangle$. Both the relative phrase and the demonstrative phrase may include an overt, independently generated NP.
 - (b) Descriptively, are subject to the demonstrative requirement (Dayal 1996). More specifically, the SHC enters the syntax as an overtly pronounced index of the demonstrative. May therefore be pronounced, linearly, immediately preceding the demonstrative itself.
 - (c) MIA languages, including Hindi and Marwari, allow the SHC to be fronted away from the demonstrative. This movement is restricted by islands for overt movement.
 - (d) Semantically, SHCs are definite, interpreted both as unique (whether singular or plural) and presupposed.¹

MHCs also have several of their own features, listed in (5), which differ from the SHC and which should be accounted for under an analysis of MHCs. (Many of these features were first described by Dayal 1996, Ch. 6). All of these features will be discussed in more detail later in the chapter.

1. I assume, for now, that the generic or universal reading of SHCs comes from the definiteness feature. One possible analysis for this is to assume that the correlative denotes a plural individual made up of all the singular individuals for whom there is an event as described by the content of the correlative.

- (5) Features of the MHC:
- (a) Broadly, the number of relative pronouns in the correlative clause must equal the number of demonstratives or indexicals in the main clause. More specifically, the number of individuals described by the relative pronoun(s) in the multi-headed correlative must correspond to the number of referents selected by the indexicals in the main clause.
 - (b) MHCs have both a singular reading and a pair list reading, much like *wh*-questions. The pair list reading shows point-wise uniqueness and exhaustivity.
 - (c) In Hindi, the order of the demonstratives in the main clause must correspond to the order of the demonstratives in the main clause (Dayal 1996). While bare demonstratives of the same noun class (i.e., which are both either masculine or feminine) in Marwari seem to have the same restriction, this restriction does not seem to hold for all Marwari MHCs. This restriction is discussed further in Section 7.5.3.

Further, the languages we are looking at here allow multiple-*wh* questions. While there isn't sufficient data at this point to conclude that this is necessary for the MHC construction, I have shown in the previous chapter that the syntax and the semantics of the correlative closely corresponds to the syntax and semantics of the interrogative WH. It is likely that a language which has SHCs but which does not allow for multiple-*wh* questions will similarly not allow for MHC constructions.

Note that there are other features of the MHC which are also relevant but which cannot be explored in depth here. Many of these correspond to WH semantics and the features of multiple-*wh* questions, such as superiority and intervention effects. Further, like all Marwari, Hindi, and MIA constructions, scrambling or the fronting of various elements for topicality or focus also plays a part in the interpretation of the correlative construction. These considerations, important as they are, will have to be left aside from the current discussion.

7.2.1 The MHC and demonstrative requirement

One of the restrictions on the MHC construction is that each relative pronoun must relate to a demonstrative or other appropriate correlate in the main

clause. This usually means that the number of demonstratives in the MC is the same as the number of *wh*_{RC}-phrases in the MHC, as in (6).

- (6) [MHC *ḍ̃is ləʁke ne ḍ̃o kitab pəʁʰi*]
 which boy.OBL.M.SG ERG which book.F.SG read.PFV.F.SG
us-ne us pəʁ lekʰ likʰa
 that.OBL-ERG that.OBL on essay.M.SG write.PFV.3.M.SG
 'Every boy read a book and wrote an essay about it.'
Lit.: 'Which boy read which book, that wrote an essay on that.' (*from*
 Dayal 1996, p. 199) [HINDI]

A MHC construction is ungrammatical if there is only one, singular demonstrative in the main clause, such as in (7).

- (7) * [MHC *ḍ̃o ləʁki ḍ̃is ləʁke ke satʰ kʰelegi*]
 which girl.F.SG which boy.OBL.M.SG with play.FUT.F.SG
vo ḍ̃it ḍ̃aegi
 that win go.LGT.FUT.F.SG
Intended: 'Which girl will play with which boy, she will win.' [HINDI]

It is not necessary for each relative pronoun to relate to a separate demonstrative. In (8), for example, both relative pronouns and relate to the plural demonstrative. A construction of this type, where a MHC relates to a plural demonstrative, is available in Marwari, as well.

- (8) [MHC *ḍ̃o ləʁki ḍ̃is ləʁke se battʃit kəʁ*
 which girl.F.SG which.OBL boy.OBL.M.SG with conversation do
rəhi thi] [DemP *ve*] *ek satʰ snema gaje*
 PROG.F.SG PST.F.SG they together cinema go.PFV.3.PL
hē
 PRS.3.PL

- 'The boy and girl who were talking went to the cinema together.'
Lit.: 'Which girl was talking with which boy, they went to the cinema together.'
 (*from* McCawley 2004, p. 302) [HINDI]

The demonstrative requirement in MHCs, therefore, does not require that each relative pronoun have a corresponding DemP in the main clause, but

that each relative pronoun must relate to some demonstrative, even if more than one wh_{RC} -phrase relates to the same one.

In addition to the requirement that each wh_{RC} -phrase relate to a demonstrative in the main clause, Dayal (1996) points out that order of the wh_{RC} -phrases must correspond to the order of the demonstratives. That is, the first DemP in the main clause must relate to the first wh_{RC} -phrase, the second DemP relates to the second wh_{RC} -phrase, and so on. This means that (1) cannot be interpreted as ‘*which girl played against which boy, he defeated her.*’ This holds even when it leads to an unexpected interpretation. In (9), for example, the only available interpretation is one in which the doctor pays the patient.

- (9) [MHC $\widehat{d}ʒɪs$ $dakʃər$ ne $\widehat{d}ʒɪs$ $məɾiz$
 which.OBL doctor.OBL.M.SG ERG which.OBL patient.OBL.M.SG
 ko $dekʰa$] $us-ne$ $us-ko$ $pəsa$ $dija$
 ACC see.PFV.M.SG that.OBL-ERG that.OBL-ACC money.M give.M.SG

‘Every doctor who saw a patient paid that patient.’

Lit.: ‘Which doctor saw which patient, that paid that.’ [HINDI]

As the subscripts here indicate, it is not possible for (9) to be interpreted as the patient giving the doctor money regardless of the pragmatic infelicity.

Marwari seems to allow some exceptions to this restriction. Whether this is a real difference between Hindi and Marwari will be discussed further in Section 7.5.3.

MHCs, therefore, are subject to the demonstrative requirement just as SHCs are, but the restriction is slightly different. While each wh_{RC} -phrase must relate to some demonstrative in the main clause, it is possible for more than one wh_{RC} to relate to the same demonstrative. Further, in constructions which involve more than one demonstrative, Hindi requires that order of the wh_{RC} -phrases in the main clause be reflected in the order of the demonstratives in the main clause.

7.2.2 Interpretation of MHC constructions

The MHC is an unusual construction cross-linguistically, and its interpretation may not be obvious. Here, I briefly summarize the semantic contribution of the MHC and its interpretation.

Consider the correlative construction in (1), repeated below.

- (1) [$\widehat{d}\bar{z}is$ $l\bar{a}rki$ *ne* $\widehat{d}\bar{z}is$ $l\bar{a}rke$ *ke sat^h*
 which girl.OBL.F.SG *ERG* *which boy.OBL.M.SG* *with*
 k^hela] *vo* *us-se* $\widehat{d}\bar{z}it$ *gaji*
 play.PFV.M.SG *that.(F.SG_M)* *that.OBL-ACC* *win go.LGT.PFV.F.SG*

Lit.: 'Which girl₁ played which boy₂, (s)he₁ defeated her/him₂.' (from Dayal 1996, p. 197) [HINDI]

Like multiple *wh* questions, the MHC has two readings. The first reading is the single pair reading, in which the MHC denotes a pair of individuals and each of the demonstratives refers to one member of that pair. The single pair reading of (1) is something like (10).

- (10) *There is a girl who played a game against a boy, and that girl won against that boy.*

The second reading of the MHC construction is the pair list reading. This is similar to the pair-list reading of multiple *wh* questions. (11a), for example, can be answered with a list of boy-girl pairs as in (11b).

- (11) a. Q: Which girl played which boy?
 b. A: Mary played John.
 Susan played Fred.
 Gertrude played Franklin.

Importantly, (11a) presupposes that each of the girls played exactly one boy but does not require that every boy was played against by some girl.

In a similar example, the multiple *wh* question (12a) can be answered with a list of boy-book pairs (12b). None of the members of that list, though, can be a boy who read two books, nor can one boy appear twice in the list of pairs. The answers in (12c) and (12d) are infelicitous responses to (12a).

- (12) a. Q: Which boy read which book?
 b. A: Dave read *The Minimalist Program*.
 Tom read *A Syntax of Substance*.
 c. #A: Melisa read *The Minimalist Program* and *A Syntax of Substance*.
 d. #A: Melisa read *The Minimalist Program*.
 Melisa read *A Syntax of Substance*.

In the same way, (1) must mean that all of the girls played exactly one boy. This is what Gajewski (2008) calls the *exhaustivity requirement*. There cannot be any girl in the context who did not play some boy. Further, (1) presupposes that no girl played more than one boy; she cannot have played one match against two boys or two matches, one against each boy. Gajewski calls this the *uniqueness requirement*.

Neither the exhaustivity requirement nor the uniqueness requirement applies to the second member of the pair. It is possible for one boy to have been played against by more than one girl, as long as it was in separate matches, and the MHC does not presuppose that every boy played in a game.

The exhaustivity and uniqueness requirement are illustrated in 13, below, where * indicates which combinations of girl-boy pairs are disallowed.

(13)

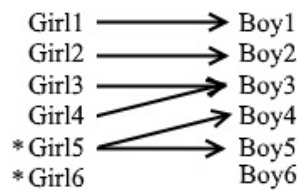

It is possible for both Girl3 and Girl4 to have played against Boy3, and it is felicitous for Boy6 not to have played anyone. (1) is not acceptable, though, in a situations where Girl5 played against Boy4 and Boy5, even if it was in separate games. This is a violation of the uniqueness requirement. It is also not felicitous for Girl6 to not have played anyone; this is a violation of the exhaustivity requirement.

The final requirement involves the interpretation of MHC along with the main clause. It must be the case that, for every girl-boy pair within the interpretation of the MHC, that girl defeated that boy. If there is any case in which the boy of the pair defeated the girl of the pair, the sentence is infelicitous. This, Gajewski calls *universal force*.

These aspects of the interpretation of the MHC as outlined by Dayal (1996) for Hindi held for Marwari, as well, in both nominal and adverbial MHCs. For more information on getting these judgments, see Chapter 8.

7.2.3 Introduction to an analysis of MHCs

There are two possibilities for how the MHC enters the syntax. Either it is a variation of the SHC construction, as Dayal (in Srivastav 1991 and Dayal 1996) concludes, or it is a distinct construction unrelated to the SHC as Bhatt (2003) argues. While Dayal assumes that SHCs and MHCs are variations of the same construction, she also assumes that they are both base-generated at IP – something which I have argued against here. If the analysis presented here is correct, and if they are both variations of the same construction, then the MHC must be an overt pronunciation of the index of the demonstrative as well.

In Section 7.2, I summarize the syntactic features of the MHC and present new data from Hindi and Marwari which shows that the MHC cannot be base-generated at IP but must enter the syntax adjacent to the higher demonstrative or below. Like the SHC, the MHC can be pronounced inside the main clause and is subject to island effects and the coordinate structure constraint. Preliminary data also shows that fronted MHCs may reconstruct to the higher demonstrative, as well, as illustrated through binding effects.

Section 7.4 presents an analysis of the MHC which assumes that, like the SHC, the MHC is the overt spell-out of the two demonstratives. I propose that, in a MHC correlative construction with two demonstrative correlates, the MHC denotes an ordered pair where each member of the pair is selected as the index of one of the demonstratives. The MHC, therefore, has all of the syntactic features along with a conjunction operator (*) which gives the MHC its ordered pair interpretation.

7.3 The MHC merges clause internally

The most obvious obstacle to a single analysis for both the SHC and the MHC is the fact that, in a prototypical example such as (14), it is impossible for the MHC to be pronounced at ‘the demonstrative’ because there is no single demonstrative which the MHC relates to.

- (14) [MHC *d̄ʒo ləʁki d̄ʒis ləʁke se*
 which girl.F.SG which.OBL boy.OBL.M.SG.OBL ACC
kʰela] *vo us-ko haraja*
 play.PFV.M.SG that that.OBL-ACC defeat.PFV.M.SG

'Every girl who played a boy defeated him.'

Lit.: 'Which girl played against which boy, she defeated him.' [HINDI]

Dayal (1996) and Bhatt (2003) conclude, for this and other reasons, that even if the SHC can or must be adjoined to the DemP, the MHC can only enter the syntax by merging at IP.

In this section, I present new data which shows that, just as the SHC is base-generated as part of the same constituent as the demonstrative, the MHC is also base-generated inside of the main clause and within the same constituent as, at least, the higher demonstrative. There are three pieces of evidence for this. First, it is possible for the MHC to be pronounced inside of the main clause, preceding the higher (or first) demonstrative (Section 7.3.1). Secondly, MHCs are subject to the same island effects as SHCs (Section 7.3.2). Finally, like SHCs, MHCs are also subject to the Coordinate Structure Constraint, indicating that they are part of the same constituent as the plural demonstrative correlate (Section 7.3.3).

7.3.1 The MHC can be pronounced inside the main clause

In most examples of MHCs, the correlative precedes the main clause, but it is possible for the MHC to be pronounced inside the main clause at the higher demonstrative. In the following examples, the MHC is found below the subject, structurally, and is pronounced immediately preceding the higher demonstrative. This is possible for both for nominal MHCs, as in (15a), and for adverbial MHCs such as (example 15b).

- (15) a. *rad̥ʒu* [_{MHC} *d̥ʒiko t̥ʰori d̥ʒiko kitab pəɾʰi*]
 Raju which girl.F.SG which book.F.SG read.PFV.F.SG
un t̥ʰori ne va kitab di
 that.F.SG girl.F.SG DAT that.F.SG book.F.SG give.PFV.F.SG
 'Raju gave each girl who read a book a copy of that book.'
Lit. 'Raju, which girl read which book, gave that girl that book.'
 [MARWARI]
- b. *pirvəɾ va|a h̥m̥d̥ʒra ne* [_{MHC} *d̥ʒəd be d̥ʒətʰe*
 family people hijra ACC when they there
ave] *təd unə-ne utʰe b̥ndava*
 come.IMPFV.M.PL then that.OBL-ACC there welcome.IMPFV.M.PL
 'A family welcomes a hijra when the hijra comes to their home.'²
Lit.: 'A family, when the hijra comes where, welcomes them there.'
 [MARWARI]

It is possible for a MHC, or a correlative with two relative pronouns, to be related to a single, plural demonstrative in the main clause. The MHC in these case may also be pronounced immediately preceding the demonstrative.

- (16) *pr̥nsipəl sa?* [_{MHC} *d̥ʒiko marsa? d̥ʒika t̥ʰora ne*
 principal.M.SG which teacher.M.SG which boy.OBL.M.SG ACC
pariksa m̥ nəkəl kəɾta ne pakəɾiyo] *va ne*
 exam in copy do.TA ACC catch.PFV.M.SG that.OBL.M.PL ACC
ofis m̥ bulaja
 office in call.PFV.M.PL
 'The principal called both the boy who cheated on the exam and the teacher who caught him into the principal's office.'
Lit. 'The principal called, which teacher caught which boy cheating, them into his office.'
 [MARWARI]

While it may be argued that this is simply a matter of scrambling, in which the subject has fronted to a position preceding the MHC, I show in

2. The people known as *hijras* are commonly referred to as eunuchs or transvestites in both scholarly and popular literature. I have chosen to use the term which is most commonly used across India, including by the hijra community itself. One of the ways which hijras make money is by blessing new-born babies in the family home. For more information, see Lal (1999), Nanda (1994), and Nanda (2003).

the next sections that there are cases in which the MHC not only can be pronounced at the higher demonstrative but must be pronounced there. I argue that this is evidence that the MHC is base-generated at, at least, the higher demonstrative, and that the fronting of the MHC is a case of movement. Further, the restrictions on the fronting of MHCs from within coordinated structure islands gives further evidence that the MHC is base-generated at the demonstrative phrase and shows that the MHC and a plural demonstrative, at least, are part of the same constituent.

7.3.2 MHCs and Island Effects

Not only is it possible for the MHC to be pronounced within the main clause, there are cases where the MHC must be pronounced adjacent to the demonstrative and cannot be fronted.

Just as Bhatt shows that the SHC correlative is subject to relative clause islands in Hindi (see Chapter 2, Section 2.3), we find the same island effects in MHC constructions in Marwari as well. Relative clause islands are islands for overt movement in both Hindi and Marwari. For example, as shown in (17), an argument base-generated within a relative clause island cannot be fronted or scrambled out of the island.

- (17) * *sita_i mə-ne* [DP *vo k^haŋi* [RC *ḍʒiki t_i lik^hijo*]]
 Sita I.OBL-DAT that story.F.SG which_{RC} write.PFV.M.SG
daj ave
 liking come.IMPFV.PRS.3.SG

Intended: 'Sita, I like the book which (she) wrote.' [MARWARI]

Similarly, a SHC at the left periphery cannot be associated with a demonstrative inside of a RC Island, as shown in (18, repeated from Chapter 2).

- (18) * [_{SHC} *d̥ʒo vəhã rəhta* *he*]_i *mud̥ʒ^he vo*
 which there live.IMPV.F.SG PRS.3.SG I-DAT that
kəhani [_{RC} *d̥ʒo arund^hati ne t_i us ke bare m̃*
 story.F.SG which_{RC} Arundhati ERG that.OBL about
lik^hi] *pəsənd he*
 write.PFV.F.SG liking be.PRS.3.SG

Intended: 'Who lives there, I like the story that Arundhati wrote about that boy.'
 [MARWARI]

The SHC in (18) must have undergone some type of movement out of the RC Island in order for the fronting of the correlative to be prohibited. If the correlative were base-generated at IP, then it should be able to bind into the RC Island.

In another example, an adverbial correlative at the left periphery cannot be interpreted as an adverbial demonstrative inside a RC Island. The SHC may only be associated with a demonstrative outside the RC Island but not a demonstrative inside of the island. Let's assume 'that girl' in this case is named Benu. (19) can only mean that Bhomlii told lies about Benu when Bhomlii was in school. (19) cannot mean that Benu laughed at Bhomlii while Bhomlii was in school. The unavailability of this second reading is unexpected if the correlative were able to bind the demonstrative inside the relative clause island.

- (19) # [_{CorrelIP} *d̥ʒəde va* *iskul m̃ t^hi*]_i *b^homlii*
 when that.F.SG school.OBL in be.PST.F.SG Bhomlii
va t̥^hori re bare m̃ [_{RC} *d̥ʒiki d̥ʒəŋo un mat^he*
 that.OBL girl.F.SG about who then that.OBL on
həsi] *d̥ʒ^hut boli*
 laugh.PFV.F.SG lie speak.PFV.F.SG

Intended: 'When she was in school, Bhomlii told lies about that girl who laughed at her then.'
 [MARWARI]

In the same way, a MHC cannot relate to a pair of demonstratives inside of a RC Island. In (20a), a MHC headed by two nominal relative pronouns is unacceptable if the two demonstrative correlates are inside a RC island.

grammatical.

- (21) *mə-ne va bat* [RC *d̥ʒəko bʰomli* [SHC *d̥ʒəko utʰe*
 I.OBL-DAT that.F.SG story.F.SG which_{RC} Bhomlii which there
reve] *un ne bare m̃ lkʰi*]
 live.IMPFV.3.SG that.OBL about write.PFV.F.SG
daj ave
 liking come.IMPFV.PRS.3.SG

'I like the story which Bhomlii wrote about, which boy lives there, that boy.'
 [MARWARI]

In a similar example, (22) is non-fronted version of (19), where the correlative-correlate constituent remains in its base-generated position inside of the relative clause.

- (22) *bʰomli va iʰori re bare m̃* [RC *d̥ʒiki* [SHC *d̥ʒəde*
 Bhomlii that.OBL girl.F.SG about which_{RC} when
va iskul m̃ tʰi] *d̥ʒəŋo un matʰe*
 that.F.SG school.OBL in be.PST.F.SG then that.OBL on
hasi] *d̥ʒʰut boli*
 laugh.PFV.F.SG lie speak.PFV.F.SG

'Bhomlii told lies about the girl who laughed at her at school.'

Lit.: 'Bhomlii told lies about the girl who, when she was in school, laughed at her.'
 [OSIAN MAR.]

In this case, (22) can only mean that the girl laughed at Bhomlii when Bhomlii was at school, with no reference to when Bhomlii told lies about her.

Multi-headed correlative constructions show the same pattern. While a fronted MHC is ungrammatical, when the MHC is inside of the RC Island, preceding the two demonstratives, are grammatical. (23a) is the non-fronted version of (20a), and (23b) is the non-fronted version of (20b).

- (23) a. *raʔul marsaʔ ne [RC d̥ʒo hoʃiʒo ke*
 Rahul teacher.OBL.M.SG ACC which_{RC} think.PFV.M.SG COMP
 [MHC d̥ʒaka iʃʰora ne d̥ʒiki iʃʰori
 which.OBL.M.SG boy.OBL.M.SG DAT which.F.SG girl.F.SG
daj ave] bo iʃʰoro ba ũ
 like come.IMPV.3.SG that.M.SG boy that.OBL.F.SG with
bijau kəre] milijo
 wedding.F.SG do.IMPV.3.SG meet.PFV.M.SG

'Rahul met a teacher who thinks that every boy who likes a girl should marry the girl that he likes.'

Lit.: 'Rahul met a teacher who thinks that, which boy likes which girl, that boy should marry that girl.' [MARWARI]

- b. *bʰomli iʃʰora ne [RC d̥ʒako [SHC d̥ʒatʰe bʰomli d̥ʒade*
 Bhomlii boy.OBL ACC who_{RC} where Bhomlii when
d̥ʒave] utʰe d̥ʒəŋe d̥ʒave] tokijo
 go.IMPV.3.SG there then go.IMPV.3.SG hit.PFV.M.SG

'Bhomlii hit the boy who follows her everywhere she goes.'

Lit.: 'Bhomlii hit the boy who, where Bhomlii goes when, goes there then.' [MARWARI]

Several examples of both SHCs and MHCs inside of the RC Island were tested with consultants from all three varieties of Marwari. All of them agreed that the embedded version, inside the RC island, is entirely grammatical and is 'good Marwari' while the fronted version 'does not mean anything.'

These examples show that, not only is it possible for the MHC to be pronounced at the higher demonstrative, there are cases in which the MHC cannot be pronounced at the left periphery and must be pronounced at the demonstrative. Where the demonstratives are inside of a RC island, the MHC is then blocked from fronting, indicating that the fronting of the MHC is a case of movement. This is an indication that the MHC cannot be adjoined to IP but must enter the syntax adjacent to, at the highest, the first demonstrative.

7.3.3 The Coordinate Structure Constraint and MHCs

In Chapter 2, I summarized Bhatt (2003)'s arguments that the SHC is subject to the Coordinate Structure Constraint and, therefore, the SHC and its demonstrative correlate are base-generated within the same constituent. In this section I show that, while the CSC is less rigid in Marwari, the MHC is subject to the same constraint. More specifically, Marwari does not allow a correlative base-generated at the second demonstrative in a coordinated structure from fronting. This restriction applies not only to SHCs but also to MHCs.

In Hindi, the Coordinate Structure Constraint (CSC, repeated below) means that where two correlative-correlate constituents are coordinated, movement of a correlative clause out of the coordinated structure is limited (Ross 1967).

(24) The Coordinate Structure Constraint

In a coordinated structure, no conjunct may be moved, nor may any element contained in a conjunct be moved out of that conjunct.

It is possible to coordinate two correlative-correlate pairs, as in (25a), but in Hindi both correlatives are prohibited from fronting out of the coordinate structure. (25b) shows that the fronting of the second correlative is ungrammatical. Movement of the first correlative clause away from the first demonstrative is, if not fully prohibited, significantly degraded (Bhatt 2003).

- (25) a. *rahul adʒkəl* [ConjP [SHC1 *dʒo kitab sɛra ne likʰi*]
 Rahul nowadays which book Sera ERG write.PFV.F.SG
vo ɔr [SHC2 *dʒo kartun ʃjam ne bənaja*] *vo*]
 that and which cartoon Shyam ERG make.PFV.M.SG that
paɾʰ rəha he
 read PROG.M.SG PRS.3.SG

'Nowadays, Rahul is reading the book Sera wrote and the comic book that Shyam made.'

Lit.: 'Rahul nowadays is reading, which book Sera wrote, that and, which comic (book) Shyam made, that.' [HINDI]

- b. * [SHC2 $\widehat{d}\bar{z}o$ *kartun fjam ne banaja*]_i *rahul*
 which cartoon Shyam ERG make.PFV.M.SG Rahul
a $\widehat{d}\bar{z}k\bar{a}l$ [ConjP [SHC1 $\widehat{d}\bar{z}o$ *kitab sera ne lik^hi*] *vo*
 nowadays which book Sera ERG write.PFV.F.SG that
ɔr t_i vo] *pa^hrəha he*
 and that read PROG PRS.3.SG

Intended: Which comic Shyam made, Rahul nowadays is reading which comic Shyam made, that, and that. [HINDI]

Not all Hindi varieties are subject to the CSC. As Bhatt (2003, p. 506, footnote 13) points out, some varieties of Hindi may not be subject to the CSC (Gambhir 1981; Dwivedi 1994), but ‘the putative CSC violations that have been reported for Hindi all involve extraction from the left conjunct’. Even in the varieties he considers, ‘[m]ost speakers find a clear contrast between the marginal [fronting of the first correlative] and the ungrammatical [fronting of the second correlative]’.

Marwari patterns with the varieties of Hindi which allow a correlative to be fronted away from the first demonstrative but still restrict the second correlative from being fronted. Like Hindi, Marwari allows coordination of correlative-correlate pairs, as in (26a). Marwari freely allows a correlative corresponding to the first demonstrative to front. Five consultants from three varieties of Marwari agreed that (26b) is acceptable without any apparent hesitation.

- (26) a. *ra^hul a $\widehat{d}\bar{z}k\bar{a}l$* [ConjP [SHC1 $\widehat{d}\bar{z}i^ki$ *kitab sera lik^hi*]
 Rahul nowadays which book Sera write.PFV.F.SG
bo *ɔr* [SHC2 $\widehat{d}\bar{z}i^ka$ *kartun sam banaja*] *bo*]
 that.M.SG and which comic Sham make.PFV.M.SG that
pə^de he
 read.IMPFV.3.SG PRS.3.SG

‘Rahul, nowadays, is reading which book Sera wrote, that, and which comic book Sham made, that.’ [MARWARI]

- b. [SHC1 *d̥ʒiki kitab sera likʰi*] *raʒul ad̥ʒkal*
 which book Sera write.PFV.F.SG Rahul nowadays
 [ConjP t_i *bo* *ər* [SHC2 *d̥ʒika kartun sam baŋaja*]
 that.M.SG and which comic Sham make.PFV.M.SG
bo] *pəʒe* *hɛ*
 that read.IMPFV.3.SG PRS.3.SG

'Which book Sera wrote, nowadays Rahul is reading that, and which comic book Sham made, that.'
 [MARWARI]

While Marwari allows the first correlative to front out of the coordinate structure, the fronting of a correlative away from a correlate in the second position of the coordinated structure is prohibited, so that (27) is ungrammatical.

- (27) * [SHC2 *d̥ʒika kartun sam baŋaja*] *raʒul ad̥ʒkal*
 which comic Sham make.PFV.M.SG Rahul nowadays
 [ConjP [SHC1 *d̥ʒiki kitab sera likʰi*] *bo* *ər* t_i *bo*]
 which book Sera write.PFV.F.SG that.M.SG and that
pəʒe *hɛ*
 read.IMPFV.3.SG PRS.3.SG

Intended: 'Which comic book Sham made, nowadays Rahul is reading, which book Sera wrote, that and that.'
 [MARWARI]

The CSC holds for adverbial correlatives as well. It is possible in Marwari to coordinate two adverbial correlative-demonstrative constituents, and it is acceptable for the correlative associated with the first demonstrative in a coordinated structure to be fronted. Not only is (28b) grammatical, but one consultant stated that (28b) is even better than (28a).³

3. Even though Indira Gandhi is Jawaharlal Nehru's daughter, they each kept different residences during their tenure as prime minister of India.

speaker. It is therefore impossible to conjoin a MHC and two demonstratives with another DP.

- (30) * *polis* [_{ConjP} [_{MHC} *d̂ʒika kedi d̂ʒike* *perija* *re hatʰe*
 police which guard which.OBL prisoner.OBL with
na gijo] *va lugai ər va*
 run.away go.LGT.PFV.3.M.SG that.OBL woman and that.OBL
minək] *nε pakaɾ lijo*
 man ACC catch take.LGT.PFV.M.SG

Intended: ‘The police caught, which guard ran away with which prisoner,
 that man and that woman.’ [OSIAN MAR.]

One way to test whether a MHC can move out of a coordinated structure is to look at the MHC-plural demonstrative construction. In (31), for example, the correlate of the MHC clause *d̂ʒiki t̂ʰori d̂ʒim t̂ʰora ũ ləristi hi* ‘which boy was fighting which girl’ is the plural demonstrative *un (doya) nε* ‘those two’ or ‘both of them’ in the main clause.

- (31) [_{MHC} *d̂ʒiki t̂ʰori d̂ʒim t̂ʰora ũ ləristi hi*]
 which girl which boy ACC fight.IMPV.F.SG PST.F.SG
hed-marsa? un (doya) nε ofis bulaja
 head-teacher those.OBL both ACC office call.PFV.M.SG

‘The principal called the girl and the boy who were fighting into his office.’
Lit.: ‘Which girl was fighting with which boy, the headmaster called
 them (both) into his office.’ [MARWARI]

The same MHC-demonstrative pair can be embedded within a coordinated structure along with another correlative-correlate constituent, as shown in (32a). Like the SHC examples above, if the MHC is at the first demonstrative, it may then be fronted away from the coordinated structure (32b).

- (32) a. *marsab* [_{ConjP} [_{MHC} *d̥ʒiko tʃʰoro d̥ʒiki tʃʰori ũ*
 teacher which boy which.OBL girl ACC
lədijo] *va* *donõ ne ər* [_{SHC} *d̥ʒiki tʃʰora*
 fight.PFV.M.SG those.OBL.M.PL both ACC and which boy
moʒa aya] *va ne*] *haka kərija*
 late come.PFV.M.SG that.OBL ACC scolding do.PFV.M.SG

'The teacher scolded the boy and girl who were fighting and the boy who arrived late.'

Lit.: 'The teacher scolded, which boy fought with which girl, them, and which boy arrived late, him.' [KM MAR.]

- b. [_{MHC} *d̥ʒiko tʃʰoro d̥ʒiki tʃʰori ũ* *lədijo*]_i *marsab*
 which boy which.OBL girl ACC fight.PFV.M.SG teacher
 [_{ConjP} *t_i va* *donõ ne ər* [_{SHC} *d̥ʒiki tʃʰora moʒa*
 those.OBL.M.PL both ACC and which boy late
aja] *va ne*] *haka kərija*
 come.PFV.M.SG that.OBL ACC scolding do.PFV.M.SG

'Which boy fought with which girl, the teacher scolded them and, which boy arrived late, him.' [KM MAR.]

A MHC associated with the second demonstrative, though, cannot be fronted out of the coordinate structure. This was true for all the examples where were tested, including (33).

- (33) * [_{MHC} *d̥ʒiko marsaʔ d̥ʒin tʃʰora ne pəriksa*
 which teacher which.OBL student.OBL.M.SG ACC exam.OBL
mẽ nəkal karta ne pakarijo]_i *heʔ-marsaʔ* [[*d̥ʒiki tʃʰori*
 in copy do.TA ACC catch.PFV.M.SG head-master which girl
paja tʃʰor li] *va ne ər t_i*
 money theft take.PFV.F.SG that.OBL.M.SG ACC and
uŋə-ne] *ofis mẽ bulaja*
 those.OBL-ACC office.OBL in call.PFV.M.SG

Intended: 'Which teacher caught which student cheating on the exam, the headmaster called, which girl stole the money, that, and them.' [KM MAR.]

There is other evidence that the restriction on the fronting of the MHC is due to the CSC and not some other restriction on movement, such as a restriction on the fronting of one correlative over another. One piece of evidence that this is a restriction on movement out of a coordinated structure is that, in Hindi, only one correlative may be fronted (Bhatt 2003). That is, where there are two, non-coordinated correlative-correlate constituents in a sentence, it is unacceptable to front both of them. (34a), for instance, is an acceptable Hindi sentence while (b), in which both correlatives are raised, is ungrammatical.

- (34) a. *ram ne* [DemP1 [SHC1 *d̄ʒo ləʁka tumhare pit̄h̄e he*]
 Ram ERG which boy you.of behind be.PRS.3.SG
us ləʁke] *ko* [DemP2 [SHC2 *d̄ʒo kitab šantiniketan*
 that.OBL boy.OBL DAT which book Shantiniketan
ne t̄h̄api t̄hi] *vo kitab*] *di*
 ERG print.PFV.F.SG PST.F.SG that book give.PFV.F.SG

'Ram gave, which book Shantiniketan published, that book to, which boy is behind you, that boy.' [HINDI]

- b. * [SHC1 *d̄ʒo ləʁka tumhare pit̄h̄e he*]_i [SHC2 *d̄ʒo kitab*
 which boy you.of behind be.PRS.3.SG which book
šantiniketan ne t̄h̄api t̄hi] *ram ne* [DemP1 *t̄i*
 Shantiniketan ERG print.PFV.F.SG PST.F.SG Ram ERG
us ləʁke] *ko* [DemP2 *t̄j vo kitab*] *di*
 that.OBL boy.OBL DAT that book give.PFV.F.SG

'Ram gave, which book Shantiniketan published, that book to, which boy is behind you, that boy.' [HINDI]

Unlike Hindi, Marwari allows both correlatives to front. For example, (35a) includes two correlative-correlative constituents in argument positions. The fronting of both correlatives as in (35b) is entirely acceptable.

- (35) a. *ram* [SHC1 *d̂zi*ko *t̂horo* *t̂ha* *re lare he*]
 Raam which boy you.HON.OBL behind be.PRS.3.SG
un *t̂hore* *ne* [SHC2 *d̂zi*ki *kitab fantiniketan a*la
 that.OBL boy.OBL ACC which book Shantiniketan one
t̂hapi] *va* *kitab di*
 published that book gave
Lit.: 'Raam gave, which boy is behind you, that boy, which book
 Shantiniketan published, that book.' [OSIAN MAR.]
- b. [SHC2 *d̂zi*ki *kitab fantiniketan a*la *t̂hapi*]
 which book Shantiniketan one published
 [SHC1 *d̂zi*ko *t̂horo* *t̂ha* *re lare he*] *ram*
 which boy you.HON.OBL behind be.PRS.3.SG Raam
t̂i un *t̂hore* *ne* *t̂j va* *kitab di*
 that.OBL boy.OBL ACC that book gave.PFV.F.SG
Lit.: 'Which boy is behind you, which book Shantiniketan published,
 Raam gave that boy that book.' [OSIAN MAR.]

It is even possible to front as many as three correlatives in Marwari. In (36), for example, there are three correlative-correlate pairs. Two of the correlative-correlate constituents are acting as arguments and the other as an adverbial.

- (36) *ramnarayan d̂zi* [SHC1 *un-ro* *p̂arivar d̂ẑat̂he*
 Ramnarayan HON that.OBL-of.M.SG family where
rev̂ato] *ut̂he id̂ẑ* [SHC2 *d̂zin* *ĝĥar m̂e*
 live.IMPFV.m.sg there EMPH which.OBL house in
un-ro *dada-sa* *rev̂ata* *t̂ha*]
 that.OBL-of.M.SG grandfather-sir live.IMPFV.HON PST.M.SG
bo ĝĥar [SHC3 *un-ne* *d̂zi*ko *t̂hori* *daj* *ave*]
 that house that.OBL-ACC which girl liking come.IMPFV.3.SG
un *t̂hori* *re kat̂ar k̂haridijo*
 that.OBL girl.OBL for buy.PFV.M.SG

'In the place where his family lives, Ramnarayan bought the house that his grandfather used to live in for the girl that he loves.'

Lit.: 'Ramnarayan bought which house his grandfather lived in, that house,

where his family lives, there, for which girl he likes, that girl.'

[OSIAN MAR.]

Marwari allows all three of the correlatives in (36) to front, as in (37).

- (37) [SHC1 *un-ro* *pərivar d̪ʒətʰe revəto*] [SHC2 *d̪ʒim*
 that.OBL-of.M.SG family where live.IMPV.m.sg which
gʰər mē un-ro dada-sa? revəta
 house in that.OBL-of.M.SG grandfather-sir live.IMPV.M.HON
tʰa] [SHC3 *un-ne d̪ʒiko tʰori daj ave*]
 PST.M.SG that.OBL-ACC which girl like come.IMPV.3.SG
ramnarajan d̪ʒi t₁ utʰe id̪ʒ t₂ bo gʰər t₃ un tʰori
 Ramnarayan HON there EMPH that house that.OBL girl.OBL
re katər kʰaridijo
 for buy.PFV.M.SG

Lit.: 'Where his family lives, which house his grandfather lived in, which girl he likes, Ramnarayan bought that house for that girl there.' [OSIAN MAR.]

While Marwari allows more than one correlative to front without any apparent restriction, the CSC constraint still holds. A correlative cannot be raised away from the second demonstrative in a conjoined structure, as shown in (38), even if the first correlative is fronted as well.

- (38) * [SHC1 *d̪ʒiki kitab sera likʰi*]_i [SHC2 *d̪ʒika kartun*
 which book Sera write.PFV.F.SG which comic
ʃam bənaja]_j *raʔul ad̪ʒkal* [ConjP *t_i vo ər t_j vo*]
 Sham make.PFV.M.SG Rahul nowadays that and that
pəʃe he
 read.IMPV.M.PL PRS.3.SG

Intended: 'Which book Sera wrote, which comic Sham made, nowadays Rahul is reading that and that.' [OSIAN MAR.]

The inability to front both correlatives from inside a coordinated structure holds for MHCs just as strongly as it does for SHCs. It is not possible for the SHC and the MHC to be fronted when they relate to demonstratives in a coordinated structure (32),.

- (39) * [SHC1 *d̄ʒiki iʰori paja iʰor li*] [SHC2 *d̄ʒiko*
 which girl money stole took.LGT.PFV.F.SG which
marsaʔ d̄ʒim iʰora ne p̄ariksa m̄ n̄kəl karta ne
 teacher which boy.OBL ACC exam in copy do.TA ACC
pakaʀiyo] hed-marsaʔ [ConjP *t̄i va ər t̄j ve*
 catch.PFV.M.SG head-teacher that.F.SG and those.M.PL.OBL
ne] ofis m̄ bulaja
 ACC office in call.PFV.F.SG

Intended: 'Which girl stole the money, which teacher caught which boy cheating on the exam, the headmaster called that and them into his office.'

[MARWARI]

That the MHC cannot be raised away from the plural demonstrative is evidence that it is base-generated within the same constituent as its correlate, just as the SHC is. This means that the MHC and the correlate in the second position of a conjoined structure are both part of the same constituent. Further, that the MHC cannot be fronted, also cannot have been base-generated at IP. This is a strong argument that the MHC can only be base-generated at the demonstrative itself.

The fact that the second correlative is prevented from raising even when Marwari allows more than one correlative to front is evidence that, while the CSC and the restriction on fronting more than one correlative are not as strict in Marwari as they are in Hindi, there are still clear constraints on movement out of a coordinated island.

From this, we can conclude that the correlative, whether SHC or MHC, is base-generated at the demonstrative phrase and cannot be base-generated at IP. Like the SHC, the MHC is part of the same constituent as its plural demonstrative correlate.

While the CSC can only apply to MHC constructions which involve a plural demonstrative correlate, the data in this section supports the argument that the MHC is not actually base-generated at IP but at the demonstrative phrase. Therefore, either the MHC related to multiple demonstratives is a different construction from a MHC related to plural demonstrative, or somehow the MHC is base-generated at the demonstrative phrase just as the other correlatives are. This leads to the question: what does it mean for a

MHC to be part of the same constituent as its correlate when it relates to two demonstratives? I return to this question in Section 7.5 of this chapter.

7.3.4 Binding effects and MHCs

Another method for testing where a correlative is base-generated within a sentence is to look at the binding effects between the correlative and the main clause. Bhatt (2003) shows that a proper name in a SHC which relates to an object demonstrative cannot corefer with a demonstrative in the subject of the main clause. Unfortunately, the binding effects are less clear in the MHC construction than they are for the SHC, and further fieldwork is required to show us what binding effects tells us about the base position of the MHC.

Bhatt (2003) argues that the MHC must be base-generated at IP because a proper name in the MHC may corefer with a demonstrative subject in the main clause. This is illustrated in (40), below.

- (40) [MHC $\widehat{d}z\acute{is}_i-ne$ ram_j ko $\widehat{d}z\acute{is}_k-se$ $dija$]
 which.OBL-ERG Raam ACC which.OBL-DAT give.PFV.M.SG
 us_j-ne us_i-se us_k-ki $tarif$ ki
 that.OBL-ERG that.OBL-DAT that.OBL-of.F.SG praise do.PFV.F.SG
- ‘Who gave Raam to who, Raam praised that giver to that receiver.’
Lit.: ‘Which gave Raam to which, that praised that to that.’ (*from*
 Bhatt 2003, p. 516) [HINDI]

If the MHC were base-generated at the second, direct object demonstrative of the main clause, then the coindexing of Raam and the subject *usne* ‘that ERG’ should be a violation of Condition C. That this is not the case is an indication that the MHC was base-generated above the subject, at IP.

In another example, a quantifier in the subject position of the main clause does not seem to be able to bind a pronoun in the MHC, as (41) shows.

Other examples seem to contradict the restrictions on binding in these examples. An informal query of Hindi speakers, for example, indicates that the demonstrative subject of the main clause of (44) cannot corefer with the proper name in the MHC. (44), therefore, cannot be interpreted as Raam giving away the books.

- (44) * vo_i [_{MHC} $\widehat{d}3is$ $l\check{a}rki$ ne ram_i ki $\widehat{d}3o$ $kitab$
 that which girl.OBL ERG Raam of.F.SG which book
 $p\check{a}r^hi$] us $l\check{a}rki$ ko vo $kitab$ di
 read.PFV.F.SG that.OBL girl.OBL DAT that book give.PFV.F.SG

Intended: 'He, which girl read which of Raam's books, gave that book to that girl.' [HINDI]

Even if the word order shown in (44) were assumed to be a case of the MHC being base-generated at IP and the subject of the main clause being scrambled above it, the subject should still reconstruct to its position within the main clause and therefore be able to corefer with the proper name in the MHC.

It should not be surprising that speaker judgments are so mixed when it comes to binding effects in MHCs. The same kind of hesitation and inconsistency in responses occurred during the initial phases of fieldwork when testing judgments regarding binding effects in SHCs and in extraposed relative clauses. Presenting sentences which involve a violation of binding conditions creates a conflict between the lack of participants for the demonstrative to refer to, a pragmatic restraint, and the syntactic restraint on which participant the demonstrative may take as its referent. In order to resolve this conflict, respondents are willing to consider a grammatical alternative when the syntax failed to produce an acceptable result (Traxler et al. 2002; Crain and Thornton 1998). In other words, asking for judgments related to binding effects without presenting them within a situation which alleviates this conflict is effectively asking the consultant to do their own linguistic analysis, which is not good practice (Matthewson 2006).

The way to resolve this is what I call the *plausible dissent* test. In this approach, the target sentence is presented in a situation which makes more than one participant available as a referent. See Chapter 8, Section 8.4, for a full description of this methodology. This alleviates the inconsistent and hesitant judgments because an alternate, felicitous interpretation is available.

I suggest that the inconsistent judgments with respect to binding effects in MHCs is the same problem. A lack of viable alternatives and a complex syntactic structure means that consultants are more likely to entertain alternative syntactic structures, even ones which contradict the sentence which was actually presented. In order to obtain a more accurate picture of the MHC and binding effects, further fieldwork which incorporates the plausible dissent method of testing is required.

7.3.5 Conclusions

In this section, I have argued that the MHC does not enter the syntax at IP but is base-generated at, at least, the higher demonstrative of the main clause. While certain aspects of the relationship between the MHC and the main clause require further fieldwork, the evidence so far shows that the MHC cannot originate at IP. Not only can the MHC be pronounced inside of the main clause, at the higher demonstrative (the first demonstrative in the linear word order), there are cases in which the MHC cannot front to IP. First, a MHC can be pronounced inside of a relative clause island but a MHC at IP cannot be associated with two demonstratives inside of an island. This is evidence that the fronting of a MHC is a case of movement and not base-generation. Second, it is possible to embed a MHC-plural demonstrative pair inside a coordinated structure. If the MHC is associated with the second coordinate element, it is prohibited from fronting and must be pronounced at the demonstrative itself. This is not only evidence that the MHC is not base-generated at IP but also indicates that the MHC is part of the same constituent as its plural demonstrative correlate.

In the rest of this chapter, I will look at the relationship between the MHC and the demonstrative(s) in the main clause. In Section 7.4, I will present a preliminary analysis of the MHC clause itself, including a discussion of what it might mean for the MHC to be part of the same constituent as the demonstrative phrase.

7.4 A proposed analysis of the MHC Clause

In the analysis which I present here, I assume that the components of the SHC construction have the same lexical entries in the MHC construction. The

wh_{RC} -phrases in the MHC are still composed of a wh -element, NP, and a Q particle Q_{COR} . In the case of the MHC, both Q_{COR} particles raise out of the wh_{RC} -phrase to Spec-CP, where they are conjoined by a pluralizing operator $*$. A MHC in which both Q_{COR} particles have raised, then, has the structure in (45).

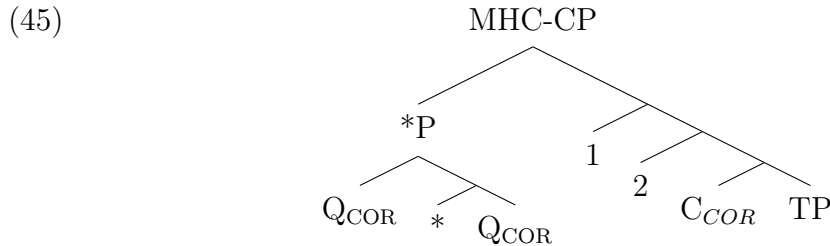

The MHC denotes an ordered pair or set of presupposed individuals of type e , where each member of the ordered pair is then taken as the argument of a demonstrative in the main clause. Syntactically, the MHC is base-generated at the lower demonstrative and moved covertly to the higher demonstrative.

7.4.1 Previous analyses of the MHC

Dayal (1996) concludes that the SHC is the set of properties of a unique individual who satisfies the content of the common noun and the predicate of the correlative. That is, the SHC picks out a unique individual and the set of properties associated with it, and the MC asserts something about this individual. Rather than denoting a set of properties as the SHC does, Dayal (1996, p. 200) concludes that the MHC ‘encodes functional dependencies between wh -expressions just as multiple wh questions do.’

In Chapter 6, Dayal (1996) proposes an analysis for the MHC construction (1), repeated from above.

- (1) $[_{MHC} [_{wh_{RC1}} \widehat{d}z\acute{1}s \quad l\acute{a}\check{r}ki \quad ne]_1 [_{wh_{RC2}} \widehat{d}z\acute{1}s \quad l\acute{a}\check{r}ke$
which girl.OBL ERG which boy.OBL
 $ke \quad sat^h]_2 \quad k^hela \quad] \quad vo_1 \quad us_2-se \quad \widehat{d}z\acute{1}t \quad g\acute{a}ji$
with play.PFV.M.SG that that.OBL-ACC win go.LGT.PFV.F.SG

‘Each girl who played against a boy defeated that boy.’

Lit.: ‘Which girl₁ played which boy₂, (s)he₁ defeated her/him₂.’ (from

Dayal 1996, p. 197)

[HINDI]

Focusing on the MHC $\widehat{d}3is\ l\grave{a}rki\ ne\ \widehat{d}3is\ l\grave{a}rke\ ke\ sai^h\ k^hela$ ‘which girl played which boy’, Dayal assumes that the entire *wh*-phrase raises covertly to Spec-CP, as shown in (46). The subject *wh*_{RC}-phrase $\widehat{d}3is\ l\grave{a}rki$ ‘which girl’ raises first, leaving a functional trace whose a-index is bound by the subject, and then the object *wh*_{RC}-phrase $\widehat{d}3is\ l\grave{a}rke$ ‘which boy’ raises above it.

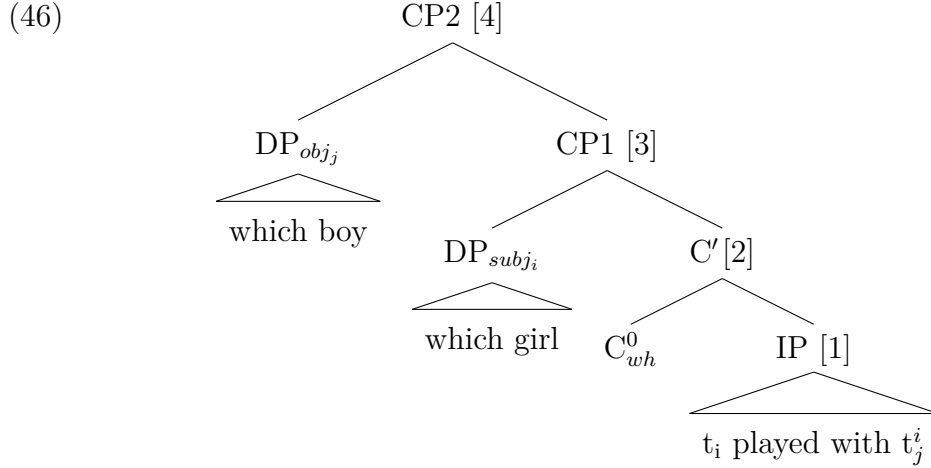

The *wh*-element itself is semantically vacuous but it triggers a +*wh* feature on the complementizer C^0_{+wh} . The *wh*-phrase is interpreted as an ordinary indefinite, and it is the complementizer which does most of the work of interpreting the MHC. Note that C^0_{+wh} is ambiguous with two lexical entries; the first meaning is the one used in SHCs. C^0_{+wh} in MHCs denotes a set of relations rather than a set of properties. Dayal (1996:200) assumes (47) as the lexical entry for C^0_{+wh} in a MHC.

$$(47) \quad \llbracket C^0_{+wh} \rrbracket \\
= \lambda X. \lambda Y. \lambda Z. \lambda R. \exists f' (f' = \iota f [\text{Dom } f = Y \wedge \forall y [Z(f(y))] \wedge \forall y \in Y [X(y)(f)]] \\
\wedge \forall y \in R (y, f'(y)))$$

Where the SHC C^0_{+wh} takes two arguments, C^0_{+wh} in MHCs takes three arguments: the contribution of TP and the contributions of the two *wh*-phrases. The set of relations contributed by C^0_{+wh} is then determined by the relations that hold between members of the domain set and those of the range set. The derivation of the MHC is (48).

$$(48) \quad \llbracket 1 \rrbracket = \llbracket t_i \text{ played with } t_j^i \rrbracket = \llbracket t_i \text{ played with } t_j^i \rrbracket = \text{play-with}'(x_i, f_j(x_i)) \\
\llbracket 2 \rrbracket = \lambda Y \lambda Z \lambda R \exists f' [f' = \iota f [\text{Dom } f = Y \wedge \forall y [Z(f(y))] \wedge \forall Y \in Y [\text{play-with}'(y, f(y))] \\
\wedge \forall y \in Y R(y, f(y))]$$

$$\begin{aligned}
\llbracket \text{DP}_{subj} \rrbracket &= \llbracket \text{which girl} \rrbracket = \text{girl}' \\
\llbracket 3 \rrbracket &= \lambda Z \lambda R \exists f' [f = \iota f [\text{Dom}f = \text{girl}' \wedge \forall y [Z(f(y))] \wedge \forall y \in \text{girl}' [\text{play-with}'(y, f(y))]] \\
&\wedge \forall y \in \text{girl}' R(y, f'(y))] \\
\llbracket \text{DP}_{obj} \rrbracket &= \llbracket \text{which boy} \rrbracket = \text{boy}' \\
\llbracket 4 \rrbracket &= \lambda R \exists f' [f' = \iota f [\text{Dom}f = \text{girl}' \wedge \forall y [\text{boy}'(f(y)) \wedge \forall y \in \text{girl}' [\text{play-with}'(y, f(y))]] \\
&\wedge \forall y \in \text{girl}' R(y, f(y))]
\end{aligned}$$

In order for the correlative clause to combine with the MC in this analysis, the MC must denote a relation. In the case of the MHC construction, this is the relation of *x* defeating *y*.

Gajewski (2008) suggests a slightly different approach as a simplification of Dayal's analysis. Rather than stipulating universal force, the exhaustivity requirement, and the uniqueness requirement through a relation between the domain and the range, Gajewski argues that these readings come from a combination of Heim (1983) style presupposition projection and the contribution of three operators, MAX, iota ι , and Link (1983)'s plurality operator *.

Gajewski notes that in Jacobson (1995)'s analysis of free relatives, the *wh*-phrase does two things. Jacobson assumes that relativization produces a predicate of individuals. First, through the semantics of the relative operator, the predicate is maximalized; the *wh*-element maps a predicate to a predicate that's true of exactly one individual. Secondly, this predicate may or may not be shifted from this singleton set to its member via Partee (1987)'s iota shift.

Rather than assuming that the *wh*-element does both of these things at once, Gajewski assumes that they are done by separate operations, maximalization and iota shift ι . In the rest of this section, I will briefly summarize Gajewski's analysis.

Gajewski (2008) suggests that the structure of the MHC $\widehat{d\acute{z}is} \widehat{l\grave{a}\check{r}ki} \widehat{ne} \widehat{d\acute{z}is} \widehat{l\grave{a}\check{r}ke} \widehat{ke} \widehat{sat^h} \widehat{k^hela}$ 'which girl played which boy' is something like (49).

(49)

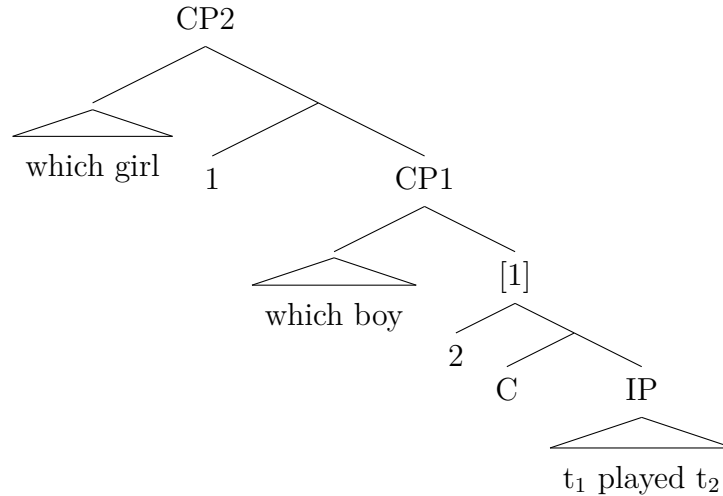

Like Dayal, Gajewski assumes that both of the wh_{RC} -phrases raise covertly, but under his analysis the subject wh -phrase raises first, leaving a simple trace, and the object wh -phrase tucks in underneath of it. C itself makes no semantic contribution. Thus, the semantic contribution of the node at [1] is (50).

(50) $\llbracket [1] \rrbracket = \lambda x.g(1)$ played x

This approach assumes that $\widehat{d\zeta o}/\widehat{d\zeta is}$ ‘which/which.OBL’ is semantically vacuous, but the wh -word triggers the application of maximalization to the first CP dominating it. Thus, MAX enters the syntax above CP1. (Here, $\exists!x$ may be read as ‘there exists a unique x ’.)

(51) a.

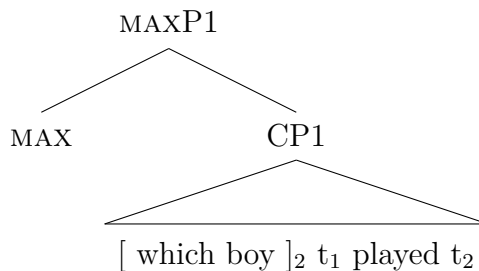

b. $\llbracket MAX \rrbracket = \lambda f:\exists!x[x \in f \wedge \forall y \in f[y \leq x]].\lambda z.z = \sigma x(x \in f \wedge \forall y \in f[y \leq x])$

CP1 is only defined under an assignment g if there is a unique boy that $g(1)$ played. If defined,

(52) $\llbracket CP1 \rrbracket = \lambda x.x$ is the unique boy $g(1)$ played

Looking at the second wh_{RC} -phrase, Gajewski suggests that $\widehat{d\zeta is} \widehat{l\grave{a}rki}$ ‘which girl’ is able to restrict the first coordinate of the CP1 through Chung and Ladusaw (2004)’s Extended Predicate Modification.

(53) Extended Predicate Modification

If α is a branching node whose daughters are β and γ , where $\llbracket\beta\rrbracket \in D_{\langle et \rangle}$ and $\llbracket\gamma\rrbracket \in D_{\langle et \rangle}$, and where T is a conjoinable type, then:

$$\llbracket\alpha\rrbracket = \lambda x. \lambda y. \dots \lambda z. \llbracket\beta\rrbracket(x) = 1 \wedge \llbracket\gamma\rrbracket(x)(y) \dots (z) = 1$$

Gajewski argues that the presupposition of the relative clause (RC) projects a universal presupposition about the domain of the nominal head N . This presupposition projection guarantees that every member of the higher domain, each girl, is matched to some member of the lower domain, some boy.

At this point, before maximality, Link (1983)'s operator $*$ applies. It is for this reason that Gajewski separates MAX from abstraction. Under this approach, $*$ treats a predicate of type $\langle e, \langle et \rangle \rangle$ as a set of ordered pairs, returning a set of sets of ordered pairs as its output, as in (54)

$$(54) \quad *[\lambda x. \lambda y. x \text{ played } y] = (*\{\langle x, y \rangle : x \text{ played } y\} =) \lambda S. S \subseteq \{\langle x, y \rangle : x \text{ played } y\} \wedge S \neq \emptyset$$

The operator MAX , which then applies after $*$, treats $\langle e, \langle et \rangle \rangle$ as sets of ordered pairs, as well, and is defined only if the set contains exactly one ordered pair or if, applied to a set of ordered pair, it picks out the singleton containing the maximal set as its reference. MAX applied to order pair has the semantic contribution (55). Where MAX applies to a single pair, this yields the singleton reading of the MHC.

$$(55) \quad \llbracket MAX_{OP} \rrbracket = \lambda S : \exists! x [x \in S \wedge \forall y [y \leq x]] . \lambda z. z = \sigma x (x \in S \wedge \forall y \in S [y \leq x])$$

Assuming that MAX preserves the ER presupposition associated with the function in (56), if defined, the output set must contain one girl-boy pair for every girl in the domain.

The final structure of the MHC is (56), below.

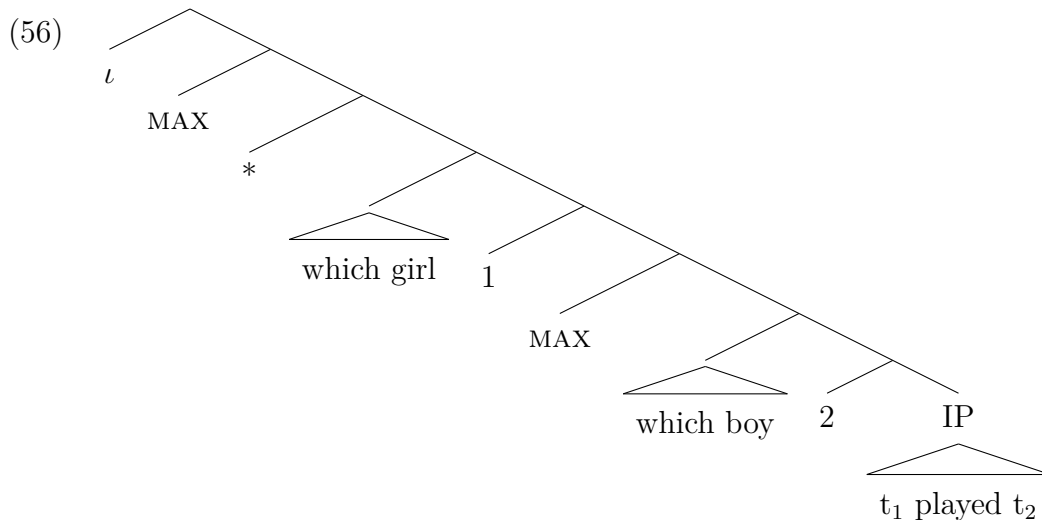

The semantic contribution of the MHC, then, is a set of relations as suggested by Dayal where those relations are defined as (57).

$$(57) \quad \lambda S.S = \{ \langle x, v \rangle : x \text{ is a girl} \wedge y \text{ is the unique boy } x \text{ played with} \}$$

Because of the two demonstratives, the syntax of the MC involves a * operator, as well. Both the MHC and the main clause, therefore, yield a set of relations where the first member of the ordered pair contributed by the MHC relates to the first member of the pair contributed by the main clause, which in turn corresponds to the first or higher demonstrative.

7.4.2 Interpretation of the MHC

I propose an analysis of the MHC in which the correlative clause denotes an ordered pair of two individuals, both of whom are presupposed and unique, defined by the content of the clause. Each of these individuals may then be selected as an argument of the demonstrative in the main clause. The interpretation of the MHC will come from the elements of the *wh*-phrase, which have the same lexical entry as in the SHC, and a pluralizing operator *, similar to that proposed by Gajewski (2008), which conjoins the two Q_{COR} particles at Spec-CP.

In this section, I will present the proposed analysis and show how it applies to the correlative construction (1) discussed by Dayal and Gajewski.

raise to Spec-CP, leaving behind their own traces, to yield the structure in (58).

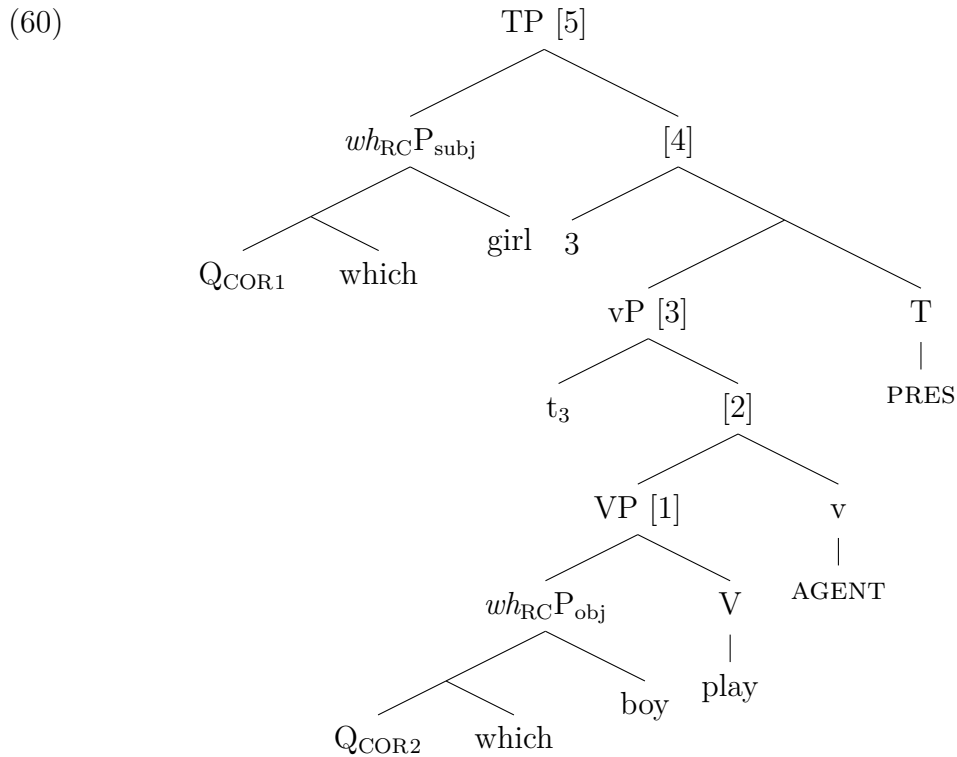

The *wh*-word $\widehat{d\bar{z}is}$ ‘which’ has the lexical entry first defined in Chapter 6, Section 6.4.1, repeated below.

$$(61) \quad \llbracket \text{which} \rrbracket = \lambda x. \lambda f_{\langle et \rangle}. \iota y (y = x \wedge f(y) = 1)$$

Assuming that Q_{COR} has raised, the contribution of the *wh*_{RC}-phrase $\widehat{d\bar{z}is} \text{ l}\bar{a}r\bar{k}e$ ‘which boy’ is (62).

$$(62) \quad \llbracket \text{which boy} \rrbracket = \iota y (y = g(1) \wedge y \text{ is a boy})$$

As noted in Chapter 3, the semantic contribution which I have assumed for the *wh*_{RC}-phrase is similar to Gajewski’s except that, instead of triggering a MAX operator, uniqueness is part of the meaning contributed by the *wh*-word. The *wh*_{RC}-phrase $\widehat{d\bar{z}is} \text{ l}\bar{a}r\bar{k}i \text{ ne}$ ‘which girl.ERG’ will then mean something like ‘the girl $g(2)$ ’.

The meaning of the vP, assuming that the Q_{COR} particles have raised to Spec-CP and left a trace, is then derived as in (63).

- (63) $\llbracket \text{play} \rrbracket = \lambda x. \lambda e. \text{play}(e) \wedge \text{them}(e, x)$
 $\llbracket [1] \rrbracket = \llbracket \text{play} \rrbracket (\llbracket \text{which boy} \rrbracket) = \lambda e. \text{play}(e) \wedge \text{theme}(e, \iota y (y = g(1) \wedge y \text{ is a boy}))$
 $\llbracket \text{AGENT} \rrbracket = \lambda f_{\langle et, st \rangle}. \lambda x. \lambda e. f(e) = 1 \wedge \text{agent}(e, x)$
 $\llbracket [2] \rrbracket = \llbracket v \rrbracket (\llbracket \text{VP} \rrbracket) = \lambda x. \lambda e. \text{play}(e) \wedge \text{theme}(e, \iota y (y = g(1) \wedge y \text{ is a boy})) \wedge \text{agent}(e, x)$
 $\llbracket [3] \rrbracket = \lambda e. \text{play}(e) \wedge \text{theme}(e, \iota y (y = g(1) \wedge y \text{ is a boy})) \wedge \text{agent}(e, g(2))$
 $\llbracket [4] \rrbracket = \lambda x. \lambda e. \text{play}(e) \wedge \text{theme}(e, \iota y (y = g(1) \wedge y \text{ is a boy})) \wedge \text{agent}(e, x)$
 $\llbracket [5] \rrbracket = \llbracket \text{TP} \rrbracket = \lambda e. \text{play}(e) \wedge \text{theme}(e, \iota y (y = g(1) \wedge y \text{ is a boy})) \wedge \text{agent}(e, \iota x (y = g(3) \wedge x \text{ is a girl}))$

The complementizer C, just as in the SHC, takes the set of events contributed by TP and returns a single event of the girl $g(1)$ playing the boy $g(2)$.

- (64) $\llbracket \text{C}_{\text{COR}} \rrbracket = \lambda g_{\langle st \rangle}. \exists e. g(e) = 1$
 $\llbracket [\text{C TP}] \rrbracket = \exists e. \text{play}(e) \wedge \text{theme}(e, \iota y (y = g(1) \wedge y \text{ is a boy})) \wedge \text{agent}(e, \iota x (y = g(3) \wedge x \text{ is a girl}))$

This brings us to the top of the MHC structure, where the conjunction of the two Q particles gives the MHC its interpretation. Each Q_{COR} raises to Spec-CP to become part of the same, conjoined constituent. But, rather than being joined by the more typical conjunction operator \wedge , the two Q_{COR} s are conjoined by the $*$ operator. Much like Gajewski's analysis, $*$ will yield an ordered pair whose members are both of type e.

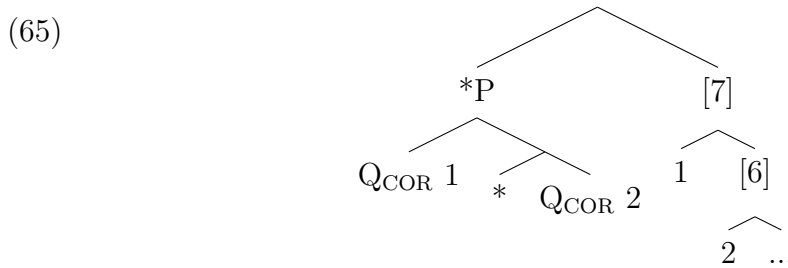

When each Q_{COR} raises to Spec-CP, it triggers a λ -binder which is below the constituent that the Q_{COR} is part of. Because the object Q_{COR} tucks in below the subject Q_{COR} , the λ -binder triggered by the object Q_{COR} is also below the λ -binder triggered by the subject Q_{COR} .⁴

4. In this particular example, the structure of the tree is the same if we assume that the

Each of the λ -binders applies to its sister as we expect. The first λ -binder applies to the C applied to TP and the second λ -binder applies to the output of the first λ -binder.

$$(66) \quad \begin{aligned} \llbracket [3] \rrbracket &= \lambda b. \exists e. \text{play}(e) \wedge \text{theme}(e, \iota y(y=b \wedge y \text{ is a boy})) \wedge \text{agent}(e, \iota x(y=g(3) \\ &\quad \wedge x \text{ is a girl})) \\ \llbracket [4] \rrbracket &= \lambda a. \lambda b. \exists e. \text{play}(e) \wedge \text{theme}(e, \iota y(y=b \wedge y \text{ is a boy})) \wedge \text{agent}(e, \iota x(y=a \\ &\quad \wedge x \text{ is a girl})) \end{aligned}$$

Each of the Q_{COR} components have the same semantic contribution as they do in the SHC.

$$(67) \quad \llbracket Q_{\text{COR}} \rrbracket = \lambda f_{\langle et \rangle}. \iota v(f(v)=1)$$

The conjunction operator $*$ takes the set of elements which are conjoined and yields a set of ordered pairs rather than a plural individual. Defined as in (68), $*$ can take any number of Q_{COR} , maintaining the hierarchal order so that the members of the ordered set are in the order same order as the wh_{RC} -phrases appear in the clause. That is, $*$ takes a set of functions $\lambda f.f(a) = 1$ and yields an ordered set of unique individuals which each bind one of the variables in that function.

$$(68) \quad * \{ \{ (\lambda f. \iota x(f(x)=1))^n \} \} = \lambda f. \langle \iota x_n, \iota x_{n-1}, \iota x_{n-2}, \dots \rangle (f(\dots)(x_{n-1})(x_n)=1)$$

The operator $*$ can only operate over a set of members which are able to be conjoined. In this case, multiple Q_{COR} particles can only conjoin if the function that defines them is the same. If the functions are different, then $*P$ is undefined.

In a MHC $\widehat{d\acute{z}is} \text{ l}\acute{a}\check{r}ki \text{ ne } \widehat{d\acute{z}is} \text{ l}\acute{a}\check{r}ke \text{ ke sat}^h \text{ k}^h\text{ela}$ ‘which girl played which boy’ which involves two relative phrases, there are two coordinated Q_{COR} particles in $*P$. The derivation of $*P$ in the construction (1) is (69).

$$(69) \quad \begin{aligned} \llbracket *P \rrbracket &= *(\lambda f. \iota u(f(u) = 1), \lambda f. \iota v(f(v) = 1)) \\ &= \langle \iota u, \iota v \rangle \lambda f. (f(v)(u) = 1) \end{aligned}$$

object Q_{COR} raises first and the subject Q_{COR} raises second and enters the conjunction above it. The λ -binder triggered by the subject Q_{COR} may then enter the syntax immediately below the $*P$ constituent which includes the subject Q_{COR} . I have chosen to assume, instead, that the subject Q_{COR} raises first so that the analysis of the MHC is more similar to what is commonly assumed for multiple wh questions. This may also have implications for languages whose wh_{RC} -phrases do not raise covertly.

The ordering preserves the scopal relations between the two functions, so that the individual contributed by the subject comes before the individual contributed by the object. *P then takes the output of the λ -binders as its argument.

$$\begin{aligned}
(70) \quad \llbracket *P \rrbracket(\llbracket 5 \rrbracket) &= \llbracket \text{which girl played which boy} \rrbracket = \\
&= \lambda f. \langle \iota u, \iota v \rangle (f(v)(u) = 1) (\lambda a. \lambda b. \exists e. \text{play}(e) \wedge \text{theme}(e, \iota y (y = b \wedge y \text{ is a boy})) \wedge \\
&\quad \text{agent}(e, \iota x (y = a \wedge x \text{ is a girl}))) \\
&= \langle \iota u, \iota v \rangle (\lambda a. \lambda b. \exists e. \text{play}(e) \wedge \text{theme}(e, \iota y (y = b \wedge y \text{ is a boy})) \wedge \\
&\quad \text{agent}(e, \iota x (y = a \wedge x \text{ is a girl}))) (v)(u) \\
&= \langle \iota u, \iota v \rangle (\lambda b. \exists e. \text{play}(e) \wedge \text{theme}(e, \iota y (y = b \wedge y \text{ is a boy})) \wedge \\
&\quad \text{agent}(e, \iota x (y = u \wedge x \text{ is a girl}))) (v) \\
&= \langle \iota u, \iota v \rangle (\exists e. \text{play}(e) \wedge \text{theme}(e, \iota y (y = v \wedge y \text{ is a boy})) \wedge \\
&\quad \text{agent}(e, \iota x (y = u \wedge x \text{ is a girl})))
\end{aligned}$$

The meaning of the MHC in (1) is the two unique individuals v and u such that there is an event e and v played u in e . (70) may be simplified to (71).

$$(71) \quad \langle \iota u, \iota v \rangle (\exists e. \text{the girl } u \text{ played against the boy } v)$$

What does it mean for the correlative to denote an ordered pair? The MHC denotes a set which includes two definites individuals. Rather than this set being a plural individual made up of distinct, separate individuals, the members of this set remain distinct.

In order for the members of the set to be ordered, there must be some kind of asymmetry between them. I suggest that the ordered pair in (69) may be defined as the set containing two members with the semantic contribution in (72).

$$\begin{aligned}
(72) \quad \langle \iota u, \iota v \rangle (\exists e. u \text{ played } v \text{ in } e) \\
&= \{ \iota u (\exists v. \exists e. \text{play}(e) \wedge \text{theme}(e, \iota y (y = v \wedge y \text{ is a boy})) \wedge \\
&\quad \text{agent}(e, \iota x (x = u \wedge x \text{ is a girl}))), \iota v (\exists e. \text{play}(e) \wedge \\
&\quad \text{theme}(e, \iota y (y = v \wedge y \text{ is a boy})) \wedge \text{agent}(e, \iota x (x = u \wedge x \text{ is a girl}))) \}
\end{aligned}$$

To make the contribution of the * operator clear, this may be simplified as:

$$\begin{aligned}
(73) \quad \langle \iota u, \iota v \rangle (\exists e. \text{the girl } u \text{ played the boy } v \text{ in } e) \\
&= \{ \iota u (\exists v. \exists e. \text{the girl } u \text{ played the boy } v \text{ in } e), \iota v (\exists e. \text{the girl } u \text{ played the} \\
&\quad \text{boy } v \text{ in } e) \}
\end{aligned}$$

The asymmetry in the ordered pair arises from the fact that the first member of the pair must scope over the second member of the pair in order for all instances of the variable *a* to be bound. The members of the MHC are roughly ‘the unique individual *u* such that there is an event *e* and an individual *v*, where the girl *u* played a game against the boy *v* in *e*, and the unique such that there is an event *e* and the girl *u* played a game against the boy *v* in *e*’.

7.5 The MHC and its correlates

In Section 7.3, I showed that the MHC is not base-generated at IP but enters the syntax either immediately preceding the higher demonstrative or below. In this section, I outline a proposal which assumes that the MHC has the same underlying features as the SHC and is also the spell-out of the indices of its demonstrative. The syntax of the full MHC construction will follow from the elements which we have already seen in the SHC: the ability of an index to be overtly spelled out, the conjunction operator ***, and the ability of the index to be moved away from its base position. While the semantic analysis I propose here will be somewhat stipulative, I believe that it brings us closer to a unified theory of SHCs and MHCs and, importantly, demonstrates that it is possible for the MHC to be built from the same underlying features as the SHC.

Through the CSC, we have seen that, if the MHC relates to a plural demonstrative, then both the demonstrative are base-generated as part of the same constituent. If the MHC is a variation of the SHC construction, then it stands to reason that the MHC acts as the index of the demonstrative. If this is the case, what is the relationship between the MHC and the lower demonstrative? Recall the correlative construction being considered, repeated below.

- (1) [MHC $\widehat{d}3is$ *lark* *ne* $\widehat{d}3is$ *lark* *ke sat^h k^hela*]
which girl.OBL *ERG* *which boy.OBL* *with* *play.PFV.M.SG*
vo us-se $\widehat{d}3it$ *gaji*
that that.OBL-ACC *win* *go.LGT.PFV.F.SG*

Lit.: ‘Which girl₁ played which boy₂, (s)he₁ defeated her/him₂.’ (*from*
 Dayal 1996, p. 197) [HINDI]

Because the MHC denotes an ordered set of individuals, a singular demonstrative cannot take a MHC as its index. If the demonstrative subject *vo*

‘that’ were to take the correlative *d̂ʒis ləɾki ne d̂ʒis ləɾke ke sat^h k^hela* ‘which girl played with boy’, the interpretation of (1) would be that the girl and the boy defeated some other individual who is the referent of the object demonstrative. Further, there would be a conflict between the number of the MHC and the single number marking on the subject.

One possible approach is to assume that the MHC is adjoined to the higher demonstrative, as Wali (1982) and Bhatt (2003) assume for the SHC. This leads to the same issues which arose for the SHC under this type of analysis. First, it is unclear what would restrict the MHC from adjoining elsewhere, at a position which is not adjacent to a demonstrative, such as above other DPs or even at IP. Second, if the MHC adjoins to either DemP, this leaves open the question of the relationship between the demonstrative and the *wh*_{RC}-phrases. That a fronted MHC cannot be fronted out of a relative clause island shows that the relationship between the MHC and the demonstrative is not a binding relationship.

The second possibility is that the MHC is base-generated as the index of the higher demonstrative. This would align more closely with the analysis of SHC and would allow the second *wh*-phrase, or second individual denoted by the MHC, to bind the lower demonstrative. In this section, I show that a MHC cannot relate to a demonstrative inside of an island, even if it also relates to a higher demonstrative outside of the island. This means that the relationship between the MHC and the lower demonstrative is also not binding.

A final possibility, and the analysis that I assume here, is that the MHC is the spell out of the indices of both demonstrative simultaneously, where those indices have raised out of the correlative clause to a position just above the higher demonstrative. The MHC clause may then be moved away from this position to the left periphery. While this approach will require a bit of stipulation in order to come to the right semantic interpretation, it unites the SHC and the MHC constructions in a way that other analyses have been unable to do, the relationship between the MHC and its associated demonstratives follows naturally from the other elements of the construction, and this analysis accounts for all of the data regarding binding and islands presented in this section.

7.5.1 The MHC does not bind the lower demonstrative

As shown in Section 7.3 of this chapter and Section 2.2.2 of Chapter 2, post-nominal relative clause phrases are islands for overt movement. A SHC or MHC may be base-generated at a demonstrative (or pair of demonstratives) inside of a RC island, but the correlative clause may not be moved out of the island to a fronted position.

In (74), we see that RC Islands are also islands for covert movement. While Marwari is an in-situ language, the *wh_Q* or its Q-particle cannot raise to LF for question interpretation.

- (74) * *mē vo kitab* [_{RC} *d̄ʒo kuŋ lik^hijo*] *daj*
 I that book which who? write.PFV.M.SG liking
ave
 come.IMPFV.PRS.3.SG

Intended: ‘Who is such that I like the book which they wrote?’ [MARWARI]

If a MHC is base-generated at the higher demonstrative, whether adjoined above the demonstrative or as an overtly pronounced index, then a MHC construction in which the lower demonstrative is inside of a RC island is expected to be grammatical. For example, in (75) the MHC *d̄ʒin kisan re paṛ d̄ʒako gəḍo he* ‘which farmer owns which donkey’ can only relate the demonstrative phrases *bo (kisan)* ‘which (farmer)’, the subject of the main clause, and *bo gəḍo* ‘that donkey’, embedded inside of the RC Island.

- (75) * [_{MHC} *d̄ʒin kisan re paṛ d̄ʒako gəḍo he*]
 which.OBL farmer.OBL near which donkey be.PRS.3.SG
bo (kisan) kamro [_{RC} *d̄ʒin mē bo gəḍo*
 that.M.SG (farmer) room which_{RC} in that.M.SG donkey
reve] *borijo*
 live.IMPFV.3.SG sweep.PFV.M.SG

Intended: ‘Which farmer owns which donkey, that (farmer) swept the room/stall which that donkey lives in.’ [MARWARI]

This is not possible, though. A MHC outside of the RC Island, even if it is associated with a higher demonstrative phrase outside of the island, cannot relate to a demonstrative phrase inside of the RC island. Yet, as (76) shows,

there is no restriction which prevents a DP inside the correlative clause from relating to the demonstrative inside of the island.

- (76) [S_HC *d̂ʒɪn kɪsən re paɾ ek gaɖo he*] *bo*
 which farmer.OBL near one/a donkey PRS.3.SG that.M.SG
un kəmre ne [R_C *d̂ʒɪn mē bo gaɖo*
 that.OBL.SG room.OBL.M.SG ACC which in that donkey
reve] *borijo*
 live.IMPFV.3.SG sweep.PFV.M.SG

'Which farmer owns a donkey, he swept the stable which that donkey lives in.'
 [MARWARI]

The relationship between the MHC and the lower demonstrative phrase cannot, therefore, be a case of binding. If it were, (75) would be grammatical.

There are other examples of the same restriction in Marwari, such as (77).

- (77) * [M_HC *d̂ʒəko laɖu un- ri mā d̂ʒəka iʃ^hora*
 which ladus that of.F mother which boy.M.SG.OBL for
re vaste bəŋaijo] *ba və laɖu t^hali mē*
 make.PFV.M.SG that.F.SG those.M.PL ladus plate in which_{RC}
 [R_C *jəko un iʃ^hora ne heŋ ũ bəɖiya*
 that.OBL boy.OBL.M.SG DAT all from great feel.IMPFV.3.SG
lage] *g^haliya*
 put.PFV.F.SG

Intended: 'Which ladus which boy's mother made, she put those ladus on (the) plate which that boy likes most of all.'
 [MARWARI]

Again, the only correlates which the MHC could relate to are a demonstrative inside the main clause and a demonstrative embedded in a RC island.

The fact that these examples are ungrammatical indicates that there is a movement relationship between the two demonstratives. The MHC, or at least some part of it, must move between the two demonstratives before being spelled out at the higher demonstrative. In the next section, I present an analysis of the MHC which assumes that the indices of both demonstratives raise to a position just above the higher demonstrative. These indices are then spelled out as the MHC. It is the movement of the lower demonstrative to the

position above the higher demonstrative which is blocked by the relative clause island.

7.5.2 The MHC as an overt spell out of both indices

Rather than assuming that the MHC binds either of its demonstrative correlates, I propose an analysis in which the MHC is the spell out of both of the indices simultaneously. Under this approach, both indices move away from their respective demonstrative, before spell out, to a position above the higher demonstrative. There, they are conjoined by the same conjunction operator (*) seen in the derivation of the MHC clause. I also give a preliminary analysis of the semantic interpretation of the MHC in relation to its demonstratives.

In Section 7.4, I argued that the MHC denotes an order pair of individuals, so that the MHC in a construction like (1) has the meaning in (73, repeated from above).

(73) $\{\iota u(\exists v.\exists e.\text{the girl } u \text{ played the boy } v \text{ in } e), \iota v(\exists e.\text{the girl } u \text{ played the boy } v \text{ in } e)\}$

The main clause of the MHC construction in (1) includes two demonstrative phrases, each of which has its own index and relation projection.

(78) *vo us-se d̂ʒit gaji*
 that that.OBL-ACC win go.LGT.PFV.F.SG

'That defeated that.'

[MARWARI]

The clause (78) has the structure shown in (79), where the NP projection of each demonstrative is shown as a covert noun phrase.

(79)

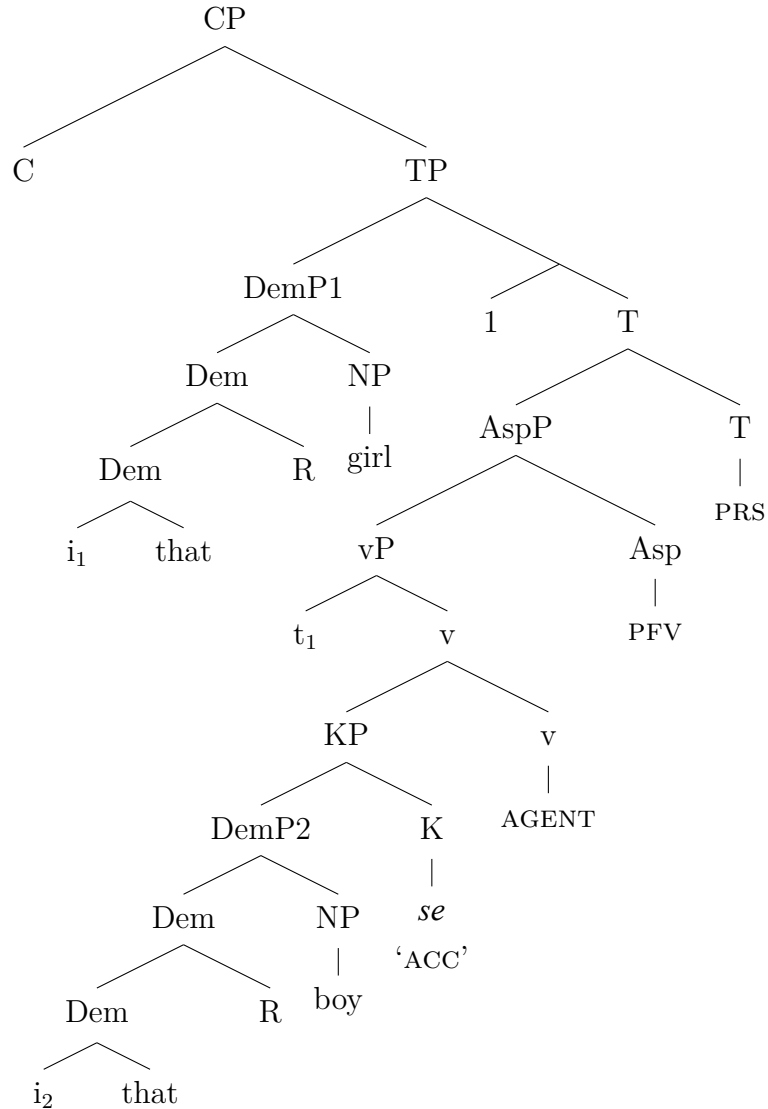

Clearly, the MHC cannot be the spell-out of both indices simultaneously, at least not in this configuration. Yet, in order for the MHC construction to be interpreted correctly, the MHC must act as the spell out of both indices, but in such a way that each individual contributed by the MHC is interpreted in a different position.

I posit that both indices raise out of their position within each respective demonstrative phrase to a position just above the higher demonstrative.

We already know from the SHC construction that MIA languages allow an overtly pronounced index to raise out of the demonstrative phrase. This analysis assumes that the index does not have to be spelled out in order to raise. Further, I will assume that both indices raise to a single head and are conjoined by the conjunction operator * – the same conjunction operator

proposed for the interpretation of the MHC clause. The main clause of the MHC construction will then have the structure shown in (80).

(80)

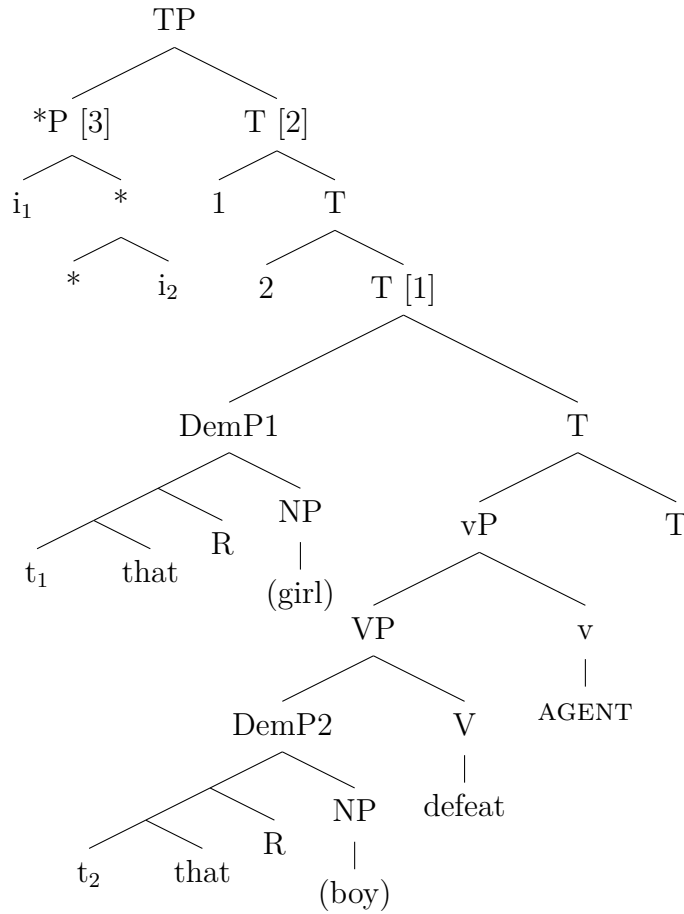

I have ignored the movement of the subject from Spec-vP to Spec-T in this tree so that the traces left by the movement of the indices and the resulting λ -binders are clear.

The MHC, which denotes an order pair of individuals, then enters the syntax as the overt pronunciation of *P, which is also an ordered pair. A MHC with two associated demonstratives in subject and object position, therefore, has the structure in (81), below.

(81)

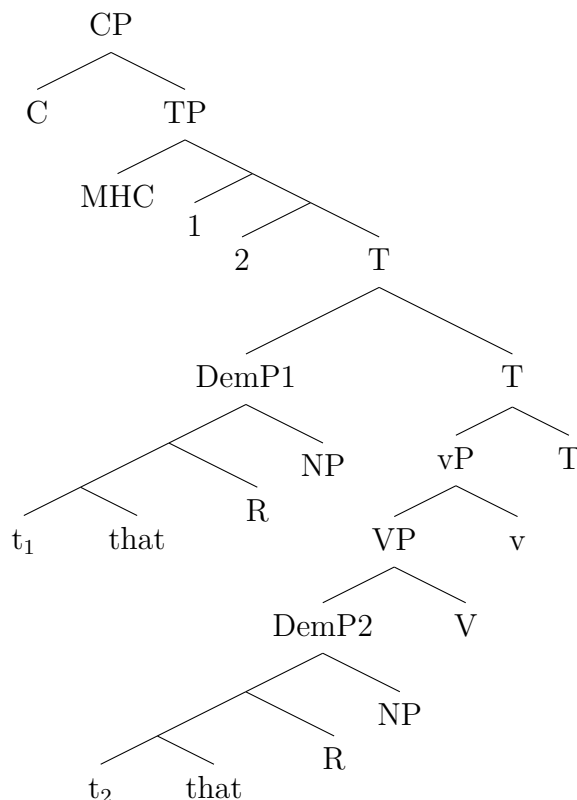

The adverbial MHC construction will have the same structure. Recall from Chapter 5 that the index of all demonstratives, including adverbial demonstratives, is an entity of type *e*. Further, even when the *wh*-phrase is adverbial, the SHC denotes an individual of type *e*. Similarly, for the adverbial MHC construction, the index of the adverbial demonstratives is the same as the index found in nominal demonstratives. A MHC involving adverbial demonstratives denotes an ordered pair of entities of type *e*. The index of the adverbial demonstrative, therefore, raises to the same *P position as seen in the nominal MHC construction with no additional mechanism required. Thus, the availability of adverbial, mixed, and mismatched MHC constructions follows directly from the components of the demonstrative phrase itself.

Before moving on, I should note that there are two reasons why I assume that the indices do not raise to the spine of CP directly. First, Hindi only allows one correlative to raise even if there are multiple correlative-correlate constituents in a sentence (Section 7.3.3). I take this to mean that there is only one position which the index can raise to, at least in Hindi. Secondly, if both indices raise to the spine, it is not clear how they could be spelled out as a single phrase (the MHC). Under this approach, the MHC will act as the spell out of *P, where *P denotes an ordered pair of indices which have yet to

be interpreted.

Having shown how the MHC construction is structured syntactically, I now turn to its semantic interpretation. First, (82) shows the semantic contribution of the main clause up to T at node [1] in the structure (80). Both indices have raised to a position above the higher demonstrative, leaving behind a trace.

$$(82) \quad \llbracket [1] \rrbracket \\ = \lambda e. \text{defeat}(e) \wedge \text{theme}(e, \iota y (y = g(2) \wedge y \text{ is a boy} \wedge \text{DIST}(y, a, t))) \\ \wedge \text{agent}(e, \iota x (x = g(1) \wedge x \text{ is a girl} \wedge \text{DIST}(x, a, t)))$$

The movement of each index triggers a λ -binder along the CP-spine. The node above the higher λ -binder, node [2] of (80), has the semantic contribution 83).

$$(83) \quad \llbracket [2] \rrbracket = \\ \lambda a. \lambda b. \lambda e. \text{defeat}(e) \wedge \text{theme}(e, \iota y (y = b \wedge y \text{ is a boy} \wedge \text{DIST}(y, a, t))) \\ \wedge \text{agent}(e, \iota x (x = a \wedge x \text{ is a girl} \wedge \text{DIST}(x, a, t)))$$

Like the raising of the Q particle Q_{COR} , the index associated with the higher demonstrative raises first and the second index raises and ‘tucks in’ underneath it. Because the lower index tucks in beneath the higher index in the conjunction phrase *P, the second λ -binder also tucks in beneath the λ -binder triggered by the higher index. This maintains the hierarchy between the two entities denoted by the MHC and will allow the first individual denoted by the MHC to be interpreted at the higher demonstrative.

An alternative analysis to the tucking in of the second index might be to consider this a case of *undermerge*. Undermerge is phrasal movement in which the moved phrase is a complement of a probing head H^0 (Pesetsky 2007, 2013; Yuan 2017).



In the case of the MHC construction, it is the * operator which is driving the movement of the indices.

Another related construction is the extraposed relative with a split antecedent. In (85), for example, the two referents *everyman* and *every woman* both relate to the relative clause *who* came in together.

(85) Every woman is smiling and every man is frowning who came in together.

Fox and Johnson (2016) suggest that (85) has the structure in (86). The extraposed relative sits within the higher, otherwise unpronounced, copy of the NP which has been moved by QR (NP_{copy}). NP_{copy} is composed of the two subject NPs which have raised via QR into a single, higher QP.

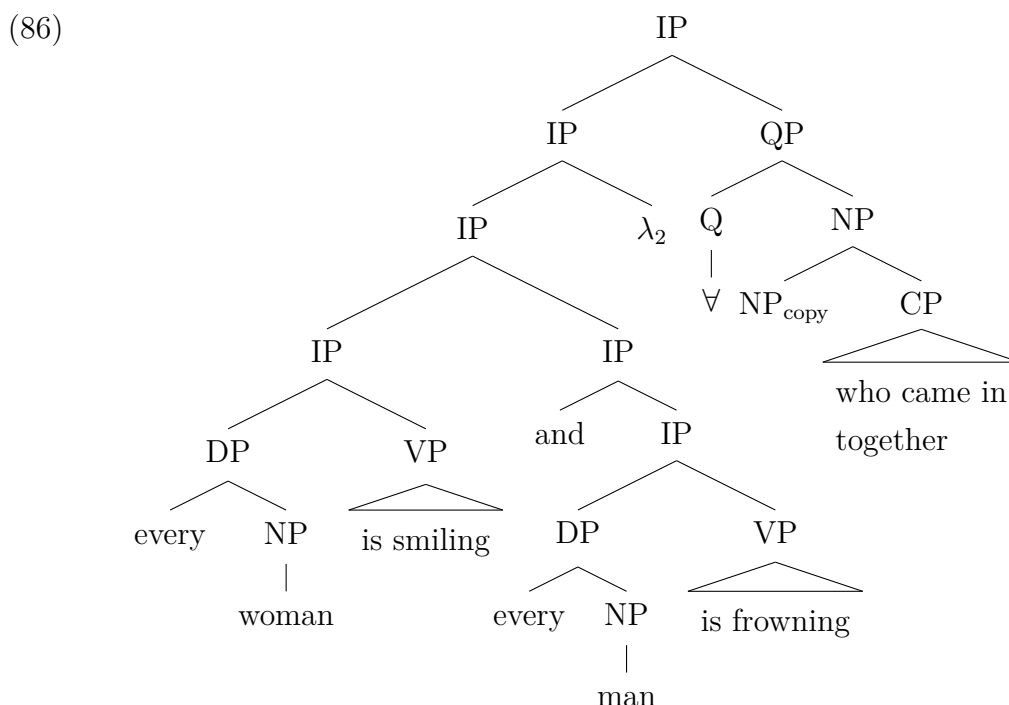

The difference between (85) and a correlative construction, of course, is that the MHC is interpreted at two different positions in the main clause whereas the extraposed relative which related to a split antecedent interprets both NPs at a single position. But, this does show that the MHC is not unique in having two entities interpreted at a single position or in having movement which targets the complement position of a head.

When the indices move, they have not received an interpretation. Once both indices have moved to $*P$, the ordered pair denoted by $*P$ is then spelled out as the MHC, which itself denotes a set of two ordered individuals, ιu and ιv . The meaning of $*P$, therefore, is the meaning contributed by the MHC (50, repeated from above).

(50) $[[*P]] = [[\text{which girl played which boy}]]$
 $= \langle \iota u, \iota v \rangle (\exists e. \text{the girl } u \text{ played against the boy } v)$ [Simplified]

Once *P has been spelled out, in order for the sentence to receive the correct interpretation, it is necessary that the two individuals contributed by the MHC be interpreted at two different positions. Secondly, because of the two λ -binders, the main clause denotes a function of type $\langle e, \langle e, st \rangle \rangle$, or of type $\langle e, et \rangle$ if we were to set aside situations. This is a function from individuals to characteristic functions. This means that the function at node [2] of (81) needs to be able to take an ordered pair as an argument where it would normally take two entities which each enter the syntax independently.

In order for a function from individuals to characteristic functions to be able to take an ordered pair as an argument, I propose a new semantic rule: *The interpretation of ordered pairs.*

(87) **The interpretation of ordered pairs**

Given an ordered pair of individuals of type e $\langle u, v \rangle$ and a function f , where f is a function including variables a and b and is a function from individuals to characteristics of type $\langle e, \langle e, t \rangle \rangle$, then:

$$\lambda a. \lambda b. f(a, b)(\langle u, v \rangle)$$

may be interpreted as:

$$\lambda a. \lambda b. f(a, b)(v)(u)$$

That is, in order to apply a function to an ordered pair, the function applies first to the first member of the ordered pair and then to the second member of the ordered pair.

To see how this works, consider a simplified semantic composition of the sentence being considered. I have left aside, for the moment, events and all of the meaning contributed by the demonstrative except for the index. The simplified semantic contribution of node [2] is (88), where (88) will take the ordered pair in (89) as an argument.

(88) $\llbracket [2] \rrbracket$
 $= \lambda a. \lambda b. a$ defeated b in e

(89) $\llbracket \text{MHC} \rrbracket =$
 $\langle \iota u, \iota v \rangle (\text{the girl } u \text{ played against the boy } v)$

Using the rule (87), applying (88) to (89) means that the function contributed by the two λ -binders will apply first to the first member of the ordered pair and then to the second member of the ordered pair, as shown in (90).

(90) $\lambda a. \lambda b. a \text{ defeated } b \llbracket \langle \iota u, \iota v \rangle (\text{the girl } u \text{ played the boy } v) \rrbracket$

According to the definition of $*$: $= \lambda a. \lambda b. a \text{ defeated } b \llbracket \langle \iota u (\exists v. \text{the girl } u \text{ played the boy } v), \iota v (\exists e. \text{the girl } u \text{ played against the boy } v) \rangle \rrbracket$

According to the rule *Interpretation of ordered pairs*:
 $= \lambda a. \lambda b. a \text{ defeated } b (\iota v (\text{the girl } u \text{ played the boy } v)) (\iota u (\exists v. \text{the girl } u \text{ played against the boy } v))$

The function $\lambda a. \lambda b. a \text{ defeated } b$ applies to the first member of the ordered pair first, yielding the following composition.

(91) $\lambda b. \iota u (\exists v. \text{the girl } u \text{ played against the boy } v) \text{ defeated } b (\iota v (\exists e. \text{the girl } u \text{ played against the boy } v))$

The second λ -binder then applies to the second member of the ordered pair, so that the full MHC construction has the following (simplified) contribution.

(92) $\iota u (\exists v. \text{the girl } u \text{ played against the boy } v) \text{ defeated } \iota v (\text{the girl } u \text{ played against the boy } v)$

This means that the correlative construction in (1), roughly, has the interpretation in (93).

(93) *There is a unique individual u such that the girl u played against the boy v and there is a unique individual v such that v was played against by the girl u , and u defeated v .*

The non-simplified version looks more complicated because it also involves events and the information contributed by the demonstrative, including the relation contributed by R and information regarding proximity, but it works in the same way. Look again at the function contributed by the two λ -binders (83, repeated below).

$$(83) \quad \llbracket 2 \rrbracket = \\ \lambda a. \lambda b. \lambda e. \text{defeat}(e) \wedge \text{theme}(e, \iota y (y=b \wedge y \text{ is a boy} \wedge \text{DIST}(y, a, t))) \\ \wedge \text{agent}(e, \iota x (x=a \wedge x \text{ is a girl} \wedge \text{DIST}(x, a, t)))$$

The contribution of the MHC is repeated in (72, repeated from above).

$$(72) \quad \{ \iota u (\exists v. \exists e. \text{play}(e) \wedge \text{theme}(e, \iota y (y = v \wedge y \text{ is a boy})) \wedge \\ \text{agent}(e, \iota x (x = u \wedge x \text{ is a girl}))), \iota v (\exists e. \text{play}(e) \wedge \\ \text{theme}(e, \iota y (y = v \wedge y \text{ is a boy})) \wedge \text{agent}(e, \iota x (x = u \wedge x \text{ is a girl}))) \}$$

This is the two individuals contributed by the multi-headed correlative: the girl who played against a boy in some event e' , and the boy who was played against by some girl in some event e' . For the moment, I am going to call these two individuals GIRL and BOY, which are defined as follows.

$$(94) \quad \llbracket \text{GIRL} \rrbracket = \iota u (\exists v. \exists e'. \text{play}(e') \wedge \text{theme}(e, \iota b (b = v \wedge a \text{ is a boy})) \wedge \\ \text{agent}(e, \iota a (a = u \wedge a \text{ is a girl}))) \\ \llbracket \text{BOY} \rrbracket = \iota v (\exists e'. \text{play}(e') \wedge \text{theme}(e', \iota b (b = v \wedge b \text{ is a boy})) \wedge \\ \text{agent}(e', \iota a (a = u \wedge a \text{ is a girl})))$$

The contribution of the MHC is therefore equivalent to (95), below.

$$(95) \quad \langle \llbracket \text{GIRL} \rrbracket, \llbracket \text{BOY} \rrbracket \rangle$$

The function in (83) will then apply to the meaning contributed by the MHC. According to the rule *Interpretation of ordered pairs*, (83) applied to (72) is equivalent to (96).

$$(96) \quad \lambda a. \lambda b. \lambda e. \text{defeat}(e) \wedge \text{theme}(e, \iota y (y=b \wedge y \text{ is a boy} \wedge \text{DIST}(y, a, t))) \\ \wedge \text{agent}(e, \iota x (x=a \wedge x \text{ is a girl} \wedge \text{DIST}(x, a, t))) (\langle \llbracket \text{GIRL} \rrbracket, \llbracket \text{BOY} \rrbracket \rangle) \\ = \lambda a. \lambda b. \lambda e. \text{defeat}(e) \wedge \text{theme}(e, \iota y (y=b \wedge y \text{ is a boy} \wedge \text{DIST}(y, a, t))) \\ \wedge \text{agent}(e, \iota x (x=a \wedge x \text{ is a girl} \wedge \text{DIST}(x, a, t))) (\llbracket \text{BOY} \rrbracket) (\llbracket \text{GIRL} \rrbracket)$$

That is, first the function (83) applies to the first member of the ordered pair, $\llbracket \text{GIRL} \rrbracket$, as shown below.

$$(97) \quad \lambda b. \lambda e. \text{defeat}(e) \wedge \text{theme}(e, \iota y (y=b \wedge y \text{ is a boy} \wedge \text{DIST}(y, a, t))) \\ \wedge \text{agent}(e, \iota x (x=\llbracket \text{GIRL} \rrbracket \wedge x \text{ is a girl} \wedge \text{DIST}(\llbracket \text{GIRL} \rrbracket, a, t))) (\llbracket \text{BOY} \rrbracket)$$

Then, the function applies to the second member of the ordered pair, $\llbracket \text{BOY} \rrbracket$.

- (98) $\lambda e.\text{defeat}(e) \wedge \text{theme}(e, \iota y(y = \llbracket \text{BOY} \rrbracket) \wedge y \text{ is a boy} \wedge \text{DIST}(\llbracket \text{BOY} \rrbracket, a, t))$
 $\wedge \text{agent}(e, \iota x(x = \llbracket \text{GIRL} \rrbracket) \wedge x \text{ is a girl} \wedge \text{DIST}(\llbracket \text{GIRL} \rrbracket, a, t))$

Replacing $\llbracket \text{GIRL} \rrbracket$ and $\llbracket \text{BOY} \rrbracket$ with their denotation, the contribution of the MHC construction (1, repeated below) is (99). The contribution of the MHC is underlined in order to make it more clear where each element in the semantic contribution came from. Note that, even though the MHC is one phrase, each of the individuals contributed by the MHC is interpreted in a different position due to the traces left by the moved indices.

- (1) $[\text{MHC} [\widehat{d}\bar{z}is \quad l\bar{a}rki \quad \quad \quad ne \quad]_1 [\widehat{d}\bar{z}is \quad l\bar{a}rke_2 \quad \quad \quad ke \text{ sat}^h \quad]$
which girl.F.SG.OBL ERG which boy.M.SG.OBL with
k^hela] vo₁ us₂-se d̄z̄it gaji
play.PFV.M.SG that that.OBL-ACC win go.LGT.PFV.F.SG

'Each girl who played against a boy defeated that boy.'

Lit.: 'Which girl₁ played which boy₂, (s)he₁ defeated her/him₂.' (*from*

Dayal 1996, p. 197)

[HINDI]

- (99) $\llbracket \text{which girl played which boy, that defeated that} \rrbracket$
 $= \lambda e.\text{defeat}(e) \wedge \text{theme}(e, \iota y(y = \iota v(\exists e'.\text{play}(e')$
 $\wedge \text{theme}(e', \iota b(b = v \wedge b \text{ is a boy})) \wedge \text{agent}(e', \iota a(a = u \wedge a \text{ is a girl})))$
 $\wedge y \text{ is a boy} \wedge \text{DIST}(\iota v(\exists e'.\text{play}(e') \wedge \text{theme}(e', \iota b(b = v \wedge b \text{ is a boy}))$
 $\wedge \text{agent}(e', \iota a(a = u \wedge a \text{ is a girl}))), a', t))$
 $\wedge \text{agent}(e, \iota x(x = \iota u(\exists v.\exists e'.\text{play}(e') \wedge \text{theme}(e, \iota b(b = v \wedge a \text{ is a boy}))$
 $\wedge \text{agent}(e', \iota a(a = u \wedge a \text{ is a girl}))))$
 $\wedge x \text{ is a girl} \wedge \text{DIST}(\iota u(\exists v.\exists e'.\text{play}(e') \wedge \text{theme}(e, \iota b(b = v \wedge a \text{ is a boy}))$
 $\wedge \text{agent}(e', \iota a(a = u \wedge a \text{ is a girl}))), a', t))$

While (99) looks quite complicated, it contributes basically the same information as (92) along with information about the proximity of the boy and girl who played against one another and information about the two events, e and e' . (99) has the following (rough) interpretation.

- (100) *Given an event e , the distal girl in e (who is the girl who played a boy in some event e') defeated the distal boy in e (who is the boy who was played by a girl in e').*

The same analysis will apply to the adverbial MHC construction except that the two indices will raise from inside of an adverbial demonstrative to conjoin at *P. *P will then be spelled out as an adverbial MHC.

The use of a rule for the interpretation of the ordered pair is, admittedly, somewhat stipulative. While it would have been preferable to have an analysis of the MHC which follows entirely from the elements already present within the syntactic structure and semantic contribution of the SHC or elsewhere in the syntax, the analysis presented here shows that it is possible to have an analysis of the MHC construction which follows from the components of the SHC. The relationship between the individuals contributed by the MHC, therefore, have the same relationship as the SHC to its correlate, that of an overtly pronounced index. This analysis also account for the other syntactic features of the MHC discussed in this section. The movement of the two indices means that the MHC cannot relate to two correlates which are separated by an island for movement, such as a postnominal relative clause island. That the MHC is base-generated, not at IP, but immediately above the higher demonstrative also means that the MHC cannot front out of an island for movement but must remain at its base position adjacent to the first demonstrative.

7.5.3 The order of demonstratives in Marwari

There is an apparent difference between the Marwari and Hindi MHC construction which, if it holds true, may require a slightly different analysis for the Marwari MHC. In Section 1.3, I discussed the relationship between the MHC and the demonstrative in the main clause and presented some of Dayal (1996)'s examples which show that, in Hindi, the order of the demonstratives in the main clause must correspond to the order of the wh_{RC} -phrases in the MHC.

There are several cases in Marwari which pattern with the Hindi. The interpretation of the Marwari (101) is the same as the equivalent Hindi sentence, given in (9).

- (101) [MHC *d̥ʒako d̥gdər₁ d̥ʒɪn b^hemar₂ ne dek^hijo*]
 which doctor.M.SG which patient ACC see.PFV.M.SG
vo₁ un₂-ne paja dija
 that that.OBL-ACC money.M.PL give.PFV.M.PL

'Which doctor saw which patient, that (doctor) gave that (patient) money.'

[MARWARI]

Like the Hindi example, (101) can only be interpreted as the doctor giving the patient money (as shown with subscripts). In fact, if the NP component of the demonstratives overtly tries to force the opposite reading, as in (102), the sentence is ungrammatical.

- (102) * [MHC *d̥ʒako d̥gdər d̥ʒɪn b^hemar ne dek^hijo*]
 which doctor..M.SG which patient ACC see.PFV.M.SG
vo d̥gdər un b^hemar ne paja dija
 that doctor that.OBL patient ACC money.M.PL give.PFV.M.PL

Intended: 'Which doctor saw which patient, that patient gave that doctor money.'

[MARWARI]

While some correlative constructions in Marwari seem to align with the judgments for Hindi, there are other examples in which the order of the demonstratives may be reversed. In (103), for example, the order of the demonstratives is the reverse of the order of the *wh_{RC}*-phrases in the MHC.

- (103) [MHC *d̥ʒako i^horo d̥ʒɪn i^hori re hat^e*
 which boy.M.SG which.OBL girl.OBL.F.SG with
r̥amijo] ba un-ne harajo
 play.PFV.M.SG that.F.SG that.OBL-ACC defeat.PFV.M.SG

'Which boy played against which girl, she defeated him.' [MARWARI]

The construction in (103) is acceptable and must mean that the girl defeated the boy. If the subject of the main clause is *bo* 'that.M.SG', then this is interpreted as the boy defeating the girl.

Unlike Hindi, Marwari demonstratives are marked for gender. The reversibility of the demonstratives seems to relate to the gender marking of the demonstrative, but this is not always the case. In (104), for instance, both demonstratives are masculine and yet they may still be reversed.

- (104) [*d̥ʒəko kəndoi d̥ʒəko hiro bəŋaijo*]
 which chef which sweet.dish.M.SG make.PFV.M.SG
vo hiro un kəndoi re matʰe
 that.M.SG sweet.dish.M.SG that.OBL chef.OBL on
pəɾ go
 fall go.LGT.PFV.M.SG

‘Which chef made which sweet dish, that sweet dish fell on that chef.’

[MARWARI]

Contrast this with the (105), which is basically the same construction except that the demonstratives are bare.

- (105) a. ?[*d̥ʒəko kəndoi d̥ʒəko hiro bəŋaijo*]
 which chef which sweet.dish.M.SG make.PFV.M.SG
vo un-re matʰe pəɾ go
 that.M.SG that.OBL-on fall go.LGT.PFV.M.SG

‘Which chef made which sweet dish, that fell on that.’

[MARWARI]

- b. ?[[*d̥ʒəko hiro*]_i *d̥ʒəko kəndoi t_i bəŋaijo*]
 which sweet.dish.M.SG which chef make.PFV.M.SG
vo un-re matʰe pəɾ go
 that.M.SG that.OBL-on fall go.LGT.PFV.M.SG

‘Which chef made which sweet dish, that fell on that.’

[MARWARI]

Marwari speakers were shown two different pictures. In one picture, a chef has fallen on top of a spilled dish of *hiro*, a sweet dish made of carrots and milk. In the other picture, a bowl of *hiro* has fallen onto the chef’s head. The consultants were then given the sentences in (105) and asked whether that sentence was true for each picture.

The first response of both consultants was that (105a) means that the *hiro* fell on top of the chef, and that (105b) is true of the picture in which the chef fell on the *hiro*. After some discussion, the consultants decided that (105a) can also mean that the chef fell on top of the bowl of *hiro*. They ultimately decided that both sentences are degraded because it is not clear from the sentence whether the *hiro* fell or the chef fell.

How do we account for the apparent differences between the order of demonstratives in a Marwari MHC construction and in a Hindi MHC construction? The analysis of the MHC clause (Section 7.4.2) could easily be revised so that the Marwari correlative denotes a set of unordered members (i.e., a conjunction operator like ‘and’) where the Hindi MHC would still yield an ordered pair. Revising the analysis in this way would allow for the interpretations suggested for (104) and (105). On the other hand, such an analysis would not be able to account for examples like (101) and (102), in which the speaker judgments were very clear in disallowing the reversal of the two demonstratives. (101), for instance, could only be true in a situation where the doctor was paying the patient.

While these are only a few examples, and further fieldwork is required before making any definite conclusions, I suggest that the ambiguity in speaker judgments regarding the order of the demonstratives is analogous to the inconsistency in speaker judgments related to the binding effects. The testing of several similar constructions in a row combined with a natural tendency to assume that sentences are interpretable may also have contributed to the speakers flexibility in entertaining an alternative analysis. In this case, I believe that better testing methods will result in more consistent judgments which will probably show that the interpretation of MHC constructions where it relates to the order of the demonstratives is actually the same for Marwari as it is in Hindi. Therefore, for now, I will assume that the analysis in Section 7.4.2 applies to both languages.

7.6 Conclusion

On the surface, the MHC construction appears to be quite different from the SHC construction. The MHC involves two or more *wh*-phrases, where the SHC only includes one, and the MHC appears to always appear at the left periphery even when the SHC is base-generated adjacent to its demonstrative correlate (see Chapter 2). For this reason, the MHC has often been thought of as a distinct construction from the SHC.

In Section 7.2, I showed that the MHC construction shares many of the same syntactic features as the SHC construction. Further, Section 7.3 presented new evidence that the MHC is not base-generated at IP but must be base-generated, at the highest, adjacent to the higher demonstrative or corre-

late phrase.

Because the MHC is syntactically similar to the SHC, including the fact that it is base-generated inside of the main clause, I propose that the availability of the MHC construction follows directly from the same components found in the SHC construction – namely, the ability of an index to be overtly pronounced and the availability of a *wh*-clause headed by a relative phrase. These features are necessary, then, for the MHC to be available in a language, but they are not sufficient. The MHC also requires the availability of the * conjunction operator and the ability of the index to move away from the associated demonstrative phrase. If a language were to block the movement of the index, then it should also block the availability of the MHC construction. A language must also allow a multiple-headed free relative type construction (the MHC clause itself), which in turn relies on the availability of the conjunction operator *. Further, in Chapter 6 I argued that the correlative construction is closely related to other *wh*-clauses such as question. I predict that, in languages which do not allow multiple-*wh* questions, the MHC construction will not be available. The fact that the MHC construction is built on the same features as the SHC construction not only links the two constructions but also gives us insight into the relationship between the demonstrative and its index.

There is an important difference between the SHC construction and the MHC construction, though. While the SHC can be pronounced at its base-generated position, the MHC must be able to overtly spell out two indices which are not part of the same constituent in their base position. This analysis assumes that the MHC is the overt pronunciation of the indices of its correlates, but these indices have raised from their base position to join the conjunction phrase *P. The MHC is, therefore, the overt pronunciation of *P.

In order to interpret the MHC construction, I propose a new rule: *Interpretation of ordered pairs*. Simply put, this rule states that, given a list of ordered individuals, a function applies first to the first individual in the ordered pair and then to the second individual.

While I have not discussed the pair-list reading of the MHC construction here, I assume that the pair-list reading comes from a combination of the definite interpretation of the MHC and the scope relations that hold between the two *wh*-phrases and the two indices of the demonstrative correlates. That scope relationship is maintained by the conjunction operator *P, which yields a set of ordered individuals rather than an unordered set of atoms.

This analysis can easily be extended to more than two *wh*-phrases and demonstratives. The conjunction operator $*$ is able to conjoin any number of elements, whether that be Q_{COR} -particles within the MHC or indices in the main clause.

Chapter 8

Methods: Interpreting unfamiliar constructions

8.1 The purpose of this chapter

There are two reasons for including a discussion of fieldwork methodology as part of this dissertation. The first reason is that, as a non-native speaker of Hindi and someone who does not speak Marwari at all, I feel that it is important to show how the data presented in this dissertation was acquired.

The second reason for writing this chapter is to contribute toward the ongoing discussion of proper methodology in semantics fieldwork. One of my hopes through this research is to not only to contribute to a better understanding of the syntax and semantics of Hindi and Marwari, but also to encourage other researchers that it is possible to do rigorous syntactic and semantic research in less documented and unfamiliar languages. While it is standard in anthropology and sociology to talk about all aspects of one's fieldwork experience, this is not something which is usually done in formal linguistics (Macaulay 2012). According to Louis (2015), '[p]rior to Matthewson (2004), the general consensus was that semantics fieldwork on something other than the investigator's native language was impossible – that is, that one had to be a native speaker of the target language in order to access the sort of intuitions required for formal semantic analysis'. There are, of course, exceptions to this and significant work has been done in these areas by researchers who are not native speakers of the language that they are investigating, but this type of research remains a minority.

In Section 8.2, I briefly describe the language varieties being investigated in this research with some comments on the advantages of doing fieldwork in separate, short trips rather than one long field trip.

One of the challenges in researching an unknown language is eliciting new data and obtaining accurate grammaticality judgments. Section 8.3 includes a discussion of techniques which I found helpful and some of the limitations of those methods.

While certain techniques and methods are useful for getting at grammaticality judgments, they are less useful in understanding the semantic contribution of sentences. In Section 8.4 and Section 8.5, I discuss two of the tests related to semantic fieldwork. Section 8.4 presents a new method for obtaining accurate judgments regarding binding effects, particularly violations of Condition C, which I call the *plausible dissent* method. This method is inspired by Crain and Thornton (1998)'s methodology used in studying language acquisition in children.

The second semantic methodology to be discussed is testing for presuppositions. Incorporating methods outlined by Matthewson (2006), I outline the methodology used to show that correlatives do, in fact, carry a presupposition of uniqueness (see Chapter 6).

8.2 An overview of Hindi/Marwari fieldwork

Fieldwork related to this dissertation was conducted in three parts. Overall, I was able to commit approximately 14 weeks to fieldwork in Marwari over the course of the three field trips, and I spent approximately nine weeks doing fieldwork in Hindi.

The first stage fieldwork was over a period of about 10 weeks, during which time I alternated between Delhi and Jodhpur, Rajasthan. Approximately half of this time was spent working with Hafiz, my primary Hindi informant, in Delhi, where I was living at the time. The other half of this period was spent in Jodhpur, Rajasthan, working with Kartik, one of my primary Marwari consultants, and two other consultants from Jodhpur city. During this trip, I worked with my Marwari consultants to document the basics of Marwari grammar and to gather preliminary data on relative clauses and correlatives in Marwari.

The second stage fieldwork was again approximately two months (8 weeks),

again alternating between Delhi and Jodhpur. During my time in Delhi, I worked primarily with Mukesh, working for about two hours a day. In Jodhpur, I again worked with Kartik as well as three other informants from Jodhpur District.

The third and final stage of fieldwork was near the end of my dissertation, and consisted of approximately five weeks spent entirely in Jodhpur city. During this particular field trip, Kartik was only able to work with me a few hours a week, but introduced me to another Marwari speaker, Sunil, who became my second primary informant in Marwari. During this trip, I was able to work with these two speakers, as well as four other Marwari speakers including the two Marwari speakers from Osian.

Over the course of this fieldwork, I was able to work with one primary Hindi speaker, Mukesh, and to double check that data with other native speakers of Hindi from Delhi.

During Marwari fieldwork, I was not always able to work with the same speakers consistently and was often limited by who was available. One restriction was simply the amount of time I could expect anyone consultant to work with me per day. Having multiple consultants allowed me to have multiple sessions per day, with different speakers. Having multiple speakers did present some challenges, though. One challenge was having to deal with variation. Not all speakers were from the same region, and varieties differed. This meant rechecking sentences already elicited to see where the varieties differed, and also meant that more time was spent training consultants in giving grammaticality judgments (see Section 8.3).

A second limitation on how much work we were able to do was the availability of consultants; all of my consultants had other commitments such as work and school which we had to schedule our sessions around. Sessions also occasionally had to be cancelled because of *bandhs* (city-wide strikes) or because consultants had other commitments which they had to attend to. (See Macaulay (2012) for a discussion of how these limitations often arise during fieldwork.)

There are pros and cons to doing fieldwork in short trips rather than one long field trip. First, it was more expensive to have to make multiple trips to the field in order to conduct research. There was a non-financial cost, as well; doing the my fieldwork over three trips was that the consultants who I worked with on previous trips were not always available to work with me again.

Despite these considerations, I believe that the benefits of this approach outweighed the costs. Being able to do two months of research and then turn to analyzing that data allowed me to have a clearer picture of what was happening within each language before returning to the field. If fieldwork had involved only one trip, then I would have had to spend more downtime on the field in order to process the data or I would have had to gather as much data as possible and hope that I had what I needed to support or disprove an analysis later. Secondly, because I was only on the field for a few weeks at a time, I feel like my consultants made themselves more available than they would have if I had been in Jodhpur in Delhi for the full six months at one time. Especially during my third trip, because my consultants knew that I was only in Jodhpur for a limited time and that I needed to get as much data as possible, they were willing to work for more hours a day than I would normally have asked of them, and they were willing to meet with me quite regularly. Being able to process the previously collected data also gave me more time to prepare for our sessions, allowing us to work more efficiently while I was on the field. If I had been in Jodhpur for a longer time, we would not have been able to sustain this level of intensity.

Before proceeding, I feel like it is important to include the relevant information about the researcher herself. Before beginning my fieldwork in Rajasthan, I had been living in Delhi for four years while studying for my Master's degree and doing other studies. I am a native American English speaker and, including my studies at Jawaharlal Nehru University (JNU), all of my education from childhood has been in English. I learned some Hindi while living in Delhi, but only speak it to a conversational level, and I struggle to understand Hindi in group conversations. While I am able to construct sentences in Hindi, none of the judgments presented throughout this research are mine and all have been checked by native speakers.

Understanding Hindi was useful, allowing me to accelerate my research into Hindi correlatives because I already had a basic understanding of Hindi grammar. Knowing Hindi was also useful in my research on Marwari and widened the pool of potential consultants. Because most of my Marwari consultants were not proficient in English, translating from Hindi to Marwari was much more straightforward than translating from English. Translating directly from Hindi was also helpful when dealing with constructions which are not available in English, such as correlatives.

8.3 Eliciting accurate grammaticality judgments

To the native researcher, it seems like getting accurate grammaticality judgments should be pretty straightforward, but all of us who have had to learn to give fine-tuned judgments, even in our own language, know that this is not actually the case. In this section, I briefly discuss some of the techniques that I used to elicit clear, accurate grammaticality judgments in Hindi and Marwari. The first reason for this discussion is to reinforce the grammaticality judgments given throughout this dissertation, and to give some of the methodology for how those judgments were reached. The second reason is that, hopefully, some of these observations and techniques will be useful for other linguists doing research in a language which they do not speak themselves. It is possible to get accurate data in a language which you do not actually speak, and when your only available consultants are linguistically naive.

It is well established within linguistic fieldwork that it is not good methodology to ask your consultants to do linguistic analysis (Abbi 2001; Matthewson 2004; Bochnak and Matthewson 2015). One danger is that consultants will do their own analysis and base their judgments on that analysis, rather than intuition. All of us have a certain internal understanding of how their language works, accurate or not. When someone is aware of what is being tested it is very easy for them to apply their analysis to their judgments rather than relying on their own native speaker instincts. The other complication of speakers trying to do analysis is that they will often refer back to standardized, prescriptive approaches to language and analyze the grammaticality of the statement according to the rules that they were taught in school instead of whether it is felicitous in natural conversation.

Another pitfall to be aware of in eliciting grammaticality judgments is that consultants may not understand what it is that you want from them. An example of this is judgments regarding binding effects discussed in Section 8.4. Judgments can involve more than one variable which can affect consultants' responses. Speakers may be responding according to whether a sentence is grammatical, whether it is pragmatically feasible, or even whether all of the words are Marwari words (Crain and Thornton 1998). In these cases, responses may appear inconsistent. This is because the consultant may not necessarily be answering the question that the researcher intended to ask.

In this section, I discuss some of the elicitation methods I used throughout

the research. Some of these methods are more appropriate at certain stages of the research project than they are at others. Elicitation through translation (Section 8.3.1), for instance, is useful at the beginning stages of researching an unfamiliar language but should be used sparingly later on. Section 8.3.2 discusses some of the techniques for requesting grammaticality judgments and how consultants responded to those.

One non-translational method of elicitation is Schlenker's number scale (Section 8.3.3). While this type of scale is not familiar in Marwari culture, this technique still proved useful in giving consultants a way to indicate that a sentence was questionable.

Finally, Section 8.3.5 discusses the importance of clearly delineating tasks so that what the researcher expects from a given activity is clear.

This section is only a brief discussion of elicitation methods. For a more in depth discussion of obtaining information about a language and its structure, see Mosel (2012).

8.3.1 Eliciting through translation

There are a few different ways to begin building up a corpus or a preliminary list of sentences and vocabulary. From there, the linguist can build the target sentences that they are particularly interested in studying. In a language like Hindi, which is well documented, a wide variety of sentences and analysis in written grammars, dictionaries, books for teaching Hindi, formal papers, and a wide variety of literature (both written and spoken) are easily available. While it is still important to make sure that you are describing the same variety that you are written or corpus data came from, these sentences and vocabulary items can be used to build more complex sentences or sentences of the variety that the researcher is interested in.

It is a bit more difficult to begin building up a basic grammar and vocabulary for an unfamiliar or less familiar language such as Marwari, which has very little written about it and which does not have such a broad variety of literature or teaching materials available.¹ A helpful way build up a basic grammar and vocabulary list is to begin by translating simple sentences, either from English or from a closely related, better documented language such as

1. While limited, there are some Marwari resources available. First, Magier (1983) discusses the tense-aspect system of Marwari in depth. There is also a magazine published in Marwari, Manak Rajasthani Magazine.

Hindi. Because Marwari is related to Hindi and the speakers I worked with were more familiar with Hindi than with English, starting from Hindi examples meant that the translation into Marwari was more precise. Having a wide variety of Hindi materials available also allowed me to translate directly from the examples presented in papers like Dayal (1996) and Bhatt (1997, 2003). Once the researcher has a basic idea of the grammar and enough vocabulary to start constructing sentences, then this data can be used to build more complex sentences or to test different word orders in the target language.

Generally, when translating into the target language, the sentences will be grammatically accurate. There are a few exceptions to this, though. One way in which a translation can be inaccurate is when a consultant is translating a sentence word for word. Working with a language which is related to the target language and which has a similar underlying word order is one way to mitigate this problem. It also helps to either check the sentences with more than one consultant or to work with more than one consultant at a time, as they will often discuss what is the most accurate translation and correct one another if there is a problem.

Another way in which a translation may be inaccurate is if the consultant does not fully understand the language the sentences initially given it. During my fieldwork, this was particularly a problem when source sentences were in English. Even if my consultants spoke English or went to an English medium school, they often were not fluent enough in English to understand some of the more nuanced differences between the two languages. This was especially true in things like tense and aspect, the grammaticality of questions, definiteness (because Hindi and Marwari do not have definite articles), and certain vocabulary items like quantifiers.

Some of these problems will become more apparent as the researcher becomes more familiar with the language and can identify those points at which the translation given by the consultant does not precisely reflect the sentence which is being translated. This is also where being familiar with Hindi was useful because, even though Marwari and Hindi are different in many ways, their vocabulary and grammar are very similar allowing me to guess when a translation might not be accurate and further investigation is required.

8.3.2 Eliciting grammaticality judgments

Eliciting grammaticality judgments often involves asking the consultant whether the sentence is acceptable or not (Majid 2012; Mosel 2012). This is a useful tool, and can be helpful when trying to establish the basic word order or the grammar of a simple sentence in order to look at more complex sentences. But, there are certain considerations which must be taken into account which the researcher needs to be aware of before relying on elicited data for analysis.

In order for a consultant to be able to give accurate grammaticality judgments, some training is required. While many linguists within the Western education have spent a great deal of time thinking about what it means for a sentence to be a grammatical or not, this kind of reflection and analysis has not been a part of everyone's education. For many people, it is not natural to think about whether the way that we speak is grammatical or not, and this may be a very foreign and strange concept for a consultant. Initially, many of my consultants felt like I was asking them to gauge whether a sentence was grammatical according to prescriptive or standardized rules. This was especially a problem in Hindi, which is the medium of education for a large majority of people in North India and which is more standardized than Marwari is. Even though natural speech differs in many ways from *kitab-Hindi* (book-Hindi), when my consultants gave judgments it was according to what they expected a textbook to say was grammatical. For my Marwari consultants, they were more aware that Marwari was going to be different from Hindi, but there were still occasions when they would judge a Marwari sentence according to prescriptive Hindi grammar.

For most consultants, coming to an understanding of what I, the researcher, was looking for grammaticality judgments usually just involved explaining that I am not interested in book-Hindi or in how a textbook says that Marwari should be spoken, but I want to know how people really speak and whether a sentence is something that they themselves would say. I would then start off working with a consultant using simple sentences and asking them whether the sentence was grammatical or not. At one point, in the final stage of fieldwork, I did have a few new consultants join and made the mistake of asking them to give grammaticality judgments for more complex sentences such as correlative clauses and embedded sentences without having done any of the more simple sentences as a sort of training. This was a mistake, and made it difficult for them to know exactly what it was that I was asking for. In the end, it was

necessary to pause elicitation and go over several practice sentences before attempting any new grammaticality judgments.

Another common problem when asking for grammaticality judgments was when consultants focused on vocabulary rather than grammaticality. In these cases, a consultant would judge a sentence as acceptable or good Marwari because ‘every word is a Marwari word’. When this happened, especially early on, it was important to confirm that the vocabulary is important and then to ask the speaker to judge the sentence as a whole. This approach acknowledged that both correct vocabulary and grammar are important without embarrassing the consultant for not understanding what exactly I was asking for. As I made fewer mistakes, this issue became less common.

Another aspect of communicating clearly with the consultant is the way that grammaticality judgments are requested. Below, I discuss some of the approaches I used for requesting judgments, some of which worked well and some of which did not.

This is something which is clearly going to vary by culture and by the expectations of the people that you are working with. The anecdotes that I am mentioning here will not necessarily apply to every situation but are things which I found helpful or unhelpful during the course of my own research.

8.3.2.1 Can I say it this way?

During the initial stages of research in Hindi, I would often ask my consultant, ‘Can I say this?’ Then, I would present them with the target sentence. On one particular occasion, when testing scrambling in Hindi, I noticed that my consultant was saying that every variation was acceptable, even variations which I expected to be ungrammatical. I stopped and asked my consultant, ‘Are you sure that I can say this in Hindi?’

He said, ‘Of course you can say that. You can say anything that you want. It does not mean anything, but you can say it.’

What I thought I was asking was, ‘Is this a good sentence in Hindi?’ My consultant interpreted what I asked as meaning, ‘Do I have permission to say this?’ His response was probably also tempered by boredom, as I had made the mistake of testing several sentences which varied only slightly. When eliciting judgments, therefore, it is important to be aware that there will be occasions on which the people who are willing to spend time helping you learn their language or about their language will often avoid criticizing your progress.

As a new speaker of Hindi, I had probably made several ridiculous sentences during our conversations. Rather than discouraging my attempts, he was gracious enough to encourage my relatively poor Hindi. Sufficeth to say, this was not a good method for obtaining grammaticality judgments and how the researcher asks for judgments needs to be more explicit.

8.3.2.2 Can your grandmother say it this way?

Instead of asking a consultant if they can say a sentence a certain way, another approach I attempted was to ask, ‘Could your grandmother say it this way?’ There were a few reasons for asking this way. One was the assumption that the language of older generations will have undergone less change than the variety spoken by younger generations. In a country like India, where education is more and more available to young people, it is also much more likely that a young person will have had more contact with languages of education such as Hindi and English. Contact with these languages may have affected their variety of Marwari. In Rajasthan, it is also likely that a grandparent will be living in a village or a rural area where the language is more homogenous. In remote areas, it is also less likely that there will contact with other varieties due to migration and interaction with other communities.

This seemed like a fairly straightforward way to help a consultant think through whether a sentence which you have given is something which a Marwari person would say. Unfortunately, when I asked Marwari speakers this question, it did not go as well as expected. I attempted this on an occasions when I was working with two different Marwari consultants. On giving the target Marwari sentence, I asked both speakers whether their grandmother could say the target sentence this way. Both consultants looked somewhat confused, but they both said that yes, this was something that their grandmother would say. The third time I asked the same thing about a sentence, one of the consultants turned to me and said, ‘Why do you keep asking about my grandmother? You do not even know my grandmother.’

I later learned that, while it is quite common in Delhi to ask about someone’s family even if you have never met them, in Marwari culture it is actually considered rude to ask about someone’s family or relations if you have never actually met them in person. Because I had not met any of my consultants’ family members, including their grandmothers, they actually found this method of questioning very strange, if not disrespectful. Thankfully, they

gave me the benefit of the doubt that, as a foreigner, I did not know better.

8.3.2.3 Is this good Marwari?

A more helpful way to ask whether a sentence was grammatical or not was to ask, ‘Is this good Marwari?’ In many ways, this was a good way to ask whether sentence was acceptable or not, particularly if I was listening for the consultants reasons for considering a grammatical or not.

Occasionally, a speaker will respond with something like, ‘Some people can say it that way.’ In these cases, I would ask the consultants whether this is something that they themselves can say, explaining that, while I am interested in all varieties of Marwari, what I am particularly interested in is how they themselves talk. Often, further discussion revealed that what they actually meant was that a sentence sounded okay, but was not quite right, or was wrong in some way but they could not quite identify how.

This is not only a problem in Marwari, of course, or with linguistically naive speakers. I have heard English speakers and linguists give similar responses for much the same reasons. Even when checking for grammaticality in English sentences, respondents will often reply with, ‘I am sure there are some people who can say it that way’, or ‘That sounds like something they would say in a book or something’. In these particular cases, if the speaker’s judgment was that a sentence is acceptable for some people but they themselves cannot say it, I considered the sentence ungrammatical. The consultant may be correct that there are some speakers for whom this particular sentence is grammatical, but it may also be the case that the sentence is ungrammatical but still interpretable. In either case, I can only describe the grammar of my consultants themselves.

8.3.2.4 Is this a good sentence for you? Can you say it this way?

Another way of asking if the sentence is grammatical is simply to ask the consultant, ‘Can you say the sentence this way?’ Responses probably vary across cultures, but throughout the course of this fieldwork, I found that this question and the question ‘Is this good Marwari?’ were the most likely to get consistent, clear grammaticality judgments. None of my consultants found the question offensive, nor did I feel like the fact that they had been exposed to other languages and even spoke other languages fluently had influenced their

ability to give judgments about Marwari itself.

8.3.3 Other methods of testing grammaticality: Number scale

Another method of asking for grammaticality judgments is having consultants with grade sentences on a scale of 1 to 7, where seven is the best Marwari and one is a sentence which is not Marwari at all.

Schlenker (2013), Schlenker (2014), and Schlenker et al. (2016) suggest this particular method for grammaticality judgments. Using the number scale, Schlenker tested sentences across consultants and on several different occasions with the same consultant. In his methodology, he used the average score of a sentence to determine whether the sentence received a *, ?, ??, etc. Under his analysis, anything above a four or so was considered grammatical. Anything between 3.1 and 4.2 received a ?.

This method was not quite as straightforward during my own fieldwork in Marwari, but it still proved to be very useful. I only tried this method at the end of my fieldwork, so it was only tested with four consultants. One of these consultants was still unwilling to judge a sentence as ungrammatical, and his grammaticality judgments ultimately had to be set aside.² The first step in using this method was to explain to my consultants the grading scale and the kinds of judgments that I was looking for. Grading things like acceptability on a scale was a concept which was very unfamiliar for my Marwari consultants, and they wanted me to explain precisely what each step of the scale was intended to mean. Together, we came up with a system with numbers associated with smiling or frowning faces, where one meant a sentence was not Marwari at all, in any way, and a seven meant a sentence was the best Marwari.

In my research, the number which my consultants gave to a sentence was not precise enough to make the kind of precise distinctions that Schlenker was able to make. The number scale was most helpful, not in quantifying the acceptability of the sentence, but in giving my consultants a way to show that a sentence was ungrammatical without actually having to say that it is wrong. Working with more than one consultant at once also allowed them to discuss their judgments and why it was that they chose that particular point on the

2. At one point, this consultant graded a sentence as 6 on a 7 point scale. When asked why it was a 6, he said, 'Because I can't understand it at all.'

scale. As it turned out, seven was generally used to indicate that a sentence was fully grammatical. A six generally meant that either there was something wrong with the sentence, but they were not quite sure what it was, or that they were able to think of a better, more felicitous variation of the sentence that I gave. A five or four meant that the sentence was ungrammatical or unacceptable. It was also helpful that, when my primary consultant would rate a sentence as a six, he would often be able to tell me what changes were required to make a sentence a seven, or fully grammatical. Sometimes these changes would simply be correcting agreement, or that he felt that there was a better vocabulary item in place of one which I had used somewhere in the sentence. Other times, the changes were related to what I was testing for and gave further confirmation that, in order for the sentence to be grammatical or acceptable, it would have to be reworded or restructured in some way.

8.3.4 Clear delineation of tasks

When working in a language which is not your own, it is important to learn how the language works in general, and then to test variations of the particular construction that you are looking at. In order to do both of these things, your consultant often has to play two different roles. The first role is that of teacher; there will be times when you will be asking the consultant to translate sentences into the target language or to correct the sentences which the field worker has constructed in order to make them grammatical. The second role that the consultant will have to play is the role of giving judgments, determining whether a sentence is grammatical or not, or whether a sentence is felicitous in a given situation. While these roles are very similar, it is important to distinguish them, otherwise it can be very frustrating for the consultants when they do not know what it is that's expected from them.

It can be very tempting to develop test sentences, including translating them and making sure that they are good Marwari sentences, and test the variations of the sentences at the same time. A better way to do this is to separate the activity of developing test sentences and the activity of checking sentences for grammaticality. In one activity, the research and the consultants are working together to develop good base Marwari sentences which will later be manipulated in order to test different constructions in different word orders. This will involve working together to make sure that the sentence has the

proper agreement patterns, proper Marwari vocabulary, and is grammatically correct.

In a second activity, the researcher will present a sentence which the consultant will judge as grammatical or ungrammatical. Because the basis sentence has already been checked with the right vocabulary and agreement marking, the acceptability of the sentence should only depend on the syntactic structure or word order.

One reason that it is helpful for the consultant to know when one activity has ended and another has begun is that as researchers, we are often interested in negative data. If the consultant thinks that you want them to continue correcting your sentences or to teach you good Marwari, they may become discouraged that you continue to make so many mistakes (Macaulay 2012). Also, when a consultant has been correcting translations or newly constructed sentences, they will often also offer corrections when the researcher is looking for grammaticality judgments. This makes it difficult to know if a sentence is ungrammatical as it is, or if it really is unacceptable without being changed and the consultant is just suggesting another way to write it.

It does not really matter what the activity of checking grammaticality judgments is called, or that it even have a name. What matters is that the researcher signals to the consultant(s) what is expected of them in a particular activity. There does not even need to be a large amount of time between the two activities, as long as the transition between them is clear. In my fieldwork, I found that a short tea break and a quick introduction to what were doing next was enough to signal that we were starting a new activity. Having a short break in between also gave me time to make any changes based on what had been elicited during the previous activity, or to write out the sentences that I wanted to test. Having a break in between also made the session less tedious for the Marwari speakers.

In order to signal that we are transitioning to grammaticality testing, I would simply tell the speakers that, ‘I have in front of me a list of sentences, and I want to check whether these are good Marwari sentences or bad Marwari sentences. I want you to tell me for each sentence whether this sentence is how you speak Marwari, or if this sentence is not how you speak Marwari.’ Alternatively, presenting the number scale was a very good way to signal that I was now looking for judgments. I would then explain, ‘I want you to rate each sentence on a scale of 1 to 7 (placing the written scale in front of them),

where seven means that this is very good Marwari and one means that this sentence does not mean anything at all’.

While this is a very simple transition, and the grammaticality testing does not require much introduction, is a very simple way to make expectations clear for whatever activity we were doing so that the process of elicitation and grammaticality testing went much more smoothly.

8.3.5 When all else fails

Regardless of how well constructed your questions are and how well you have trained your consultants, there will still be people who are simply not good at giving grammaticality judgments. There are several factors which come into play in giving grammaticality judgments besides familiarity with the language, including cultural considerations. In India, one of these cultural factors is the necessity of showing respect to people in authority, where authority may be determined by age or by position. At times, this factor may come into play because of the perceived status of a researcher versus a consultant.³ One way which this respect will be to never disagree with an elder or tell them that they have done something wrong. A consultant may therefore say that every sentence is grammatical even when it is clearly not. One way to mitigate this effect is to explain to your consultants that, while you are the one doing the research, they are the experts and authorities on their own language.

How can a researcher be certain that the grammaticality judgments that they are being given are accurate? One thing which I found helpful was to include control sentences amongst the sentences which I was testing. Control sentences are subject sentences which are clearly grammatical or ungrammatical. If a consultant consistently says that a control sentence is ungrammatical, even after appropriate training and instruction, this is an indication that their response is not actually reflecting their grammaticality judgment but is related to other outside factors. Having a control sentence also gives the researcher a way to gauge a speaker’s capacity for giving judgments without having to rely on the researcher’s own intuition about when something is wrong.

In the end, some consultants will simply never be able to give accurate

3. This perceived status may not just be related to position or education. When working in a foreign culture, the researcher is often seen as a guest and someone who should therefore be shown respect. The age of the researcher versus the consultant may also come into play; a young consultant may be reluctant to tell an older researcher that a sentence they have constructed is wrong.

grammaticality judgments. This may be because of cultural factors, this may be because of an unwillingness to disagree with the field worker, or this may simply be an inability to think about their language in the way that is needed for making grammaticality judgments. This should not come as a surprise. Assessing whether the things that we say are grammatical or not is a very unnatural way of using language.

On the other hand, it is not always easy to find people willing to participate in fieldwork, and if someone is willing and able to help, I suggest finding another way in which they can be useful. During the course of my own fieldwork, for instance, one particular consultant was unwilling to tell me when a sentence was bad even after a good deal of training. When I tested several control sentences, he still said that they were all acceptable even when they clearly were not. Eventually, I had to decide that his judgments were not reliable. Even so, he was still able to help with translating sentences from Hindi. I often worked with two Marwari speakers at once, both for convenience and in order to be culturally appropriate. This particular consultant worked well with the other speakers and he was often able to act as a sounding board for the other consultants during sessions.

8.4 Testing binding effects and Condition C

In the initial stage of research, I wanted to check the binding facts with regard to relative clauses in Hindi and Marwari, including both correlatives and postnominal relative clauses. The goal was to confirm the binding effects in the two constructions as described by Dayal (1996) and to test whether the same pattern held for adverbial correlative clauses.

Dayal (1996) describes the binding patterns of relative clauses as the following. Postnominal relative clauses and extraposed relatives pattern together. A pronoun in the relative clause can coindex with a proper name which c-commands the modified NP or head noun. In (1a), the subject of the main clause *Anu* is able to corefer with a pronoun inside of the relative clause *ā̃zo us-ko rāvi di tʰi* ‘which Ravi gave to her’, where coreference is indicated by subscripts. A proper name in the relative clause, on the other hand cannot corefer with a pronoun higher than the head noun. If the subject of the main clause is a demonstrative, as in (1b), it is not able to corefer with the proper name *Anu* inside of an extraposed relative clause. The notation *i is used to

show that coreference is not possible.

- (1) a. *ənu_i ne vo kitab tumha-re lije b^hed̄ʒi hε*
 Anu ERG that book.F.SG you.OBL-for send.PFV.F.SG PRS.3.SG
 [_{RC} *d̄ʒo us_i-ko rəvi ne di t^{hi}*]
 which that.OBL-DAT Ravi ERG give.PFV.F.SG PST.F.SG
 `Anu sent that book for you which Ravi had given her.' (*from*
 Dayal 1996, p. 164) [HINDI]
- b. *us_i-ne vo kitab tumha-re lije b^hed̄ʒi hε*
 that.OBL-ERG that book.F.SG you.OBL-for send.PFV.F.SG PRS.3.SG
 [_{RC} *d̄ʒo ənu*_i ko rəvi ne di t^{hi}*]
 which Anu DAT Ravi ERG give.PFV.F.SG PST.F.SG
Intended: `She sent that book for you which Ravi had given Anu.'
 (*from* Dayal 1996, p. 164) [HINDI]

This is true for both the relative clause which immediately follows the noun as well as for the extraposed relative.

Dayal (1996) also presents data which shows that, in the correlative construction, a demonstrative inside of the correlative can corefer with a proper name in the matrix clause or vice versa. In (2a), for example, the demonstrative phrase *us-ko* 'to that', which is inside the correlative *d̄ʒo kitab us-ko rəvi di t^{hi}* 'which kitab Ravi gave to that', can corefer with the proper name *Anu* in the main clause. Conversely, in (2b), the proper name *Anu*, which is inside the correlative, corefers with the demonstrative phrase *us-ne* 'that.ERG' in the main clause.

- (2) a. [_{CorrelCP} *d̄ʒo kitab us_i-ko rəvi ne di*
 which book.F.SG that.OBL-DAT Ravi ERG give.PFV.F.SG
t^{hi}] *ənu_i ne vo kitab tumha-re lije*
 PST.F.SG Anu ERG that book.F.SG you.OBL-for
b^hed̄ʒi hε
 send.PFV.F.SG PRS.3.SG
 `Anu sent that book for you which Ravi had given her.' (*from*
 Dayal 1996, p. 164) [HINDI]

- b. [_{CorrelCP} $\widehat{d}\bar{z}o$ *kitab* *anu_i ko ravi ne di*
 which book.F.SG Anu DAT Ravi ERG give.PFV.F.SG
t^hi] *us_i-ne vo kitab tumha-re lije*
 PST.F.SG that.OBL-ERG that book.F.SG you.OBL-for
b^hed̄zi he
 send.PFV.F.SG PRS.3.SG

'Anu sent that book for you which Ravi had given her.' (*from*
 Dayal 1996, p. 164)

[HINDI]

The binding effects discussed by Dayal differ from the binding effects described by Bhatt (2003), who argues that the subject of the main clause can bind into a correlative associated with the object of the clause (see Chapter 2).

- (3) [$\widehat{d}\bar{z}o$ *lark_i sita_i ko pjar karti he*]_j
 which girl.F.SG Sita ACC love do.IMPV.F.SG PRS.3.SG
us_j-ne us_i-ko t^hukra dija
 that.OBL-ERG that.ERG-ACC rejection.M.SG give.PFV.M.SG

'[Which girl loves Sita_i]_j, she_i rejected her_j.' (*from* Bhatt 2003, p. 513)

[HINDI]

The construction in (3) is felicitous and has the reading (4).

- (4) Which girl loves Sita, that rejected Sita.

Or, roughly: The girl who loves Sita rejected Sita.

If Bhatt is correct in saying that the correlative is base-generated within the same constituent, then it is important to be certain what binding configurations are and are not available. Further, if adverbial correlatives are the same kind of constructions, then it is important to show that they display the same binding effects as nominal correlatives.

Unfortunately, testing binding effects is not as straightforward as one might expect. Rather than confirming Dayal's judgments regarding postnominal relative clauses, which should have been fairly predictable, in the first two tests my consultants' judgments were unclear and inconsistent both between consultants and within judgments from the same consultant. In Section 8.4.1, I discuss two testing methods which did not yield accurate or consistent results

and why this may be the case. In Section 8.4.2, I present a new method for testing binding effects, the *Plausible Dissent* method (inspired by Crain and Thornton 1998) and show that this method of testing will give clear and consistent results.

8.4.1 How not to test for binding effects

When attempting to test for binding effects, specifically in testing for Condition C violations, I ran into several problems. Before I developed what I call the plausible dissent test, I attempted two other kinds of tests which I outline here. In the first round of testing, I introduced the sentence to be tested and asked several questions about it to try to determine who the demonstrative could refer to. For instance, I introduced the Marwari postnominal relative construction (5), which was translated from Hindi. In Hindi, the proper name *Anu* should be able to corefer with the demonstrative *unə-ne* ‘that.ERG’ inside of the relative clause *d̥ʒiki unə-ne rəvi di tʰi* ‘which Ravi gave to him/her.’

- (5) *ənu_i ba kitab ta-re vaste meli hε [RC d̥ʒiki*
Anu that.F.SG book.F.SG you.OBL-for send.PFV.F.SG PRS.3.SG which
unə_{i,j}-ne rəvi di tʰi]
that.OBL-DAT Ravi give.PFV.F.SG PST.F.SG

‘Anu sent that book to you which Ravi had given her.’ [MARWARI]

After translating (1a) to (5), I asked my consultants several questions regarding the meaning of (5), including (6). They responded with (7).

- (6) Q: Who did Ravi give the book to?

- (7) A: Ravi gave the book to Anu. This can never mean that Ravi gave the book to Sita.

As expected, in answer to (6), both consultants said that *unə-ne* ‘that-ERG’ can refer to Anu. Surprisingly, though, they also said that *unə-ne* cannot refer to someone other than Anu, such as Sita. This is presumably because Sita is not mentioned in the situation described by the sentence; this that this approach is eliciting, not only judgments based on grammaticality, but also judgments according to a situation.

Sentences which were expected to result in a violation of Condition C resulted in even more mixed judgments. The subscripts here indicate the expected coindexing.

- (8) *bo_i ba kitab ta-re vaste meli he*
 that.M.SG that.F.SG book.F.SG you.OBL-for send.PFV.F.SG PRS.3.SG
 [_{RC} *d̪ʒɪki anu*_i nɛ rəvi di tʰi*]
 which.F.SG Anu DAT Ravi give.PFV.F.SG PST.F.SG
 ‘Anu_i sent that book to you which Ravi had given her*_i.’ [MARWARI]

Given the sentence (8), I asked the question (9) and received the responses in (10).

(9) Q: Who sent the book to you?

- (10) A1: Ravi.
 A2: It could be anyone.
 A3: It can be Anu.

All of the responses in (9) were from one consultant. Initially, he said that Ravi sent the book, then revised his response to ‘It could be anyone’. After further consideration, he said that it could be Anu, ‘because no other name is there’. Responses from other Marwari consultants were similar, and the same method of testing in Hindi had the same inconsistent results.

This approach failed because it was putting far too much of the weight of analysis on the consultant. When assessing sentences, speakers also considered the situation introduced by the sentence. In this case of (8), this was a situation which minimally includes Ravi, Anu, and the person who the book was sent to. If no one else was introduced into the situation, speakers assumed that the demonstrative must refer to either Ravi or Anu, even if the syntax did not allow it.

Based on these responses, there are two options. The first is to assume that Condition C does not apply in these varieties or that it is more flexible than it is in other languages. This would be unexpected, though, as Bhatt and Dayal both show that Condition C applies in at least some varieties of Hindi, and there is no reason to believe that it does not apply in the others. The second possibility is that the testing method is insufficient and some other method

of testing is necessary. Because consultants' responses were inconsistent and contradictory, I believe that the testing method was insufficient and another method is necessary. If this method of testing does not give predictable results for postnominal relative constructions whose binding effects are fairly certain, then it will not give reliable results for binding effects in correlative constructions, either. Another method of testing is required.

The second approach to testing binding effects involved more clearly defined situations using pictures. In this test, I presented the consultant a drawing involving two frames. In the first frame, Geeta was stirring a bowl and thinking of herself eating a cake. In the second frame, Geeta was eating the cake which she had made. We also discussed the picture briefly to confirm that it was indeed Geeta who, having made the cake for herself, ate the cake. I then presented the sentence (11) and asked, 'Is this true or false?'

- (11) *us_i-ne* *vo kek* [_{RC} *d̥ʒo gita_{ʔi} ne əpne lije*
 that.OBL-ERG that cake.M.SG which Geeta ERG own.self.OBL-for
 bənaja] *k^haja*
 make.PFV.M.SG eat.PFV.M.SG

'She ate that cake which Geeta made for herself.' [HINDI]

Responses varied greatly. My Hindi consultant said that (11) is true in a situation where Geeta made the cake, which is not expected. Given the same sentence in Marwari (12), two Marwari consultants initially said that (12) is false in a situation where Geeta ate the cake which Geeta made for herself, but then they both changed their response to true, meaning that *gita* and *ba* 'that.F.SG' can corefer.

- (12) *ba_i* *bo kek* [_{RC} *d̥ʒəko gita_{ʔi} əpre vaste*
 that.F.SG that.M.SG cake.M.SG which_{RC} Geeta own.self-for
 bənajo] *k^hajo*
 make.PFV.M.SG eat.PFV.M.SG

'That ate the cake which Geeta made for herself.' [MARWARI]

Other situations were tested, as well, and responses to picture tests were consistently inconclusive. Sentences which did not involve a violation of Condition C gave predictable results, but responses to sentences which were predicted to lead to a violation of Condition C elicited ambiguous responses. In

some cases, a consultant would look at previous sentences and decide, based on the names there, whether the demonstrative could refer to a particular person. In other cases, a consultant would either give contradictory responses over several sentences involving the same type of construction or different responses for the same sentence on rechecking.

These tests highlight the importance of using good methodology and of being clear about what methods are used. Tests involving elicited response or true-false tests based on simple situations are not reliable for several reasons. First, it was difficult to get clear, accurate judgments. Judgments between speakers varied, and often even the same speaker would give conflicting judgments at different points in time. Second, when there was a predicted violation of Condition C, even though consultants eventually said that the sentence was acceptable, there were obvious clear, long pauses before responding. If I was working with multiple consultants, they would often pause to discuss these examples.

In order to test binding effects across constructions, it was important to develop a test which was consistent and with clear judgments. To do so, the test must not require consultants to do the linguistic analysis themselves. In the next section, I will discuss just such a test – the ‘plausible dissent’ method – which results in clear, consistent judgments across speakers even when testing several different types of constructions.

8.4.2 Testing binding effects: ‘Plausible Dissent’

There are two problems with a direct testing method of binding effects. The first is that experimental data shows that participants will often reanalyze the syntax of a sentence in order to come to a semantically felicitous interpretation, particularly with regard to more difficult to process constructions such as passives and relative clauses. Second, when testing felicity in binding effects, participants look for an appropriate reference within the relevant context. If no appropriate referent is available, participants will interpret the demonstrative as referring to whatever referent is available, even if this leads to a violation of Binding Conditions. This will lead to inconsistent, delayed responses from informants and an apparent violation of Binding Condition C.

In order to develop a test which will elicit clear, consistent responses with regard to binding, it is important to understand why the previous testing

methods did not work.

Experimental research has shown that there are some constructions which are more difficult to process than others. For instance, the object-relative has been shown to be more difficult to process than the subject-relative (Wanner and Maratsos 1978). In a subject-relative such as *that irritated the banker* (13), the relative gap is the subject of the postnominal relative clause.

- (13) The lawyer that irritated the banker filed a hefty lawsuit. (*from* Traxler et al. 2002, p. 69)

In an object relative, the relative gap is the object of the postnominal relative clause. In a sense, the head noun of the relativized NP acts as the object of the relative clause. For example, in (14), the lawyer is the object or theme of the event of irritating.

- (14) The lawyer that the banker irritated filed a hefty lawsuit.

Traxler et al. (2002) propose that the difficulty in processing an object-relative comes from a combination of syntactic analysis and semantic plausibility. They compare the contrast in processing subject- and object-relatives to the contrast in processing active and passive sentences. Christianson et al. (2001) and Ferreira and Henderson (1998) show that the ability of participants to assign unexpected theta (θ) roles to concepts introduced in a sentence is inversely related to the syntactic complexity of the construction being investigated. That is, nouns can more easily take unexpected θ -roles in simple, active sentences, but respondents tend to revert back to expected θ -roles in passive constructions, choosing an interpretation which violates the grammar. To illustrate, consider the sentences in (15) and (16). In both sentences, the cheese is the agent and the mouse is the patient.

- (15) The cheese ate the mouse.

- (16) The mouse was eaten by the cheese.

While the θ -roles in both sentences are unexpected, participants were much more likely to interpret (16) as the mouse eating the cheese. That is, participants will reanalyze the syntax in order to get a semantically felicitous interpretation. Mapping becomes more difficult and error-prone as the syntax becomes more complex.

Traxler et al. (2002) argue that respondents show the same kind of processing difficulties in interpreting relative clauses. Respondents have the greatest difficulty processing object-relative clauses. Traxler et al. (2002, p. 84-85) conclude that respondents ‘considered an ungrammatical alternative when the grammatical construction failed to produce an acceptable semantic result’. The data suggests that not only will people entertain syntactic alternatives when the ‘syntactic cues fail to discriminate between different possibilities,’ but they will also entertain ‘a simpler syntactic structure when word order information points them to a more complex alternative’.

In Hindi and Marwari, most constructions which retain the necessary binding effects will be harder to process. Postnominal relative clauses, for instance, must relate to something below the subject of the main clause, such as the object, in order for a subject to potentially bind into them. While Traxler *et al* do not discuss correlatives, I predict the processing to correlative to be similar to the processing of postnominal relative clauses. Further, I suggest that constructions which violate Condition C are analogous to applying an unexpected θ -role. One piece of evidence for this is the difference between consultants’ responses to sentences which did not involve a violation of Condition C versus sentences which did. While responses were not formally timed, there was an obvious delay in the amount of time it took consultants to respond to sentences which involved a violation of Condition C. I hypothesize that this delayed response, the hesitancy in giving judgments, and the fact that consultants ultimately decided that these sentences are acceptable reflects the same difficulty in processing and results in a willingness to reanalyze the syntax in order to produce an acceptable semantic result.

The unexpectedness of the θ -role relates to the consultants’ hesitation in allowing the demonstrative to refer to anyone who was not explicitly present in the situation. If consultants are only considering the minimal situation introduced by the target sentence, then the demonstrative can only refer participants introduced by that sentence. The difficulty in processing comes from the conflict between the lack of participants for the demonstrative to refer to, a pragmatic restraint, and the syntactic restraint on which participant the demonstrative may take as its referent. In order to resolve this conflict, respondents are willing to consider a grammatical alternative when the syntax failed to produce an acceptable result. It is possible to develop a testing methodology which avoids this conflict. Because the syntactic restriction is

what is being tested, the demonstrative must be allowed to refer to someone other than the person whose name it c-commands.

Crain and Thornton (1998) point out that there is an important distinction between falsity and infelicity. Infelicity comes from the violation of a pragmatic constraint, or the conditions in which the sentence is used in ordinary discourse. That is, sentences must be relevant to the discourse in which they appear. In language acquisition tests, when a child is asked to judge a sentence which is not relevant to the discourse, they must choose between violating a pragmatic constraint or a syntactic constraint – in this case, Principle C. I posit that the same principle holds for adult speakers, as well. In the tests described in Section 8.4.1, example (5), for instance, Sita is not a relevant part of the discourse so the package could not have been given to her. In order for the sentence to be felicitous, the respondent will then reanalyze the sentence so that it is semantically acceptable even when the syntax dictates otherwise (Traxler et al. 2002).

When developing a truth-value judgment test, it is important for the respondent to know why their answer is true or false (Crain and Thornton 1998). If it is not clear why it is false (i.e., it was someone else who ate the cake), then consultants may and will say that it is true. Understanding that the sentence is false because the demonstrative cannot refer to Geeta, even though she is the only one present in the situation, requires the consultant to recognize that the sentence is both ungrammatical and violates a pragmatic constraint. In order to avoid this, it is important to provide a pragmatically feasible interpretation which can then be judged as true or false. Crain and Thornton (1998) call the availability of this interpretation the *condition of plausible dissent*.

I propose a new method for testing binding effects, the *plausible dissent* method, which makes available an alternative, pragmatically feasible interpretation.⁴ This method avoids the conflict between the pragmatic restraint and the syntactic restraint, allowing respondents to assess the target sentence without employing syntactic reanalysis. Once the correct testing method was employed, I found that consultants responses were consistent and without the hesitation seen in previous testing methods.

The essential component of the plausible dissent method is that there is a second, plausible character within the situation who the demonstrative may refer to. The easiest way to achieve this is to have a story with two characters

4. With thanks to Paul Elbourne for suggesting this approach.

than testing these sentences on their own, though, I presented them as true/false statements following a simple 6-10 sentence story, as described. I also testing other true-false statements about the content. This not only obscured what exactly it was that I was testing for but also ensured that some of the test sentences were true.

After translating the story, I then asked one of the Marwari speakers to read the story aloud to two other speakers. He read them the instructions and, after reading the story, presented each of the test sentences while I wrote the responses. Having a Marwari speaker read the story was advantageous for several reasons. First, in reading the story aloud, he was able to correct some of the small errors we had missed in translating each sentence. These errors were usually with regard to agreement, while some, such as adding an emphatic marker where appropriate, were to make the story more natural. The second advantage to this was that I was able to record the story so that it can be used for further testing with other speakers, even when there is no one available to read it aloud. Finally, because I am not a native speaker, my pronunciation and intonation is not natural and acts as a distraction to the respondents.

Responses to sentences tested this way were consistent when rechecked with the same speaker. Consultants responded much more quickly, with more consistent responses between speakers,⁵ and with more confidence in their responses. Unlike previous testing methods, even when more than one consultant was participating, they no longer felt the need to discuss their responses before giving an answer.

Having established that the plausible dissent method gives reliable, accurate results for postnominal relative clauses, I used the same method to test

5. Of seven stories, each testing at least one target sentence and including on average two control test sentences, only one truth-value judgment received mixed responses. One speaker said that (i) was true while three other respondents said that (i) is false. It is possible that this was rejected because it was being interpreted as a free relative construction, which most speakers do not allow.

(i) [Both Bhomlii and Jyoti put their flowers where they can see them]:
ba apra p^hul melija d̥ʒəi^he b^homli uṇa ne
 that.f.sg own.M.PL flower.M.PL put.PFV.M.PL where Bhomli those.OBL.M.PL ACC
har d̥m dek^h səke
 each day see able.SUBJ.3

'She put her flowers where Bhomlii was able to see them.' [MARWARI]

Binding effects in temporal correlative clauses were tested in another story, as well, and all of the respondents' judgments were consistent.

binding effects involving Condition C for both nominal and adverbial correlative constructions. For examples of some of the stories which were tested and a summary of consultants' responses, see Appendix B.

While I chose to present the situations in Marwari, Bochnak and Matthewson (2015) suggest that the situation does not necessarily have to be set up in the target language. I found it helpful to translate the entire story into Marwari, though, rather than giving the story in Hindi. First, because I am not fluent in Hindi, this would have required checking the story with a native speaker before testing. This was not always an option, and it was usually easier to translate the story into Marwari and check it at the same time. Second, translating the story allowed me to use slightly modified versions of the sentences in the story as the test sentences without giving away what I was testing for. Modifications, in this case, were usually switching the demonstrative and proper name or extraposing a relative clause.

This method of testing also allows binding tests to be incorporated into longer stories or story arcs which can then include truth-value judgment tasks.

8.5 Testing for presuppositions

Is it possible to show that a sentence includes a presupposition without relying on a native speaker's ability to analyze a construction? It would not be good elicitation technique to ask a speaker whether a sentence A takes a proposition B 'for granted' as this would be asking the consultant to do linguistic analysis (Matthewson 2006).

Often, the way that semanticists test presuppositions is through the Presupposition Test. Put simply, a presupposition holds even under negation. Given two sentences A and B, if both A and not A entail B, then A presupposes B. Matthewson (2006) argues, though, that the fact that presuppositions project through certain operators, including negation, is unable to clearly show that one statement presupposes another without asking whether that statement is taken for granted.

Another difficulty when applying negation to correlatives, which have two clauses, is the possibility that both clauses make an assertion, and negation of the second clause does not negate the assertion of the first clause. To see this, consider the correlative constructions in (17a) and (17b).

- (17) a. *mə-ne* [*d̪ʒəka* *tʃʰora* *heŋ laɖu* *kʰaja*]
 I.OBL-DAT which.M.PL boy.PL all laddu.M.SG eat.PFV.M.SG
be *həkra* *lage*
 that.M.PL good.M.PL attach.IMPV.PRS.3.PL
 'I like the boys who ate all of the laddus.'
Lit.: 'I like, which boys ate all the laddus, those.' [MARWARI]
- b. *mə- ne* [*d̪ʒəka* *tʃʰora* *heŋ laɖu* *kʰaja*]
 I.OBL ERG which.M.PL boy.M.PL all laddu.M.SG eat.PFV.M.SG
be *həkra* *koni? lage*
 that.M.PL good.M.PL NEG attach.IMPV.PRS.3.PL
 'I do not like the boys who ate all of the laddus.'
Lit.: 'I do not like, which boys ate all the laddus, those.' [MARWARI]

Both (17a) and (17b), where (17b) is the negation of (17a), are true only in situations where there is a boy who ate all of the laddus. This is not sufficient evidence, though, to show that the correlative carries a presupposition. It is possible that the correlative *d̪ʒəka tʃʰora heŋ laɖu kʰaja* 'which boys ate all the laddus' simply asserts there are some boys who ate all the laddus. (17b) would then have the interpretation in (18).

(18) There are some boys who ate all the laddus, and I do not like them.

In this case, (17a) and (17b) are still true only in situations where there are boys who ate all of the laddus, but this does not have to be part of the background information or taken for granted by the participants.

It actually is the case that correlatives carry a presupposition of uniqueness, but more sophisticated testing methods will be necessary in order to show that such a presupposition exists.

Matthewson (2006) offers a method for testing for presuppositions which she calls the *Pragmatic Presupposition Approach*. When faced with a presupposition which is not part of the background and which cannot be easily accommodated, a listener will often challenge the presupposition itself with a wait-a-minute response. This type of test has also been called the 'Hey, wait a minute' test (von Stechow 2001). For example, if a speaker were to make the statement in (19a) in a context where Mark has never called before, a listener may with respond with (19b).

- (19) a. Mark phoned again.
b. Again! I didn't know that he'd phoned in the first place.

Matthewson suggests several different ways to elicit a 'wait-a-minute' type response from a participant:

- (20) Methods suggested by Matthewson for testing wait-a-minute responses:
- (a) Intentionally causing presupposition failure in real-life discourse situations.
 - (b) Asking a consultant to translate English discourses containing wait-a-minute responses.
 - (c) Attempting to construct wait-a-minute responses and asking consultants to judge discourses containing them.
 - (d) Explicitly discussing the test, using the common language to illustrate, and asking for similar responses in the target language.

Other factors to consider when setting up a wait-a-minute test are how easily a presupposition can be accommodated, and the closeness of the relationship between the speaker and addressee (Matthewson 2006). If a presupposition is easily accommodated, it may be accepted as part of the discourse without being challenged by the hearer and therefore not elicit a wait-a-minute response. The relationship between the speaker and addressee can also affect what presuppositions are already part of the background information or which will be easily accepted. For instance, Matthewson points out that, if someone were to say that they are on their way to meet their fiancée, responses will vary depending on how well the hearer knows the speaker. A relative stranger may easily accept the presupposition that a speaker has a fiancée whereas someone who knows the speaker is not in a relationship will be less likely to accept the presupposition.

Another consideration when setting up these tests which I found relevant in my own research was the proficiency of the researcher in the target language. For instance, because my Marwari is minimal, it really was not feasible for me to intentionally introduce a presupposition failure into the discourse.

I used several different methods to show that correlatives in Marwari carry a presupposition. The first method was the *obscured picture* test. This method

allowed me to introduce a presupposition failure in a specific, controlled discourse context. In this test, I showed two to three consultants a picture in which some detail was obscured. I then gave the consultants a correlative construction which was already checked for grammaticality and then asked them whether the statement was true or false. What was important in this methodology was not whether a respondent says a sentence is true or false, but the discussion afterward of *why* they responded in that way. For this reason, it was helpful to show the picture to two to three people at one time so that they could discuss why they felt like a statement was true or not.

In the first test, consultants were shown a drawing of a family scared of a sound coming from a bush and asked whether the following statement is *hātī ja d̄ʒʰut* ‘truth or falsehood.’

- (21) [*d̄ʒəko* *fer* *d̄ʒʰadija* *mē he*] *har ek*
 which.M.SG tiger.M.SG bush.OBL in be.PRS.3.SG each one
 mʰanko un:-ū *dəre*
 person that.OBL-from be.scared.PFV.M.PL

‘Every one of them was scared of the tiger in the bush.’

Lit.: ‘Which tiger is in the bushes, every person is scared of that.’

[MARWARI]

Whether (21) is acceptable or not depends on the respondent’s willingness to accept the presupposition that it is a tiger which is making the noise. One respondent said that this was clearly true because, ‘Everyone knows that that kind of voice coming from a bush is a tiger’. Others argued that it must be false because, ‘How can we know that it is a tiger? It could be something else’. Both responses indicate that there is a presupposition here which may or may not be taken for granted.⁶

Marwari speakers were also shown a picture of three girls standing at a bus stop, where one of them is holding an umbrella. They were then asked whether (22) is true or false.

6. In retrospect, this was a case of the researcher not taking cultural background information into consideration when presenting a presupposition. There are many stories and folk tales in India which involve a tiger hiding in the bushes, leading to an easily accommodated presupposition which, as Matthewson (2006) points out, is something which should be avoided. Fortunately, in this case it was clear in the discussion between the informants that the acceptability of the sentence depended on how willing the respondent was to accept that it was a tiger which was making the noise.

- (22) [*d̄ʒiki* *t̄ʃori* *hosijar he*] *un-ne kane*
 which.F.SG girl.F.SG smart be.PRS.3.SG that.OBL-near
 satri *he*
 umbrella.F.SG be.PRS.3.SG

'The smart girl has an umbrella.'

Lit.: 'Which girl is smart, she has an umbrella.' [MARWARI]

Again, the responses to (22) varied depending on the respondent's willingness to accept the presupposition that the girl is intelligent. One speaker said that it was true because, 'She is the only one [in the picture] prepared for rain'. The other said that it is clearly false because 'maybe she is just crazy', and that is why she is carrying an umbrella. These responses show that (22) presupposes that there is a girl who is smart.

It is also possible to incorporate several of the presupposition tests into a single story. In order to do this, I wrote a simple story in English and, together, the Marwari consultants and I translated each sentence to Marwari. Having translated each of the sentences separately, I asked the consultants to help me put them all together to make a Marwari story that was natural and how a Marwari speaker would have written it. This allowed me to use several of Matthew's methods for checking for presuppositions, including the tests 20b and 20c, as well as another method introduced in (von Fintel and Matthewson 2008) which I call the 'Can I start a story this way?' test.⁷

After translations all of the sentences in the story, I returned to the first few sentences, in (23), and asked the Marwari speakers, 'Can I start a story this way?'

7. That stories in Hindi do not seem to start with a correlative construction is at least an indication that the correlative carries a presupposition. I looked at approximately 50 written stories in Hindi, and none of them began with a correlative construction. This hints that the correlative has a definite interpretation and cannot be used when it is not part of the background knowledge. This is not sufficient evidence to show that they definitely carry a presupposition, though. Correlatives are a relatively rare construction in Hindi; looking at several hundred stories would not be a sufficient sample size for determining that a story cannot start with a correlative construction. There are even fewer stories written in Marwari, and these are seldom written in the less prestigious varieties. This is a case, then, where evidence must include negative data and working with a consultant.

(23) a. *ek dm ek i^hoto gaō ho d̄z̄m:ō*
 One day one small.M.SG village.M.SG be.PST.3.sg which.OBL-POSS
nam sangāria ho
 name Sangaria be.PRES.3.SG

'One day, there was a small village which was called Sangaria.'

[MARWARI]

b. [*d̄z̄iko minək sareṭṣā ũ aijo ho*]
 which man.M.SG Sarechan from come.PFV.M.SG PAST.M.SG
vo apre pāriṅar re hat^he pa|a-pa|a
 that.M.SG own family.OBL.M.SG with on.foot-REDUP
d̄z̄aiṭo
 go.IMPV.M.SG

'The man from Sarechan was walking along with his family.'

Lit.: 'Which man came from Sarechan, he was going on foot with his family.'

[MARWARI]

The Marwari consultants said that this is not a good way to start a story and suggested that I change the correlative clause *d̄z̄iko minək sareṭṣā ũ aijo ho* 'which man came from Sarechan' in (23b) to the sentence in (24), where the *wh_{RC}* has been changed to an indefinite pronoun. The main clause is then a separate sentence.

(24) *ek minək sareṭṣā ũ aijo ho*
 one man.M.SG Sarechan from come.PFV.M.SG PAST.M.SG

'A man from Sarechan came along.'

[MARWARI]

Method (20c) involves constructing wait-a-minute responses as part of a discourse and to asking consultants to judge their grammaticality. As part of the same story, I included a correlative whose content was not established in the context. Another character (in this case, the speaker's sister) challenges the presupposition. In this situation, the family of two parents and a brother and sister is considering a noise coming from the bushes. The boy points to the bush and says (25a), and his sister responds with (25b).

- (25) a. *tʰoro kaijo* [*ḍʒəko fer babulija mē*
 boy.M.SG say.PFV.M.SG which tiger.M.SG bushes.OBL.M in
hε] *vo heṅə-ne kʰaʒi ḍʒaʒi*
 be.PRS.3.SG that.M.SG all-ACC eat light.FUT.F.SG

‘The boy said: The tiger in the bushes will eat us all!’

Lit.: ‘The boy said: Which tiger is in the bush, that will eat us all!’

[MARWARI]

- b. *tu kɪkar ḍʒaṅe hε ke vo*
 you how_? know.IMPFV be.PRS.3.SG COMP that.M.SG
ek fer hε
 one tiger.M.SG be.PRS.3.SG

‘How do you know that that is a tiger?’

ho səke ke vo bandro hε
 be able.IMPFV COMP that.M.SG monkey.M.SG be.PRS.3.SG

‘It’s possible that it is a monkey.’

[MARWARI]

All of my consultants agreed that (25b) is a felicitous continuation of (25a). Unfortunately, Hindi and Marwari do not have an exclamation which means the same thing as, ‘Wait a minute!’ It is therefore possible to analyze the correlative *ḍʒəko fer babulija mē hε* ‘which tiger is in the bushes’ as an assertion that there is a tiger in the bushes and not necessarily as a presupposition.

Taken individually, these tests indicate that correlatives carry a presupposition, some more strongly than others. Together, the fact that all three methods indicate that the correlative can evoke a wait-a-minute response is strong evidence that a correlative includes a presupposition which may be challenged.

8.6 Conclusion

In this chapter, I have related just some of my experiences and the techniques that I used when conducting fieldwork in Hindi and Marwari. Some of these techniques were suggested by other sources, while some of them were the result of repeated trial and error.

Fieldwork is never as neat or easy as it appears in textbooks, and it is

often impossible to know the story behind the example sentences presented in so many linguistic papers. It is important, whether the researcher is working in their own language or is working in an unfamiliar language, that we document our methodology and share our experiences with other researchers. This not only lets the reader know that the methodologies used are sound, but will also help other researchers avoid making the same mistakes, allowing them to gather better data or develop even better methods.

In some cases, the methodology that I used was based on the experience and expertise of other researchers. In others, the methods were more a result of learning by doing – where ‘doing’ meant more trial and error than actually doing. No matter how many times I had been advised to never, ever ask a consultant what a sentence means, it took asking the question several times to convince myself that it was never going to achieve helpful results. Similar questions one should never ask, but always do, include ‘What’s the difference between these two sentences?’ and ‘When can I say this?’ These questions, while they seem like natural things to ask, expect the consultant to have thought about their language in a way which most people have not. While the language speaker is the expert in their own language, it is our job as the researcher to do the actual analysis.

Often, we ask these questions because we do not have the necessary tools to delve into a language and determine what a phrase means for ourselves. While syntactic methods and grammaticality tests have their place, different methods are necessary for getting at the meaning of a sentence. Just as we are all able to use language fluidly and proficiently, abiding by a list of innate grammatical rules which we do not actually understand nor can we explain, we are able to communicate fluently and effectively without thinking about the meaning of the individual words or how they are composed. In the same way that syntacticians have to manipulate language in order to reveal the grammatical rules it is structured on, semanticists cannot just attack phrases head-on with open-ended questions but have to play with and bend language in order to uncover the meaning hidden in the words that people use every day.

Chapter 9

Implications and conclusions

9.1 Introduction

Throughout this dissertation, I have focussed primarily on the relationship between the correlative clause and the demonstrative correlate in the main clause. In Chapters 3 and 5, I argued that the correlative is, in fact, an overt realization of the index of the demonstrative and enters the syntax as an argument of the demonstrative phrase. Further, I showed in Chapter 4 that the single headed correlative has the same semantic contribution as a definite description.

If it is true that the correlative is the index of the demonstrative, and that the correlative denotes an individual rather than a relation or set of properties as Dayal (1996) suggests, then it stands to reason that other DPs and definite descriptions should be able to enter the syntax as the index of a demonstrative, as well. This proves to be the case.

This chapter looks at several other cases of the index of a demonstrative being spelled out overtly cross-linguistically. I present new data which demonstrates that this is possible not only in MIA languages but also in languages which do not have a typical correlative construction. In Section 9.2, I will show that there are other DPs in MIA, including Hindi, Marwari, and Palula, which are able to act as overtly realized indices. These include demonstrative phrase where the NP is modified by a restrictive relative clause, quantifier phrases, and, in Marwari, proper names.

Section 9.3 looks at languages which do not have a correlative construction, *per se*, but do allow the index to be overtly pronounced. One example of this is sign language. Lillo-Martin and Klima (1990) and Sandler and Lillo-Martin

(2006) have argued that pronouns in sign language include an overtly realized referential index (Section 9.3.1). This index, the locus of the pronoun, may either be a location in space which is assigned to a noun phrase or a locus which is assigned to some entity such as a location, which is then related to the referent of the pronoun.

Another language with overtly realized indices is Mandarin Chinese (Section 9.3.2). In Mandarin, demonstrative phrases, proper names, and prenominal relative clauses may act as overtly realized indices (Section 9.3.2).

Finally, in Section 9.4, I return to Marwari to look at why certain types of prenominal relative clauses cannot act as the index of a demonstrative. Only those prenominal relative clauses which always have a definite interpretation may be selected as the argument of a demonstrative.

In Section 9.5, I briefly discuss some of the restrictions on what elements may act as an overtly realized index and what direction future research might take.

9.2 Other MIA correlative-type constructions

If it is possible for an index to be overtly pronounced, there should be other cases of this beyond the correlative construction. Examples of this can be found in MIA languages, including Marwari and Hindi. There are several types of DPs which can take the position of the correlative clause and which relate to the main clause through a demonstrative correlate.

Nearly all of these examples were offered by consultants during fieldwork, often as an alternative to a correlative clause construction which I was trying to elicit but which was ungrammatical or which was an overly complex way of saying something which could have been put more elegantly. A few examples come from natural speech, as well, as heard in conversation or said during general discussion during Hindi language learning sessions.

In (1), a DemP whose NP component is modified by a postnominal relative clause relates to the main clause through another demonstrative phrase.

- (1) [DemP *vo* [NP *larkī* [RC *ḍāḍo mudḍ^he pāsənd hē*]]
 that girl.F.SG which_{RC} I-DAT liking be.PRES.3.SG
vo] *aegi*
 that come.FUT.F.SG

'The girl who I like will come.'

Lit.: 'That girl who I like, that will come.' [HINDI]

While (1) looks quite similar to the correlative, it is not the same construction. The *wh_{RC}* here is not the relativizing *wh* found in the correlative but is a relative pronoun *wh_{RC}* heading a restriction relative clause. The relative clause modifies the NP *larkī* 'girl'.

A similar example is (2), below. In this example, the DemP *je kitab ḍāḍo rāvi ke pas rāk^hi hē* 'this book which Ravi kept' is associated with the main clause through another DemP *vo kitab* 'that book'.¹

- (2) [DemP [DemP *je* [*kitab* [RC *ḍāḍo rāvi ke pas rāk^hi*
 this book.F which Ravi near keep.PFV.F.SG
hē]] *vo kitab*]_i *ānu ne ṭi di*
 PRES.3.SG that book.F.SG Anu ERG give.PFV.F.SG

'Anu gave (him) the book which Ravi kept.'

Lit.: 'This book which Ravi kept, Anu gave that book (to him).' [HINDI]

In this case, the word order is ambiguous between a postnominal relative and an appositive, but based on the context it is a postnominal relative. (2) involves a demonstrative phrase which is acting as an overtly pronounced index of a second DemP. In (2), the entire DemP-DemP constituent *je kitab ḍāḍo rāvi ke pas rāk^hi hē, vo kitab* 'this book which Ravi kept, that book', which is the object of the main clause, has been fronted to mark topicality.

Like the correlative construction, the demonstrative *vo* is able to take an overtly realized phrase as one of its arguments. In the case of the correlative construction, this was the correlative clause. In (2), the index of the demonstrative is another demonstrative phrase. The demonstrative phrase *je ḍāḍo*

1. It is not clear why the matrix DemP is headed by the distal demonstrative *vo* 'that' and the embedded DemP is headed by the proximal demonstrative *je* 'this.' This particular sentence did not come from spontaneous speech, but was offered by my primary Hindi consultant as an alternative to a sentence which he considered less felicitous. The choice of demonstratives was his, and is probably somehow related to the personal context.

rəvi ke pas rəkʰi he vo kitab ‘this book which Ravi kept, that’ has the structure (3).

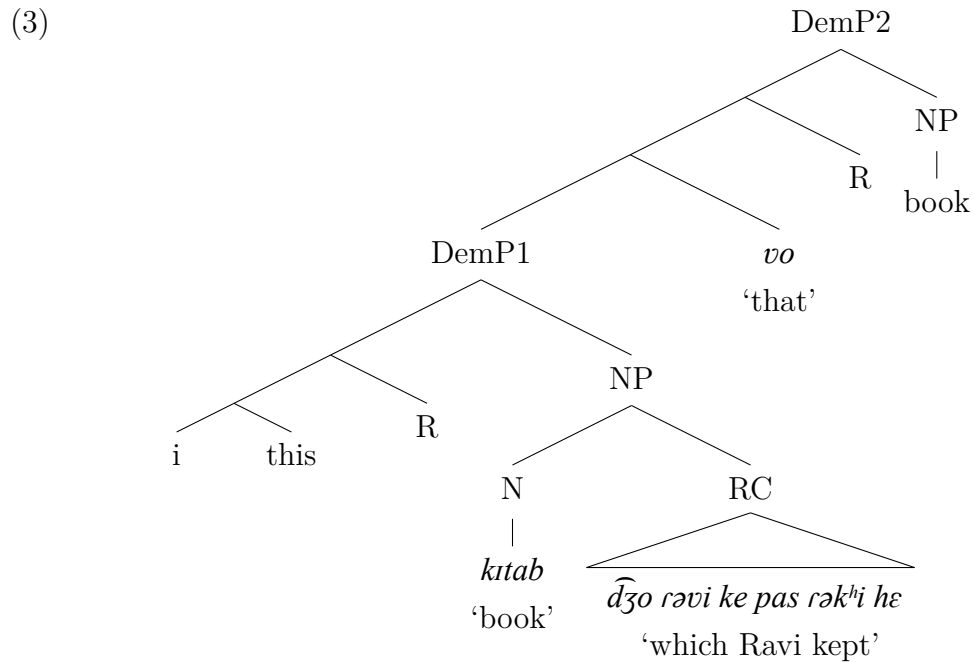

It is also possible for a DemP modified by an appositive to act as an overt index. (4) is from Palula, a MIA language spoken in Pakistan. Liljegren (2008, p. 355) notes that *so yambaát ga ghini bíi de* ‘who used to walk with the millstone’ is a non-restrictive relative clause (i.e., an appositive, AppP) modifying *so giđúuču paalawaán* ‘the strong man of Damel’.

- (4) [DemP [DP *so giđúuču paalawaán* [AppP *so yambaát ga*
 he.M.SG Dameli.man strong.man he mill.stone PART
ghin-í b-íi de]] *eesó*] *na şandil-u*
 take-CV go-3.SG PST that.M.SG NEG take.up.challenge-PFV.M.SG
maní
 HEARSAY

‘The strong man of Damel, who used to walk with the millstone, that (man) apparently did not take up the challenge.’ (from Liljegren 2008, p. 355)

[PALULA]

Liljegren assumes that the embedded clause *so yambaát ga ghini bíi de* ‘who used to walk with the millstone’ is acting both as a modifier of the DemP and as a correlative clause whose correlate is the DemP *eesó* ‘that’ in the main

clause. I suggest that this is actually a case of a DemP-appositive constituent (or a demonstrative phrase modified by an appositive) entering the syntax as the index of the demonstrative *eesó* ‘that’.

It is not only demonstrative phrases which can enter the syntax in this fashion. The sentence in (5a) shows that a quantifier phrase such as *har ek t̃ʰor* ‘each thief’ can also act as an argument of the demonstrative. As (b) shows, the same construction in Hindi is possible, as well.

- (5) a. [DP *har ek t̃ʰor*]_i *tʰe bud̃ʒijo ke kaji t̃i be d̃ʒel*
 each thief you.HON ask.PFV.2.M COMP WH_Q those jail
gija he
 go.PFV.M.SG PRES.3.SG

‘You asked whether each and every thief has gone to jail.’

Lit.: ‘Each thief, you asked if (did) those go to jail.’ [MARWARI]

- b. [DP *har ek t̃ʰor*]_i *ap-ne put̃ʃa ki*
 each one thief you.HON-ERG ask.IMPFCT.2.PL COMP
*kya t̃i *(vo) d̃ʒel gaja he*
 WH_Q that jail go.PFV.M.SG PRES.3.SG

‘You asked whether each and every thief has gone to jail.’ [HINDI]

In reference to (b), my Hindi consultant pointed out that the demonstrative *vo* is not optional and the sentence is ungrammatical if it is removed.

There are other cases, though, where the matrix verb prevents the quantifier phrase from raising out of the complement clause. An example of this is (6a), which met with mixed judgments in Marwari. One Marwari speaker said that (6a) is marginally acceptable, but (5a) is much better. Another Marwari speaker said that (6a) is ungrammatical. Hafiz, my primary Hindi consultant, also found (6b) to be ungrammatical.

- (6) a.*/? [DP *har ek t̃ʰor*]_i *tʰe d̃ʒaŋo ho ke t̃i be*
 each thief you.HON know.IMPFCT.2 PAST COMP that
dafo| d̃ʒel gija he
 fool jail go.PFV.M.SG PRES.3.SG

‘You know that each and every thief (the fool!) has gone to jail.’

Lit.: ‘Each thief, you know that that fool has gone to jail.’ [MARWARI]

- b. * [DP *har ek t̪ʰor*]_i *ap* *d̪ʒante* *hẽ* *ki*
 each one thief you.HON know.IMPFC.2.PL PRES.HON COMP
t̪i vo bevakuf d̪ʒel gaja *he*
 that fool jail go.PFV.M.SG PRES.3.SG

'You know that each and every thief (the fool!) has gone to jail.'

[HINDI]

It seems that *har ek t̪ʰor* 'each boy' seems to be degraded or ungrammatical in this context, not because it cannot relate to the demonstrative *be* or *vo*, but because *d̪ʒan-* 'know' sometimes acts like an island for movement in Marwari and possibly Hindi. The sentence in (7a), for example, is grammatical but the fronting of an argument out of the finite clause is unacceptable (7b).

- (7) a. *golu d̪ʒane* *he* *ke* [CP *b̪nti ne bʰomli*
 Golu know.IMP.3.SG PRS.3.sg COMP Buntly DAT Bhomli
daj ave]
 liking come.IMP.3.SG

'Golu knows that Buntly likes Bhomli.'

[MARWARI]

- b. * *bʰomlii golu d̪ʒane* *he* *ke* [CP *b̪nti ne*
 Bhomli Golu know.IMP.3.SG PRS.3.sg COMP Buntly DAT
t̪i daj ave]
 liking come.IMP.3.SG

Intended: 'Bhomlii, Golu knows that Buntly likes.'

[MARWARI]

I say *d̪ʒan-* 'know', or the CP complement of *d̪ʒan-* 'know', is sometimes an island for movement because the data is not entirely consistent. Bhatt (2003), for example, says that finite clauses are islands for covert movement in Hindi. (8), for instance, can only have an embedded question interpretation.

- (8) *sita d̪ʒanti* *he* *ki* [CP *radʰa kis-se*
 Sita know.IMP.3.SG PRS.3.SG COMP Raha who.OBL-with
mil rahi he]
 meet PROG.F.SG PRS.3.SG

'Sita knows who Radha is meeting with.' (from Bhatt 2003, p. 502)

Not available: 'Who does Sita know that Radha is meeting?'

[HINDI]

On the other hand, the finite clause complement of $\widehat{d}\bar{z}an-$ ‘know’ does not seem to be an island, as least in some cases.

- (9) $\text{\textit{l}\textit{a}t\textit{a}_i \textit{s}i\textit{t}a \widehat{d}\bar{z}a\textit{n}t\textit{i} \quad h\textit{\epsilon} \quad k\textit{i} \quad [_{CP} \textit{p}\textit{u}\textit{n}\textit{\bar{a}}\textit{m} \quad k\textit{o} \quad t_i \textit{p}\textit{\bar{a}}\textit{s}\textit{\bar{a}}\textit{n}\textit{d} \textit{h}\textit{\epsilon} \quad]}$
 Lata Sita know.IMPFV.F.SG PRS.3.SG COMP Poonam DAT liking
 be.PRS.3.SG

‘Lata, Sita knows that Poonam likes.’ (from Bhatt 2003, p. 503) [HINDI]

While the matrix verb $\widehat{d}\bar{z}an-$ ‘know’ does not always block movement out of the finite CP, it is not entirely clear when it acts like an island and when it does not. The fact that it sometimes acts like an island is likely why (6), *har ek $\widehat{t}\bar{j}^{\textit{h}}or$* cannot be fronted. In (5a), the matrix verb *bud \widehat{z}* ‘think’ does not act like an island in Marwari and allows *har ek $\widehat{t}\bar{j}^{\textit{h}}or$* ‘each student’ to front. If $\widehat{d}\bar{z}an-$ (Marwari)/ $\widehat{d}\bar{z}an-$ (Hindi) ‘know’ is blocking movement, then this is further evidence that the quantifier phrase is base-generated at the demonstrative correlate just as we saw in correlatives.

Hindi and Marwari, therefore, not only allow the correlative to act as an overtly pronounced index of the correlate but will also allow demonstrative phrases and quantifier phrases to enter the syntax in the same way. In the next section, I show that there are also languages which do not have correlatives at all but which allow an overtly pronounced index.

9.3 Overtly pronounced indices in languages without correlatives

Not only is it possible for an index to be overtly pronounced in languages which have correlatives, but it is also possible for a language to have an overtly realized index even if it does not have a correlative construction. In this section, I discuss two examples of this: pronouns in sign language and DP-pronoun constituents in Mandarin Chinese. In sign languages, which all have similar pronominal systems (Sandler and Lillo-Martin 2006), the signing of a pronoun involves an index finger directed toward a locus assigned to a specific noun phrase in the discourse (Section 9.3.1). Like demonstratives in other languages, these pronominal constructions also show deferred reference (Schlenker et al. 2016).

Mandarin Chinese also allows the index of a pronoun to be overt. Proper names and demonstrative phrases are both able to act as indices (Section 9.3.2).

That these languages allow overt indices reveals important information about the semantic composition of indexicals. Preliminary research in Mandarin, for example, indicates that only definite phrases are able to act as indices and indefinite phrases cannot occur in the same position.

9.3.1 Pronouns in sign language

One group of languages which allow an index to be overtly pronounced are sign languages. Lillo-Martin and Klima (1990) and Sandler and Lillo-Martin (2006) conclude that the signing of pronouns in sign languages like American Sign Language (ASL) consist of two components. The first is a pronominal component which they call PRONOUN. The second is a locus or signing space which they argue is an overtly realized index of the pronoun.

While the actual handshapes may differ, Sandler and Lillo-Martin (2006, p. 371, footnote 2) note that all sign languages seem to use the same type of pronominal system. In sign language, the signing of a pronoun involves an index finger directed toward a point in space. When the referent is present, such as in first or second person, the sign points directly to the referent.² It is also possible for a pronoun to be directed toward an arbitrary, default locus realized in front of the signer.

When the referent is not present and the pronoun is used anaphorically, the sign points to a location in signing space assigned to a specific noun phrase in the discourse. This location is called the referential locus, or simple *locus* (Lillo-Martin and Klima 1990). Loci are introduced by noun phrases and mediate the relation between a pronoun and its antecedent (Schlenker 2013). Loci, then, may function as both formal variables and as ‘simplified depictions of what they denote’ (Schlenker et al. 2016).

There are a few ways which pronouns in ASL differ from spoken language. One of these differences is that, because one of the components of the pronoun is a locus, pronouns in sign language may unambiguously pick out a referent.

2. Sandler and Lillo-Martin (2006, p. 378, footnote 6) note that, while Lillo-Martin and Klima (1990) originally assumed that first person and non-first person pronouns are underlyingly the same construction, in more recent work Lillo-Martin has follow Meier (1990) in assuming that first person and non-first pronouns are distinct.

Consider the two sentences (10), for example. In the sign language examples, I follow the glossing conventions used by Sandler and Lillo-Martin. A pointing sign is glossed as *a-IX (referent)*. The lowercase letter *a* indicates the use of a locus. The (*referent*) is what the particular locus refers to or represents in that example. In (10), then, *a-IX* is the signed pronoun whose locus is *a*, where *a* is the locus established as representing the governor.

- (10) a. a-GOVERNOR FEEL a-IX (GOV) INTELLIGENT
 ‘The governor_i thinks he_i is intelligent.’
 (from Sandler and Lillo-Martin 2006:375) [ASL]
- b. a-GOVERNOR FEEL b-IX (he) INTELLIGENT
 ‘The governor_i thinks he_j is intelligent.’
 (from Sandler and Lillo-Martin 2006:375) [ASL]

In spoken language, the sentence (10) is ambiguous, as shown in (11). The pronoun may be interpreted as referring either to the governor, so that the governor thinks of himself as intelligent, or to someone other than the governor.

- (11) The governor_i thinks he_{i/j} is intelligent.

In ASL, though, neither (10a) nor (10b) is ambiguous. (10a) can only mean that the governor thinks of himself as intelligent, and (10b) can only mean that the governor thinks of someone other than himself as intelligent.

Sign language pronouns are true pronouns, though, and are similar to spoken language in many ways. For instance, they obey at least of the syntactic constraints on binding studied in syntax, and the same kind of ‘donkey anaphora’ sentences found in spoken language can also be found in sign language (Schlenker 2013, 2014).

Lillo-Martin and Klima (1990) propose that a pronoun in sign language is made up of two components. The first, which they call PRONOUN, is similar to a third person pronoun in English. Much as indexicals in spoken language are often marked with a subscripted index in formal notation, the signed pronoun is marked by a referential index, as well. But, unlike spoken language, this coindexing is overtly realized in sign language as the locus of the pronoun. Sandler and Lillo-Martin (2006, p. 378) likewise conclude that ‘for ASL, unlike for spoken languages, the reference indices can be overtly realized, in the form of distinct locations in signing space.’

Assuming this analysis, the structure of a signed pronoun in ASL and other signed languages is the same as the English pronoun *it* except that the index component and the pronoun are signed overtly.

(12)

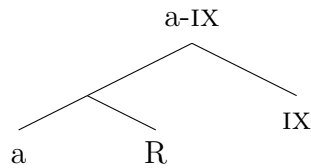

The location associated with the noun phrase is then taken as the overt index of the pronominal index. This index is then related to the interpretation in the main clause.

Schlenker et al. (2016) points out that sign language exhibits a temporal pronoun as well. Where spoken languages often have an overt temporal pronoun which is pronounced differently from individual-denoting pronouns, ASL pronouns may have nominal, temporal, locative, and modal uses. Just as we have seen for nominal pronouns, an antecedent in the discourse is associated with a locus or point in space. The pronoun itself involves pointing to that point in space. In the sentence in (13), for example, existential antecedents establish two loci. The pronominal forms then retrieve these loci by pointing.

(13) *Context*: Every week I play the lottery.

7 IX-1 [SOMETIMES WIN]. IX-1 [SOMETIMES LOSE]. IX-a IX-1 HAPPY.

‘Sometimes I win. Sometime I lose. Then [=when I win], I am happy.’

(from Schlenker et al. 2016, p. 5) [ASL]

The ability of a pronoun to take a location as an index also allows for deferred reference in signed pronouns. As Schlenker et al. (2016, p. 6) explains, ‘[W]hen an individual has been associated with a spatial location in previous discourse, one can refer to him by pointing toward the locus *associated with the location*’ (emphasis his). An example of this is (14). The notation *a+* and *c+* here is used to indicate that the sign is pointing to a position slightly higher than the loci *a* and *c*.

(14) JOHN [WORK IX-1 FRENCH CITY]_a SAME [WORK IX-c AMERICA CITY]_b

‘John does business in a French city and he does business in an American city.’

IX-a IX-1a HELP IX-a+. IX-b IX-1b NOT HELP IX-b+.

‘There [=in the French city] I help him. ‘There [=in the American city]

I don’t help him.’ (from Schlenker et al. 2016, p. 6) [ASL]

While the free translation for (14) is given as ‘There, I help him,’ Schlenker says that the two pronouns can be thought of as referring to *John-in-the-French-city* and *John-in-the-American-city*.

Schlenker calls the relationship between a locative referent and a nominal pronoun *locative shift*, but this is really the same type of deferred reference seen in Chapter 2, where a locative single headed correlative relates to a nominal demonstrative.

The ability to overtly realize the index of a pronoun or demonstrative is not restricted to correlatives or to MIA languages. The fact that there are spoken languages which can overtly pronounce an indexical argument is further evidence that the index is a lexical item and an argument of the indexical phrase (Elbourne 2008). These constructions are also further support that syntax of the pronoun in sign languages such as ASL is syntactically the same as in spoken languages.

9.3.2 Mandarin Chinese

Mandarin-Chinese is a Sino-Tibetan language, unrelated to the MIA languages which have been the primary focus of this dissertation. Mandarin has neither free relatives nor a correlative construction such as we have seen for Hindi, Marwari, and other MIA languages, but Mandarin does allow the index of a pronoun to be pronounced overtly. Consider the follow example of kinship possession in Mandarin.³

(15) [_{PronP} *Zhangsan ta baba*] *hen nianqing*
 Zhangsan he father very young

‘Zhangsan’s father is very young.’ [MANDARIN]

For now, I will assume that there is a covert adposition *of* linking *ta* ‘he’ and *baba* ‘father’ as an analysis of Mandarin possession is not relevant to the current analysis. What is significant in this example is the relationship between the proper name *Zhangsan* and the pronoun *ta* ‘he’. I propose that, like the correlative construction, *Zhangsan* is the indexical argument of the pronoun. The pronominal phrase *Zhangsang ta* ‘Zhangsan he’ then has the following structure in (16).

3. Many thanks to Fangfang Niu, Annette Zhao, and Chen Wang for the Mandarin Chinese sentences and judgments in this and following examples.

(16)

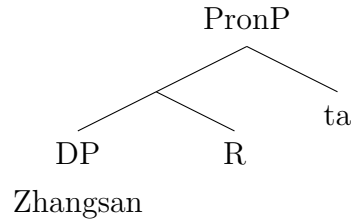

Like the correlative-correlate constituent, *Zhangsang ta* ‘Zhangsan he’ is not restricted to the left periphery but may appear inside of the main clause. In (17), for example, *Zhangsang ta baba* ‘Zhangsan’s father’ is the object of the main clause and occurs in object position.

- (17) *Lili Guyong le* [_{PronP} *Zhangsan ta baba*]
 Lili hire LE Zhangsan he father
 ‘Lili hired Zhangsan's father.’ [MANDARIN]

It is not just possessive phrases which allow this type of construction. As (18) shows, participial phrases may also act as overtly pronounced indices in Mandarin. In (18a), the object is the participial phrase

- (18) a. *Zhangsan da-le* [_{Part} *zhan-qilai de*]
 Zhangsan hit-ASP stand-up DE
 ‘Zhangsan hit the one who stood up.’ [MANDARIN]
- b. *Zhangsan da-le* [_{DemP} [_{Part} *zhan-qilai de*] *na-ge nvhai*]
 Zhangsan hit-ASP stand-up DE that-CL girl
 ‘Zhangsan hit the girl who stood up.’ [MANDARIN]
Lit.: ‘Zhangsan hit the one who stood up, that girl.’

Movement in Mandarin is more restricted than Hindi and Marwari, which freely allow arguments to front to mark topicality or focus. Mandarin will not allow a PronP generated in the object position to front to the left periphery, as shown in (19a). It is also not possible for a non-pronominal object to be fronted, as shown in (19b).

- (19) a. * [*Zhangsan ta baba*]_i *Lili Guyong le* _{t_i}
 Zhangsan he father Lili hire LE
Intended: ‘Zhangsan's father, Lili hired.’ [MANDARIN]

- b. **Zhangsan_i Lili Guyong le t_i*
 Zhangsan Lili hire LE

Intended: 'Zhangsan, Lili hired.'

[MANDARIN]

Preliminary research seems to indicate that, like the Hindi and Marwari examples in Section 2, only DPs which involve an event and which are unambiguously definite. For instance, it is possible for a demonstrative phrase to act as the overt index as shown in (20a).

- (20) a. [_{PronP} [_{DemP} *na ge xue sheng*] *ta*] *baba*
 that CL student he father

'that student's father' / *Lit.:* 'that student, his father'

b.

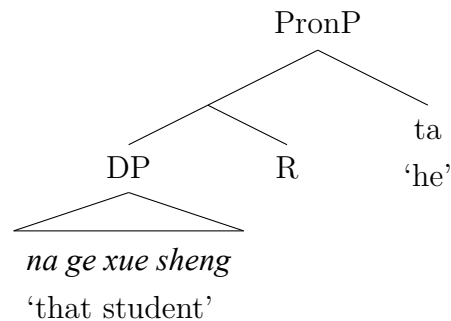

The pronominal phrase in (20a) then has the structure in (20b).

While it is possible for a demonstrative phrase to act as an argument of the pronoun, it is not possible for an indefinite to enter the syntax in the same way. Mandarin Chinese does not have definite or indefinite articles, but it is possible to force an indefinite reading with the numeral *yi* 'one.' In (21), the DP *yi ge xue sheng* 'one student' is restricted from acting as an argument of the pronoun.

- (21) * [_{PronP} [_{DP} *yi ge xue sheng*] *ta baba*]
 one CL student he father

Intended: 'one student, his father'

[MANDARIN]

It is not just definiteness or indefiniteness which determines whether a phrase can act as an overt index, at least in languages which do not have an overt determiner. Even with a definite reading, (22) is unacceptable.

(22) * [PronP [DP *xue sheng ta*] *baba*
student he father

Intended: 'the student, his father'

[MANDARIN]

Thus, Mandarin only allows the index to be overtly pronounced if the morpheme which carries definiteness, such as a demonstrative or proper name, is overt. Even when an NP is definite according to the context, the DP cannot act as an index. I hypothesize that indexical can only take definite descriptions as indices, whether or not the index is overt.

9.3.3 Summary

The ability of phrases which are not correlatives or free relatives to act as overtly pronounced indices can give further insight into the nature of the index and its relationship with the demonstrative or pronoun.

The analysis I have presented in this dissertation predicts that the index of a demonstrative or pronoun can be overtly pronounced by phrases other than a correlative or free relative. Further, it appears that the most likely phrases to act as overtly pronounced indices are those which involve an event. Relative clauses, including prenominal relative clauses, for instance, seem to be able to act as overtly pronounced indices. Demonstrative phrases similarly involve an event or situation. While this is just a short sketch of overtly pronounced indices outside of correlatives/free relatives, the data suggests that the demonstrative can take phrases of type <s,e> as an argument, rather than simply entities of type e.

I show in Section 9.4 that the ability or non-ability of participials in Marwari to act as overtly pronounced indices also depends on definiteness, where definiteness is also dependent on a situation. While all of the languages which I have looked at in this chapter lack articles, this predicts that a language which does have definite and indefinite articles will only allow a definite DP to act as an overt index. This may be a syntactic restriction or, more likely, is a semantic restriction related to the definite reading of indexicals.

9.4 Why can't participials be indices?

Indexicals seem to allow entities which are either indexical or involve an event. This may include a demonstrative phrase modified by a postnominal relative clause (MIA), quantifier phrases (MIA), a pronoun (Sign Language and Mandarin) or a prenominal relative clause (Mandarin). It is not necessarily the case, though, that all DPs or phrases which denote entities and which involve clauses may act as an overtly realized index. There are certain cases of participial clauses, or prenominal relatives, in Hindi and Marwari which cannot enter the syntax as an argument of an indexical.⁴ In this section, I suggest that, at least for Marwari, certain prenominal relative clauses cannot act as indices because they are not definite.

In this section, I assume that a participial clause in Hindi and Marwari is a variety of prenominal relative clause. A prenominal relative clause is a relativizing phrase which does not include a relative pronoun and, in MIA, does not include a relative particle either clause initially or clause finally. Participial relatives, which sometime occur postnominally cross-linguistically, are prenominal in MIA. These are relatives whose verb has participial inflection which is distinct from normal infinitival inflection (Vries et al. 2002). In (23), for instance, the participial relative *miru nāku iccina* 'you gave me.PTPL' modifies the NP *pustukamu* 'book'.

- (23) [DP [_{PART} *miru nāku ic-cin-a*] *pustukamu*] *cirigipō-yin-adi*
 you.PL me give-PRET-PART book.NOM tear.up-PRET-3.SG

'The book you gave me has been torn up.'

Lit.: 'The you-gave-to-me book has been torn up.' (*from*

Vries et al. 2002, p. 17)

[TELEGU]

Kachru (2006) describes two types of participial clauses in Hindi, the present participle and the past participles, based on the participial inflection. Each of the two types may have what he calls an adjectival reading, in which the participial modifies an NP, and the adverbial reading which does not include an NP.

The present participial in Hindi is derived from what looks like the imperative aspect marking *-ta/ti*, which is inflected for gender, number, and case. The participial marked verb is then followed by the perfective form of *ho-* 'be,

4. This problem was initially pointed out by Veneeta Dayal (p.c.).

happen' which is of the form *hua*. A example of a simple adjectival, present participial is (24), below.

- (24) *dəɽta* *hua* *ləɽka* *ətʃənək* *ruk*
 run.PTPL.M.SG happen.PFV.M.SG boy.M.SG suddenly stop
gəja
 go.LGT.PFV.M.SG

'The boy who was running suddenly came to a stop.'

Lit.: 'The running boy stopped suddenly.' (from Kachru 2006, p. 226)

[HINDI]

The participial phrase itself is a true CP and may include PP modifiers, arguments, and adverbial phrases. In (25), for instance, the participial phrase *barɪf mē bʰɪgti hui* 'in the rain become wet' modifies the NP *ləɽkija* 'girls'.

- (25) *barɪf* *mē bʰɪgti* *hui* *ləɽkija* *həs*
 rain.OBL in be.wet.PTPL.F.SG happen.PFV.F.SG girl.F.PL laugh
rəhi *thĩ*
 PROG.F.PL PAST.F.PL

'The girls getting wet in the rain were laughing.' (from Kachru 2006, p. 227)

[HINDI]

The present participial clause does not necessarily have to modify a noun phrase. Kachru calls this the adverbial function of the participle. For instance, the participial phrase *dəɽte hue* 'running' in (26) is said to be functioning as an adverbial.

- (26) *kʰel* *kətəm* *hone* *pər bətʃːa* *dəɽte* *hue*
 game finish be.INF.OBL on children.M.PL run.PTPL happen.M.PL
gʰər *aja*
 house.M.SG come.PFV.M.SG

'The children came home running when the game ended.' (from

Kachru 2006, p. 227)

[HINDI]

There are two varieties of prenominal relative clause in Marwari – those which include a noun phrase (example 27a) and those which do not (example 27b).

- (27) a. [PART *bʰag* *toɾo* [NP *tʰoro*]] *pəɾ* *gijo*
run.away PART boy.M.SG fell go.PFV.M.SG
`The boy who ran away fell down.'
Lit.: `The running away boy fell down.' (*adapted from* Kachru 2006)
[MARWARI]
- b. [PART *mol lev* *tʰoji*] *bʰomli* *gəmaj dijo*
buy take.LGT PART Bhomlii lose give.LGT.M.SG
`Bhomlii lost the things which had been bought.'
[MARWARI]

Marwari does not allow a prenominal relative with an overt NP to enter the syntax as an overt index, though.⁵ This was tested both in a fronted position, where the demonstrative is in the main clause, and immediately preceding the demonstrative.

- (28) * [PART *bʰag* *toɾa* *tʰoro*]_i *polis* *t_i* *un-ne*
run.away PART boy.M.SG police that.OBL-ACC
pəkəɖ lijo
catch take.PFV.M.SG
Intended: `Run-away boy, the police caught him.'
[MARWARI]

The participial which does not include an NP, on the other hand, can be an index (example 29a). Example (29b) shows that this second participial construction does not necessarily need to be fronted but may be found in an embedded clause, below the subject preceding the demonstrative, just as we saw for the single headed correlative construction.

- (29) a. [PART *bʰomli* *mol lev* *tʰoji* *hi*] *un-ne*
Bhomlii buy take.LGT PART PST.F.SG that.OBL.SG-ACC
gəmaj dijo
lose give.LGT.M.SG
`Bhomlii lost the things which were bought, those.'
[MARWARI]
- b. *bʰomli* *hotʃijo* *ke* *ba* [PART *mol*
Bhomlii thought.PFV.M.SG COMP that.F.SG buy

5. This was tested with two Marwari speakers from Sarechan but not with informants from other varieties.

lev tʰoji] un-ne gəmaj dijo
 take.LGT PART that.OBL.SG-ACC lose give.LGT.M.SG

'Bhomlii thought that she lost, the bought things, them.' [MARWARI]

Neither Hindi nor Marwari have an overt definite or indefinite article, so an unmarked noun phrase is ambiguous between a definite or indefinite interpretation. Looking more closely at these constructions, we find that despite their similarities, there is a significant difference between them. The first prenominal RC, involving an NP, may take an indefinite D-head.

(30) *polis ek bʰag toṛa tʰora ne pəkəd lijo*
 police one run.away PART boy.OBL.M.SG catch ACC take.LGT.PFV.M.SG

'Police caught one/a run-away boy.' [MARWARI]

The second construction, which does not include an NP, can only take a definite D-head and cannot take an indefinite.⁶

(31) *bʰomli {*ek/*do/?bo/be/doi} mol lev tʰoji*
 Bhomlii one/two/that/those/both buy take.LGT PART
gəmaj dijo
 lose give.PFV.M.SG

'Bhomlii lost {*one/*two/?that/those/both} bought things.' [MARWARI]

This indicates that, while the *toṛa* construction is an indefinite nominal, the *tʰoji* construction can only have a definite reading. This is consistent with the other types of phrases which can enter the syntax as an index – correlative clauses, demonstratives, and proper names.

There is a third type of verb-phrase relative type construction in Marwari. This construction includes a noun phrase followed by a verb root with a *-ta* suffix.

(32) *dadi d̄zi [PART kitab mol levə-ta ʔi]*
 Grandmother.M.SG HON book.F.SG buy take.LGT-TA EMPH
pʰēnk di
 throw.away give.LGT.PFV.F.SG

6. While my consultants said that *bo* 'that' is all right, they said that the plural demonstrative *be* 'those' is much better.

'Grandmother threw away the book which had been bought.' [MARWARI]

This *ta* construction is possible with either a singular demonstrative or *ek* 'one/a'.

- (33) *dadi* $\widehat{d\acute{z}i}$ [NP/DP {*ek/bo/*be*}] [PART *kitab* *mol*
 Grandmother.F.SG HON one/that/those book.F.SG buy
levə-ta *ʔi*]] *p^hěnk* *di*
 take.LGT-TA EMPH throw.away give.LGT.PFV.F.SG

'Grandmother threw away {a/that/*those} book which had been bought.'

[MARWARI]

Despite the fact that this construction can take a demonstrative D-head, it still cannot enter into a overt index construction, whether within the main clause, as shown in example (34), or in a fronted position.⁷

- (34) * *dadi* $\widehat{d\acute{z}i}$ [PART *kitab* *mol leva-ta* *hii*]
 Grandmother.F.SG HON book.F.SG buy take.LGT-TA that.M.SG
bo *p^hěnk* *di*
 throw.away give.LGT.PFV.F.SG

Intended: 'Grandmother threw away, (the/a) book which had been brought, that.'

[MARWARI]

In conclusion, there are three variations of the participial prenominal relative clause or, more accurately the eventive nominal, in Marwari. Two of these, the *t^hoji* construction and the *ta* construction may take an indefinite quantifier such as *ek*. These same two constructions are not able to enter the syntax as an overt pronunciation of an index.

7. Although the demonstrative *bo* can be used with the *ta* construction, in the one example I have this still does not allow the construction to act as an overt index.

- (i) *bo kitab mol levə-ta* *dadi* $\widehat{d\acute{z}i}$ *bo p^hěnk* *di*
 that book buy take.LGT-TA grandmother HON that throw.away give.LGT.PFV.F.SG

Intended: 'That book which had been brought, grandmother threw that away.'

If this were grammatical, it would be even further evidence toward the idea that an index must be both involve an event or situation and be definite. The fact that it is not grammatical is not evidence against this, though, as there are other factors at play which may be making the construction ungrammatical.

The third variation, the *toro* construction, is only able to take definite quantifiers or demonstratives and is ungrammatical with an indefinite quantifier. This suggests that the *toro* nominal always has a definite interpretation, but the covert definite D head may be superseded by an overt definite demonstrative. This construction is also the only eventive nominal of the three constructions which is able to act as an index.

While the exact contribution of this construction needs to be explored more in depth, these examples along with the other types of phrases which can enter the syntax as an index indicate that a phrase must be definite in order to enter the syntax as an index. A prenominal relative clause or eventive nominal, while involving an event in its semantics, is not definite and therefore cannot be the argument of an indexical.

9.5 Summary and theoretical implications

The nominal and adverbial correlative construction, common throughout MIA languages, has customarily been classified as a specific type of relativizing structure. Under the analysis that I have presented in this dissertation, the correlative construction is not a relativizing structure at all but is simply the overt pronunciation of the indexical argument of a demonstrative or pronoun. In the case of the correlative, the overtly pronounced index just happens to be a free relative, but proper names, demonstrative phrases, and prenominal phrases can all act as indices, as well.

In summary, the single headed correlative construction has the syntactic features in (35, see Chapters 2 and 4).

- (35) Features of the single headed correlative (SHC) construction:
- (a) The SHC is an independent clause headed by a relative pronoun which denotes an individual of type *e*. Both the relative phrase and the demonstrative phrase may include an overt, independently generated NP.
 - (b) There must be a corresponding, appropriate correlate in the main clause. This is the *demonstrative requirement* (Dayal 1996).
 - (c) MIA languages, including Hindi and Marwari, allow the SHC to be fronted away from the demonstrative. This movement is restricted by

islands for overt movement and the Coordinate Structure Constraint (Bhatt 2003; Ross 1967).

- (d) Semantically, SHCs are definite and denote a unique, presupposed individual of type *e* (see Chapter 6).

The relationship between the correlative and its correlate in the main clause is a syntactic one which follows from the internal structure of the indexical itself (see Chapter 3). Where a demonstrative phrase normally takes a covert index which gets its meaning through variable interpretation (36, Elbourne 2008), the demonstrative correlate in a correlative construction may take a correlative (which is really a free relative) as an overtly pronounced index (37).

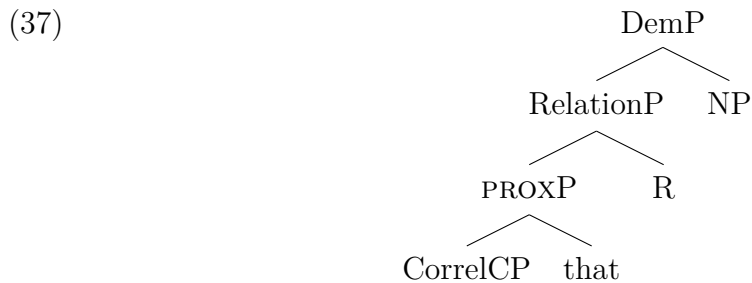
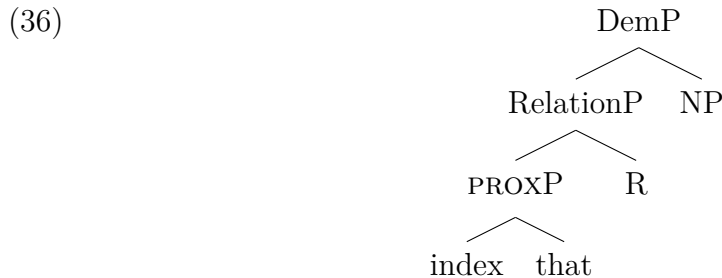

Because both nominal and adverbial correlatives denote individuals, either one is able to act as the index of a nominal demonstrative phrase (see Chapter 5).

Other types of definite phrases are able to act as overtly pronounced indices, as well (see Section 9.2 and Section 9.3). Hindi and Marwari both allow demonstrative phrases and (indexical) quantifier phrases to act as the index of a demonstrative phrase, with the structure (38). Some Marwari prenominal participial clauses can also appear in this position.

(38)

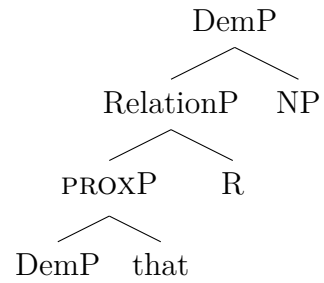

Like the demonstrative, pronouns also allow the index to be overt (see Chapters 2 and 3). Cross-linguistically, both pronouns and demonstratives are able to act as correlates. The Bangla correlative construction, for instance, may employ both pronominal and demonstrative correlates.

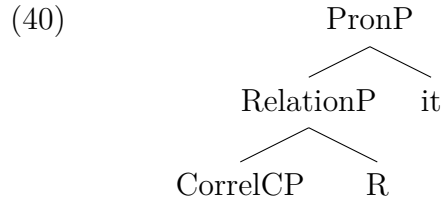
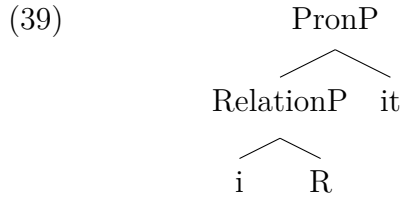

As Mandarin Chinese and sign languages show, both proper names (41) and definite locations are able to act as overt indices of pronouns. Like Hindi and Marwari, Mandarin allows overt DemP indices, as well.

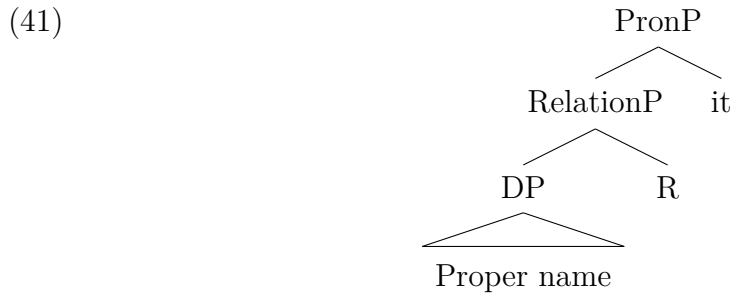

Adverbial correlative constructions, which prototypically involve a correlative headed by an adverbial relative phrase which relates to an adverbial correlate in the main clause, are also true correlative constructions with the same syntactic features as nominal correlative (see Chapter 4). The adverbial correlate is, in fact, an indexial and allows both a direct reference and deferred reading just as we saw for nominal demonstratives (Nunberg 1993) (see Chapter 5). Like adpositional phrases, adverbial demonstratives are defined in terms of a reference object. In locative PPs, the PP itself denotes a set of vectors defined, ultimately, in terms of the location of the reference object. The locative adverbial is similarly defined in terms of the location of some object, where that object is the individual contributed by the relation phrase – what Nunberg might call the interpretation.

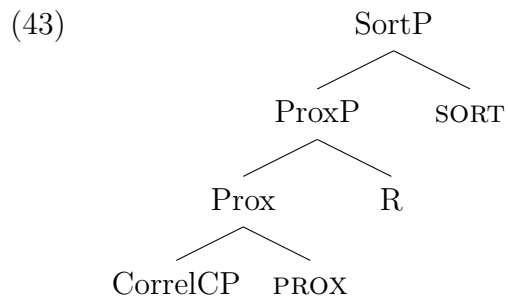
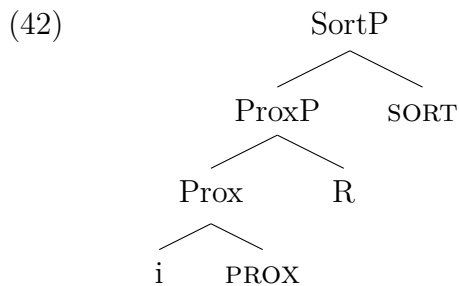

An adverbial demonstrative includes a sort-phrase which takes this object as

an argument and yields a location, manner, time, or kind. As individuals, both nominal and adverbial correlatives are able to act as indices of an adverbial demonstrative.

What it is about these particular phrases which allows them to act as the indexical argument of a demonstrative or pronoun? I posit that the index must be a unique, presupposed individual. That is, the index must have the semantic contribution of a definite description. Further, phrases which have a definite interpretation but which may also be indefinite do not seem to be able to occur in this position. This may indicate that the definiteness reading of these constructions is not due to a covert D head but comes from pragmatic processes.

Single headed correlatives (or free relatives), therefore, are able to act as an overt index because they denote unique, presupposed individuals. Like questions (Cable 2010; Kotek 2014), the wh_{RC} -phrase includes a Q particle, Q_{COR} . Q_{COR} then moves out of the relative phrase and raises to Spec-CP (see Chapter 6) in both nominal (44) and adverbial (45) correlatives.

(44)

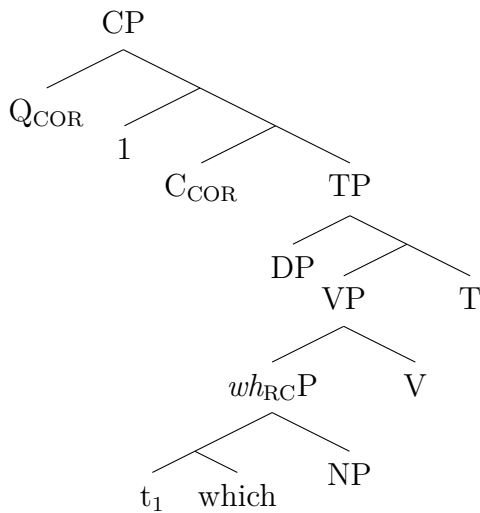

(45)

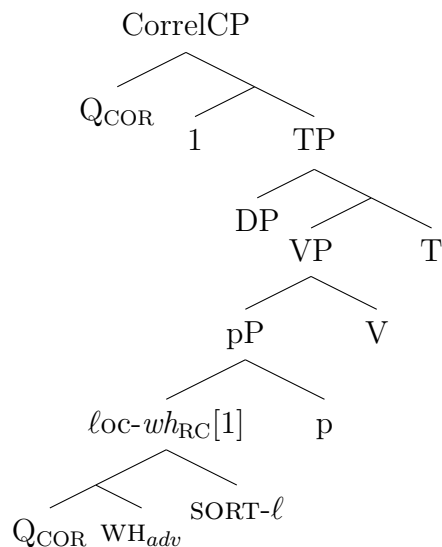

Like the locative PPs and the adverbial demonstrative, the adverbial relative phrase includes a sort-phrase of type $\langle e, \ell \rangle$. This allows the *wh*-element to take Q_{COR} as an argument. It is the raising of Q_{COR} to Spec-CP which gives the correlative its definite interpretation and which gives the adverbial correlative its denotation as an individual.

Of course, not all languages have a correlative construction or allow covert indices. Some languages, like English, have free relatives but do not allow the index to be overt. Mandarin Chinese, on the other hand, lacks free relatives but does allow the index to be overtly pronounced. Thus, Mandarin does not have a correlative construction, per se. There are, of course, many remaining questions regarding the ability of a language to overtly pronounce an index. Further investigation into binding effects and similar features found in the correlative construction may add further evidence that the types of sentences presented in this chapter are truly overtly pronounced indices. It would also be beneficial to test whether these types of constructions have the same restrictions on movement out of islands that we saw in Hindi and Marwari.

The combination of an overtly pronounced index and the availability of a multiple-*wh* construction also allows for a multi-headed correlative construction.

(46) The syntactic features of the multi-headed (MHC) construction:

- (a) Broadly, the number of relative pronouns in the correlative clause must equal the number of demonstratives or indexicals in the main clause. More specifically, the number of individuals described by the

relative pronoun(s) in the multi-headed correlative must correspond to the number of referents selected by the indexicals in the main clause.

- (b) MHCs have both a singular reading and a pair list reading, much like *wh*-questions. The pair list reading shows point-wise uniqueness and exhaustivity.
- (c) In Hindi, the order of the demonstratives in the main clause must correspond to the order of the demonstratives in the main clause (Dayal 1996). While bare demonstratives of the same noun class (i.e., which are both either masculine or feminine) in Marwari seem to have the same restriction, this restriction does not seem to hold for all Marwari MHCs.

I propose that the multi-headed correlative does not adjoin to IP but is base-generated inside of the main clause at, at least, the higher demonstrative (see Chapter 7). Further, MHC which relates to a plural demonstrative is subject to the Coordinate Structure Constraint (Ross 1967) and is therefore base-generated within the same constituent as the demonstrative. The MHC also acts as the index of the lower demonstrative in the structure, and island effects show that there is movement between the two demonstratives.

A language may, therefore, have a multi-headed correlative construction if it allows the index to be overtly pronounced and if it allows multiple-*wh* constructions such as multiple-*wh* questions. Further, I hypothesize that, if a language does not allow an overt index to move away from the correlate, the MHC construction will be unavailable.

To conclude, the correlative construction is really a combination of two distinct constructions. The first is the correlative itself, which I assume to be a free relative. The second is the overt pronunciation of the index of demonstratives, pronouns, or other types of indexicals. In MIA languages and other languages cross-linguistically, these two structures come together as what is known as the correlative construction.

Appendix A

Some brief comments on Marwari grammar

A.1 An Introduction to Marwari

While this dissertation is primarily concerned with the syntax of Marwari at the clausal level, it is often helpful to have a general idea of the basic grammar of the language. For this purpose, I have compiled the following very brief grammatical sketch. This is not intended to be a comprehensive analysis of Marwari grammar but is simply an introduction to Marwari in the hopes that it will help the reader and give some insight into the Marwari language.

Marwari is a Modern Indo-Aryan language spoken in the Marwar region of northwest India and in Pakistan. My fieldwork, and this grammar sketch, is focussed on Marwari spoken in Jodhpur District, Rajasthan.

A.2 Marwari Phonetics and Phonology

I have not attempted to do a thorough phonological analysis of Marwari. In most cases, in order to decide on the right phoneme, I relied largely on native speaker intuitions and how speakers chose to write Marwari using Devanagari. There are a few cases, though, where speakers would not write Marwari phonetically, for example when theyT would defer to Hindi spelling. In these cases, I have transcribed the Marwari as it is pronounced.

Table A.1 shows the phonemes used in Marwari and the corresponding letter in Devanagari. There are a few phonemes found in Marwari which are

not represented by Devanagari; in these cases, a slightly modified or archaic Devanagari phoneme is often used.

Devanagari is a syllabic script in which each letter or symbol represents a consonant and a vowel. क, for example, is pronounced /kə/. For the sake of clarity, I have only included the consonant in the table of phonemes.

In addition to these, Marwari also has four affricates, as shown in Table A.2, as well as two additional aspirated consonants which are not found in Hindi.

Because Devanagari represents both the consonant and vowel, Table A.3 shows the vowels in Marwari along with the phoneme क (/k/).

In (47), I have listed a few observations on Marwari phonology. Many of these were also noted by Magier (1983).

(47) Brief comments on Marwari phonology

- There is a great deal of variation between /s/, /h/ and /ʔ/. In some cases, /s/ is pronounced as /h/, and /h/ is pronounced as /ʔ/. In other cases, these seem to be in free variation and may be used interchangeably by the same speaker. See Magier (1983) for a more in depth discussion.
- The pronunciation of the phoneme /v/ often ranged between /v/, the bilabial fricative /β/, and the bilabial glide /w/. This also depends on the variety. Osian Marwari speakers, for instance, consistently pronounced the distal demonstratives with a bilabial plosive (/bo/ and /ba/) and would correct /va/ to /ba/.
- Marwari avoids consonant clusters, including ending on syllable and beginning the next with a consonant. Speakers varied between *undro* and *undəro* ‘mouse’, for example. Most consonant clusters which come word-initially occur in words borrowed from English. *skul* ‘school’, for instance, is often pronounced *iskul*.

A.3 Base Word Order

Marwari is an SOV language but both arguments and adpositional phrases can be fronted (sometimes referred to as scrambling) to mark focus or topicality.

	Bilabial	Labiodental	Dental	Alveolar	Retroflex	Palatal	Velar	Glottal
Plosive	<i>p</i> प	<i>b</i> ब	<i>t</i> त	<i>d</i> द	<i>ʈ</i> ट	<i>d̪</i> ड	<i>k</i> क	<i>g</i> ग
Aspirated Pl.	<i>pʰ</i> फ	<i>bʰ</i> भ	<i>tʰ</i> थ	<i>dʰ</i> ध	<i>ʈʰ</i> ठ	<i>d̪ʰ</i> ढ	<i>kʰ</i> ख	<i>gʰ</i> घ
Nasal	<i>m</i> म			<i>n</i> न			<i>ŋ</i> ङ	
Tap				<i>r</i> र		<i>ɽ</i> ङ		
Fricative		<i>f</i> फ		<i>s</i> ह, .स	<i>ʂ</i> ङ			
Approximant		<i>v</i> व						
Lateral Approx.				<i>l</i> ल		<i>ɭ</i> ळ		

Table A.1: Marwari consonants and the corresponding letter in Devanagari

Affricates	$\widehat{tʃ}$ च	$\widehat{dʒ}$ ज
Aspirated Aff.	\widehat{t}^h छ	\widehat{d}^h झ
Aspirated Nasal		m^h म्ह
Aspirated Approx.		v^h वह

Table A.2: Other consonant in Marwari and the corresponding Devangari

	Front	Central	Back
Close	<i>ki</i> की		<i>ku</i> कू
		<i>ki</i> कि	<i>ku</i> कु
Close-mid	<i>ke</i> के, कै		<i>ko</i> को
		<i>kə</i> क	
Open-mid	<i>kɛ</i> के, कै		
Open			<i>ka</i> का

Table A.3: Marwari syllabic vowels with the corresponding Devanagari

- (48) [SUBJ *raam*] [IO *sita ne*] [DO *ek tofu*]
Raam Sita ACC one gift.M.SG
[v *dijo*] [Aux *ho*]
give.PFV.M.SG pst.M.SG

'Raam gave one book to Sita.'

In most cases, the verb will agree with the subject unless agreement is blocks. Then the verb will agree with the object, indirect object, or take default masculine singular agreement, with priority given in that order.

A.4 The Marwari Noun Phrase

The Marwari noun phrase is right headed, with the noun following the demonstrative, number, and adjectives (in that order).

A.4.1 Pluralization of nouns

Marwari has two noun classes, feminine and masculine. As a general rule, masculine nouns end in *-o*, which becomes *-a* when plural, and feminine nouns end in *-i* which becomes *-ijã* when plural. There are a large numbers of nouns

which do not follow this pattern, though, and the noun class is only apparent through the agreement patterns.

Tables A.4 and A.5 show the different patterns of pluralization which appear in Marwari noun phrases. I have divided masculine nouns into four classes. Nouns which pluralize by changing an *-o* ending to *-a* are the most common. There are a few masculine nouns which add an *-a* ending to a word which ends in a consonant or a vowel other than *-o* without changing the root.¹ Many nouns, both masculine and feminine, do not change form when pluralized.

Class	Singular	Plural	SG.OBL	PL.OBL	
<i>o</i> → <i>a</i>	<i>t̃foro</i>	<i>t̃fora</i>	<i>t̃fora</i>	<i>t̃fora</i>	‘boy’
	<i>a o</i>	<i>a a</i>	<i>a a</i>	<i>a a</i>	‘shelf’
+ <i>a</i>	<i>t̃ʃəmət̃f̃</i>	<i>t̃ʃəmət̃ʃa</i>			‘small spoon’
	<i>t̃ʃaku</i>		<i>t̃ʃaku</i>	<i>t̃ʃakua</i>	‘knife’
No change.	<i>bijao</i>	<i>bijao</i>	<i>bijao</i>	<i>bijao</i>	‘wedding’
	<i>med̃ʒ</i>	<i>med̃ʒ</i>	<i>med̃ʒ</i>	<i>med̃ʒ</i>	‘table’
Only OBL changes.	<i>m̃nək</i>	<i>m̃nək</i>	<i>m̃nək</i>	<i>m̃neka</i>	‘man’
	<i>tabər</i>	<i>tabər</i>	<i>tabər</i>	<i>tabəra/tabra</i>	‘child, student’

Table A.4: Masculine Nouns: Pluralization and Oblique Form

While most feminine nouns are pluralized by changing *-i* to *-ija*, others also add an *-a* ending directly onto the singular form of the noun.

Class	Singular	Plural	SG.OBL	PL.OBL	
<i>i</i> → <i>ijā</i>	<i>t̃fori</i>	<i>t̃forijā</i>	<i>t̃fori</i>	<i>t̃forijā</i>	‘girl’
	<i>tuḍ̃ʒori</i>	<i>tuḍ̃ʒorijā</i>	<i>tuḍ̃ʒori</i>	<i>tuḍ̃ʒorijā</i>	‘lockbox’
+ <i>a</i>	<i>kitab</i>	<i>kitaba</i>	<i>kitab</i>	<i>kitaba</i>	‘book’
	<i>mut̃ʃ</i>	<i>mut̃ʃa</i>			‘mustache’
No change.	<i>dukan</i>	<i>dukan</i>	<i>dukan</i>	<i>dukan</i>	‘store’

Table A.5: Feminine Nouns: Pluralization and Oblique Form

1. There were very few examples of masculine nouns which add an *-a* ending to noun roots which end in a consonant, so the full paradigm is not available.

Like other MIA languages, nouns and adjectives take a different form when they are inside of an adpositional phrase (also shown in Tables A.4 and A.5). This is often referred to as *oblique case*, or the oblique form of the noun.

Most masculine Marwari noun classes do not distinguish between the singular and plural oblique form. For many feminine nouns, on the other hand, the oblique form of the noun phrase is the same as the singular or plural forms. There is an important exception to this, though. Some masculine nouns which do not show any overt difference between the singular and plural do add an *-a* ending in the plural oblique form (see Table A.4). I have classified these as a separate noun class in order to reflect this difference.

A.4.2 Adjectives and agreement

Marwari adjectives agree with the noun phrase and, in many cases, show overt feminine or masculine agreement, ending in *-o*, *-a*, or *-i*. Examples of this are shown in Table A.6.

Singular		Plural		
Masc.	Fem.	Masc.	Fem.	
<i>dig:o</i>	<i>dig:i</i>	<i>dig:a</i>	<i>dig:i</i>	‘long, tall’
<i>futro</i>	<i>futri</i>	<i>futra</i>	<i>futri</i>	‘beautiful’
<i>ifoto</i>	<i>ifoti</i>	<i>ifota</i>	<i>ifoti</i>	‘small’

Table A.6: Marwari Adjectives: Agreement and Oblique Form

Adjectives – at least, adjectives which show masculine agreement – also show oblique case when they modify a noun inside of an adpositional phrase. Because the oblique case marking on masculine adjectives is the same as the plural agreement marking, these are ambiguous between singular and plural oblique agreement.

Other adjectives do not change form regardless of the noun class of the verb. The adjective *hosijar* ‘intelligent’, for example, does not show any overt number or gender agreement regardless of the features of the noun it modifies.

A.4.3 Demonstrative and Pronouns

The pronominal/demonstrative system varies across the Marwar region. In this discussion, I focus on the varieties of Marwari spoken in and around

		Singular		Plural
		Masc.	Fem.	Masc./Fem.
1st	EXCL		<i>mẽ</i>	<i>mẽ</i>
	INCL			<i>apã</i>
2nd	FAM		<i>tu</i>	<i>t^he</i>
	HON		<i>t^he</i>	<i>t^he</i>
3rd	PROX	<i>o</i>	<i>a</i>	<i>e</i>
	DIST	<i>bo/vo</i>	<i>ba/va</i>	<i>be/ve</i>

Table A.7: Marwari pronouns and demonstratives

Jodhpur city including Jodhpuri Marwari, KM Marwari, and Osian Marwari.

The full paradigm of Jodhpur Marwari pronouns and demonstrative pronouns is shown in Table A.4.3 below.²

Only the third person demonstratives show masculine/feminine agreement, but all pronominals and demonstratives trigger gender agreement on the verb.

Unlike Hindi, Marwari has both an inclusive and an exclusive first person plural pronoun. The exclusive third person plural pronoun *mẽ* is homophonous with the singular first person pronoun. Some speakers also use *mẽ sãb* ‘we all’ for the first person plural.

There are two second person pronouns in Marwari: the familiar (*tu*) and the honorific (*t^he*). Both the singular and the plural honorific take the same form as the plural, second person familiar. The honorific form is used to address elders or people who the speaker does not know well, while the familiar second person pronoun is used when addressing people the speaker is close to, children, or people with lower status.

Like Hindi, the Marwari third person pronoun is actually a bare demonstrative. Where the Hindi demonstrative shows only number agreement, the singular demonstrative in Marwari has both number and gender. The plural demonstratives show only number.

While demonstrative pronouns can be used as pronouns, these are really

2. Several of the Marwari speakers who I worked with spelled both the singular and the plural first person pronoun as मैं in Devanagari, which would normally be pronounced /m^he/. All of them agreed, though, that there is no aspiration on the nasal consonant and both the singular and plural first person pronouns are pronounced *mẽ*. Magier (1983) also gives the Marwari first person plural pronoun as *m^he*, where the aspiration of the nasal consonant marks plurality.

bare demonstratives. They may also take an NP complement, as shown in (49).

- (49) a. *o/bo* *t̂oro* *futro* *ʔe*
 this/that.M.SG boy.M.SG beautiful.M.SG be.PRS.3.SG
 `This/that boy is beautiful.'
- b. *a/ba* *t̂ori* *futri* *ʔe*
 this/that.F.SG girl.F.SG beautiful.F.SG be.PRS.3.SG
 `This/that girl is beautiful.'

Where the DemP is plural, the demonstrative does not show any overt gender marking but any adjectives and verbs will still show person, number, and gender agreement.

- (50) a. *e/be* *t̂ora* *futra* *ʔe*
 these/those boy.M.SG beautiful.M.PL be.PRS.3.PL
 `These/those boys are handsome.'
- b. *e/be* *t̂ori* *futri* *ʔe*
 these/those girls.F.PL beautiful.F.PL be.PRS.F.PL
 `These/those girls are beautiful.'

Marwari pronouns have an irregular oblique form when they are case marked or inside of a postpositional phrase. This will be discussed further in Section A.5.

A.5 Postpositional Phrases

Adpositional phrases in Marwari follow the noun phrase and are properly known as postpositions. Postpositions also trigger oblique case on nouns, adjectives, and other postpositions which are inside of the postpositional phrase. Examples of simple postpositions, made up only of one word, include *t^haji* ‘up to, until’ and *mat^he* ‘on’.

- (51) a. *kale* *tʰaji*
tomorrow.OBL until
`until tomorrow'
- b. *ma-ra* *ḍʒənəm* *ḍin* *matʰe*
I.SG.OBL-of.M.SG.OBL birth day.M.SG.OBL on
`on my birthday'

Case marking in Marwari is done through postpositions. These will be discussed further in Section A.5.1.

It is possible to embed a postpositional phrase (PP) inside of another PP, as illustrated in (52).

- (52) *bat* *re* *biṭf* *mẽ*
story/conversation.M.SG.OBL of.M.SG.OBL middle.OBL in
`in the middle of the story'

Postpositions trigger oblique case marking or the oblique form of the noun phrase. See Section A.4 for a discussion of the oblique forms of nouns and adjectives.

A.5.1 Postpositional Case Marking

It is typical for MIA languages to use postpositional case marking, and this is true for Marwari, as well. Table A.8 gives a list of the different types of case marking found in Marwari and an example of each. Note that many of the case marking postpositions can mark different types of case depending on position and usage.

Ergative, accusative, and dative case marking are discussed in more depth below.

A.5.1.1 Ergative Case Marking and agreement

Many Indo-Aryan languages have a split ergative system in which most sentences employ a nominative-accusative case system but the subject of transitive, perfective sentences takes ergative case marking. This second case marking system is really an ergative-accusative system as the object can still take accusative case marking. Importantly, where an argument is case marked,

Postposition	Case
∅	Ergative
<i>ne</i>	Accusative
<i>ne</i>	Dative Subject
<i>ne</i>	Dative (Indirect Object)
<i>ũ</i>	Instrumental
<i>ũ</i>	Comitative
<i>ũ</i>	Ablative/Source
<i>ro</i>	Genitive

Table A.8: Prepositional case markers in Marwari.

agreement with the verb is blocked. If all arguments are case marked, then the verb takes the default, masculine singular, agreement.

Marwari does not have any overt ergative case marking. Yet, agreement with the subject is still blocked when the predicate is transitive and perfective. In (53), for instance, both the subject and the recipient are feminine singular, yet the verb agrees with the (masculine singular) object *kek* ‘cake’.

- (53) *gita anu re vaste kek bəŋaijo*
 Gita Anu for cake.M.SG make.PFV.M.SG

‘Gita made a cake for Anu.’

Similarly, in (54) agreement with the masculine, singular subject *rəvi* ‘Ravi’ is blocked. Instead, the verb agrees with the singular feminine object *sima ri tʰatri* ‘Sima’s umbrella’.

- (54) *rəvi sima ri tʰatri leni*
 Ravi Sima of.F.SG umbrella.F.SG take.PFV.F.SG

‘Ravi took Sima's umbrella.’

Because agreement with the subject is blocked even when it is not overtly case marked, I assume that there is a covert or null ergative case marker which appears on the subject. Note that this is not implicit case as implicit case does not block verbal agreement.³

3. See Bhatt (2011) for a similar analysis of Katchi.

Ergative case marking applies only when the predicate is both perfective and transitive. In (55a), the verb *pərnid̥ʒi* ‘to be married’ in (55a) is perfective, but it is intransitive. The subject, therefore, does not receive any covert ergative case marking and may agree with the verb.

- (55) a. *mẽ donũ do b^haija ã pərnid̥ʒi*
 we both two brother.M.PL with be.married.PFV.F.PL
 ‘We both married two brothers.’
- b. *mẽ donũ do b^haija ã bijao kərijo*
 we both two brother.M.PL ACC wedding.M.SG do.PFV.M.SG
 ‘We both married two brothers.’

In (55b), on the other hand, the verb *kər-* ‘do’ is transitive and can no longer agree with the subject. The verb, therefore, can only agree with *bijao* ‘wedding’.⁴ Even though the subject of 55b is not overtly case marked, agreement with the verb is blocked.

A.5.1.2 Differential object marking: Accusative Case

In Marwari, the object of a transitive sentence takes accusative case in some situations. As Magier (1983, pg. 89) explains, ‘[accusative case’s] presence or absence is determined by semantic parameters of specificity and definiteness... saliency determines the presence versus absence of ne marking on direct objects, and the components of saliency include specificity and definiteness, as well as animacy and humanness’ (*emphasis his*). This is known as *differential object marking*, which simply means that some objects take accusative case while others do not.

In nearly all cases, a human object will take accusative case, as illustrated in (56).

- (56) *marsab tabər ne ek tofo dijo*
 teacher.M.SG child.SG.OBL ACC one gift.M.SG give.M.SG
 ‘The teacher gave a student a gift.’

4. In the example (55b), *kər-* cannot agree with *do b^haija* ‘two brothers’ because agreement is blocked by *ã*. The postposition *ã* here can either be considered an accusative case marker or as a comitative case marker, depending on the analysis. Either way, it blocks agreement with the verb.

Inanimate objects may be accusative case marked, as well, as in (57). Generally, an inanimate object will be case marked if it has a definite interpretation.

- (57) *tʰe dəqʰi ne dʰjan ũ dekʰoʎa*
 you.HON ball.F.SG ACC attention with look.FUT.M.SG
 'You will watch the ball attentively.'

A.5.1.3 Dative Case Marking: Indirect Object

The indirect object of a ditransitive verb receives dative case marking. The dative case marker, *ne*, is homophonous with the accusative case marker and also appears on the dative subject. (58) and (59) are examples of dative case marking on the indirect object.

- (58) *mʰẽ ram ne mʰa-ri potʰi de di*
 I Raam DAT I.OBL-of.F.SG book.F.SG give give.LGT.PFV.F.SG
 'I gave my book to Raam.' (from Magier 1983, pg. 87)

- (59) *mʰẽ ram ne lapsi d̂zimai*
 I Raam DAT wheat-gruel feed.PFV.F.SG
 'I fed wheat gruel to Raam.' (from Magier 1983, pg. 87)

A.5.1.4 Dative Case Marking: Dative Subject

In Marwari, like Hindi, certain verbs trigger dative case marking on the subject. These verbs or verb phrases are often called experiencer verbs, and the subject of these types of sentences may be called the dative subject. There are a large number of experiences verbs in Marwari, reflecting a wide range of experiences, and what verbs will trigger dative case marking on the subject are not always predictable (Magier 1983).

Example (58) is an example of dative case marking triggered by the experiential predicate *pasənd ho-* 'to like'.

- (60) *mə-ne a tʰori pasənd he*
 I.OBL-DAT this.F.SG girl.F.SG pleasant be.PRS.3.SG
 'I like this girl.'

Like other types of case marking, dative subject marking blocks agreement with the verb. In (60), for example, the verb cannot agree with the first person subject so it must take default agreement.

Verbs of necessity or desire may also trigger dative case marking (61).

- (61) *va donō ne ek nāvi sari k^haridāṇa*
 they.F.PL both DAT one new.F.SG.OBL sari.F.SG.OBL buy.INF.OBL
ri d̄zarut hε
 of.F.SG necessity.F.SG be.PRS.3.SG

'They both needed a new sari.'

It is the full predicate which triggers dative case, rather than just the verb itself. This can be seen in examples like (59), where the verb *a-* 'come' would not normally require a dative subject.

- (62) *m^ha-ne nīd ave*
 I.OBL-DAT sleep come.IMPV.3.SG

'I feel sleepy.'

A.5.2 Phrasal postpositions

While several postpositions in Marwari are single words, the majority of postpositions are what may be called *phrasal postpositions* or *complex postpositions*. Phrasal postpositions are postpositions which were often formed of two or more words and which continue to be written as several words. These are generally made up of the adposition *re* plus another word which carries the bulk of the meaning.

Phrasal postpositions were historically cases of one postpositional phrase embedded inside of the other, where the second part of the phrasal postposition was either a noun or adjective (Magier 1983). Often these phrases have become grammaticalized and the functional word no longer has its own meaning. One example of this is the phrasal postposition *re kāne* 'near'. *kāne* is the locative form of a noun which used to mean 'vicinity' or 'direction' but is now limited in use (Magier 1983).

- (63) *ma- re kəne*
 I.SG.OBL- near
 `near me'

Because the two (or more) words are acting together to contribute one meaning, I have chosen to gloss these as if they were a single word even though they are written and pronounced as a phrase.

In some cases, the noun embedded inside of the phrasal postposition has not been entirely grammaticalized but retains its own semantic contribution. Even though these might technically be considered cases of PPs embedded inside of other PPs, I consider them phrasal postpositions alongside the more fully grammaticalized phrases.

There are several phrasal postpositions in Marwari where the genitive case marker *re* is optional. An example of this is *(re) maj* ‘in’.

- (64) *ma-ri tḍʒori (re) māi*
 1.SG-of.F.SG.OBL lockbox in
 `in my lockbox'

Other phrasal postpositions require both *re* and the content word. An example of this is *re hat^he* ‘with, accompanied by’, which can never be pronounced as simply *hat^he*.

- (65) *do t̄forijā *(re) hat^he*
 two girls with
 `with two girls'

A.5.3 Possession in Marwari

One of the features of the South Asian linguistic area is the lack of a verb to show possession. Instead, Marwari uses two different postpositions to make possession, and these may roughly be distinguished as marking alienable or inalienable possession.

The postposition *ro* ‘of’ generally marks inalienable possession such as family members or property. Unlike other postpositional phrases in Marwari, *ro* takes two arguments, the possessor and the possessed, where the owner precedes *ro* and that which is owned follows it.

(66) [DP [PP [DP *ram*] *ro*] *g^har*]
 Raam of house
 `Raam's house' or `the house of Raam'

(67) *m^ha-ri* *ek* *beḷi* *he*
 I.OBL-of.F.SG one daughter.F.SG be.PRS.3.SG
 `I have one daughter.'
Lit.: `My one daughter exists.' (from Magier 1983, pg. 86)

ro agrees with the possessed object in number and agreement, as seen in (68a) and (68b).

(68) a. *viḷay* *ro* *bəsto*
 Vijay.M.S of.M.SG backpack.M.SG
 `Vijay's backpack'
 b. *renu* *ra* *bəsta*
 Renu.F.S of.M.PL backpack
 `Renu's backpacks'

The phrasal postposition *re kəne* `near' can loosely be thought of as marking alienable possession. *re kəne*, or simply *kəne* as it is used by some speakers, follows the possessor and does not show any kind of agreement. While (69) literally means `there is an umbrella near Sita', this has been grammaticalized to mean that Sita possesses an umbrella.

(69) *nifa* (*re*) *kəne* *t^hatri* *hi*
 Nisha near umbrella.F.SG be.PRS.F.SG
 `Nisha has an umbrella.'

The postposition *re kəne* takes a single argument, the possessor, and the possessive phrase may be separated from the possessee, as (70) shows.

(70) *uŋ kəne gəŋa ʃem ũ ek*
 that.SG.OBL near much.M.SG.OBL time.M.SG from one

'Bullet' ho

'Bullet' be.PRS.M.SG

'He had an (Enfield) Bullet for a long time (where a Bullet is a type of motorcycle).' [KM MAR.]

(*re*) *kəne* can only appear in a copula construction. In other cases, *ro* will be used to mark possession even when the possessee is not inalienable.

A.6 The Marwari Verb Phrase

It is common in MIA languages for both aspect and tense to be encoded separately. Aspect is encoded either as a suffix on the verb root or, in the case of the progressive, as an auxiliary immediately following the verb root. Tense marking is derived from the past, present, and future copula and is most commonly an auxiliary. The only exception to this is the present imperfective verb phrase which encodes both tense and aspect along with the appropriate agreement within a single suffix affixed to the verb root.

Like many MIA languages, Marwari agreement encodes either gender and number or person and number. As Magier (1983) notes, the encoding of gender, number, and person do not co-occur together. Within the verb phrase, generally number and gender is coded in the aspect phrase person and number is encoded as part of the tense auxiliary.

A.6.1 Tense

The tense marking in Marwari is derived from the past, present, and future forms of the copula. In verb phrases which have aspect, the tense auxiliary (which has the same form as the copula) follows the aspect-marked verb. For this reason, I have glossed the bare copula without a verb phrase as 'be' and the past or present tense marker. In (71a), the past tense form of the copula, *tʰi*, is part of the verb phrase *bəŋəiʃi tʰi* 'made'. (71b) shows an example of *he*, the present tense form of the copula 'to be', being used as a present tense copula meaning 'is'.

- (71) a. *gita kale anu re vaste kek bəŋāiji tʰi*
 Gita yesterday Anu for cake.M.SG make.PFV.F.SG PST.F.SG
 ‘Gita made a cake for Anu yesterday.’
- b. *bo tʰoro futro he*
 that.M.SG boy.M.SG handsome.M.SG be.PRS.3
 ‘That boy is handsome.’

A.6.1.1 Present tense and the present tense copula

Marwari uses the present tense copula as a present tense auxiliary, as well. The present tense copula shows both person and number agreement but does not show gender agreement.⁵

	Singular	Plural
1st INCL	<i>hũ</i>	<i>ha</i>
EXCL		<i>ha</i>
2nd FAM	<i>he/?ε</i>	<i>ho</i>
HON	<i>ho</i>	<i>ho</i>
3rd	<i>he/?ε</i>	<i>he/?ε</i>

Table A.9: Present tense copula/auxiliary

The variation between the phonemes /h/ and /ʔ/ in Marwari can be seen in the pronunciation of the present tense copula.

A.6.1.2 Past tense & the past copula

Past tense marking in Marwari only shows gender agreement and partial number agreement. The third person masculine singular and masculine plural show number marking, and the second person familiar is marked for number. All first person, 2nd person honorific, and all feminine agreement lack number agreement. Thus, the past tense copula and past tense auxiliary are the same

5. Magier (1983) gives the first person plural inclusive form of the copula as *hã*, in which the vowel is nasalized. The consultants that I worked with did not nasalize *ha* nor did they mark it as nasal when spelling it in Devanagari. Plural agreement in Hindi is often nasalized, though, so it is likely that this is a matter of variation and that there are varieties of Marwari which nasalize the plural form.

regardless of person except for the singular second person honorific, which takes the same form as the plural.

	Singular		Plural	
	Masc.	Fem.	Masc.	Fem.
1st, 2nd.FAM, 3rd	<i>ho</i>	<i>hi</i>	<i>ha</i>	<i>hi</i>
2nd.HON	<i>ha</i>	<i>hi</i>	<i>ha</i>	<i>hi</i>

Table A.10: Past tense copula/auxiliary

A.6.1.3 Future tense

In the future tense copula, agreement does not seem to affect the ending but seems to change the vowel in the middle of the copula (see Table A.11). The Hindi future tense copula is made up of the subjunctive form of the verb plus a future tense marker. I propose that the same is happening in Marwari, as well: the future tense copula involves the subjunctive tense plus a future modal marker *la*. Unlike Hindi, the future tense marker does not show any agreement and is the same regardless of person, number, or gender. (For some speakers, *la* may alternatively be pronounced as *[a]*.)

	Singular	Plural
	Masc./Fem.	Masc./Fem.
1st INCL	<i>ũla</i>	<i>v^hela/v^hala</i>
EXCL		<i>v^hala</i>
2nd FAM	<i>v^hela</i>	<i>v^hola</i>
HON	<i>v^hola</i>	<i>v^hola</i>
3rd	<i>v^hela</i>	<i>v^hela</i>

Table A.11: The future tense copula

A.6.2 Aspect

Aspect in Marwari is marked independently from tense.⁶ Generally, the aspect marking occurs directly in the verb root and tense is expressed through a separate auxiliary

6. Because the imperative and inchoative aspects do not appear in the data presented in this dissertation, they are not included in this discussion.

The aspectual marking on the verb generally agrees with the appropriate argument in number and gender while the tense auxiliary will reflect person and number.

A.6.2.1 Perfective aspect

Marwari has a split ergative case system in which the most sentences will take nominative-accusative case marking but the subject of transitive, perfective sentence will have a covert ergative case marking which blocks agreement with the verb. In these cases, the predicate will agree with the object, indirect object, or take default masculine singular agreement (in that order). Otherwise, the predicate agrees with the subject.

The perfective aspect forms as shown in Table A.12.

	Singular		Plural	
	Masc.	Fem.	Masc.	Fem.
1st, 2nd.FAM, 3rd	<i>k^hajo</i>	<i>k^haji</i>	<i>k^haja</i>	<i>k^haji</i>
2nd.HON	<i>k^haja</i>	<i>k^haji</i>	<i>k^haja</i>	<i>k^haji</i>

Table A.12: Perfective aspect of *kha-* ‘eat’

For some speakers, if the verb root ends in a consonant, the perfective marking will be *-o/-a/-i* for masculine singular, masculine plural, and feminine respectively. For other speakers, if the verb root ends in a consonant, the endings are *-ijo/-ija/-i*.

A.6.2.2 Imperfective aspect

In most cases, the aspect and tense marking in Marwari are separate, with aspect being marked on the verb and tense indicated through a following tense auxiliary. The exception to this is the present imperfective which is expressed through a single ending, as shown in Table A.13.⁷

For the third person, the present imperfective marking on the verb is generally *-e* as long as the verb root ends in a consonant. When the verb ends in a vowel, the phoneme */v/* is inserted between the verb root and the third person tense/aspect marking. In these case, the tense/aspect marking is *-ve*.

7. Osian Marwari speakers occasionally used the standing imperfective aspect marking with a tense auxiliary, even in present tense.

	Singular	Plural
	Masc./Fem.	Masc./Fem.
1st	<i>karũ</i>	<i>kara</i>
2nd FAM	<i>kare</i>	<i>karo</i>
2nd HON	<i>karo</i>	<i>karo</i>
3rd	<i>kare</i>	<i>kare</i>

Table A.13: Present imperfective *kar-* ‘do’

If the predicate is in past or future tense, the imperfective aspect is marked directly on the verb and tense is expressed through an auxiliary, just as it is in all of the other cases. Table A.14 shows the verb endings for imperfective aspect in all but present tense.

	Singular		Plural	
	Masc.	Fem.	Masc.	Fem.
1st, 2nd.FAM, 3rd	<i>r̥amto</i>	<i>r̥amti</i>	<i>r̥amta</i>	<i>r̥amti</i>
2nd.HON	<i>r̥amta</i>	<i>r̥amti</i>	<i>r̥amta</i>	<i>r̥amti</i>

Table A.14: Imperfective Aspect with *r̥am-* ‘play’

A.6.2.3 Progressive aspect

Marwari does have a dedicated progressive aspect, but most commonly, imperfective aspect is used for both habitual and progressive events. Even when translating Hindi sentences which used the progressive aspect, in most cases, Marwari speakers employed imperfective instead.

Progressive aspect in Marwari is expressed through an auxiliary or separate word following the verb root.

	Singular		Plural	
	Masc.	Fem.	Masc.	Fem.
1st, 2nd.FAM, 3rd	<i>rijo</i>	<i>ri</i>	<i>rija</i>	<i>ri</i>
2nd.HON	<i>rija</i>	<i>ri</i>	<i>rija</i>	<i>ri</i>

Table A.15: Progressive aspect auxiliary

A.6.3 Light Verbs

One of the features of South Asian languages is the availability of the light verb constructions. Light verbs, otherwise known as explicator verbs, compound verbs, or complex predicates, are verb forms which follow the main verb and which contribute something to the verb phrase as a whole without making their own distinct semantic contribution. For example, *deve* in (72), which would normally be interpreted as ‘give.IMPFV.3’ does not contribute the full meaning of ‘give’ but gives a sense that the action contributed by the primary verb (in this case, *t̃for* ‘leave’) is for the benefit of someone other than the subject.

- (72) *kisən rod̃zina hēṅ gaya ne t̃for*
 Kishan daily every cow.OBL.M.PL ACC leave
deve he
 give.LGT.IMPFV.3 PRS.3.SG

‘Kishan leaves the cows (there) every day.’

Verbs which can occur as light verbs in Marwari include *deṅo* ‘to give’, *leṅo* ‘to take’, *d̃zaṅo* ‘to go’, and *pəṛṅo* ‘to fall’.

Light verbs may occur in a variety of aspect phrases including imperfective (72), perfective (73)⁸, and future tense (74).

- (73) *nifa mər d̃zavela*
 Nisha hit/die go.LGT.FUT.3.SG

‘Nisha will die.’

- (74) *nifa k^haṅo k^ha lijo*
 Nisha food.M.SG eat take.PFV.M.SG

‘Nisha ate all of the food.’

Light verbs and highly grammaticalized, so much so that speakers often consider the light verb to be part of the same word as the verb.

8. The verb root *mər-* literally means ‘hit’, but the verb phrase *mər d̃za-* ‘hit go.LGT’ has been grammaticalized to mean ‘die’.

A.7 Adverbs and adverbial PPs

There are very few ‘true’ adverbials in Marwari. Most adverbs and adverbial phrases are actually postpositional phrases. The most common of these are the time adverbials such as *aṇe* ‘now’ and *hames* ‘always’. Other true adverbs include *haṭke* ‘quickly’ and *ekardam* ‘suddenly’.

Adverbial postpositional phrases are far more common than simple adverbs. These are made up of a noun phrase followed by the postposition *ũ* ‘-ly’, as shown in (75).

- (75) a. *laq ũ*
love with
‘with love, lovingly’
- b. *rād̥zi ũ*
happiness with
‘happily’

A.8 Negation

Marwari varieties differ in what word they use for negation. Khariya Mithapur Marwari and Jodhpur Marwari will use both *koni* and *ni* to mark sentential negation. Osian Marwari only used *ni* to mark negation.

- (76) *ba ni d̥zave*
that.F.SG NEG go.IMPV.3.SG

‘She doesn’t go.’

- (77) *ba fuṛi koni he*
that.F.SG beautiful.F.SG NEG be.PRS.3.SG

‘She is not beautiful.’

Like other MIA languages, Marwari uses a separate morpheme for the prohibitive. The prohibitive *mət:i* may be translated as something like ‘don’t’.

- (78) *skul mət:i ãʒa*
school PROH go.IMP
'Don't go to school.'

A.9 Final Remarks

Despite its large number of speakers, Marwari is a less documented language which has received very little attention. One resource which I found particularly helpful throughout this research (and one of the few formal treatments of Marwari) was David S. Magier's (1983) PhD Dissertation, *Topics in the Grammar of Marwari*. While his dissertation is largely focussed on the tense and aspect system of Marwari, he also includes a useful discussion of older grammars and descriptions of Marwari and why many of these are less useful in a formal context.

Lakhan Gusain (2004) has also written a short Marwari grammar titled, simply, *Marwari*. The Marwari he describes is rather different from the varieties I investigated, though, and is probably a different variety from that spoken in Jodhpur.

Appendix B

Testing for binding effects: stories with Plausible Dissent

B.1 Introduction

This is a selected collection of Marwari stories developed to test binding effects using the plausible dissent method described in Chapter 8. All of these stories were originally written in Hindi and translated to Marwari with the help of Marwari consultants. The sentences tested along with the response is included after each story or, in the case of *Jyoti's Flowers* (Section B.5), in the story where they were first asked. The variety of Marwari represented is indicated for each story.

This is just a representative example of the stories which were tested. Many of these stories were also tested in Hindi, but I have chosen to include the Marwari stories here as I feel these will be more interesting.

The intended response is given following the free translation of each true-false test question.

B.2 Geeta and Sita bake a cake

This story was used to test binding effects in postnominal relative clauses and extraposed postnominal relative clauses. The story itself is written in the Jodhpuri and Khariya Mithapur variety of Marwari.

- (1) *ma-re gaõ maj do iʰorijã he d̂ziko gəŋo*
 I.OBL-of.OBL village.OBL in two girl.F.PL be.PRS.3.PL which very.M.SG
bədiʝa kʰaŋo bəŋave
 great food.M.SG make.IMPV.PRS.3.SG

'In my village, there are two girls who make very good food.'

- (2) *gita apre d̂zəŋəm dɪn vaste ek kek bəŋajo*
 Gita own.OBL birth day for one cake.M.SG make.PFV.M.SG

'Gita made a cake for her (own) birthday.'

- (3) *gita o kek rad̂zi man ã kʰajo*
 Gita this.M.SG cake.M.SG happy.OBL.F.SG heart.OBL with eat.PFV.M.SG

'Gita ate that cake with a happy heart.'

- (4) *sita apre d̂zəŋəm dɪn vaste ek kek bəŋajo*
 Sita own.OBL birth day for one cake.M.SG make.PFV.M.SG

'Sita made a cake for her (own) birthday.'

- (5) *sita apro kek rad̂zi man ã kʰajo*
 Sita own.M.SG cake.M.SG happy.OBL.F.SG heart.OBL with eat.PFV.M.SG

'Sita ate her (own) cake with a happy heart.'

True or false (*sətʃi ja d̂zʰut*):

- (a) *va o kek d̂zəko gita apre vaste*
 that.F.SG this.M.SG cake.M.SG which Geeta own.OBL for
bəŋajo kʰajo
 make.PFV.M.SG eat.PFV.M.SG

'She ate this cake which Geeta made for herself.' [*d̂zʰut* / FALSE]

- (b) *sita rəḍʒi mən ã apro kek*
 Sita happy.OBL.F.SG heart.OBL.F.SG with own.M.SG cake.M.SG
kʰajo
 eat.PFV.M.SG

‘Sita ate her (own) cake with a happy heart.’ [*sətʃi* / TRUE]

- (c) *va o kek kʰajo ḍʒəko gita apre vaste*
 that.F.SG this.M.SG cake.M.SG eat.PFV.M.SG which Geeta own.OBL for
bəŋajo
 make.PFV.M.SG

‘She ate this cake which Geeta made for herself.’ [*ḍʒʰut* / FALSE]

B.3 Neha and Sima buy new saris

This story was primarily developed to test binding effects in extraposed temporal clauses. This story was also originally written in Hindi and then translated to Marwari. The variety represented here is Jodhpuri and Khariya Mithapur Marwari.

- (1) *neha ər sima ne ek gəŋa moʒa bijao mē*
 Neha and Sima DAT one very.OBL.M.SG big.OBL.M.SG wedding.F.SG in
bulaja
 call.PFV.M.PL

‘Neha and Sima were invited to a very big wedding.’

- (2) *va donũ ne nəvi fənsi sari kʰərida-ŋa*
 those.OBL.F.PL both DAT new.F fancy.F.SG sari.F.SG buy-INF.OBL.M.SG
ri ḍʒərut he
 of.F necessity.F.SG be.PRS.3

‘They both needed to buy a fancy new sari.’

- (3) *neha kijo t^{hu} mari mənpasənd*
 Neha say.PFV.M.SG you.FAM my.OBL.F.SG favorite.OBL.F.SG
dukan mat^{he} aje
 store.OBL.F.SG on come.IMP.HON

'Neha said: You should come to my favorite store.'

- (4) *mē hames mari sari u^the ù k^haridu*
 I always my.F.SG sari.F.SG there from buy.SUBJ.1.SG

'I always buy my saris from there.'

- (5) *pəŋ sima kijo ni mə-ne d̪ʒod^hpur maj ek neni dukan*
 but Sima say.PFV.M.SG no I.DAT Jodhpur in one small.F.SG store.F.SG
gəŋi pasənd he
 very.F.SG liking be.PRS.3.SG

'But Sima said: No. There is a small store in Jodhpur that I really like.'

- (6) *mē hames mari fənsi sari u^the ù k^haridi*
 I always my.F.SG fancy.F.SG sari.F.SG there from buy.SUBJ.1.SG

'I always buy my fancy saris there.'

- (7) *ə ve don̄ bijao ro k^hub əŋəd*
 and those.PL both wedding.OBL.F.SG of.M.SG beautiful enjoyment
lijo
 take.LGT.PFV.M.SG

'And they both enjoyed the beautiful wedding.'

True or false (*sət̪fi ja d̪ʒ^hut*):

- (a) *neha ə sima don̄ ek nəvi sari k^harida-ŋa ri*
 Neha and Sima both one new.F.SG sari.F.SG buy-INF.F.SG necessity
d̪ʒərut he
 be.PRS.3.SG

'Neha and Sima both needed to buy a new sari.' [*sət̪fi* / TRUE]

- (b) *va apri navi sari un dukan ã*
 that.F.SG own.F.SG new.F.SG sari.F.SG that.OBL store.OBL.F.SG from
k^harid^hi [d̪ʒət^he ã neha hames sari k^haride]
 buy.PFV.F.SG where from Neha always sari.F.PL buy.IMPV.3.SG
 ‘She bought her sari from where Neha always buys saris.’ [d̪ʒ^hut / FALSE]

B.4 Two Arrogant Boys

This story was primarily developed in order to test binding effects in nominal correlatives but also included target sentences with temporal correlatives which did not have a demonstrative. The story itself was translated with two Osian speakers and rechecked with speakers from Sarechan and Jodhpur. The version of the story I have given here is from the Osian variety.

- (1) *ek gāv mē do t̪^hora dost ha*
 one village.OBL.M.SG in two boy.M.PL friend be.PST.M.PL

‘In one village, two boys were friends.’

- (2) *be ašif ar višal ha*
 those Aashish and Vishal be.PST.M.PL

‘They were Aashish and Vishal.’

- (3) *ve t̪^hora ləgpəti ʔa ar be gəṇa kə[ə]dɔŋ a|a*
 those boy.M.PL rich PST.M.PL and those very arrogant one.M.PL
ha
 be.PST.M.PL

‘Those boys were rich and they were very arrogant.’

- (4) *un donō ne sirəf gəṇi fuṭri t̪^horija d̪ʒike*
 those.OBL both DAT only very.F.PL beautiful.F.PL girl.F.PL which
re kəne gəṇa həla ripija he daji he
 near very.M.PL full.M.PL be.PRS.3.SG liking be.PRS.3.SG

‘They both only like beautiful girls who have a lot of money.’

- (5) *ek tʃʰoro aʃif ho*
 one boy.M.SG Aashish be.PST.M.SG
 `One boy was Aashish.'
- (6) *aʃif ləmbo ər fuʃro ho*
 Aashish tall.M.SG and handsome.M.SG be.PST.M.SG
 `Aashish was very tall and handsome.'
- (7) *un-re kəne mɛŋgi gaʃi hi ər bo*
 that.OBL-near expensive.F.SG car.F.SG be.PST.F.SG and one
ek mote gʰər mɛ rəveto
 large.OBL.M.SG house in live.IMPV.PST.M.SG
 `He owned a very expensive car and he lived in a big house.'
- (8) *ek tʃʰori ne aʃif gəŋo daji ʔo*
 one girl.OBL.F.SG DAT Aashish very.M.SG liking be.PST.M.SG
 `One girl loved Aashish very much.'
- (9) *un-na nam bʰomli ho*
 that.OBL-of.M name Bhomlii be.PST.M.SG
 `Her name was Bhomlii.'
- (10) *ek dɪn bʰomli aʃif ne kajo mɛ tʰa ũ pərem*
 one day Bhomlii Aashish ACC say.PFV.M.SG I you.OBL SRC love
karũ
 do.SUBJ.1.SG
 `One day, Bhomlii told Aashish: I am in love with you.'
- (11) *aʃif bʰomli matʰe gəŋo həsijo*
 Aashish Bhomlii on very.M.SG laugh.PFV.M.SG
 `Aashish laughed very hard at Bhomlii.'

- (12) *vifal tʃʰup-tʃʰap rijo həsijo koni*
 Vishal quiet-REDUP PROG.M.SG laugh.PFV.M.SG NEG
 `Vishal kept quiet and didn't laugh.'
- (13) *afif kajo tũ geli ʔe*
 Aashish say.PFV.M.SG you.FAM crazy.F.SG be.PRS.3.SG
 `Aashish said: You are crazy.'
- (14) *tũ ma-ne kikər daji a fəke*
 you.FAM I.OBL-DAT how_Q liking come able.SUBJ.3.SG
 `How could I ever love you?'
- (15) *vifal bʰomli matʰe ni həsijo pəŋə mət hi*
 Vishal Bhomlii on NEG laugh.PFV.M.SG but do-not EMPH
hotʃʰo ke bo həkro ho
 think.SUBJ.2.FAM COMP that.M.SG good.M.SG be.PRS.M.SG
 `Vishal didn't laugh at Bhomlii, but don't think that he is a nice person.'
- (16) *ek tʃʰori mina ne vifal gəŋo hakro lage*
 one girl.F.SG Meena DAT Vishal very.M.SG good feel.IMPFV.PST.3.SG
 `One girl, Meena, liked Vishal a lot.'
- (17) *ek dn mina vifal ne kajo mē tʰa (re) ũ pərem*
 one day Meena Vishal ACC say.M.SG I you.HON SRC love
karũ
 do.SUBJ.1.SG
 `One day, Meena said to Vishal: I am in love with you.'
- (18) *ekdəm vifal dʒor ũ həsijo*
 suddenly Vishal loud with laugh.PFV.M.SG
 `Suddenly Vishal laughed loudly.'

- (19) *m tem d̄ʒəd vɪʃəl həs rɪʒo ho aʃɪf*
 this.OBL time when Vishal laugh PROG.M.SG be.PST.M.SG Aashish
tʃʰʊp ho
 quiet be.PST.M.SG

'This time, when Vishal was laughing, Aashish was quiet.'

- (20) *vɪʃəl mɪna ne kəʒo ho are! tu mə-ne kɪkər*
 Vishal Meena ACC say.M.SG PST.M.SG INTJ you.FAM I.OBL-DAT how
dəʒɪ a fəkə
 liking come able.SUBJ.3.SG

'Vishal said to Meeta: Oi! How could I ever like you?'

- (21) *ər doɪ tʃʰorɪʒa ut:a ʊ ro-ən² nah gi*
 and both girl.F.PL there.OBL from cry-and run-away go.PFV.F.PL

'And both girls ran away from there crying.'

True or false (*sətʃɪ ja d̄ʒʰut*):

- (a) *d̄ʒəd bʰomli ne aʃɪf dəʒɪ he aʃɪf un-ne*
 when Bhomli DAT Aashish liking be.PRS.3.SG Aashish that.OBL-ACC
nəkər dɪʒo
 reject give.PFV.M.SG

'When Bhomli liked Aashish, Aashish rejected her.' [*sətʃɪ* / TRUE]

- (b) *aʃɪf tʰəkəri ho*
 Aashish poor.M.SG be.PST.M.SG

'Aashish was poor.' [*d̄ʒʰut* / FALSE]

2. The suffix *-ən* acts as a conjunctive participle like *kər*. The conjunctive participle does not have an exact translation in English, but is interpreted as part of a series of events with the same tense and aspect as the matrix verb.

- (c) *mina ne vifal daji ni he*
 Meena DAT Vishal liking NEG be.PRS.3.SG
 'Meena didn't love Vishal.' [$\widehat{d\bar{z}^hut}$ / FALSE]
- (d) *vifal ər afif bəqija tʃʰora ha*
 Vishal and Aashish great boy.M.PL be.PST.M.PL
 'Vishal and Aashish were great boys.' [$\widehat{d\bar{z}^hut}$ / FALSE]
- (e) $\widehat{d\bar{z}iki}$ $\widehat{tʃʰori}$ *ne afif daji he bo un*
 which girl.OBL.F.SG DAT Aashish liking be.PRS.3.SG that.M.SG that.OBL
matʰe həsijo
 on laugh.PFV.M.SG
 'He laughed at the girl who liked Aashish.'
Lit.: 'Which girl liked Ashish, he laughed at her.' [$\widehat{sətʃi}$ / TRUE]
- (f) $\widehat{d\bar{z}əd}$ *bʰomli kajo ke un-ne afif daji*
 when Bhomlii say.PFV.M.SG COMP that.OBL-DAT Aashish liking
he bo un matʰe həsijo
 be.PRS.3.SG that.M.SG that.OBL on laugh.PFV.M.SG
 'When Bhomlii said that she loves Aashish, he laughed at her.'
 [$\widehat{d\bar{z}^hut}$ / FALSE]
- (g) $\widehat{d\bar{z}əd}$ *mina kajo ke un-ne bo daji he*
 when meena say.PFV.M.SG COMP that.OBL-DAT Vishal liking be.PRS.3.SG
vifal un matʰe həsijo
 that.M.SG that.OBL on laugh.PFV.M.SG
 'When Meena said that she loves him, Vishal laughed at her.' [$\widehat{sətʃi}$ / TRUE]

B.5 Jyoti's Flowers

The story *Jyoti's Flowers* tests several different constructions within one story arc. During testing, after every 6-10 sentences, one to three Truth Value Judgments were tested. This was partly to ensure that consultants had not forgot-

ten the story as we went along and partly so that having similar constructions tested alongside one another did not affect the test.

This version of the story is from the Khariya Mithpur variety of Marwari but the story itself was tested with speakers from Jodhpur and Sarechan, as well. In this story, the differences between the two varieties are minor.

- (1) *d̂zjoti ne p^hul gəŋa pəsənd kar he*
 Jyoti DAT flowers very.M.PL liking be.PRS.3.SG PRS.3.SG

'Jyoti likes flowers very much very much.'

- (2) *har sal d̂zjoti apre bəgit^he maj gəŋa runk^həra*
 each year Jyoti own.OBL.M.SG garden.OBL.M.SG many M.PL plant.M.PL
ləgave
 attach.IMPFV.PRS.3.SG

'Every year, Jyoti plants many plants in her garden.'

- (3) *d̂zjoti apre bəgit^he ri gəŋi t̂ɔki ave*
 Jyoti own.OBL.M.SG garden.OBL.M.SG of.F.SG very.F.SG good.F.SG care
kave
 do.IMPFV.PRS.3.SG

'Jyoti's took very good care of her garden.'

- (4) *rod̂zina d̂zjoti apra runk^həra ne pani deve*
 daily Jyoti own.OBL.M.PL plant.OBL.M.PL ACC water give.IMPFV.PRS.3.SG
ə r uŋ-mē k^had^h ʔi deve
 and those.OBL-in fertilizer also give.IMPFV.PRS.3.SG

'Daily, Jyoti gives water to her (own) plants and gives fertilizer to them.'

True or false (*sətʃi ja dʒʰut*):

- (a) *dʒjoti apre bəgitʃʰe ri gəŋi tʃɔki aver*
Jyoti own.OBL.M.SG garden.OBL.M.SG of.F.SG very.F.SG good.F.SG care
kave
do.IMPFV.PRS.3.SG

'Jyoti takes very good care of her garden.' [*sətʃi* / TRUE]

- (5) *ufa ər bʰomli dʒjoti ri pəɾosi he*
Usha and Bhomlii Jyoti of.F.SG neighbor.F.PL be.PRS.3.SG

'Usha and Bhomlii are Jyoti's neighbors.'

- (6) *ve neni tʃʰorija aʃi he*
those small.F.PL girl.F.PL naughty be.PRS.sc 3.sg

'They are small girls.'

- (7) *dʒjoti ne ve tʃɔki koni lage*
Jyoti DAT those good.F.PL NEG feel.IMPFV.3.SG

'Jyoti does not like them.'

- (8) *dʒəde-i dʒjoti pʰul ləgave ufa ər bʰomli va*
when-ever Jyoti flower.M.PL attach Usha and Bhomli those.OBL.M.PL
ne dekʰta i toɾ deve
ACC see.TA EMPH tear give.LGT.IMPFV.PRS.3.SG

'Whenever Jyoti planted flowers, Usha and Bhomlii, on seeing them, would pick them.'

- (9) *ḍʒjoti soṭfiʒo ke mē koni tʃaũ ke uʃa ər*
 Jyoti think.PFV.M.SG COMP I NEG want.SUBJ.1.SG COMP Usha and
bʰomli mara bəgiṭʃa maj ave
 Bhomlii I-of.OBL.M.SG garden.OBL.M.SG in come.IMPV.PRS.3.SG

‘Jyoti thought: I don't want Usha and Bhomlii coming into my garden.’

- (10) *be mara pʰul toʒela*
 those my-of.M.SG flower.M.PL tear.FUT.PL

‘They will pick my flowers.’

- (11) *ḍʒjoti aram ũ soṭfiʒo mē uʃa ər bʰomli ne*
 Jyoti care.OBL with think.PFV.M.SG I Usha and Bhomli ACC
bəgiṭʃe re bare kikər rokʰũ
 garden.OBL.M.SG outside how.manner_Q hold.SUBJ.1.SG

‘Jyoti thought carefully: How can I keep Usha and Bhomlii out of my garden?’

- (12) *hã! mē ḍʒaṇũ*
 Yes! I know.SUBJ.1.SG

‘Yes! I know.’

- (13) *mē ek dʒərauŋo munda⁴ bəŋaũla ər mē uŋe bʰit matʰe*
 I one demon-face make.FUT.1.SG and I that.OBL.SG wall on
ləgauʃa
 hang.FUT.1.SG

‘I will make a demon face and I will hang it on that wall.’

- (14) *o uŋa-ne dʒəveʃa ḍʒəde ve uŋe dekʰela*
 that.M.SG those.OBL ACC scare.FUT.M.SG when those that.OBL-ACC

‘That will scare them when they look at it.’

4. It is common in many parts of India to hang a colorful scary face or a demon face made of plaster on the side of one's house to ward away the evil eye.

- (15) *d̂zjoti b^{hit} mat^{he} d̂ɣaʊŋo munda ləgaj dijo*
 Jyoti wall.OBL on demon-face hang give.LGT.PFV.M.SG
 'Jyoti hung the demon face on the wall.'

True or false (*sət̂fi ja d̂ʒ^{hut}*):

- (b) *d̂zjoti ne b^{homli} ɛr ufa i^fhɔki koni lage kyũke*
 Jyoti DAT Bhomlii and Usha good.F.PL NEG feel.IMPFV.3.SG because
ve a^{li} he
 those naughty be.PRS.3.SG

'Jyoti dislikes Bhomlii and Usha because they are naughty.' [*sət̂fi* / TRUE]

- (c) *ba p^{hul} toɾe d̂ʒəd b^{homli} uŋa-ne*
 that.F.SG flower.M.SG pull.IMPFV.3.SG when Bhomlii those.OBL-ACC
dek^{he}
 see.IMPFV.3.SG

'She picks those flowers when Bhomlii sees them.' [*d̂ʒ^{hut}* / FALSE]

-
- (16) *ek d̂m d̂ʒəde d̂zjoti g^{are} koni hoti ufa ɛr*
 One day when Jyoti house.M.SG.OBL NEG be.IMPFV.F.SG Usha and
b^{homli} uŋe bəg̃i^fhə m̃ə a^{ji}
 Bhomlii that.OBL garden.OBL.M.SG in come.PFV.F.PL

'One day, when Jyoti was not at home, Usha and Bhomii came into that garden.'

- (17) *d̂ʒəde ufa d̂ɣaʊŋo munda ne dek^{hiyo} to uŋe d̂ɣ*
 when Usha demon-face.OBL.M.SG ACC see.PFV.M.SG so that-DAT fear
koni la go
 NEG feel go.LGT.M.SG

'When Usha saw the demon face, she did not feel afraid.'

- (18) *ba həsi*
 that.F.SG laugh.PFV.F.SG
 'She laughed.'
- (19) *təd d̥ʒəde bʰomli uŋe dekʰijo ba i həsi*
 then when Bhomlii that-ACC see.PFV.M.SG that also laugh.PFV.F.SG
 Then, when Bhomlii saw it, she also laughed.'
- (20) *it:a fuʈra pʰul hɛ ufa*
 this-much.M.PL beautiful.M.PL flower.M.PL be.PRS.3.PL Usha
kijo
 say.PFV.M.SG
 'How pretty these flowers are! Usha said.'
- (21) *mē it:a leula d̥ʒita mē rakʰ səkʰũ*
 I this-much.M.PL take.FUT how.much.M.PL I keep able.SUBJ.1.SG
 'I will take how many I can hold.'
- (22) *it:a pjara pʰul hɛ bʰomli*
 this-much.M.PL lovely.M.PL flower.M.PL be.PRS.3.PL Bhomlii
kijo
 say.PFV.M.SG
 'How pretty these flowers are! Bhomlii said.'
- (23) *ər va i levan⁶ lagi d̥ʒit:a va*
 and that.F.SG also LEVAN bring.PFV.F.PL how.many.M.PL that.F.SG
rakʰ səkʰe
 hold able.IMPFV.PRS.3.SG
 'And she also brought as many flowers as she was able to hold.'

6. I am not certain what the translation of *levan* is here.

True or false (*sətʃi ja dʒʰut*):

- (d) *dʒəde ba dərəuŋu munɖa ne dekʰijo to ba*
when that.F.SG demon-face.OBL.M.SG ACC see.PFV.M.SG so that.F.SG
həsi
laugh.PFV.F.SG

'When she saw the demon face, she laughed.' [*sətʃi* / TRUE]

- (e) *dʒjoti sətʃijo ke dərəuŋo munɖo tʃʰorijã ne*
Jyoti think.PFV.M.SG COMP demon-face girl.F.PL ACC
dərvela
scare.FUT.3.SG

'Jyoti thought that the demon face would scare the girls.' [*sətʃi* / TRUE]

-
- (23) *ekardəm tʃʰorija huŋijo ke dʒjoti gʰare*
suddenly girl.F.PL hear.PFV.M.SG COMP Jyoti house.M.SG.OBL-(to)
aegi
come.FUT.F.SG

'Suddenly, the girls heard that Jyoti was coming home.'

- (24) *begi ufa apre gʰare gi ər bʰomli i*
quickly Usha own.OBL house-to go.PFV.F.SG and Bhomlii EMPH
apre gʰare gi
own.OBL house.OBL.M.SG go.PFV.F.SG

'Quickly Usha ran to her house and Bhomlii ran to her own house.'

- (25) *gʰar re maj bʰomli apra pʰul nena ər*
house in Bhomlii own.OBL.M.PL flower.M.PL small.M.SG and
asmana gəmle re maj melija
thin.M.SG vase.OBL.M.SG in put.PFV.M.PL

'Bhomlii put her flowers into a small and thin vase.'

- (26) *ər ufa aprə pʰul ɡol ɡəmlə re maj*
 and Usha own.M.PL flower.M.PL round.OBL.M.SG vase.OBL.M.SG in
melija
 put.PFV.M.PL

'And Usha put her flowers into a round vase.'

- (27) *bʰomli apra pʰul tebəl matʰe rakʰija ər*
 Bhomlii own.M.PL flower.M.PL table.OBL on put.PFV.M.PL and
kijo mē ane rodʒ dekʰ səku
 say.M.SG I now every.day see able.SUBJ.3

'Bhomlii put her flowers on the table and said: now I can see them every day.'

- (28) *ufa apra pʰul bari maj rakʰ*
 Usha own.M.SG flower.M.SG window.OBL.F.SG in keep
dija dʒətʰe ũ ba va-ne
 give.LGT.PFV.M.PL where from that.F.SG that.OBL.M.PL-ACC
hames dekʰ səke
 always see able.SUBJ.3

'Usha put her flowers in the window where she is always able to see them.'

True or false (*sətʃi ja dʒʰut*):

- (f) *ba apra pʰul bʰomli re ɡəmla*
 that.F.SG own.M.PL flower.M.PL Bhomlii of.OBL.M.SG vase.OBL.M.SG
re maj rakʰ dija
 in keep give.PFV.M.PL

'She kept her flowers in Bhomlii's vase.' [*dʒʰut* / FALSE]

- (g) *ba apra pʰul rakʰ dija dʒətʰe bʰomli*
 that.F.SG own.M.PL flower.M.PL keep give.LGT.PFV.M.PL where Bhomlii
uŋa-ne har dɪn dekʰ səke
 those.OBL-ACC each day see able.SUBJ.3

'She put her flowers where Bhomlii is able to see them every day.'
[*d̪ʒʰut* / FALSE]

(29) *uʃa əɾ bʰomli bəhʉt rəd̪ʒi hoti*
Usha and Bhonii very happy.F.PL be.IMPFV.F.PL

'Usha and Bhonii were very happy.'

(30) *d̪ʒjoti gəɳi ris maj hi*
Jyoti much.OBL.F anger.OBL.F in be.PST.F.SG

'Jyoti was very angry.'

(31) *abe tʰe d̪ʒaɳo ke d̪ʒjoti ne uʃa əɾ bʰomli*
now you.HON know.IMPFV.M.SG COMP Jyoti DAT Usha and Bhonii
kyō pasənd koni
why liking NEG

'And now you know why Jyoti doesn't like Usha and Bhonii.'

Appendix C

Testing for presuppositions: Tiger in the Bush story

C.1 Introduction

The *Tiger in the bush* story was developed to test whether correlatives carry presuppositions using the wait-a-minute response test (Matthewson 2006). The procedures for this test are outlined in Chapter 8.

Tiger in the bush is from the Jodhpur variety of Marwari. The first version of the story involved translating each sentence of the story from Hindi into Marwari. The story was then rechecked as a whole with two speakers who were asked to make sure the story was natural and how a Marwari might speak the same story. In this way, the grammaticality of each sentence was checked separately from the felicity of the sentence in the context.

Where consultants said that a sentence or line needed to be changed, the revised sentence is given immediately following the previous. I have used # to indicate those sentences which were considered infelicitous in the context.

C.2 Tiger in the bush

- (1) *ek tem ri bat he*
one time of.F.SG matter.F be.PRS.3.SG

'Once upon a time ... '

Lit.: 'One time something happened.'

- (2) *ek neno gāv d̄ʒin-nō nam hangeria*
 one small.M.SG village.M.SG which.OBL.SG-of.M.SG name.M.SG Sangaria
gāv ho
 village be.PST.M.SG

'There was a small village which was called Sangaria village.'

- (3) a. # *d̄ʒiko minək sarefjā gāv ũ*
 which.M.SG man.M.SG Sarechan village.OBL.M.SG from
aijo ho vo apre pirvar
 come.PFV.M.SG PST.3.SG that own.OBL.M.SG family.OBL.M.SG
re hat^e pa|a-pa|a d̄ʒaũto
 with on-foot.REDUP go.IMPV.PST.M.SG

'Which man was from Sarechan, that was walking along with his family.'

- b. Revised:

ek minək sarefjā gāv ũ aijo
 one man.M.SG Sarechan village.OBL.M.SG from come.PFV.M.SG
ho
 PST.3.SG

'There was a man from Sarechan.'

vo apre pirvar re hat^e pa|a-pa|a d̄ʒaũto
 that own.OBL.M.SG family.M.SG with on-foot.REDUP go.IMPV.PST.M.SG

'He was walking along with his family.'

- (4) *ek dəm ũ minək re neɾe ek babulijā ũ ek*
 one moment.OBL from man.M.SG near one bush.OBL.M.SG in one
avad̄ʒ aji
 voice.F.SG come.PFV.F.SG

'Suddenly a sound came from the bushes near the man.'

- (5) *vo hako veqo ni he d̄zεdo*
 that.M.SG sound.M.SG that.kind.M.SG NEG be.PRS.3.SG what.kind.M.SG
vo peʔli kadi hunijo ho
 first.F.SG incident.F.SG hear.PFV.M.SG be.PST.M.SG

‘That sound was not like any sound which he had ever heard before.’

Lit.: ‘that sound was not that kind, what kind he had heard before.’

- (6) *d̄zəd vo hako babulija re mē ũ ajo*
 when that.M.SG sound.M.SG bush.OBL.M.SG in from come.PFV.M.SG
ho unə-ro t̄ʰoro apri mā re lare
 PST.M.SG that.OBL-of.M.SG boy.M.SG own.F.SG mother.F.SG behind
luk go
 hide go.LGT.PFV.M.SG

‘When the sound came from the bush, his son hid behind his (own) mother.’

- (7) *un-ni mā ʔi dəʔ gi*
 that.OBL-of.F.SG mother.F.SG also afraid go.LGT.PFV.F.SG

‘His mother was also afraid.’

- (8) *t̄ʰoro kajo d̄zəko fer babulijā mē he*
 boy.M.SG say.PFV.M.SG which.M.SG tiger.M.SG bush.OBL in be.PRS.3.SG
vo heŋa-ne kʰaji d̄zaji
 that.M.SG all.OBL.PL-ACC eat light.FUT.F.SG

‘The boys said: which tiger is in the bush, that is going to eat us all!’

- (9) a. *va t̄ʰori bʰi d̄ərti hi pəŋa ba*
 that.F.SG girl.F.SG also scared.IMPV.F.SG be.PST.F.SG but that.F.SG
bʰaduri dikʰau-ŋi kosis kidi
 brave show-INF.F.SG attempt do.PFV.F.SG

‘That girl was also scared but she tried to appear brave.’

b. Revised:

un-ri *bɛɔɪn* *bʰi* *ɔ̄ɔɪti* *hi*
that.OBL-of.F.SG sister.F.SG also scared.IMPV.F.SG be.PST.F.SG
pəŋa ba *bʰaduri* *dikʰau-ŋi* *kosis* *kidi*
but that.M.SG brave.F.SG show-INF.F.SG attempt do.PFV.F.SG

'His sister was also scared but she tried to appear brave.'

- (10) *tu* *kikər* *ɔ̄zəŋɛ* *hɛ* *ke* *vo* *fɛr*
you how_Q know.IMPV.3.SG PRS.3.SG COMP that.M.SG tiger.M.SG
hɛ
be.PRS.3.SG

'How do you know that that is a tiger?'

- (11) *ho səke* *ke* *vo* *bandro* *hɛ*
be able.SUBJ.3.SG COMP that.M.SG monkey.M.SG be.PRS.3.SG

'It's possible that that is a monkey.'

- (12) *pəŋə vo* *sajət* *undro* *ho səke* *hɛ*
but that.M.SG maybe mouse.M.SG be able.SUBJ.3.SG be.PRS.3.SG
mã *hako* *kərijo*
mother sound do.PFV.M.SG

'But it's possible that it is a mouse! mother said.'

- (13) *kaji* *ɔ̄zəkɔ* *əɔ̄zəb-gəɔ̄zəb* *hako* *babulijã* *ũ* *ave*
do_Q which.M.SG strange-REDUP sound bush.OBL from come.IMPV.PRS.3.SG
ek *undro* *ɛɔ* *hako* *kər səke*
one mouse.M.SG that.kind.M.SG sound.M.SG do able.SUBJ.3.SG

'Which strange sound is coming from the bush, can a mouse make that kind of sound?'

- (14) a. # *papa bolijo ke koi deŋ koni*
 Papa spoke.PFV.M.SG COMP some worry NEG

'Papa said: don't worry.'

- b. Revised:

o minək bolijo ke koi deŋ koni
 that.M.SG man.M.SG spoke.PFV.M.SG COMP some worry NEG

'That man said: don't worry.'

- (15) *mē tʰan-ne həmaɭu la*
 I you.OBL.PL-ACC protect give.SUBJ.1.M

'I will protect you!'

- (16) *ne vo ek daɭi hatʰ mē le ne*
 and that.M.SG one stick.F.SG hand.OBL in take.PFV.3.SG and
babulijā kəne kudijo ne d̥ʒor ũ haku kərijo
 bush near jump.PFV.M.SG and loudness with sound do.PFV.M.SG
d̥ʒju riǰā bəɖiodo hatʰi hove
 what.manner anger burning elephant be.IMPV.3.SG

'And he took a stick in his hand and jumped toward the bush with a loud sound as if he were an angry elephant.'

Lit.: 'And he took a stick in his hand and jumped near the bush and loudly made a sound which way an elephant burning with angry is.'

- (17) *ek dəm babulija hɪlajo əɾ tʃəntʃerijo əɾ*
 one moment bush shake.PFV.M.SG and tremble.PFV.M.SG and
un-ũ ek gəŋo moɔo hevalo ajo
 that.OBL-from one very.M.SG fat.M.SG porcupine come.PFV.3.SG

'Suddenly the bush shook and trembled, and a very fat porcupine came out of it.'

- (18) *d̥ʒiko hevalo babulijã ã b^hare ajo*
 which.M.SG porcupine.M.SG bush.OBL.M.SG from outside come.PFV.M.SG
d̥ʒit:o vo m^hanko un-ũ dare
 how.much.M.SG that.M.SG person.M.SG that.OBL-from scared.IMPFV.3.SG
he un-ũ bato vo hevalo
 be.PRS.3.SG that.OBL-from more.M.SG that.M.SG porcupine
m^hanka ã dare he
 person.OBL.M.SG from afraid.IMPFV.3.SG be.PRS.3.SG

‘The porcupine who ran out of the bushes was more scared of the people than the people were scared of him.’

Lit.: ‘Which porcupine came out of the bush, how scared the man was of him, the porcupine was more scared of the people than that.’

- (19) *ne heŋ g^hər-a|a d̥ʒim bablija ã hako*
 and all house-one.M.PL which.OBL bush.OBL from sound
ave t^ho un balijã ã b^hego
 come.IMPFV.3.SG be.PST.M.SG that.OBL bush.OBL from run-away
gaja
 go.PFV.M.PL

‘And the whole family turned and ran away from the bush the noise had come from.’

Lit.: ‘And the whole family ran away from, which bush the sound had come from, that bush.’

Bibliography

- Abbi, A. (2001). *A manual of linguistic field work and structures of Indian languages*, volume 17. Lincom Europa.
- Abney, S. P. (1987). *The English noun phrase in its sentential aspect*. PhD thesis, Massachusetts Institute of Technology.
- Andrews, A. (1985). *Studies in the Syntax of Relative and Comparative Clauses*. Outstanding Dissertations in Linguistics, Garland, New York.
- Bagchi, T. (1994). Bangla correlative pronouns, relative clause order and D-linking. *Theoretical Perspectives on Word Order in South Asian Languages, CSLI Lecture Notes*, 50:13–30.
- Beck, S. (2011). Comparison constructions. *Semantics: An International Handbook of Natural Language Meaning*.
- Berntsen, M. and Nimbkar, J. (1975). *A Marathi Reference Grammar*. ERIC.
- Bhatt, R. (1997). Matching effects and the syntax-morphology interface: Evidence from Hindi correlatives. *MIT Working Papers in Linguistics*, 31:53–68.
- Bhatt, R. (2003). Locality in correlatives. *Natural Language & Linguistic Theory*, 21(3):485–541.
- Bhatt, R. (2011). Ergativity in katchi. *South Asian Languages Analysis Roundtable*, 29.
- Bhatt, R. and Dayal, V. (2007). Rightward scrambling as rightward remnant movement. *Linguistic Inquiry*, 38(2):287–301.
- Bhatt, R. and Lipták, A. (2009). Matching effects in the temporal and locative domains. In Lipták, A., editor, *Correlatives cross-linguistically*, pages 343–372. John Benjamins Publishing.

- Bhatt, R. and Pancheva, R. (2002). A cross-constructural analysis of if clauses. In *Syntax Seminar: interface in the CP domain*, volume 9.
- Bianchi, V. (2002a). Headed relative clauses in generative syntax, part i. *Glott International*, 6(7).
- Bianchi, V. (2002b). Headed relative clauses in generative syntax. part ii. *Glott International*, 6(8):1–13.
- Bochnak, M. R. and Matthewson, L. (2015). Introduction. In Bochnak, M. R. and Matthewson, L., editors, *Methodologies in Semantic Fieldwork*, pages 1–10. Oxford University Press, USA.
- Bresnan, J. and Grimshaw, J. (1978). The syntax of free relatives in english. *Linguistic inquiry*, 9(3):331–391.
- Butt, M. and Deo, A. (2005). Ergativity in indo-aryan. *Ms., Konstanz and Stanford*.
- Cable, S. (2009). The syntax of the Tibetan correlative. In Lipták, A., editor, *Correlatives cross-linguistically*, pages 195–222. John Benjamins Publishing.
- Cable, S. (2010). *The grammar of Q: Q-particles, wh-movement, and pied-piping*. Oxford University Press.
- Cameron, H. (2006). An examination of the demographic impact of "transnational marriage" between citizens of the uk and the indian sub-continent. *Political Demography: Ethnic, National and Religious Dimensions*.
- Caponigro, I. (2003). *Free not to ask: On the semantics of free relatives and wh-words cross-linguistically*. PhD thesis, Citeseer.
- Caponigro, I., Pearl, L., Brooks, N., and Barner, D. (2012). Acquiring the meaning of free relative clauses and plural definite descriptions. *Journal of Semantics*, 29(2):261–293.
- Christianson, K., Hollingworth, A., Halliwell, J. F., and Ferreira, F. (2001). Thematic roles assigned along the garden path linger. *Cognitive psychology*, 42(4):368–407.
- Chung, S. and Ladusaw, W. A. (2004). *Restriction and saturation*. MIT press.

- Citko, B. (2009). What don't wh-questions, free relatives, and correlatives have in common. In *Correlatives cross-linguistically*, page 49. John Benjamins Publishing.
- Cooper, R. (1983). *Quantification and Syntactic Theory*. Dordrecht: Reidel.
- Crain, S. and Thornton, R. (1998). *Investigations in universal grammar: a guide to research on the acquisition of syntax and semantics*. Cambridge, MA: MIT Press.
- Dauenhauer, N. M. and Dauenhauer, R. (2000). *Beginning Tlingit*. Sealaska Heritage Institute.
- Davison, A. (2009). Adjunction, features and locality in sanskrit and Hindi/urdu correlatives. *Correlatives cross-linguistically*, pages 223–262.
- Dayal, V. (1996). *Locality in WH quantification: Questions and relative clauses in Hindi*, volume 62 of *Studies in Linguistics and Philosophy*. Studies in Linguistics and Philosophy.
- Dayal, V. (1997). Free relatives and "ever": Identity and free choice readings. In *Semantics and Linguistic Theory*, volume 7, pages 99–116.
- de Vries, M. (2001). Patterns of relative clauses. *Linguistics in the Netherlands*, 18(1):231–243.
- de Vries, M. (2005). The fall and rise of universals on relativization. *Journal of Universal Language*, 6(1):125–157.
- den Dikken, M. (2005). Comparative correlatives comparatively. *Linguistic Inquiry*, 36(4):497–532.
- Dhongde, R. V. and Wali, K. (2009). *Marathi*. John Benjamins Publishing.
- Downing, B. (1973). Correlative relative clauses in universal grammar. *Minnesota Working Paper in Linguistics and Philosophy of Language*, 2:1–17.
- Dwivedi, V. (1994). *Syntactic dependencies and relative phrases in Hindi*. PhD thesis, University of Massachusetts.
- Elbourne, P. (2008). Demonstratives as individual concepts. *Linguistics and Philosophy*, 31(4):409–466.

- Elbourne, P. (2013). *Definite Descriptions*, volume 1. Oxford University Press.
- Elbourne, P. D. (2005). *Situations and individuals*. MIT Press.
- Ferreira, F. and Henderson, J. M. (1998). Syntactic reanalysis, thematic processing, and sentence comprehension. In *Reanalysis in sentence processing*, pages 73–100. Springer.
- Fox, D. and Johnson, K. (2016). Qr is restrictor sharing. In *Proceedings of the rd West Coast Conference on Formal Linguistics,–. Somerville, MA: Cascadilla Proceedings Project*.
- Frege, G. (1882). On the scientific justification of a conceptual notation. *Conceptual notation and related articles*, pages 83–89.
- Gajewski, J. (2008). On the semantics of Hindi-Urdu multiple correlatives. *Linguistic Inquiry*, 39(2):327–334.
- Gambhir, V. (1981). *Syntactic restrictions and discourse functions of word order in standard Hindi*. PhD thesis, University of Pennsylvania.
- Grierson, G. (1908). Report on the linguistic survey of india, presented to the fifteenth international congress of orientalis. *Journal of the Royal Asiatic Society (New Series)*, 40(04):1127–1131.
- Groos, A. and van Riemsdijk, H. (1979). Matching effects in free relatives: A parameter of core grammar. In *Theory of Markedness in Generative Grammar*. Proceedings of the GLOW Conference. Scuola Normale Superiore di Pisa, Pisa.
- Grosu, A. and Landman, F. (1998). Strange relatives of the third kind. *Natural Language Semantics*, 6(2):125–170.
- Gusain, L. (2004). *Marwari*, volume 427. Lincom.
- Hagstrom, P. A. (1998). *Decomposing questions*. PhD thesis, Massachusetts Institute of Technology.
- Hamblin, C. L. (1973). Questions in montague english. *Foundations of language*, 10(1):41–53.
- Heim, I. (1982). *The semantics of definite and indefinite noun phrases*. PhD thesis, University of Massachusetts.

- Heim, I. (1983). On the projection problem for presuppositions. In Portner, P. H. and Partee, B. H., editors, *Formal semantics: The essential readings*, pages 249–260. Wiley.
- Heim, I. (1991). Articles and definiteness. *Semantics. An international handbook of contemporary research*.
- Hendery, R. (2012). *Relative Clauses in Time and Space: A case study in the methods of diachronic typology*, volume 101. John Benjamins Publishing.
- Herskovits, A. (1986). *Language and spatial cognition: an interdisciplinary study of the prepositions in English*. Cambridge University Press.
- Hinterwimmer, S. (2008). *Q-adverbs as selective binders: The quantificational variability of free relatives and definite DPs*, volume 14. Walter de Gruyter.
- Holmberg, A. (2000). Scandinavian stylistic fronting: How any category can become an expletive. *Linguistic inquiry*, 31(3):445–483.
- Huang, C. J. (1982). Move wh in a language without wh movement. *The linguistic review*, 1(4):369–416.
- Izvorski, R. (1996). The syntax and semantics of correlative proforms. In *Proceedings-NELS*, volume 26, pages 133–148. University of Massachusetts.
- Izvorski, R. (2000). Free adjunct free relatives. In *Proceedings of WCCFL*, volume 19, pages 232–245.
- Jacobson, P. (1995). On the quantificational force of English free relatives. *Quantification in natural languages*, 2:451.
- Jayaseelan, K. (1989). Question word movement in Malayalam. *Hyderabad: CIEFL (Ms.)*.
- Jayaseelan, K. A. (1996). Question-word movement to focus and scrambling in Malayalam. *Linguistic Analysis*, 26:63–83.
- Kachru, Y. (1973). Some aspects of pronominalization and relative clause construction in Hindi-urdu. *Studies in the Linguistic Sciences*, 3(2):87–103.
- Kachru, Y. (1978). On relative clauses formation in Hindi-Urdu. *Linguistics*, 16(207):5–26.

- Kachru, Y. (2006). *Hindi*, volume 12 of *London Oriental and African Language Library*. John Benjamins Publishing.
- Karttunen, L. (1977). Syntax and semantics of questions. *Linguistics and Philosophy*, 1(1):3–44.
- Keenan, E. (1985). Language typology and syntactic description. In Shopen, T., editor, *Relative Clauses*, volume 2, pages 141–170. Cambridge University Press, Cambridge.
- Keenan, E. L. and Comrie, B. (1977). Noun phrase accessibility and universal grammar. *Linguistic inquiry*, 8(1):63–99.
- Kidwai, A. (2000). *XP-adjunction in universal grammar: scrambling and binding in Hindi-Urdu*. Oxford University Press.
- King, J. D. (2001). *Complex Demonstratives: A Quantificational Account*. The MIT Press.
- Kishimoto, H. (2005). Wh-in-situ and movement in Sinhala questions. *Natural Language & Linguistic Theory*, 23(1):1–51.
- Kotek, H. (2014). *Composing questions*. PhD thesis, Massachusetts Institute of Technology.
- Koul, O. N. (2008). *Modern Hindi Grammar*. Indian Institute of Language Studies, Dunwoody Press.
- Koul, O. N. and Wali, K. (2006). *Modern Kashmiri Grammar*. Dunwoody Press.
- Kratzer, A. (1996). Severing the external argument from its verb. In *Phrase structure and the lexicon*, pages 109–137. Springer.
- Kratzer, A. (2004). Covert quantifier restrictions in natural languages. *Talk given at Palazzo Feltrenelli, Gargnano, Italy*.
- Krishnamurti, B. (2003). *The dravidian languages*. Cambridge University Press.
- Kuroda, S. (1982). Indexed predicate calculus. *Journal of Semantics*, 1(1):43–59.

- Lahiri, U. (2002). *Questions and answers in embedded contexts*. Oxford University Press.
- Lal, V. (1999). Not this, not that: The hijras of india and the cultural politics of sexuality. *Social Text*, (61):119–140.
- Lambert, H. (1971). *A Gujarati Language Course*. Cambridge University Press.
- Lasnik, H. and Saito, M. (1992). *Move α* . Cambridge, Mass.: MIT Press.
- Lehmann, C. (1984). *Der Relativsatz*. PhD thesis, Gunter Varr Nerlag.
- Lewis, M. P., Simons, G. F., and Fennig, C. D., editors (2016). *Ethnologue: Languages of the World, Nineteenth edition*. Online version: <http://www.ethnologue.com>. SIL International.
- Liljegren, H. (2008). *Towards a grammatical description of Palula: An Indo-Aryan language of the Hindu Kush*. PhD thesis, Institutionen för lingvistik.
- Lillo-Martin, D. and Klima, E. S. (1990). Pointing out differences: Asl pronouns in syntactic theory. *Theoretical issues in sign language research*, 1:191–210.
- Link, G. (1983). The logical analysis of plurals and mass terms: A lattice theoretical approach. *Formal Semantics: The Essential Readings*, pages 249–260.
- Lipták, A. (2009). The landscape of correlatives. In Lipták, A., editor, *Correlatives cross-linguistically*, pages 1–48. John Benjamins Publishing.
- Louis, M. (2015). The problem with no-nonsense elicitation plans (for semantic fieldwork). *Methodologies in semantic fieldwork*, pages 47–71.
- Macaulay, M. (2012). Training linguistics students for the realities of fieldwork. In Thieberger, N., editor, *The Oxford Handbook of Linguistic Fieldwork*, pages 457–472. Oxford University Press.
- Magier, D. (1983). *Topics in the Grammar of Marwari*. PhD thesis, University of California, Berkeley.

- Mahajan, A. (2000). The syntax of relative clauses. In *Relative asymmetries and Hindi correlatives*, volume 32, pages 201–229. John Benjamins Publishing.
- Mahajan, A. K. (1994). Against the relevance of subjacency at lf: The case of Hindi wh. *Linguistic Inquiry*, pages 171–179.
- Majid, A. (2012). A guide to stimulus-based elicitation for semantic categories. In Thieberger, N., editor, *The Oxford Handbook of Linguistic Fieldwork*, pages 54–71. Oxford University Press.
- Masica, C. P. (1993). *The indo-aryan languages*. Cambridge University Press.
- Matthewson, L. (2004). On the methodology of semantic fieldwork. *International journal of American linguistics*, 70(4):369–415.
- Matthewson, L. (2006). Presuppositions and cross-linguistic variation. *Proceedings of SALT XVIII*, pages 527–550.
- McCawley, J. D. (1994). Some graphotactic constraints. In *Writing systems and cognition*, pages 115–127. Kluwer Academic Publishers.
- McCawley, J. D. (2004). Remarks on adsentential, adnominal, and extraposed relative clauses in Hindi. In Dayal, V. and Mahajan, A., editors, *Clause structure in South Asian languages*, pages 291–311. Kluwer Academic Publishers, Netherlands.
- Meier, R. P. (1990). Person deixis in american sign language. *Theoretical issues in sign language research*, 1:175–190.
- Mitchell, L. (2005). Parallel languages, parallel cultures: Language as a new foundation for the reorganisation of knowledge and practice in southern India. *The Indian Economic & Social History Review*, 42(4):445–467.
- Mitchell, L. (2006). Making the local foreign: Shared language and history in southern India. *Journal of Linguistic Anthropology*, 16(2):229–248.
- Mosel, U. (2012). Morphosyntactic analysis in the field: A guide to the guides. In Thieberger, N., editor, *The Oxford Handbook of Linguistic Fieldwork*, pages 72–89. Oxford University Press.

- Müller, G. and Sternefeld, W. (1993). Improper movement and unambiguous binding. *Linguistic inquiry*, 24(3):461–507.
- Nanda, S. (1994). *Hijras*. Wiley Online Library.
- Nanda, S. (2003). Hijra and sadhin. *Constructing sexualities: readings in sexuality, gender, and culture*, page 192.
- Neale, S. (1990). *Descriptions*. PhD thesis, MIT Press, Cambridge.
- Nunberg, G. (1993). Indexicality and deixis. *Linguistics and Philosophy*, 16(1):1–43.
- Pandharipande, R. (1997). *Marathi*. Psychology Press.
- Partee, B. (1987). Noun phrase interpretation and type-shifting principles. In Guti(e)rrez-Rexach, J., editor, *Semantics: Critical concepts in linguistics, Generalized quantifiers and scope (2009)*, volume II, pages 152–180. Routledge.
- Perry, J. and Blackburn, S. (1986). Thought without representation. *Proceedings of the Aristotelian society, supplementary volumes*, 60:137–166.
- Pesetsky, D. (2007). Undermerge... and the secret genitive inside every russian noun. *Handout of a talk at FASL*, 16.
- Pesetsky, D. (2013). *Russian case morphology and the syntactic categories*. MIT Press.
- Potts, C., Asudeh, A., Cable, S., Hara, Y., McCready, E., Alonso-Ovalle, L., Bhatt, R., Davis, C., Kratzer, A., Roeper, T., et al. (2009). Expressives and identity conditions. *Linguistic Inquiry*, 40(2):356–366.
- Ramchand, G. and Svenonius, P. (2007). Licensing directional interpretations: Summary of results from mra seminars in 2005-6. *Ms., CASTL, University of Tromsø*.
- Rebuschi, G. (2009). Basque correlatives and their kin in the history of northern basque. In *Correlatives cross-linguistically*, pages 81–130. John Benjamins Publishing.
- Recanati, F. (1996). Domains of discourse. *Linguistics and Philosophy*, 19(5):445–475.

- Recanati, F. (2005). Literalism and contextualism: Some varieties. *Contextualism in philosophy: Knowledge, meaning, and truth*, pages 171–196.
- Roberts, C. (2003). Uniqueness in definite noun phrases. *Linguistics and Philosophy*, 26(3):287–350.
- Rooth, M. (1985). *Association with focus*. PhD thesis, University of Massachusetts.
- Rooth, M. (1992). A theory of focus interpretation. *Natural language semantics*, 1(1):75–116.
- Ross, J. R. (1967). *Constraints on variables in syntax*. PhD thesis, Massachusetts Institute of Technology.
- Safir, K. (1999). Vehicle change and reconstruction in \bar{a} -chains. *Linguistic inquiry*, 30(4):587–620.
- Sandler, W. and Lillo-Martin, D. (2006). *Sign language and linguistic universals*. Cambridge University Press.
- Sauerland, U. (2000). Two structures for english restrictive relative clauses. In *Proceedings of the Nanzan GLOW*, pages 351–366. Nanzan University Nagoya.
- Schlenker, P. (2013). Temporal and modal anaphora in sign language (ASL). *Natural Language & Linguistic Theory*, 31(1):207–234.
- Schlenker, P. (2014). Iconic features. *Natural Language Semantics*, 22(4):299–356.
- Schlenker, P., Aristodemo, V., Ducasse, L., Lamberton, J., and Santoro, M. (2016). The unity of focus: Evidence from sign language (ASL and LSF). *Linguistic Inquiry*.
- Snell, R. and Weightman, S. (2005). *Teach Yourself Hindi*. Teach Yourself.
- Srivastav, V. (1991). *WH Dependencies in Hindi and the Theory of Grammar*. unpublished PhD, Cornell University.
- Stowell, T. A. (1981). *Origins of phrase structure*. PhD thesis, Massachusetts Institute of Technology.

- Strawson, P. F. (1950). On referring. *Mind*, 59(235):320–344.
- Subbarao, K. V. (1984). *Complementation in Hindi syntax*, volume 1. Academic Publications.
- Svenonius, P. (2004). Spatial p in english. *ms. University of Tromsø*.
- Svenonius, P. (2006). The emergence of axial parts.
- Svenonius, P. (2008). The position of adjectives and other phrasal modifiers in the decomposition of dp. *Adjectives and adverbs: Syntax, semantics, and discourse*, pages 16–42.
- Svenonius, P. (2010). Spatial p in English. In Cinque, G. and Rizzi, L., editors, *Mapping Spatial Ps*, volume 6, pages 127–160. Oxford University Press Oxford.
- Talmy, L. (1978). Relations between subordination and coordination. *Universals of human language: Syntax*, 4:487–513.
- Talmy, L. (2000). *Toward a cognitive semantics*, volume 1. MIT press.
- Traxler, M. J., Morris, R. K., and Seely, R. E. (2002). Processing subject and object relative clauses: Evidence from eye movements. *Journal of Memory and Language*, 47(1):69–90.
- Truswell, R. and Gisborne, N. (2016). Where do relative specifiers come from? In *Micro-change and Macro-change in Diachronic Syntax*. In press, Oxford University Press.
- Van Riemsdijk, H. (1990). Functional prepositions. *Unity in Diversity, edited by H. Pinkster and I. Gene*, pages 229–241.
- von Stechow, K. (2001). Would you believe it? the king of france is back! presuppositions and truth value intuitions. In Bezuidenhout, A. and Reimer, M., editors, *Descriptions and beyond*. Oxford University Press.
- von Stechow, K. and Matthewson, L. (2008). Universals in semantics. *The linguistic review*, 25(1-2):139–201.
- Vries, M. d. et al. (2002). *The syntax of relativization*. LOT.

- Wali, K. (1982). South Asian review: Studies in South Asian languages and linguistics. In Mistry, P. J., editor, *Marathi Correlatives: A Conspectus*, volume 6 of *SALA Journal*, pages 78–88. South Asian Literary Association, Jacksonville, Florida.
- Wali, K. and Koul, O. N. (1997). *Kashmiri: A cognitive-descriptive grammar*. Psychology Press.
- Wanner, E. and Maratsos, M. (1978). Linguistic theory and psychological reality. *Linguistic Theory and Psychological Reality*.
- Webber, B. L. (1988). Discourse deixis: Reference to discourse segments. In *Proceedings of the 26th annual meeting on Association for Computational Linguistics*, pages 113–122. Association for Computational Linguistics.
- Woolard, K. A. and Schieffelin, B. B. (1994). Language ideology. *Annual review of Anthropology*, 23(1):55–82.
- Wunderlich, D. (1991). How do prepositional phrases fit into compositional syntax and semantics? *Linguistics*, 29(4):591–622.
- Yuan, M. (2017). More on Undermerge: Phrasal and head movement interactions in Kikuyu. In *A Pesky Set: Papers for David Pesetsky*, volume 80, pages 543–552. MIT Working Papers in Linguistics.
- Zribi-Hertz, A. and Hanne, J. (1995). Pronoms, determinants et relatives en bambara de Bamako. *Linguistique africaine*, 15:91–136.
- Zwarts, J. (1997). Lexical and functional properties of prepositions. *Lexikalische und grammatische Eigenschaften präpositionaler Elemente. Linguistische Arbeiten*, 371:1–19.
- Zwarts, J. and Winter, Y. (2000). Vector space semantics: A model-theoretic analysis of locative prepositions. *Journal of logic, language and information*, 9(2):169–211.