



THESIS SUBMITTED FOR THE DEGREE OF
DOCTOR OF PHILOSOPHY

COUNTING AND CORRELATORS
IN QUIVER GAUGE THEORIES

PAOLO MATTIOLI

Supervisor

DR. SANJAYE K. RAMGOOLAM

June 2016

Centre for Research in String Theory
School of Physics and Astronomy
Queen Mary University of London

Declaration

I, Paolo Mattioli, confirm that the research included within this thesis is my own work or that where it has been carried out in collaboration with, or supported by others, that this is duly acknowledged below and my contribution indicated. Previously published material is also acknowledged below.

I attest that I have exercised reasonable care to ensure that the work is original, and does not to the best of my knowledge break any UK law, infringe any third party's copyright or other Intellectual Property Right, or contain any confidential material.

I accept that the College has the right to use plagiarism detection software to check the electronic version of the thesis.

I confirm that this thesis has not been previously submitted for the award of a degree by this or any other university.

The copyright of this thesis rests with the author and no quotation from it or information derived from it may be published without the prior written consent of the author.

Signature:

A handwritten signature in black ink that reads "Paolo Mattioli". The signature is written in a cursive style with a long horizontal flourish extending to the right.

Date: December 21, 2016

Details of collaboration and publications:

This thesis describes research carried out with my supervisor Sanjaye K. Ramgoolam which was published in [1–3].

*This thesis is dedicated to my parents
for their unconditional support and love.*

Acknowledgements

First and foremost, I want to thank my supervisor Sanjaye K. Ramgoolam. His guidance throughout my Ph.D. has been invaluable, and I owe to him all the progress that I have made since I first joined Queen Mary. His passion for physics and his drive have truly been an inspiration for me.

I would also like to thank my colleagues and friends Joel Berkeley, David Garner, Joseph Hayling, Edward Hughes, Zachary Kenton, Martyna Kostacinska, James McGrane, Robert Mooney, Emanuele Moscato, Rodolfo Panerai, Brenda Penante, Sam Playle and Felix Rudolph for all the discussions we had over the years. They have all been a very important part of my everyday life, and will not be forgotten.

Abstract

Quiver gauge theories are widely studied in the context of AdS/CFT, which establishes a correspondence between CFTs and string theories. CFTs in turn offer a map between quantum states and Gauge Invariant Operators (GIOs). This thesis presents results on the counting and correlators of holomorphic GIOs in quiver gauge theories with flavour symmetries, in the zero coupling limit.

We first give a prescription to build a basis of holomorphic matrix invariants, labelled by representation theory data. A finite N counting function of these GIOs is then given in terms of Littlewood-Richardson coefficients. In the large N limit, the generating function simplifies to an infinite product of determinants, which depend only on the weighted adjacency matrix associated with the quiver. The building block of this product has a counting interpretation by itself, expressed in terms of words formed by partially commuting letters associated with closed loops in the quiver. This is a new relation between counting problems in gauge theory and the Cartier-Foata monoid. We compute the free field two and three point functions of the matrix invariants. These have a non-trivial dependence on the structure of the operators and on the ranks of the gauge and flavour symmetries: our results are exact in the ranks, and their expansions contain information beyond the planar limit.

We introduce a class of permutation centraliser algebras, which give a precise characterisation of the minimal set of charges needed to distinguish arbitrary matrix invariants. For the two-matrix model, the relevant non-commutative algebra is parametrised by two integers. Its Wedderburn-Artin decomposition explains the counting of restricted Schur operators. The structure of the algebra, notably its dimension, its centre and its maximally commuting sub-algebra, is related to Littlewood-Richardson numbers for composing Young diagrams.

Contents

1	Introduction	9
1.1	Strings, dualities and quivers	9
1.2	The one and two-matrix problem in $\mathcal{N} = 4$ Super Yang-Mills: multi-trace operators and giant gravitons	10
1.2.1	One-matrix problem	12
1.2.2	Two-matrix problem	19
1.3	Generalisation to quiver gauge theories	23
1.4	Definitions and framework	25
2	Counting Functions and the Cartier-Foata Monoid	28
2.1	From gauge invariants to determinants and word counting	31
2.1.1	Generalization to flavoured quivers	32
2.2	Group integral formula to partition sums	33
2.2.1	The generating function \mathcal{Z} and the building block $F^{[n]}$	41
2.3	The unflavoured case: contour integrals and paths on graphs	42
2.3.1	$F_0^{[n]}$ and the sum over subsets	50
2.3.2	$F_0^{[n]}$ and determinants	51
2.4	Word counting and the building block $F_0^{[n]}$	52
2.5	The flavoured case: from contour integrals to a determinant expression	57
2.6	A few examples	60
2.6.1	One node quiver	60
2.6.2	Two node quiver	63
2.6.3	Three node quiver: dP_0	65
3	Correlators in the Quiver Restricted Polynomials Basis	67
3.1	Gauge invariant operators and permutations	69
3.2	The quiver restricted Schur polynomials	75
3.2.1	The quiver characters	79
3.3	Two and three point functions	83
3.3.1	Hilbert space of holomorphic gauge invariant operators	83
3.4	Chiral ring structure constants and three point functions	88
3.4.1	Diagrammatic derivation for an $\mathcal{N} = 2$ SQCD	94

3.5	An example: quiver restricted Schur polynomials for an $\mathcal{N} = 2$ SQCD	97
4	Permutation Centraliser Algebras	108
4.1	Definitions and Key examples	110
4.2	Structure of the $\mathcal{A}(m, n)$ algebra	111
4.2.1	Symmetric group characters and the pairing on the centre $\mathcal{Z}(m, n)$. . .	116
4.2.2	Maximal commuting subalgebra	119
4.3	Star product for composite operators	120
4.3.1	One matrix problem	120
4.3.2	Two matrix problem	123
4.3.3	Cartan subalgebra and the minimal set of charges	127
4.4	Computation of the finite N correlator	128
4.5	Numerical checks, possible applications and other examples	131
4.5.1	Structure of the centre	131
4.5.2	Construction of quarter-BPS operators beyond zero coupling and the structure constants of $\mathcal{A}(m, n)$	132
4.5.3	Non-commutative geometry and topological field theory	133
4.5.4	Other examples of permutation centralizer algebras and correlators . . .	134
5	Conclusions and Outlook	137
	Appendices	140
A	Quiver Characters and Correlators: Proofs	141
A.1	Operator invariance	141
A.2	Quiver character identities	144
A.2.1	Invariance Relation	144
A.2.2	Orthogonality relations	147
A.3	Deriving the holomorphic gauge invariant operator ring structure constants . . .	156
A.4	Quiver restricted Schur polynomials for an $\mathcal{N} = 2$ SQCD: $\vec{n} = (2, 2, 2)$ field content	169
B	Proofs and Derivation of the Counting Formulae	176
B.1	Generating function	176
B.1.1	Derivation of the generating function	176
B.1.2	A contour integral formulation for $F^{[n]}$	181
B.2	Residues and constraints	190
B.3	Three node unflavoured quiver example	194
B.3.1	Permutation formula	197
B.3.2	Determinant formula	198
B.4	An equation for the pole coefficients in term of paths	199
B.5	The building block $F_0^{[n]}$ and closed string word counting: Examples	202
B.6	Deriving the flavoured $F^{[n]}$ function	205

C Useful Formulae for the Permutation Centraliser Algebras	210
C.1 Analytic formula for the dimension of $\mathcal{M}(m, n)$	210
C.1.1 Multi-variable polynomials	212
C.2 LR rule for hook representations	214
C.2.1 (Y,Y) case	215
C.2.2 (Y,N) case	216
C.2.3 (N,N) case	217
C.2.4 (N,Y) case	217
C.2.5 A summary	218
C.3 Deriving the two point correlator	220
Bibliography	222

Chapter 1

Introduction

1.1 Strings, dualities and quivers

String theory is one of the most promising candidates for a theory of everything. Born in the late '60s as a mathematical model to explain the dualities of strong interactions in nuclear physics [4], has been later reinterpreted as a possible way to consistently describe a unified theory of gravitation and quantum physics. It was found that the spectrum of a certain one-dimensional object propagating in spacetime, a bosonic closed string, contained an excitation with all the correct quantum numbers of a graviton. Some of the initial flaws of the model, most notably the absence of fermions and an unstable vacuum, have been overcome by the introduction of *supersymmetric* string theory. In a supersymmetric theory, bosonic and fermionic particles always come in pairs, and each pair shares important quantum numbers such as energy. It is however important to underline that the existence of supersymmetry in Nature has still to be proven. On the one hand, superstring theory is a remarkable model, truly a unifying theory. On the other hand, many questions are still unanswered. For example, the theory is mathematically sound only in ten dimensions. This value is known as the critical dimension of superstring theory, and is the only one for which the theory is not anomalous. Therefore the quest for the missing dimensions commenced. Many are the proposed solutions: according to one interpretation, the 6 missing dimensions are coiled up and form a compact topology, so small that we can not probe it even with the most powerful collider. This idea was proposed during the so-called first superstring revolution that started in 1984. That year signed the beginning of a period during which many important discoveries heightened the scientific interest in string theory. For example, it was found that the Green-Schwarz mechanism allowed for the anomaly cancellation in type I superstring theory [5]. This was probably the single most important result of the first superstring revolution. Other string theory models, such as the heterotic string, were theorised as well in this time frame. These models were also shown to be anomaly-free.

Between 1994-1996 the second superstring revolution began. In 1995 Edward Witten suggested that all the different string theory models could be particular limiting cases of a new eleven dimensional theory, “mother” to all of the others [6]. This is M-theory. In the same year Joseph Polchinski showed that, by themselves, strings are not enough to make a consistent

string theory, but one instead needs to add to the model other multi-dimensional extended objects [7]. This discovery considerably enriched the already vast mathematical landscape of string theory. Finally, in 1997 Juan Maldacena proposed a duality [8] between type IIB string theory propagating on a suitably chosen curved background, called $AdS_5 \times S^5$, and a supersymmetric gauge theory in four flat dimensions, $\mathcal{N} = 4$ Super Yang-Mills. This conjecture, called simply AdS/CFT, has different formulations differing by the strength of their statement, and gave a new thrust to string theory research. It is the most successful realisation of the holographic principle, firstly proposed by Gerard 't Hooft, which states that the physical description of a volume of space can in fact be encoded by the physics happening at its boundaries - not unlike an actual hologram. One of the many reasons why AdS/CFT is so important is that it is a weak-strong duality. This means that the strong interacting regime of one side of the duality, where it is hard to perform computations, is mapped to the weakly interacting regime on the other side, which is more tractable. It is however important to say that creating the explicit dictionary, that is mapping excitations on the gravity (string) side to excitations of the gauge theory side, is not an easy task, and only a few examples are known. Over the years, generalisations of the duality have been proposed. In these cases, the string theory is defined on a different background (still involving AdS space), and are dual to more exotic gauge theories, sometimes called *quiver* gauge theories. AdS/CFT is the central motivation of this thesis. We will be focusing on the gauge side, and in particular we will study the counting and correlators of matrix invariants in quiver gauge theories.

1.2 The one and two-matrix problem in $\mathcal{N} = 4$ Super Yang-Mills: multi-trace operators and giant gravitons

A number of questions on gauge invariant functions and correlators of multiple-matrices have been studied in the context of $\mathcal{N} = 4$ Super Yang-Mills (SYM). The impetus for these developments in physics, as we stated in the previous introductory section, has come from the AdS/CFT correspondence [8–10], notably the duality between the $\mathcal{N} = 4$ SYM theory with $U(N)$ gauge group and $AdS_5 \times S^5$. $\mathcal{N} = 4$ SYM is a maximally supersymmetric gauge theory in four dimension. Quite remarkably, it is the *only* consistent theory with these characteristics. On top of that it is a Conformal Field Theory (CFT), meaning that it does not flow under its Renormalisation Group action. The single coupling coefficient of the theory thus does not run when the energy scale is changed. The conformal symmetry of the theory gives extra motivation, because of the operator-state correspondence: quantum states correspond to gauge invariant local operators, which are composite fields. These can be matrix-valued fields which are space-time scalars, fermions, field strengths or covariant derivatives of these. A generic problem is to understand $U(N)$ invariants constructed from a number n of such fields

$$\mathcal{O}_{i_1, \dots, i_n}^{j_1, \dots, j_n} \sim \mathcal{F}_{1, i_1}^{j_1} \dots \mathcal{F}_{n, i_n}^{j_n} \quad (1.2.1)$$

This is subsequently used to understand their correlation functions. The n upper indices each transform in the fundamental of $U(N)$, which we call V , while the lower indices transform in the anti-fundamental, labelled \bar{V} . Hence, an important ingredient is the nature of the invariants in $V^{\otimes n} \otimes \bar{V}^{\otimes n}$. The number of linearly independent invariants is $n!$. They are obtained from (1.2.1) by suitably contracting all the upper indices with a permutation of the lower ones. Let us now focus on the special case in which all the \mathcal{F} fields are scalars. There are six real scalars in $\mathcal{N} = 4$ SYM, labelled ϕ^i , transforming in the fundamental representation of $SO(6)$ (or equivalently in the antisymmetric representation of the $SU(4)$ R-symmetry group). The euclidean action on $\mathbb{R} \times S^3$ for this bosonic scalar subsector is given by

$$S_\phi = \frac{N}{4\pi\lambda} \int_{\mathbb{R}} dx \int_{S^3} \frac{d\Omega_3}{2\pi^2} \left(\frac{1}{2} (D\phi^i)(D\phi^i) + \frac{1}{4} [\phi^i, \phi^j]^2 - \frac{1}{2} \phi^i \phi^i \right) \quad (1.2.2)$$

where $\lambda = g_{YM}^2 N$ is the 't Hooft coupling and D is the gauge covariant derivative. The mass term $\sim \phi^i \phi^i$ is a consequence of the conformal coupling to the metric of S^3 . It is customary then to combine these six real fields into three complex holomorphic fields

$$X = \phi_1 + i\phi_2, \quad Y = \phi_3 + i\phi_4, \quad Z = \phi_5 + i\phi_6 \quad (1.2.3)$$

The advantage of formulating the model in this way is that all half-BPS states of the gauge theory can be described in terms of an ordinary matrix quantum mechanics [11]. This is a consequence of the state-operator map. Half-BPS operators transform in the $[0, n, 0]$ representation of the $SU(4)$ R-symmetry group, and are eigenstates of the dilatation operator with eigenvalue $\Delta = n$. Let us consider the insertion of a half-BPS (local) operator at the origin of \mathbb{R}^4 . The operator-state correspondence associates to this operator on the plane a quantum state on $\mathbb{R} \times S^3$. Moreover, working in radial quantisation, the dilatation operator acting on the former becomes the Hamiltonian for the quantum theory on the latter. Let us now focus on a single scalar field, *e.g.* $Z(\vec{x}, t)$, with the intent of building protected operators out of it. Restricting to a single field, the R-symmetry group acts as an $U(1)$ abelian group, and we can label representations just by using their $U(1)$ charge, n . Furthermore, since $Z(\vec{x}, t)$ is a scalar, it has classical scaling dimension $\Delta = 1$. Its Taylor expansion around the origin of a R^3 slice at fixed time t is

$$Z(\vec{x}, t) = Z(0, t) + \sum_{k=1}^{\infty} \frac{1}{k!} [\partial_{\mu_1} \partial_{\mu_2} \cdots \partial_{\mu_k} Z(\vec{x}, t)]_{x=0} x^{\mu_1} x^{\mu_2} \cdots x^{\mu_k} \quad (1.2.4)$$

Since every derivative on the RHS contributes to the scaling dimension with one unit, the j -th term in the sum will have $\Delta = j + 1$. However, the R-charge of $Z(\vec{x}, t)$ is fixed to 1 on both sides of this equality. For protected operators, the R-charge must be equal to their scaling dimension. This means that, for constructing half-BPS operators, only the $Z(0, t)$ term on the RHS of (1.2.4) can be used. We conclude that to construct the half-BPS states in $\mathcal{N} = 4$ SYM one only needs the S-wave reduction of the decomposition of the complex scalar fields, $Z(0, t)$.

This is a one-matrix quantum mechanics. For example, the state

$$\text{Tr} \left(\underbrace{Z(0, t)^\dagger Z(0, t)^\dagger \cdots Z(0, t)^\dagger}_{n \text{ times}} \right) |\Omega\rangle \quad (1.2.5)$$

is a half-BPS supergravity mode on the S^5 internal space of $AdS_5 \times S^5$, where $|\Omega\rangle$ denotes the vacuum of the theory.

In the following sections we will focus on the one and two-matrix sector of the theory. We will count and construct all the local matrix invariants made with at most two complex matrices, give a finite N expression for their free field correlators and present evidences for what their gravity duals are.

1.2.1 One-matrix problem

We consider here the case in which all the n operators \mathcal{F} in (1.2.1) are the same complex scalar matrix, $X = \phi_1 + i\phi_2$. Since these fields live in the adjoint representation of $U(N)$, a gauge transformation by a unitary matrix U acts as

$$X \rightarrow UXU^\dagger \quad (1.2.6)$$

The matrix invariants are single- and multi-trace operators built with n copies of the same matrix X . Arguably the simplest way to construct an invariant out of n copies of the same matrix X is just to take the trace of their product. The result is a *single-trace* operator:

$$\mathcal{O} \sim \text{Tr}(X^n) \quad (1.2.7)$$

These operators are interesting to study as they belong to a half-BPS multiplet: supersymmetry protects their energy and they do not receive quantum corrections. As we stated in the previous section, their conformal dimension is $\Delta = n$ and they transform in the $[0, n, 0]$ representation of the $SU(4)$ R-symmetry group. We can also construct *multi-trace* invariant operators, by simply taking products of single-trace operators:

$$\mathcal{O} \sim \text{Tr}(X^{k_1})^{l_1} \text{Tr}(X^{k_2})^{l_2} \cdots, \quad \sum_j k_j l_j = n \quad (1.2.8)$$

One then asks what is the AdS/CFT dual of these operators. It has been shown that for $n \ll N$ they are dual to graviton excitations [9]. Single-trace operators (1.2.7) correspond to single particle bulk excitations. In this case the number of X fields, n , is interpreted as the angular momentum of the Kaluza-Klein graviton on the S^5 space. The construction of the Fock space in the gravity side is then immediate for these excitations, as we can simply associate to each single-trace operator a unique graviton mode. Multi-trace operators (1.2.8) are mapped to multi-particle graviton excitations. For $n = O(\sqrt{N})$ the gauge invariant (1.2.8) are dual to strings [12]. For $n = O(N)$ they are dual to *giant gravitons* [13]. These are gravitons with a very

large angular momentum: for large N the Myers effect [14] causes them to stretch into spherical D3 branes expanding into either the AdS or the compact S^5 space of the $AdS_5 \times S^5$ geometry. The brane action in this background, when a RR flux is turned on, admits stable BPS solutions - the giant gravitons. We will have more to say about these objects later in this section.

We will now focus on the problem of counting and computing correlators of single and multi trace operators, made with n copies of a single complex matrix X . An effective approach to both of these problems relies on permutations technology. As briefly stated in the previous section, we can specify a composite operator by contracting the upper indices of (1.2.1) with a suitable permutation of its lower indices. When all of the fields \mathcal{F} are taken to be the same, $\mathcal{F} = X$, this results in

$$\mathcal{O}_\sigma(X) = X_{i_{\sigma(1)}}^{i_1} \cdots X_{i_{\sigma(n)}}^{i_n} \quad (1.2.9)$$

where σ is a permutation of n elements, $\sigma \in S_n$. An equivalent way to write this equation is as follows:

$$\mathcal{O}_\sigma(X) = \text{Tr}_{V^{\otimes n}} (X^{\otimes n} \sigma) \quad (1.2.10)$$

Here the trace is taken over the tensor product space $V^{\otimes n}$, where V is the fundamental representation of $U(N)$. Operators written in the form of (1.2.10) are often said to be in the ‘trace basis’. The permutation σ acts as the map

$$\begin{aligned} \sigma : \quad V^{\otimes n} &\longrightarrow V^{\otimes n} \\ |i_1, i_2, \dots, i_n\rangle &\longmapsto |i_{\sigma(1)}, i_{\sigma(2)}, \dots, i_{\sigma(n)}\rangle \end{aligned} \quad (1.2.11)$$

with each $|i\rangle \in V$. Introducing the shorthand notations

$$|I\rangle = |i_1, \dots, i_n\rangle \in V_N^{\otimes n}, \quad \langle J| = \langle j_1, \dots, j_n| \in \bar{V}_N^{\otimes n}, \quad (1.2.12)$$

where \bar{V} is the antifundamental representation of $U(N)$, we can write the matrix elements of $X^{\otimes n}$ and σ as

$$(X^{\otimes n})_J^I = \langle I | X^{\otimes n} | J \rangle, \quad (\sigma)_J^I = \delta_{j_{\sigma(1)}}^{i_1} \delta_{j_{\sigma(2)}}^{i_2} \cdots \delta_{j_{\sigma(n)}}^{i_n} \quad (1.2.13)$$

Therefore, we have

$$(X^{\otimes n} \sigma)_J^I = (X^{\otimes n})_K^I (\sigma)_J^K = X_{k_1}^{i_1} \cdots X_{k_n}^{i_n} \delta_{j_{\sigma(1)}}^{k_1} \delta_{j_{\sigma(2)}}^{k_2} \cdots \delta_{j_{\sigma(n)}}^{k_n} = X_{i_{\sigma(1)}}^{i_1} \cdots X_{i_{\sigma(n)}}^{i_n} \quad (1.2.14)$$

Tracing the RHS above gives eq. (1.2.9).

Eq. (1.2.10) can also be interpreted diagrammatically. If we draw the matrix elements $(X^{\otimes n})_J^I$ and $(\sigma)_J^I$ as in Figure 1

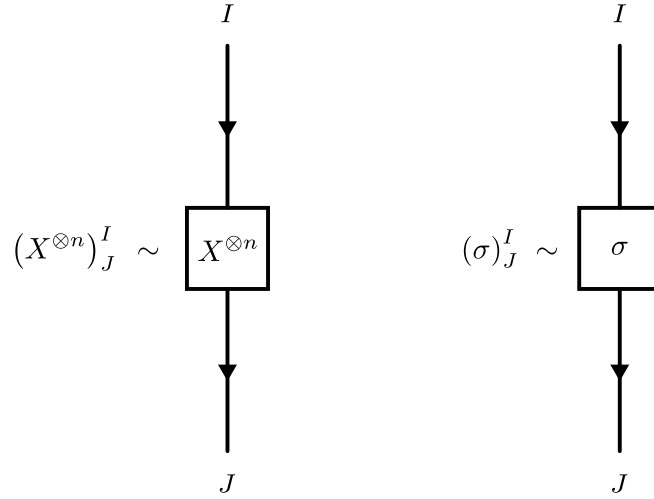

Figure 1: Diagrammatic description of the matrix elements of $X^{\otimes n}$, $\sigma \in S_n$.

then we can draw the operator $\mathcal{O}_\sigma(X)$, defined in (1.2.10), as in Figure 2. The horizontal bar in this figure denotes the tracing of the indices.

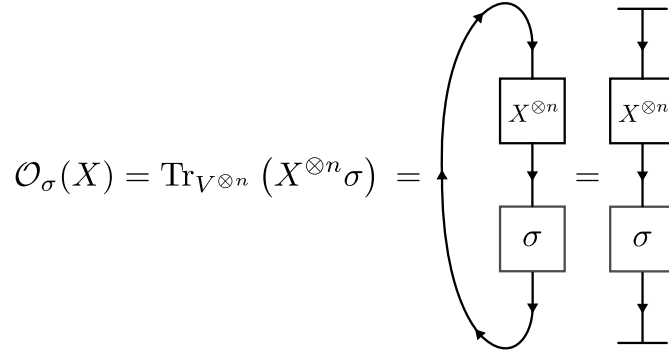

Figure 2: Diagrammatic description of $\mathcal{O}_\sigma(X)$, as defined in eq. (1.2.10). The horizontal bars in the diagram in the far RHS denote the identification of the indices, to form a trace.

Distinct σ related by conjugation, *i.e.* σ and $\gamma\sigma\gamma^{-1}$ for some $\gamma \in S_n$, give the same operator:

$$\mathcal{O}_\sigma(X) = \mathcal{O}_{\gamma\sigma\gamma^{-1}}(X) \quad (1.2.15)$$

This is most easily seen from the definition (1.2.10), where we just need to use the cyclicity of the trace and the fact that

$$[X^{\otimes n}, \gamma] = 0, \quad \sigma \in S_n \quad (1.2.16)$$

The latter equation is just the statement that the adjoint action of γ on a tensor product $X^{\otimes n}$ just reshuffles its constituent fields X . The equivalence relation (1.2.15) can also be seen pictorially as in Figure 3.

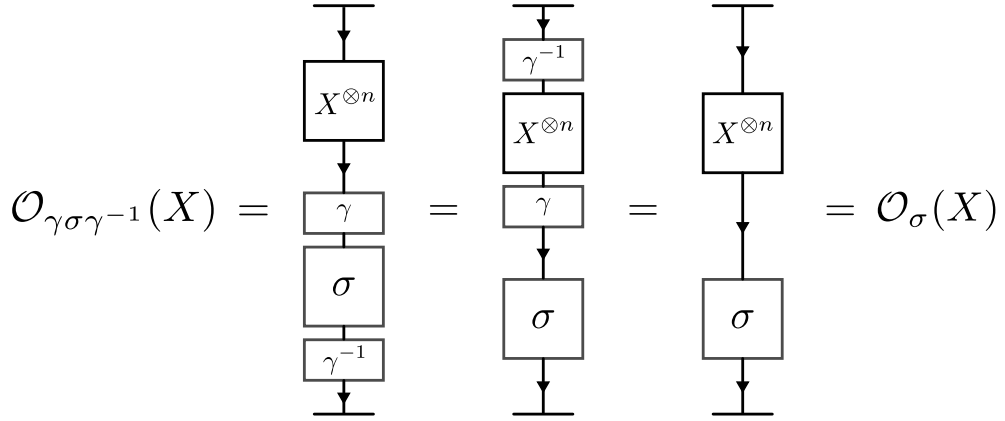

Figure 3: Diagrammatic interpretation of eq. (1.2.15).

Therefore, gauge invariants made with n complex matrices X are in a 1-1 correspondence with the conjugacy classes of S_n , rather than permutations $\sigma \in S_n$. Since in S_n there are $p(n)$ conjugacy classes, where $p(n)$ is the number of integer partitions of n , for fixed n we can form up to $p(n)$ invariants. This counting does not address the issue of finite N effects, that we will discuss later in this section. The large N generating function for the counting of these operators is therefore

$$\mathcal{Z}(x) = \sum_n p(n) x^n = \prod_{i=1}^{\infty} \frac{1}{1-x^i} \quad (1.2.17)$$

Aside from enumerating invariants, this permutation approach has been used to compute correlators in the free field theory. Let us then consider the correlator $\langle \mathcal{O}_{\sigma_1}(X)(x_1), \mathcal{O}_{\sigma_2}^\dagger(X)(x_2) \rangle$, where we made the spacetime dependence of the two matrix invariants explicit. Using Wick contractions we can decompose an n -point function into the sum of a product of propagators of the form

$$\langle X_j^i(x_1), X_l^{\dagger k}(x_2) \rangle = \frac{4\pi\lambda}{N} \frac{\delta_l^i \delta_j^k}{(x_1 - x_2)^2} \quad (1.2.18)$$

thus obtaining

$$\begin{aligned} & \langle X_{j_1}^{i_1}(x_1) X_{j_2}^{i_2}(x_1) \cdots X_{j_n}^{i_n}(x_1), X_{l_1}^{\dagger k_1}(x_2) X_{l_2}^{\dagger k_2}(x_2) \cdots X_{l_n}^{\dagger k_n}(x_2) \rangle \\ &= \left(\frac{4\pi\lambda}{N} \right)^n \frac{1}{(x_1 - x_2)^{2n}} \sum_{\gamma \in S_n} \delta_{l_{\gamma(1)}}^{i_1} \delta_{j_1}^{k_{\gamma(1)}} \delta_{l_{\gamma(2)}}^{i_2} \delta_{j_2}^{k_{\gamma(2)}} \cdots \delta_{l_{\gamma(n)}}^{i_n} \delta_{j_n}^{k_{\gamma(n)}} \end{aligned} \quad (1.2.19)$$

From here it follows that, using the definition (1.2.9)

$$\langle \mathcal{O}_{\sigma_1}(X)(x_1), \mathcal{O}_{\sigma_2}^\dagger(X)(x_2) \rangle = \left(\frac{4\pi\lambda}{N} \right)^n \frac{1}{(x_1 - x_2)^{2n}} \sum_{\gamma \in S_n} \sum_{\gamma \in S_n} \text{Tr}_{V^{\otimes n}} (\sigma_1 \gamma \sigma_2 \gamma^{-1}) \quad (1.2.20)$$

Since the spacetime dependence in these correlators is trivial, we will drop it from our equations, assuming it always implicit. We will also omit the coupling constant term, $\frac{4\pi\lambda}{N}$, as it can always be easily reinstated. The correlator above would then have the notationally simpler form

$$\langle \mathcal{O}_{\sigma_1}(X), \mathcal{O}_{\sigma_2}^\dagger(X) \rangle = \sum_{\gamma \in S_n} \text{Tr}_{V^{\otimes n}} (\gamma \sigma_1 \gamma^{-1} \sigma_2^{-1}) \quad (1.2.21)$$

Using the diagrammatic description of the Wick contractions (1.2.19) shown in Figure 4

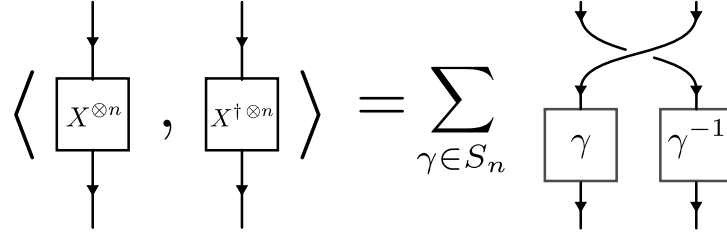

Figure 4: Diagrammatic description of the Wick contractions (1.2.19).

we can interpret the correlator (1.2.21) as in Figure 5.

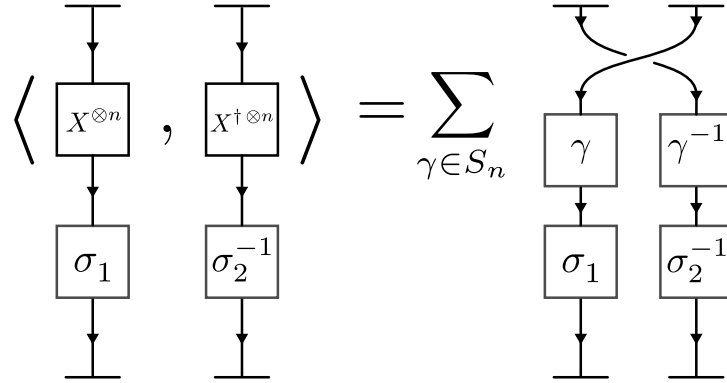

Figure 5: The correlator (1.2.21) in diagrammatic notation.

Now by using the relation

$$\text{Tr}_{V^{\otimes n}} (\sigma) = N^{C[\sigma]} \quad (1.2.22)$$

where $C[\sigma]$ is the number of cycles in the permutation σ , we can rewrite eq. (1.2.21) as

$$\begin{aligned} \langle \mathcal{O}_{\sigma_1}(X), \mathcal{O}_{\sigma_2}^\dagger(X) \rangle &= \sum_{\gamma \in S_n} N^{C[\gamma \sigma_1 \gamma^{-1} \sigma_2^{-1}]} \\ &= \sum_{\alpha, \gamma \in S_n} N^{C[\alpha]} \delta(\gamma \sigma_1 \gamma^{-1} \sigma_2^{-1} \alpha) \end{aligned} \quad (1.2.23)$$

where $\delta(\sigma)$ is the symmetric group delta, defined to be one iff $\sigma = 1$ and zero otherwise.

Interestingly, this formula has also an interpretation in terms of the counting of branched covers with three branch points over the sphere \mathbb{P}^1 (see for example [15] and references therein). A few comments are now in order. This correlator is N -exact, meaning it contains all the powers of N . The planar limit is recovered by taking the leading power of N , which is given by the $\alpha = 1$ term in the sum on the RHS. This is because the identity permutation has the highest number of cycles, $C[1] = n$. Therefore

$$\left\langle \mathcal{O}_{\sigma_1}(X), \mathcal{O}_{\sigma_2}^\dagger(X) \right\rangle_{\text{planar}} = N^n \sum_{\gamma \in S_n} \delta(\gamma \sigma_1 \gamma^{-1} \sigma_2^{-1}) \quad (1.2.24)$$

The RHS above is zero unless σ_1 and σ_2 are in the same conjugacy class. Since matrix invariants are labelled by conjugacy classes, rather than permutations, we can say that the trace basis (1.2.10) is orthogonal in the planar limit. However, we can now appreciate how the *planar limit* and the *large N limit*, which are sometimes used interchangeably, are in fact quite different. Consider the Next to Leading Order (NLO) correction of (1.2.23). It is

$$\left\langle \mathcal{O}_{\sigma_1}(X), \mathcal{O}_{\sigma_2}^\dagger(X) \right\rangle_{\text{N.L.O.}} = \sum_{\alpha \in \text{Trasp.}} \sum_{\gamma \in S_n} N^{n-1} \delta(\gamma \sigma_1 \gamma^{-1} \sigma_2^{-1} \alpha) \quad (1.2.25)$$

Here *Trasp.* is the set of transpositions of n elements. If n approaches order N , the combinatorial factors $\sum_{\alpha \in \text{Trasp.}} \sum_{\gamma \in S_n} \delta(\gamma \sigma_1 \gamma^{-1} \sigma_2^{-1} \alpha)$ in (1.2.25) become very large, overpowering the suppression by powers of $1/N^2$ of non-planar diagrams [16]. As such, this contribution can not be discarded. The same consideration also holds for the other subleading orders. Therefore, the trace basis (1.2.10) is not diagonal, even in the large N limit.

In the introduction we stated that matrix invariants made with $n = O(N)$ copies of the matrix X are dual to giant gravitons. It becomes now apparent that GIOs built with a *fixed* number of traces, by themselves, cannot be dual to the latter. It is therefore important to find a basis which diagonalises these matrix invariants. Another reason why it is desirable to find another description of these states are finite N constraints. The set of $\mathcal{O}_\sigma(X)$, $\sigma \in S_n$, form in fact a suitable basis only for $n \leq N$. For $n > N$ the Cayley-Hamilton theorem implies that every element of the form $\text{Tr}(X^{N+k})$, $k \in \mathbb{N}_+$ can be decomposed in a sum of multi-trace operators.

The way around both these problems has been resolved in [17]. The idea is to pass from the permutation-based description that we have discussed so far to its *dual* description, which is expressed in terms of representation theory data. This map is referred to as a Fourier transform on the symmetric group. Instead of labelling an operator by a conjugacy class of S_n , as in (1.2.10), we will label it with a Young diagram made with n boxes. Such diagrams are in a 1-1 correspondence with irreducible representations¹ of S_n . This leads to the construction of operators in the half-BPS sector parametrised by Young diagrams [17, 18]. Operators built with

¹Since in this thesis we will not consider reducible representations, we will sometimes refer to an irreducible representation simply as a representation.

this formalism are called Schur operators, and are defined as:

$$\mathcal{O}_R(X) = \frac{1}{n!} \sum_{\sigma \in S_n} \chi_R(\sigma) \mathcal{O}_\sigma(X) \quad (1.2.26)$$

where $\chi_R(\sigma)$ is the ordinary character of the representation R of S_n . The set of operators of the form (1.2.26) is sometimes called the ‘Young basis’, or ‘representation basis’. In [17] it was shown that the operators in (1.2.26) diagonalise the pairing

$$\langle \mathcal{O}_R(Z), \mathcal{O}_S^\dagger(Z) \rangle = \delta_{R,S} \frac{n! \text{Dim}(R)}{d_R} \quad (1.2.27)$$

Here R, S are both representations of S_n , $\text{Dim}(R)$ is the dimension of the $U(N)$ representation R and d_R is the dimension of the S_n representation R . We will continue to use this convention throughout this thesis.

There are a number of other features of Schur operators that help us in mapping them to their gravity duals. In the founding paper [13], it was argued that giant gravitons extend to a size of radius proportional to the square of their angular momentum. If the giant is extending in the 5-sphere of the $AdS_5 \times S^5$ space, its size has to be less than the one of the S^5 . This is the manifestation of the stringy exclusion principle [19]: the particle cannot be bigger than the space that contains it. This constraint therefore imposes a boundary on the angular momentum of the graviton, which on the gauge theory side translates into a boundary for the R-charge of the dual operators. Schur operators $\mathcal{O}_R(X)$ associated to completely antisymmetric representations have the constraint that the length of the first column of the representation R , $c_1(R)$, must be at most equal to the rank N of the gauge group, $c_1(R) \leq N$. In [16] the authors showed that this boundary perfectly matches the cut-off of giant gravitons. This is a strong suggestion that Schur operators of totally antisymmetric representations are dual to spherical giants. On the other hand, since the anti-de Sitter space of the background is unbounded, AdS gravitons have no size constraint to satisfy. It is then natural to associate them to the dual Schur operators whose representation is totally symmetric.

Operators whose Young diagrams have order one long rows and order one long columns are mapped to a system of AdS and spherical giants respectively [17]. Since the length of the first column (row) of the Young diagram parametrising the giant is proportional to its angular momentum, and since the angular momentum determines the size of the giant, a Young diagram with order one long columns (rows) of the same length is mapped to a system of AdS (spherical) giants whose worldvolumes overlap. On the other hand, Young diagrams with rows (columns) of different length are mapped to giants with separated worldvolumes. In this multi-particle context, the constraint $c_1(R) \leq N$ imposes a bound on the number of AdS giant gravitons. The interpretation of this limit in the gravity side is given in terms of the Ramond-Ramond 5-form flux originating at the centre of the AdS. When the threshold of N AdS giants is reached, adding a further giant would reverse the sign of the flux, causing the collapse of some of the branes [20]. This argument shows that any system with more than N AdS giants is not stable.

Three point functions of these half-BPS operators are known as well [17]. Consider then three operators of the form given in (1.2.26), $\mathcal{O}_R(X)$, $\mathcal{O}_S(X)$, $\mathcal{O}_T(X)$. Here R , S and T are Young diagrams of S_m , S_n and S_{m+n} . Notice that we do not require m and n to be equal. The computation of [17] gives

$$\langle \mathcal{O}_R(X) \mathcal{O}_S(X) \mathcal{O}_T^\dagger(X) \rangle = g(R, S; T) \frac{(m+n)! \text{Dim}(T)}{d_T} \quad (1.2.28)$$

The key quantity on the RHS above is the *Littlewood-Richardson* (LR) coefficient $g(R, S; T)$. This is the number of times the representation T appears in the tensor product of representations $R \otimes S$ [11, 21–24]. LR coefficients will be reviewed in Appendix C.2. This is essentially the quantity that controls the mixing of the representations R and S to give T , and it will be a central element of this thesis. They are all positive integers, and can be expressed in terms of the Unitary group integral

$$g(R, S; T) = \int \mathcal{D}U \chi_R(U) \chi_S(U) \chi_T(U^\dagger) \quad (1.2.29)$$

where $\mathcal{D}U$ is the Haar measure and the $\chi_R(U)$ are the ordinary symmetric group characters. Restoring the spacetime dependence in (1.2.28) gives

$$\langle \mathcal{O}_R(X)(x_1) \mathcal{O}_S(X)(x_2) \mathcal{O}_T^\dagger(X)(x_3) \rangle = g(R, S; T) \frac{(m+n)! \text{Dim}(T)}{d_T |x_1 - x_3|^m |x_2 - x_3|^n} \quad (1.2.30)$$

Notice that the denominator is missing the term $(x_1 - x_2)^{\Delta_1 + \Delta_2 - \Delta_3}$. This is because the \mathcal{O} 's are protected operators, and their conformal dimension do not receive quantum corrections, so that $\Delta_1 = m$, $\Delta_2 = n$ and $\Delta_3 = m + n$ exactly. Therefore $\Delta_1 + \Delta_2 - \Delta_3 = 0$ at all orders in perturbation theory.

In [17] it is also given the form for the generic k point extremal correlators. The result of the computation is very similar to the RHS of (1.2.28), with the $g(R, S; T)$ coefficient replaced by the generalised LR coefficient

$$g(R_1, R_2, \dots, R_k; R) = \sum_{S_1, S_2, \dots, S_{k-2}} g(R_1, R_2; S_1) g(S_1, R_3; S_2) \cdots g(S_{k-2}, R_k; R) \quad (1.2.31)$$

We only state these results without proving them, for a detailed derivation see [17].

1.2.2 Two-matrix problem

In this section we consider invariants built from two types of matrices, say m copies of X and n copies of Y . We are interested in holomorphic polynomials in two complex matrices (X, Y) that are invariant under a $U(N)$ gauge symmetry that acts as

$$(X, Y) \rightarrow (UXU^\dagger, UYU^\dagger) \quad (1.2.32)$$

Like in the one-matrix problem, matrix invariants will be single- and multi-traces polynomial

in the X, Y matrices. These operators are generally not protected. It has been proposed that operators of this form are AdS dual to excitations of giant gravitons [11]. We stated earlier that a giant graviton is constructed by taking $n = O(N)$ copies of the same matrix, *e.g.* X . Consider now a matrix invariant made with a large number $m = O(N)$ of X -type matrices and a few Y -type matrices, $n = O(\sqrt{N})$. The latter can be considered as ‘impurities’, and can be interpreted as open strings emanating from the giant graviton, which is in turn generated by the X matrices. The endpoint of the open string attached to the giant acts as a point-like charge for its world-volume theory. Since the net charge of a giant has to be null, Gauss law implies that for every string ending on the giant, a string must be leaving it. This proposal first appeared in [11], where the author tested it by showing that the counting of the states satisfying the Gauss constraint on the gravity side matches the counting of matrix invariants built with two matrices. We will now describe the construction of these matrix invariants. The procedure closely follows the one discussed in the one-matrix problem case. We define $\mathcal{O}_\sigma(X, Y)$ as

$$\mathcal{O}_\sigma(X, Y) = \text{Tr}_{V^{\otimes(m+n)}} (X^{\otimes m} \otimes Y^{\otimes n} \sigma) \quad (1.2.33)$$

which we represent as in Figure 6.

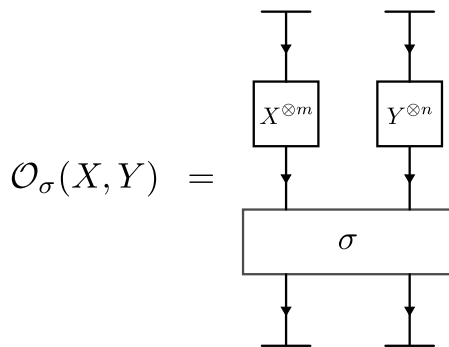

Figure 6: Diagrammatic description of $\mathcal{O}_\sigma(X, Y)$, as defined in eq. (1.2.33).

Permutations related by conjugation under the subgroup $S_m \times S_n$ label the same matrix invariant:

$$\mathcal{O}_\sigma(X, Y) = \mathcal{O}_{\gamma\sigma\gamma^{-1}}(X, Y), \quad \gamma \in S_m \times S_n \quad (1.2.34)$$

This is a generalisation of the equivalence (1.2.15) to the two-matrix case. The key difference is that the permutation γ is an element of the subgroup $S_m \times S_n \subset S_{m+n}$, rather than the full group S_{m+n} . This identity is best understood pictorially as in Figure 7.

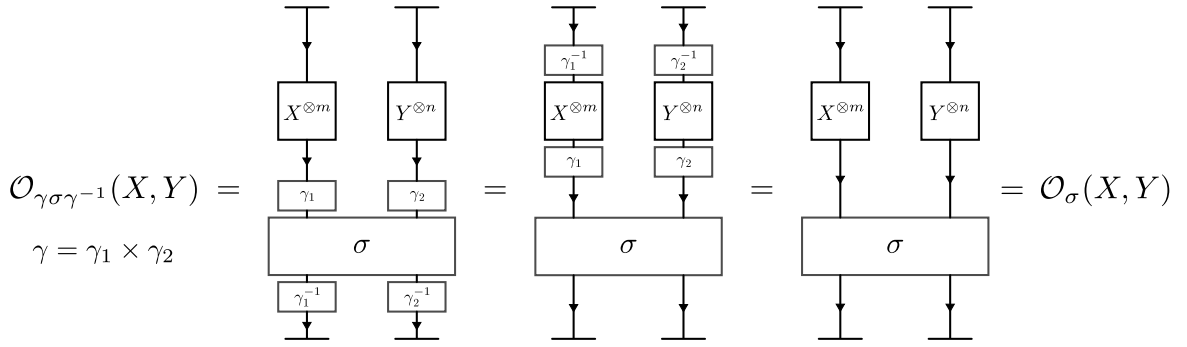

Figure 7: Conjugate permutations under the subgroup $S_m \times S_n$ label the same matrix invariant. In the picture, $\gamma = \gamma_1 \times \gamma_2$.

In the large N limit, where the only constraint is expressed by eq. (1.2.33), the counting of matrix gauge invariant is expressed by [25]

$$\mathcal{Z}(x, y) = \prod_{i=1}^{\infty} \frac{1}{1 - x^i - y^i} = \sum_{m, n=0}^{\infty} x^m y^n \left(\# \text{ of matrix invariants with } m, n \text{ copies of } X, Y \right) \quad (1.2.35)$$

Using Wick contractions, and suppressing the coupling constant and the spacetime dependence of the operators, we can write the free field correlator as

$$\begin{aligned} \left\langle \mathcal{O}_{\sigma_1}(X, Y), \mathcal{O}_{\sigma_2}^\dagger(X, Y) \right\rangle &= \sum_{\gamma \in S_m \times S_n} \text{Tr}_{V^{\otimes(m+n)}} (\sigma_1 \gamma \sigma_2^{-1} \gamma^{-1}) \\ &= \sum_{\alpha \in S_{m+n}} \sum_{\gamma \in S_m \times S_n} N^{C[\alpha]} \delta(\sigma_1 \gamma \sigma_2^{-1} \gamma^{-1} \alpha) \end{aligned} \quad (1.2.36)$$

This equation should be compared to the one-matrix case equivalent, eq. (1.2.23). The difference is only in the sum over the permutation γ , which, as in eq. (1.2.34), is now restricted to the subgroup $S_m \times S_n \subset S_{m+n}$.

As we did for the one-matrix problem, we can now use the Fourier transform on the symmetric group to map the operators in (1.2.33) to their respective dual, which are expressed in terms of representation theory quantities. In this case, however, we will need more than a single Young diagram to unequivocally specify a GIO. Given that the permutation basis was expressed in terms of the embedding $S_m \times S_n \subset S_{m+n}$, it is expected that the representation basis will know about this reduction as well. Let us take an irreducible representation $V_R^{S_{m+n}}$ of S_{m+n} and to restrict S_{m+n} to its subgroup $S_m \times S_n \subset S_{m+n}$. $V_R^{S_{m+n}}$ becomes then reducible, and decomposes as

$$V_R^{S_{m+n}} \Big|_{S_m \times S_n} \simeq \bigoplus_{R_1, R_2} V_{R_1}^{S_m} \otimes V_{R_2}^{S_n} \otimes V_{R_1, R_2}^R \quad (1.2.37)$$

where $V_{R_1}^{S_m}$ and $V_{R_2}^{S_n}$ are irreducible representations of S_m and S_N respectively. V_{R_1, R_2}^R is the

multiplicity vector space: it is in fact possible that the same representation $R_1 \otimes R_2$ appears more than once in the decomposition of R , and this vector space keeps track of these possible iterations. The dimension of the multiplicity vector space v is given by the LR coefficient $g(R_1, R_2; R)$, already introduced in the previous section: $\dim(V_{R_1, R_2}^R) = g(R_1, R_2; R)$.

In the permutation basis description of the two-matrix sector, matrix invariants were labelled by $S_m \times S_n$ conjugacy classes, rather than S_{m+n} . It is then natural to think that the representation basis will be built with the vector space decomposition on the RHS of (1.2.37). The application of this thinking leads to *restricted Schur operators* [11, 22–24]. These are labelled by three Young diagrams and a pair of multiplicity labels: a Young diagram R_1 with m boxes, a Young diagram R_2 with n boxes and a third diagram R with $m+n$ boxes. The two multiplicity labels i and j each run over a space of dimension equal to $g(R_1, R_2; R)$. The restricted Schur operators are written as

$$\mathcal{O}_{R_1, R_2; i, j}^R(X, Y) = \frac{1}{m!n!} \sum_{\sigma \in S_{m+n}} \chi_{R_1, R_2; i, j}^R(\sigma) \mathcal{O}_\sigma(X, Y) \quad (1.2.38)$$

$\chi_{R_1, R_2; i, j}^R(\sigma)$ is the restricted character, that we define as follows. Let $D^R(\sigma)$ be the matrix realisation of the permutation σ in the representation R of S_{m+n} . Let $\{|R_1, l_1\rangle\}$ be a basis for the irrep $V_{R_1}^{S_m}$ of S_m , and $\{|R_2, l_2\rangle\}$ be a basis for the irrep $V_{R_2}^{S_n}$ of S_n . Also let $|i\rangle$ and $|j\rangle$ be states in the multiplicity vector space V_{R_1, R_2}^R . The state $|R_1, l_1\rangle \otimes |R_2, l_2\rangle \otimes |i\rangle \equiv |R_1, l_1; R_2, l_2; i\rangle$ is then a natural basis element of the vector space on the RHS of (1.2.37). Aside from a normalisation constant, we write the restricted characters as

$$\chi_{R_1, R_2; i, j}^R(\sigma) = \sum_{l_1, l_2} \langle R_1, l_1; R_2, l_2; i | D^R(\sigma) | R_1, l_1; R_2, l_2; j \rangle \quad (1.2.39)$$

If $|i\rangle = |j\rangle$, these objects are just the trace of $D^R(\sigma)$ over the $V_{R_1}^{S_m} \otimes V_{R_2}^{S_n}$ vector space. If instead $|i\rangle \neq |j\rangle$, we are evaluating $D^R(\sigma)$ on a copy of $V_{R_1}^{S_m} \otimes V_{R_2}^{S_n} \subset V_R^{S_{m+n}}|_{S_m \times S_n}$, labelled i , and then taking the pairing of the result on the basis of a *different* copy of $V_{R_1}^{S_m} \otimes V_{R_2}^{S_n} \subset V_R^{S_{m+n}}|_{S_m \times S_n}$, labelled j (see for example the discussion in [26]). For this reason, another way to write them is

$$\chi_{R_1, R_2; i, j}^R(\sigma) = \chi_R(P_{R_1, R_2; i, j}^R D^R(\sigma)) \quad (1.2.40)$$

Here if $i = j$, $P_{R_1, R_2; i, j}^R$ is the projector of the representation $V_R^{S_{m+n}}|_{S_m \times S_n}$ on the i -th copy of the representation $V_{R_1}^{S_m} \otimes V_{R_2}^{S_n} \subset V_R^{S_{m+n}}|_{S_m \times S_n}$, whereas if $i \neq j$ it is an intertwining operator mapping different copies of $V_{R_1}^{S_m} \otimes V_{R_2}^{S_n}$, labelled by i and j , one onto another. We will have more to say about these multiplicities later in the later chapters of this thesis, especially in Chapter 4.

It can be shown that the two point functions of gauge invariant operators in the two-matrix sector are diagonalized by operators constructed using representation bases, such as the one in (1.2.38). This was done with the Brauer basis in [27], with the $U(2)$ covariant basis in [28, 29] and with the restricted Schur basis in [30, 31]. The key fact is that by using the Fourier trans-

formation, which relates functions on a group to matrix elements of irreducible representations, nice orthogonal bases of functions on these equivalence classes can be found. In mathematics, in the context of compact groups this is known as the Peter-Weyl theorem. In the context of finite groups, this follows from the Schur orthogonality relations.

On the other hand, the reason for the efficacy of permutation groups in enumeration of gauge invariant operators is Schur-Weyl duality. This states that the tensor product of n copies of the fundamental of $U(N)$ decomposes into a direct sum of irreps of $S_n \times U(N)$

$$V_N^{\otimes n} \simeq \bigoplus_{\substack{R \vdash N \\ c_1(R) \leq N}} V_R^{S_n} \otimes V_R^{U(N)} \quad (1.2.41)$$

Each summand is labelled by a Young diagram, and the Young diagrams are constrained to have no more than N rows, equivalently the first column $c_1(R)$ is no greater than N . This uses the fact that Young diagrams are used to classify representations of S_n as well as representations of $U(N)$. This is useful in the permutation approach to gauge invariant operators, because it says that once we have organised operators according to representation data for S_n , it is easy to implement finite N constraints. In the one-matrix problem, the single Young diagram label R is cut-off at N , $c_1(R) \leq N$. This leads directly to the connection between the stringy exclusion principle for giant gravitons and Young diagrams [13, 16, 17, 19]. In the two-matrix problem, the Young diagram R is cut-off at $c_1(R) \leq N$, which implies cut-offs for R_1, R_2 . Within $\mathcal{N} = 4$ SYM, perturbations of half-BPS giant graviton operators have been studied and integrability at one-loop [32, 32–36] and beyond has been established. The two-matrix problem can also be approached using the walled Brauer algebra $B_N(m, n)$ and its representation theory [27]. A third way to enumerate two-matrix invariants, also based on permutations but involving Clebsch-Gordan multiplicities of S_n , keeps the $U(2)$ global symmetry manifest [28, 29].

The restricted Schur and covariant basis results have been extended beyond $\mathcal{N} = 4$ SYM to the sector of holomorphic operators in general quiver gauge theories [1, 26, 36–39] which have been shown to include sectors related to generalized oscillators [40]. Aspects involving Frobenius algebras have been studied in [41].

1.3 Generalisation to quiver gauge theories

As we reviewed in the previous section, finite N aspects of AdS/CFT have motivated the study of multi-matrix sectors of $\mathcal{N} = 4$ SYM, associated with different BPS sectors of the theory. These multi-matrix systems are also of interest purely from the point of view of supersymmetric gauge theory and their moduli spaces (*e.g.* [42]). These studies focused on the counting of gauge-invariant operators, an inner product related to 2-point functions and higher point functions for large N as well as at finite N . The connection between $U(N)$ gauge invariants and permutations was a central theme as well as representation theory of the permutation groups. The studies were extended beyond $\mathcal{N} = 4$ SYM to gauge theories such as ABJM [43] and the conifold [44–47]. In [26] these problems on counting and inner product were considered for general

quiver gauge theories. These theories, often arising in the context of 3-branes transverse to 6-dimensional singular Calabi-Yau, are associated with directed graphs, i.e. collections of nodes with directed edges between them [48]. The gauge group of the theory is a product of unitary groups, one unitary group for each node. The directed edges correspond to bi-fundamental matter fields, which transform according to the anti-fundamental representation of the gauge group corresponding to the starting node and the fundamental of the ending node. In the context of AdS/CFT, adding matter to $\mathcal{N} = 4$ SYM introduces flavour symmetries [49–53]. Typically, the added matter transforms in fundamental and anti-fundamental representations of these flavour symmetries. Matrix invariants in flavoured gauge theories do not need to be invariant under the flavour group: on the contrary, they have free indices living in the representation carried by their constituent fields. In this thesis, we consider a general class of flavoured free gauge theories parametrised by a quiver. A quiver is a directed graph comprising of round nodes (gauge groups) and square nodes (flavour groups). The directed edges which join the round nodes corresponds to fields transforming in the bi-fundamental representation of the gauge group, as illustrated in subsection 1.4. Edges stretching between a round and a square node correspond to fields carrying a fundamental or antifundamental representation of the flavour group, depending on their orientation. We will call them simply quarks and antiquarks.

It was shown in [26] that the quiver, besides being a compact way to encode all the gauge groups and the matter content of the theory, is a powerful computational tool for correlators of gauge invariants. In that paper a generalisation of permutation group characters, called *quiver characters*, was introduced, involving branching coefficients of permutation groups in a non-trivial way. Obtaining the quiver character from the quiver diagram involves splitting each gauge node into *two* nodes, called positive and negative nodes. The first one collects all the fields coming into the original node, while the second one collects all the fields outgoing from the original node. A new line is added to join the positive and the negative node of the split-node diagram. Each edge in this modified quiver is decorated with appropriate representation theory data, as will be explained in the following sections. The properties of these characters, which have natural pictorial representations, allowed the derivation of counting formulae for the gauge invariants and expressions for the correlation functions.

In the first part of this thesis we study correlation functions of holomorphic and anti-holomorphic gauge invariant operators in quiver gauge theories with flavour symmetries, in the zero coupling limit. We will explicitly construct the operators and compute the free field two and three point functions. These have non-trivial dependences on the structure of the operators and on the ranks of the gauge and flavour symmetries. Our results are exact in the ranks, and their expansions contain information about the planar limit as well as all order expansions. The techniques we use build on earlier work exploiting representation theory techniques in the context of $\mathcal{N} = 4$ SYM [11, 17, 18, 22–24, 27–29, 54, 55]. The zero coupling results contain information about a singular limit from the point of view of the dual AdS. For special BPS sectors, where non-renormalisation theorems are available, the representation theory methods have made contact with branes and geometries in the semiclassical AdS background. These representation

theoretic studies were extended beyond $\mathcal{N} = 4$ SYM to ABJM [43] and conifolds [44, 56–58]. The case of general quivers was studied in [26] and related work on quivers has since appeared in [59–62].

As a way to understand the existence of the different bases in the multi-matrix problems, [54] conducted a detailed study of enhanced symmetries in the free limit of Yang Mills theories. The authors showed that Casimir-like elements constructed from Noether charges of these enhanced symmetries can be used to understand these different bases. Different sets of these Casimir-like charges each consist of mutually commuting simultaneously diagonalizable operators, which associate the labels of the basis with eigenvalues of Casimir-like charges. Thus there is a set of Casimir-like elements for the restricted Schur basis, another set for the covariant basis and yet another set for the Brauer basis. The enhanced symmetries themselves take the form of products of unitary groups, but the action of these Casimirs on gauge invariant operators can be related, through applications of Schur-Weyl duality, to the algebraic structure of certain algebras constructed from the equivalence classes of permutations or of Brauer algebra elements discussed above. The discussion of charges which identify matrix invariants for general classical groups has been given using a different approach in [63]. While a uniform treatment of the Young diagram labels has been achieved, a treatment of the multiplicity labels running over Littlewood-Richardson coefficients in that approach remains an interesting open problem.

1.4 Definitions and framework

In this thesis we consider free quiver gauge theories with gauge group $\prod_{a=1}^n U(N_a)$ and flavour symmetry of the general schematic form $\prod_{a=1}^n U(F_a) \times U(\bar{F}_a)$. Specifically, to work in the most general configuration, we choose to focus our attention to the subgroup $\prod_{a=1}^n [\times_{\beta} U(F_{a,\beta}) \times_{\gamma} U(\bar{F}_{a,\gamma})]$ of the flavour symmetry where $F_a = \sum_{\beta} F_{a,\beta}$ and $\bar{F}_a = \sum_{\gamma} \bar{F}_{a,\gamma}$. This more general flavour symmetry, where the $U(F_a) \times U(\bar{F}_a)$ is broken to a product of unitary groups for the quarks and anti-quarks, is likely to be useful when interactions are turned on. Our calculations work without any significant modification for this case of product global symmetry, hence we will work in this generality.

To recover the results for the global symmetry $U(F_a) \times U(\bar{F}_a)$ it is enough to drop the β, γ labels from all the equations that we are going to write. The constraint $F_a = \bar{F}_a$ solves chiral gauge anomaly conditions. As a last remark, notice that strictly speaking the global symmetry of the free theory contains only the determinant one part $S(U(F_{a,1}) \times U(F_{a,2}) \times \cdots \times U(F_{a,M_a}) \times U(\bar{F}_{a,1}) \times \cdots \times U(\bar{F}_{a,\bar{M}_a}))$. This means that, although for simplicity we write $\prod_{a=1}^n [\times_{\beta} U(F_{a,\beta}) \times_{\gamma} U(\bar{F}_{a,\gamma})]$ as the global symmetry, all the states we will write are neutral under the $U(1)$ which acts with a phase on all of the chiral fields and with the opposite phase on all of the anti-chiral fields. This $U(1)$ is part of the $U(N_a)$ gauge symmetry.

We now introduce the diagrammatic notation for the quivers. We follow the usual convention according to which round nodes in the quiver correspond to gauge groups, whereas square nodes correspond to global symmetries. Fields leaving gauge node a and arriving at gauge node b are denoted by $\Phi_{ab,\alpha}$, and transform in the antifundamental representation \bar{V}_{N_a} of $U(N_a)$ and

the fundamental representation V_{N_b} of $U(N_b)$. The third label α takes values in $\{1, \dots, M_{ab}\}$, and is used to distinguish between M_{ab} different fields that transform in the same way under the gauge group. We can think of each $\Phi_{ab,\alpha}$ as a map

$$\Phi_{ab,\alpha} : V_{N_a} \rightarrow V_{N_b} \quad (1.4.1)$$

At every gauge node a we allow M_a different families of quarks $\{Q_{a,\beta}, \beta = 1, \dots, M_a\}$ transforming in the antifundamental of $U(N_a)$ and \bar{M}_a different families of antiquarks $\{\bar{Q}_{a,\gamma}, \gamma = 1, \dots, \bar{M}_a\}$, transforming in the fundamental of $U(N_a)$. As for the field Φ , the greek letters β and γ distinguish the multiplicities of the quarks and antiquarks respectively. $U(F_{a,\beta})$ and $U(\bar{F}_{a,\gamma})$ represent the flavour group of the quark $Q_{a,\beta}$ and of the antiquark $\bar{Q}_{a,\gamma}$ respectively. Figure 8 explicitly show this field configuration for one node a of the quiver. Table 1 summarises instead all the gauge and flavour group representations carried by every field in the quiver.

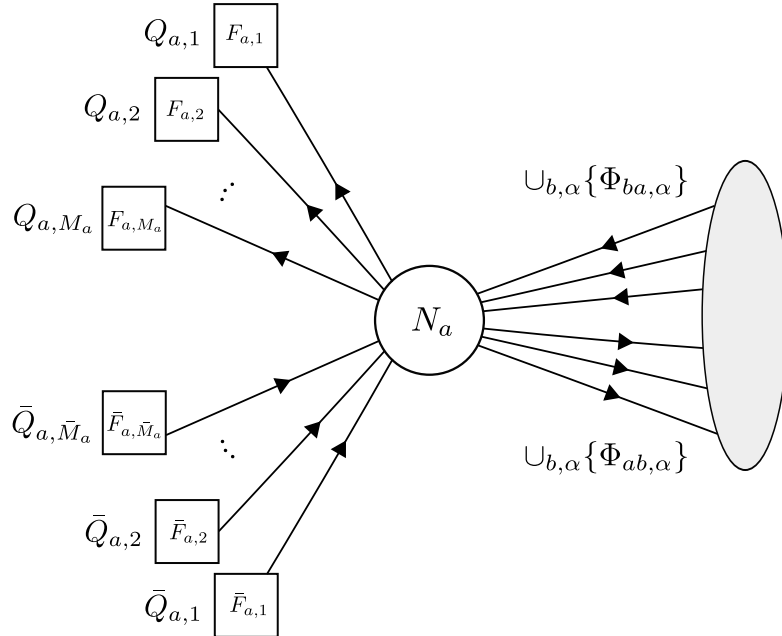

Figure 8: Pictorial representation of the fundamental fields (oriented edges), flavour group (square nodes) for a single gauge node labelled a .

	$U(N_a)$	$U(N_b)$	$U(F_{a,\beta})$	$U(\bar{F}_{a,\gamma})$
$\Phi_{ab,\alpha}$	$\bar{\square}$	\square	$\mathbf{1}$	$\mathbf{1}$
$\Phi_{aa,\alpha}$	Adj	$\mathbf{1}$	$\mathbf{1}$	$\mathbf{1}$
$Q_{a,\beta}$	$\bar{\square}$	$\mathbf{1}$	\square	$\mathbf{1}$
$\bar{Q}_{a,\gamma}$	\square	$\mathbf{1}$	$\mathbf{1}$	$\bar{\square}$

Table 1: Gauge and flavour group representations carried by $\Phi_{ab,\alpha}$, $Q_{a,\beta}$ and $\bar{Q}_{a,\gamma}$. \square , $\bar{\square}$ and $\mathbf{1}$ are respectively the fundamental, antifundamental and trivial representations of the corresponding group.

Chapter 2

Counting Functions and the Cartier-Foata Monoid

In this chapter we will derive the counting function for the number of Quiver Restricted Schur Polynomials, both for finite and large N . We will also establish a connection between the counting of quiver gauge theory operators and a word counting problem associated with the quiver graph. This creates a link between gauge invariant operators of quiver theories and the mathematics of Cartier-Foata monoids [64, 65]. The latter is expressed here in terms of a word counting problem where the letters correspond to loops on a graph, with partial commutation relations

The starting point of our derivation is the group integral formula for counting gauge invariant operators [66, 67]. The group integrals over $U(N)$ are done by using character expansions. These character expansions introduce characters of permutation groups, because of the Schur-Weyl duality [68, 69] link between unitary and symmetric groups. The finite N counting formulae admit significant simplifications in the limit of large N . At finite N , the counting involves sums over Young diagram labels. The sizes of the Young diagrams are related to the sizes of the local operators. When these sizes are small compared to the ranks, the Young diagram sums run over complete sets of representations of symmetric groups. This allows the use of formulae from Fourier transformation over finite groups such as

$$\delta(\sigma) = \frac{1}{m!} \sum_R d_{R\chi R}(\sigma) \quad (2.0.1)$$

The delta function is 1 if σ is the identity permutation in S_m - symmetric group of all permutations of m objects - and zero otherwise. The result is that the counting formulae can be expressed in terms of sums over multiple permutations, related by delta function constraints. These sums over permutations can be converted into sums over partitions, described by an infinite sequence of integers p_1, p_2, \dots . This sequence is related to cycle lengths in the cycle decomposition of permutations. The upshot is that the counting of gauge invariant operators at large rank can be given in terms of a sum over the infinite sequence of integers p_i . The general formula takes the

form of an infinite product over i , where i is related to the cycle lengths in the above description

$$\prod_{i=1}^{\infty} F_0^{[n]}(\{x_{ab} \rightarrow \sum_{\alpha} x_{ab;\alpha}^i\}) \quad (2.0.2)$$

Each factor in the product is built from a basic function $F_0^{[n]}(\{x_{ab}\})$. The integer n is the number of gauge nodes and the subscript denotes the unflavoured case. The index α runs over the different edges with the same starting gauge node a and the same ending gauge node b . If there is no edge from a to b , we substitute $x_{ab} \rightarrow 0$. This structure was derived in [26] for the case without flavour. The function $F_0^{[n]}(\{x_{ab}\})$ was explicitly computed for the case of quivers with small numbers of nodes and a simple general formula was guessed. A general formula for $F_0^{[n]}(\{x_{ab}\})$ was also derived in terms of contour integrals. However, the proof that the contour integrals really give the guessed simple form for the $F_0^{[n]}(\{x_{ab}\})$ was not given. This missing step is completed in this chapter. We also find that this function can be written in terms of a determinant:

$$F_0^{[n]}(\{x_{ab}\}) = \frac{1}{\det(1_n - X_n)} \quad (2.0.3)$$

The matrix X_n is defined to have variables x_{ab} as the entry in the a -th row and b -th column. We may think of X_n as a *weighted adjacency matrix* associated with the quiver graph which has n nodes and a single directed edge for every specified starting point a and end-point b . We refer to this latter quiver graph as the *complete n -node quiver graph*. The notion of adjacency matrix, and weighted versions thereof, are commonly used in the context of graph theory [70, 71]. The (a, b) entry of the adjacency matrix of a directed graph is equal to the number of oriented edges M_{ab} from node a to node b . In the present studies, it is natural to associate $\sum_{\alpha} x_{ab,\alpha}$ as the weight for a given pair of nodes, which reduces to M_{ab} , the entry of the adjacency matrix, when the $x_{ab,\alpha}$ are set to 1.

While the infinite product (2.0.2) counts gauge invariant operators, the building block $F_0^{[n]}(\{x_{ab}\})$ itself (2.0.3) has no obvious counting interpretation in terms of the original gauge theory problem. Nevertheless, after applying a well-known identity, the determinant formula (2.0.3) makes it clear that the expansion coefficients of this building block are positive, which suggests a counting interpretation. We give such an interpretation. It is in terms of a word counting problem involving letters corresponding to simple closed loops on the complete quiver graph. Two letters commute if the loops do not share a node but they do not commute if the loops do share a node. This, we describe as the *closed string word counting* problem. There is an equivalent word counting problem in terms of *charge conserving open string words*. Here open string words are made of string bits - which are edges of the quiver. Two different string bits do not commute if they have the same starting point. They commute if they do not share a starting point. Charge conserving open string words have the same number of open string bits leaving any vertex as arriving at that vertex. This charge-conserving open string word counting is actually directly related to the formulae in our derivations leading to the result. Its equiv-

alence to the closed string word counting is a highly non-trivial fact, which is the content of a theorem of Cartier-Foata [64] from the sixties! This type of word-counting is of interest in pure mathematics and theoretical computer science, where it is known under the heading of Cartier-Foata monoids [64, 65, 72]. The monoid structure arises because the words can be composed to form other words, thus giving a product which turns the set of words into a monoid.

The infinite product form and the explicit formula for the building block, for the case of flavoured quivers, is derived using contour integrals in [1]. The computation is presented in this chapter. We find that the building block for the case of flavoured quivers is closely related to the unflavoured case. It is worth emphasizing that the contour integrals we deal with for the large N limit are significantly simpler than the original integrals over the $U(N)$ groups. The contour integrals we use involve n complex variables z_a , where n is the number of nodes in the quiver.

We stress that, even though the motivation of this work is to study 4 dimensional $\mathcal{N} = 1$ gauge theories, focusing on the holomorphic gauge invariant operators made from chiral superfields which have a complex scalar as the lowest component of the superspace expansion, the counting techniques we developed do not depend on either the spacetime dimension or on the amount of supersymmetry. The results apply equally to holomorphic gauge invariants of a matrix quantum mechanics, or of a matrix model of multiple complex matrices transforming as bifundamentals.

The chapter is organized as follows. Section 2 gives a summary of the main results. Section 3 starts from an integral over a product of unitary groups $\prod_a U(N_a)$, which gives the generating function for the counting of gauge-invariant operators [66, 67]. This generating function depends on chemical potentials, one for each of the bifundamental fields in the theory, i.e. one for each edge in the quiver joining gauge nodes. In addition, there are chemical potentials for the global charges under the Cartan of the global symmetry groups. The integrand is expanded in terms of characters of the (gauge and global) unitary groups along with characters of permutation groups. The gauge unitary group characters can be integrated using orthogonality of the irreducible characters. The resulting expressions contain sums involving Young diagrams and group theoretic multiplicities called Littlewood-Richardson coefficients [68]. These sums are done in Appendix B.1.1 and the outcome is an infinite product parametrised by an integer i . For each i there are sums over integers, one for each edge of the quiver. We call these edge variables $p_{ab,\alpha}$, $p_{a,\beta}$, $\bar{p}_{a,\gamma}$. These sums are constrained by Kronecker delta functions, one for each gauge node of the quiver. The structures of the sums in each factor of the i -product are closely related. Once these sums are performed for $i = 1$, the expressions for the factor at each i can be written down. The $i = 1$ factor is the building block function $F^{[n]}(\{x_{ab}\}, \{t_a\}, \{\bar{t}_a\})$ which can be viewed as the generalization of $F_0^{[n]}(\{x_{ab}\})$ for unflavoured quivers to flavoured quivers. The Kronecker delta constraints on the edge variables are expressed by introducing complex variables z_a , giving a product of n contour integrals.

Section 4 evaluates the contour integrals for the case without fundamental matter, recovering the result written down in [26]. This involves finding the right prescription for picking up poles.

The prescription is simple and intuitively very plausible. It is derived from the inequalities which ensure the applicability of the summation formulae leading to the contour integral formula obtained in Section 3. The derivation is presented in Appendix B.2. With the specified pole prescription in hand, we describe the calculation of the integral. The integrand involves n factors and there are n integration variables z_1, z_2, \dots, z_n . The recursive evaluation of the integral leads to a formula (2.3.12) for the poles encountered at each stage. The pole coefficients in this formula can be expressed neatly in terms of paths in the complete quiver graph. This expression is equation (2.3.25) and is proved in Appendix B.4. Using this expression we are able to prove the formula for $F_0^{[n]}$, an inverse of a signed sum over permutations of subsets of n nodes, guessed in [26]. We then recognise that the denominator is a determinant $\det(\mathbb{K}_n - X_n)$, which leads to (2.0.3). Section 2.4 gives the combinatoric meaning of the basic building block in terms of word counting problems. Appendix B.5 illustrates this interpretation in the case of 2-node and 3-node quivers. Section 5 evaluates the n countour integrals for the building block function $F^{[n]}(\{x_{ab}\}, \{t_a\}, \{\bar{t}_a\})$ and expresses it in terms of determinants and minors of the matrix $(1_n - X_n)$. This gives a neat formula (2.5.16) for $F^{[n]}(\{x_{ab}\}, \{t_a\}, \{\bar{t}_a\})$ in terms of $F_0^{[n]}(\{x_{ab}\})$. Appendix B.6 derives this formula, following a similar strategy to the unflavoured case, namely finding expressions for pole coefficients in terms of paths in a complete n -node quiver. Section 6 gives applications of the general counting formulae by considering explicit quiver gauge theories with fundamental matter.

2.1 From gauge invariants to determinants and word counting

For quiver gauge theories with bi-fundamental fields, the generating function $\mathcal{Z}(\{x_{ab}\})$ for local holomorphic gauge invariant operators constructed from the chiral fields, is given by [26]

$$\mathcal{Z}(\{x_{ab,\alpha}\}) = \prod_{i=1} F_0^{[n]}(\{x_{ab} \rightarrow \sum_{\alpha} x_{ab;\alpha}^i\}) \quad (2.1.1)$$

It is useful to introduce the *complete n -node quiver* which is a quiver that has 1 edge for every specified start and end-point. An expression for $F_0^{[n]}(\{x_{ab}\})$ was given as the inverse of a sum over permutations of subsets of the set of nodes of the n -node complete quiver. Equivalently this is an expression in terms of loops in the complete quiver

$$F_0^{[n]}(\{y_i\}) = \left(1 + \sum_{\mathbb{V} \subseteq V_n} \sum_{\sigma \in \text{Sym}(\mathbb{V})} \prod_{i \in \text{Cycles}(\sigma)} (-y_i) \right)^{-1} \quad (2.1.2)$$

Here \mathbb{V} is any subset of nodes of the quiver (except the empty set), and for the cycle $(abc \cdots d)$ we define $y_{(abc \cdots d)} \equiv x_{ab} x_{bc} \cdots x_{da}$. In this we observe, using standard matrix identities, that

$$F_0^{[n]} = \frac{1}{\det(1_n - X_n)} \quad (2.1.3)$$

where X_n is an $n \times n$ matrix with entries x_{ab} . This formula is the subject of the Mac Mahon master theorem [73].

While the function $\mathcal{Z}(\{x_{ab,\alpha}\})$ counts gauge invariant operators, the gauge theory set-up does not immediately offer a combinatoric interpretation for $F_0^{[n]}(\{x_{ab}\})$. We give an interpretation of $F_0^{[n]}$ in terms of word-counting problems associated with the complete n -node quiver. There are in fact two counting problems, one of them is a closed string counting problem. Consider a language where the words are made from letters which correspond to simple loops in the n -node quiver. These are loops that visit each node of the quiver no more than once. These letters equivalently correspond to cyclic permutations of any subset of integers $\{1, \dots, n\}$. The words are constructed as strings, i.e. ordered sequences, of these letters with the additional equivalences introduced that letters corresponding to two simple loops c and c' commute if the loops do not share a node. We denote these letters by \hat{y}_c . Then

$$\hat{y}_c \hat{y}_{c'} = \hat{y}_{c'} \hat{y}_c \tag{2.1.4}$$

if c and c' are loops that do not share a node. Any word contains a list of these letters $\hat{y}_{c_1}, \hat{y}_{c_2} \dots \hat{y}_{c_k}$ with multiplicities (m_1, m_2, \dots, m_k) . With these specified numbers, there is a multiplicity $\mathcal{M}(m_1, \dots, m_k)$ of words since, in general, the order of the letters matters: if two loops $\hat{y}_c, \hat{y}_{c'}$ do share a node then $\hat{y}_c \hat{y}_{c'} \neq \hat{y}_{c'} \hat{y}_c$. The expansion of $F_0^{[n]}$ in terms of the loop variables contains terms of the form $y_{c_1}^{m_1} y_{c_2}^{m_2} \dots y_{c_k}^{m_k}$ with coefficients, which are precisely the multiplicities of the words $\mathcal{M}(m_1, \dots, m_k)$.

This is a remarkable new connection between a counting problem of words built from a partially commuting set of letters and the counting of gauge invariants. Since the letters correspond to simple loops, we call this the closed string word counting problem. Thus $F_0^{[n]}(\{x_{ab}\})$ generates multiplicities of closed string words. In section 2.4 we explain why this is true. Along the way, we introduce another word counting formula based on letters corresponding to open string bits.

2.1.1 Generalization to flavoured quivers

We extend the counting results to quivers that have bifundamental matter fields, as well as fundamental matter. We find again that the counting in the limit of large rank gauge groups is given as an infinite product. Each factor is obtained by making a simple substitution in a basic function $F^{[n]}(\{x_{ab}, t_a, \bar{t}_a\})$, for the case quivers with n gauge nodes. The function $F^{[n]}$ has an elegant expression in terms of matrices X_n and Λ_n , whose matrix elements are

$$X_n|_{ab} = x_{ab}, \quad \Lambda_n|_{ab} = t_a \bar{t}_b \tag{2.1.5}$$

Let us also define another $n \times n$ matrix,

$$\chi_n \equiv (1_n - X_n)^{-1} \tag{2.1.6}$$

In terms of these, $F^{[n]}$ is the determinant

$$F^{[n]}(\{x_{ab}\}, \{t_a\}, \{\bar{t}_a\}) = \det(\chi_n \exp[\chi_n \Lambda_n]) = \det(\chi_n) \exp(\text{tr}(\chi_n \Lambda_n)) \quad (2.1.7)$$

The generating function \mathcal{Z} can be obtained through the infinite product

$$\begin{aligned} & \mathcal{Z}(\{x_{ab,\alpha}\}, \{\mathcal{T}_{a,\beta}\}, \{\bar{\mathcal{T}}_{a,\gamma}\}) \\ &= \prod_i F^{[n]} \left(\left\{ x_{ab} \rightarrow \sum_{\alpha} x_{ab,\alpha}^i \right\}, \left\{ t_a \rightarrow \sum_{\beta} \frac{\text{Tr}(\mathcal{T}_{a,\beta}^i)}{\sqrt{i}} \right\}, \left\{ \bar{t}_a \rightarrow \sum_{\gamma} \frac{\text{Tr}(\bar{\mathcal{T}}_{a,\gamma}^i)}{\sqrt{i}} \right\} \right) \end{aligned} \quad (2.1.8)$$

In the course of our derivation of $F^{[n]}$, we find the identity

$$\begin{aligned} F^{[n]} &= \det(\chi_n \exp[\chi_n \Lambda_n]) \\ &= \sum_{\vec{p}} \prod_{a=1}^n \left(p_a + \sum_{b=1}^n p_{ab} \right)! \left(\prod_{b=1}^n \frac{x_{ab}^{p_{ab}}}{p_{ab}!} \right) \left(\frac{y_a^{p_a}}{p_a!} \right) \left(\frac{\bar{y}_a^{\bar{p}_a}}{\bar{p}_a!} \right) \delta \left(p_a - \bar{p}_a + \sum_{b=1}^n (p_{ab} - p_{ba}) \right) \end{aligned} \quad (2.1.9)$$

with $\vec{p} = \bigcup_{a=1}^n \{\bigcup_{b=1}^n p_{ab}, p_a, \bar{p}_a\}$. For the unflavoured case, this implies

$$F_0^{[n]} = \frac{1}{\det(1_n - X_n)} = \sum_{\vec{p}} \prod_{a=1}^n \left(\sum_{b=1}^n p_{ab} \right)! \left(\prod_{b=1}^n \frac{x_{ab}^{p_{ab}}}{p_{ab}!} \right) \delta \left(\sum_{b=1}^n (p_{ab} - p_{ba}) \right) \quad (2.1.10)$$

where now $\vec{p} = \bigcup_{a,b=1}^n \{p_{ab}\}$. This formula is interpreted in section 2.4 in terms of the counting of words built from partially commuting open string bits. The open string word counting has previously been studied in [64] and its equivalence to the closed string word counting given.

2.2 Group integral formula to partition sums

In this section we will derive a contour integral formulation for the generating function \mathcal{Z} . Our starting point is the group integral representation [66, 67]

$$\begin{aligned} \mathcal{Z}(\{x_{ab,\alpha}\}, \{t_{a,\beta,k}\}, \{\bar{t}_{a,\gamma,k}\}) &= \int \left(\prod_a dU_a \right) \\ &\times \prod_a \exp \left\{ \sum_{i=1}^{\infty} \frac{1}{i} \left[\sum_{b,\alpha} x_{ab,\alpha}^i \text{Tr}(U_a^{\dagger i}) \text{Tr}(U_b^i) \right. \right. \\ &\quad \left. \left. + \sum_{\beta} \sum_{k=1}^{F_{a,\beta}} t_{a,\beta,k}^i \text{Tr}(U_a^{\dagger i}) + \sum_{\gamma} \sum_{k=1}^{\bar{F}_{a,\gamma}} \bar{t}_{a,\gamma,k}^i \text{Tr}(U_a^i) \right] \right\} \end{aligned} \quad (2.2.1)$$

Here $x_{ab,\alpha}$ is the chemical potential for the $\Phi_{ab,\alpha}$ field, while $t_{a,\beta,k} = e^{i\theta_{a,\beta,k}}$ is the chemical potential for a quark $Q_{a,\beta,k}$ charged under the $U(1)_k$ of the maximal torus $\prod_{j=1}^{F_{a,\beta}} U(1)_j \subset U(F_{a,\beta})$. Analogously, $\bar{t}_{a,\gamma,k} = e^{-i\theta_{a,\gamma,k}}$ is the chemical potential for an antiquark $\bar{Q}_{a,\gamma,k}$ charged under the $U(1)_k$ of $\prod_{j=1}^{\bar{F}_{a,\gamma}} U(1)_j \subset U(\bar{F}_{a,\gamma})$. Expanding the generating function gives the *counting function* $\mathcal{N}(\{n_{ab,\alpha}\}, \{n_{a,\beta,k}\}, \{\bar{n}_{a,\gamma,k}\})$ for specified numbers $n_{ab,\alpha}$ of bifundamentals $\Phi_{ab,\alpha}$, $n_{a,\beta,k}$ of quarks $Q_{a,\beta,k}$ and $\bar{n}_{a,\gamma,k}$ anti-quarks $\bar{Q}_{a,\gamma,k}$:

$$\begin{aligned} \mathcal{Z}(\{x_{ab,\alpha}\}, \{t_{a,\beta,k}\}, \{\bar{t}_{a,\gamma,k}\}) &= \sum_{\{n_{ab,\alpha}\}} \sum_{\{n_{a,\beta,k}\}} \sum_{\{\bar{n}_{a,\gamma,k}\}} \mathcal{N}(\{n_{ab,\alpha}\}, \{n_{a,\beta,k}\}, \{\bar{n}_{a,\gamma,k}\}) \\ &\quad \times \left(\prod_{a,b,\alpha} x_{ab,\alpha}^{n_{ab,\alpha}} \right) \left(\prod_{a,\beta,k} t_{a,\beta,k}^{n_{a,\beta,k}} \right) \left(\prod_{a,\gamma,k} \bar{t}_{a,\gamma,k}^{\bar{n}_{a,\gamma,k}} \right) \end{aligned} \quad (2.2.2)$$

The chemical potentials for the quark/antiquark matter content can be nicely encoded in the unitary matrices $\mathcal{T}_{a,\beta} = \text{diag}(t_{a,\beta,1}, t_{a,\beta,2}, \dots, t_{a,\beta,F_{a,\beta}})$ and $\bar{\mathcal{T}}_{a,\gamma} = \text{diag}(\bar{t}_{a,\gamma,1}, \bar{t}_{a,\gamma,2}, \dots, \bar{t}_{a,\gamma,\bar{F}_{a,\gamma}})$ respectively, so that

$$\begin{aligned} \mathcal{Z}(\{x_{ab,\alpha}\}, \{\mathcal{T}_{a,\beta}\}, \{\bar{\mathcal{T}}_{a,\gamma}\}) &= \int \left(\prod_a dU_a \right) \prod_a \exp \left\{ \sum_{i=1}^{\infty} \frac{1}{i} \left[\sum_{b,\alpha} x_{ab,\alpha}^i \text{Tr}(U_a^{\dagger i}) \text{Tr}(U_b^i) \right. \right. \\ &\quad \left. \left. + \sum_{\beta} \text{Tr}(U_a^{\dagger i}) \text{Tr}(\mathcal{T}_{a,\beta}^i) + \sum_{\gamma} \text{Tr}(\bar{\mathcal{T}}_{a,\gamma}^i) \text{Tr}(U_a^i) \right] \right\} \end{aligned} \quad (2.2.3)$$

Using the shorthand notation $\int (\prod_a dU_a) \equiv \int$ and expanding the exponential function we get

$$\begin{aligned} &\mathcal{Z}(\{x_{ab,\alpha}\}, \{\mathcal{T}_{a,\beta}\}, \{\bar{\mathcal{T}}_{a,\gamma}\}) \\ &= \int \prod_a \left\{ \left(\sum_{\{p_{ab,\alpha}^{(i)}\}_a} \prod_{b,\alpha} \frac{x_{ab,\alpha}^{\sum_i i p_{ab,\alpha}^{(i)}}}{\prod_i p_{ab,\alpha}^{(i)}! n^{p_{ab,\alpha}^{(i)}}} \prod_i (\text{Tr } U_a^{\dagger i})^{p_{ab,\alpha}^{(i)}} (\text{Tr } U_b^i)^{p_{ab,\alpha}^{(i)}} \right) \right. \\ &\quad \times \left(\sum_{\{p_{a,\beta}^{(i)}\}_a} \prod_{\beta} \frac{1}{\prod_i p_{a,\beta}^{(i)}! n^{p_{a,\beta}^{(i)}}} \prod_i (\text{Tr } U_a^{\dagger i})^{p_{a,\beta}^{(i)}} (\text{Tr } \mathcal{T}_{a,\beta}^i)^{p_{a,\beta}^{(i)}} \right) \\ &\quad \left. \times \left(\sum_{\{\bar{p}_{a,\gamma}^{(i)}\}_a} \prod_{\gamma} \frac{1}{\prod_i \bar{p}_{a,\gamma}^{(i)}! n^{\bar{p}_{a,\gamma}^{(i)}}} \prod_i (\text{Tr } \bar{\mathcal{T}}_{a,\gamma}^i)^{\bar{p}_{a,\gamma}^{(i)}} (\text{Tr } U_a^i)^{\bar{p}_{a,\gamma}^{(i)}} \right) \right\} \end{aligned} \quad (2.2.4)$$

where $\sum_{\{p_{ab,\alpha}^{(i)}\}_a} \equiv \prod_{i,b,\alpha} \sum_{p_{ab,\alpha}^{(i)}=0}^{\infty}$, $\sum_{\{p_{a,\beta}^{(i)}\}_a} \equiv \prod_{\beta,i} \sum_{p_{a,\beta,i}}$ and $\sum_{\{\bar{p}_{a,\gamma}^{(i)}\}_a} \equiv \prod_{\gamma,i} \sum_{p_{\gamma,i}}$. Rear-

ranging sums and collecting like terms, we obtain

$$\begin{aligned}
 & \mathcal{Z}(\{x_{ab,\alpha}\}, \{\mathcal{T}_{a,\beta}\}, \{\bar{\mathcal{T}}_{a,\gamma}\}) \\
 &= \sum_{\{p_{ab,\alpha}^{(i)}\}} \sum_{\{p_{a,\beta}^{(i)}\}} \sum_{\{\bar{p}_{a,\gamma}^{(i)}\}} \int \left(\prod_{a,b,\alpha} \frac{x_{ab,\alpha}^{\sum_i i p_{ab,\alpha}^{(i)}}}{\prod_i p_{ab,\alpha}^{(i)}! n^{p_{ab,\alpha}^{(i)}}} \right) \left(\prod_{a,\beta} \frac{1}{\prod_i p_{a,\beta}^{(i)}! i^{p_{a,\beta}^{(i)}}} \right) \left(\prod_{a,\gamma} \frac{1}{\prod_i \bar{p}_{a,\gamma}^{(i)}! i^{\bar{p}_{a,\gamma}^{(i)}}} \right) \\
 & \quad \times \left\{ \prod_{a,i} (\mathrm{Tr} U_a^{\dagger i})^{\sum_{b,\alpha} p_{ab,\alpha}^{(i)} + \sum_{\beta} p_{a,\beta}^{(i)}} (\mathrm{Tr} U_a^i)^{\sum_{b,\alpha} p_{ba,\alpha}^{(i)} + \sum_{\gamma} \bar{p}_{a,\gamma}^{(i)}} \right\} \\
 & \quad \times \prod_{a,i} \left[\prod_{\beta} (\mathrm{Tr} \mathcal{T}_{a,\beta}^i)^{p_{a,\beta}^{(i)}} \right] \left[\prod_{\gamma} (\mathrm{Tr} \bar{\mathcal{T}}_{a,\gamma}^i)^{\bar{p}_{a,\gamma}^{(i)}} \right]
 \end{aligned} \tag{2.2.5}$$

We now collect powers of $x_{ab,\alpha}$, $\mathcal{T}_{a,\beta}$, $\bar{\mathcal{T}}_{a,\gamma}$ denoted $n_{ab,\alpha}$, $n_{a,\beta}$, $\bar{n}_{a,\gamma}$, and introduce the quantities

$$\vec{p}_{ab,\alpha} = \cup_i \{p_{ab,\alpha}^{(i)}\}, \quad \vec{p}_{a,\beta} = \cup_i \{p_{a,\beta}^{(i)}\}, \quad \vec{\bar{p}}_{a,\gamma} = \cup_i \{\bar{p}_{a,\gamma}^{(i)}\} \tag{2.2.6}$$

These form partitions of $n_{ab,\alpha}$, $n_{a,\beta}$, $\bar{n}_{a,\gamma}$, which can be interpreted as cycle lengths of permutations $\sigma_{ab,\alpha} \in S_{n_{ab,\alpha}}$, $\sigma_{a,\beta} \in S_{n_{a,\beta}}$ and $\bar{\sigma}_{a,\gamma} \in S_{\bar{n}_{a,\gamma}}$ respectively. These cycle structures determine conjugacy classes denoted $[\sigma_{ab,\alpha}]$, $[\sigma_{a,\beta}]$, $[\bar{\sigma}_{a,\gamma}]$. We have

$$\sum_{i=1}^{\infty} i p_{ab,\alpha}^{(i)} = n_{ab,\alpha}, \quad |\vec{p}_{ab,\alpha}| = \frac{n_{ab,\alpha}!}{\prod_i p_{ab,\alpha}^{(i)}! i^{p_{ab,\alpha}^{(i)}}} \tag{2.2.7}$$

and similarly for $\vec{p}_{a,\beta}$ and $\vec{\bar{p}}_{a,\gamma}$. The second equation above gives the number of permutations with the specified cycle structure. We also use the identity

$$\prod_i (\mathrm{Tr} U^i)^{[\sigma]^{(i)}} = \sum_{\substack{R \vdash n \\ l(R) \leq N}} \chi_R(\sigma) \chi_R(U), \quad \sigma \in S_n, \quad U \in U(N) \tag{2.2.8}$$

which follows from Schur-Weyl duality (see e.g. [68]): here R is a partition of n and $[\sigma]^{(i)}$ is the number of cycles of length i in σ , which is a function of the conjugacy class $[\sigma]$. The Young diagrams are constrained to have no more than N rows, which is expressed as $l(R) \leq N$. This encodes the constraints following from finiteness of the ranks N_a . For $n_a \leq N_a$, these constraints can be dropped, which is the origin of simplifications at large N_a . Collecting powers of traces

of U_a^\dagger , this equation can be used to rewrite the traces in (2.2.5) as

$$\prod_i (\text{Tr } U_a^{\dagger i})^{\sum_{b,\alpha} p_{ab,\alpha}^{(i)} + \sum_{\beta} p_{a,\beta}^{(i)}} = \sum_{\substack{R_a \vdash n_a \\ l(R_a) \leq N_a}} \chi_{R_a}(\times_{b,\alpha} \sigma_{ab,\alpha} \times_{\beta} \sigma_{a,\beta}) \chi_{R_a}(U_a^\dagger),$$

$$n_a = \sum_{b,\alpha} n_{ab,\alpha} + \sum_{\beta} n_{a,\beta} \quad (2.2.9)$$

and similarly for the other terms. The product of the permutations over b, α, β describes an outer product of permutations acting on subsets of size $n_{ab,\alpha}, n_{a,\beta}$ of n_a . Using these definitions, we can write

$$\mathcal{Z}(\{x_{ab,\alpha}\}, \{\mathcal{T}_{a,\beta}\}, \{\bar{\mathcal{T}}_{a,\gamma}\}) = \sum_{\{n_{ab,\alpha}\}} \sum_{\substack{\{n_{a,\beta}\} \\ \{\bar{n}_{a,\gamma}\}}} \sum_{\{\vec{p}_{ab,\alpha}\}} \sum_{\{\vec{p}_{a,\beta}\}} \sum_{\{\vec{p}_{a,\gamma}\}} \quad (2.2.10)$$

$$\times \int \left(\prod_{a,b,\alpha} \frac{x_{ab,\alpha}^{n_{ab,\alpha}}}{n_{ab,\alpha}!} |\vec{p}_{ab,\alpha}| \right) \left(\prod_{a,\beta} \frac{1}{n_{a,\beta}!} |\vec{p}_{a,\beta}| \right) \left(\prod_{a,\gamma} \frac{1}{\bar{n}_{a,\gamma}!} |\vec{p}_{a,\gamma}| \right)$$

$$\times \prod_a \left\{ \sum_{\substack{R_a \vdash n_a \\ l(R_a) \leq N_a}} \sum_{\substack{S_a \vdash n_a \\ l(S_a) \leq N_a}} \chi_{R_a}(\times_{b,\alpha} \sigma_{ab,\alpha} \times_{\beta} \sigma_{a,\beta}) \chi_{S_a}(\times_{b,\alpha} \sigma_{ba,\alpha} \times_{\gamma} \bar{\sigma}_{a,\gamma}) \chi_{R_a}(U_a^\dagger) \chi_{S_a}(U_a) \right\}$$

$$\times \prod_a \left\{ \sum_{\substack{\{r_{a,\beta} \vdash n_{a,\beta}\} \\ \{l(r_{a,\beta}) \leq F_{a,\beta}\}_a}} \prod_{\beta} \chi_{r_{a,\beta}}(\sigma_{a,\beta}) \chi_{r_{a,\beta}}(\mathcal{T}_{a,\beta}) \right\} \left\{ \sum_{\substack{\{\bar{r}_{a,\gamma} \vdash \bar{n}_{a,\gamma}\} \\ \{l(\bar{r}_{a,\gamma}) \leq \bar{F}_{a,\gamma}\}_a}} \prod_{\gamma} \chi_{\bar{r}_{a,\gamma}}(\bar{\sigma}_{a,\gamma}) \chi_{\bar{r}_{a,\gamma}}(\bar{\mathcal{T}}_{a,\gamma}) \right\}$$

where $\sigma_{ab,\alpha}, \sigma_{a,\beta}$ and $\bar{\sigma}_{a,\gamma}$ are representatives of the conjugacy classes specified by $\vec{p}_{ab,\alpha}, \vec{p}_{a,\beta}$ and $\vec{p}_{a,\gamma}$ respectively. We can now cast the sums over these vectors into sums over the permutations $\sigma_{ab,\alpha} \in S_{n_{ab,\alpha}}, \sigma_{a,\beta} \in S_{n_{a,\beta}}$ and $\bar{\sigma}_{a,\gamma} \in S_{\bar{n}_{a,\gamma}}$. We also use the symmetric group character expansion

$$\chi_{R_a}(\times_{b,\alpha} \sigma_{ab,\alpha} \times_{\beta} \sigma_{a,\beta})$$

$$= \sum_{\substack{\cup_{b,\alpha} \{r_{ab,\alpha} \vdash n_{ab,\alpha}\} \\ \cup_{\beta} \{r_{a,\beta} \vdash n_{a,\beta}\}}} g(\cup_{b,\alpha} r_{ab,\alpha} \cup_{\beta} r_{a,\beta}; R_a) \left(\prod_{b,\alpha} \chi_{r_{ab,\alpha}}(\sigma_{ab,\alpha}) \right) \left(\prod_{\beta} \chi_{r_{a,\beta}}(\sigma_{a,\beta}) \right) \quad (2.2.11)$$

and similarly for $\chi_{S_a}(\times_{b,\alpha} \sigma_{ba,\alpha} \times_{\gamma} \bar{\sigma}_{a,\gamma})$. In the formula above, $g(\cup_{b,\alpha} r_{ab,\alpha} \cup_{\beta} r_{a,\beta}; R_a)$ is a Littlewood-Richardson coefficient. This is the multiplicity of the representation $\otimes_{b,\alpha} r_{ab,\alpha} \otimes_{\beta} r_{a,\beta}$ of the subgroup $\times_{b,\alpha} S_{n_{ab,\alpha}} \times_{\beta} S_{n_{a,\beta}}$ when the representation R_a of S_{n_a} is decomposed into irreducibles of the product subgroup. Finally, using the $U(N)$ character orthogonality

formula

$$\int dU \chi_R(U^\dagger) \chi_S(U) = \delta_{R,S} \quad (2.2.12)$$

we obtain

$$\begin{aligned} & \mathcal{Z}(\{x_{ab,\alpha}\}, \{\mathcal{T}_{a,\beta}\}, \{\bar{\mathcal{T}}_{a,\gamma}\}) \\ &= \sum_{\{n_{ab,\alpha}\}} \sum_{\substack{\{n_{a,\beta}\} \\ \{\bar{n}_{a,\gamma}\}}} \sum_{\{\sigma_{ab,\alpha}\}} \sum_{\{\sigma_{a,\beta}\}} \sum_{\{\bar{\sigma}_{a,\gamma}\}} \left(\prod_{a,b,\alpha} \frac{x_{ab,\alpha}^{n_{ab,\alpha}}}{n_{ab,\alpha}!} \right) \left(\prod_{a,\beta} \frac{1}{n_{a,\beta}!} \right) \left(\prod_{a,\gamma} \frac{1}{\bar{n}_{a,\gamma}!} \right) \\ & \times \sum_{\substack{\{R_a \vdash n_a\} \\ \{l(R_a) \leq N_a\}}} \sum_{\substack{\{r_{ab,\alpha} \vdash n_{ab,\alpha}\} \\ \{s_{ab,\alpha} \vdash n_{ab,\alpha}\}}} \sum_{\substack{\{s_{a,\beta} \vdash n_{a,\beta}\} \\ \{\bar{s}_{a,\gamma} \vdash \bar{n}_{a,\gamma}\}}} \left\{ \prod_a g(\cup_{b,\alpha} r_{ab,\alpha} \cup_\beta s_{a,\beta}; R_a) g(\cup_{b,\alpha} s_{ba,\alpha} \cup_\gamma \bar{s}_{a,\gamma}; R_a) \right\} \\ & \times \left(\prod_{a,b,\alpha} \chi_{r_{ab,\alpha}}(\sigma_{ab,\alpha}) \chi_{s_{ba,\alpha}}(\sigma_{ba,\alpha}) \right) \left(\prod_{a,\beta} \chi_{s_{a,\beta}}(\sigma_{a,\beta}) \right) \left(\prod_{a,\gamma} \chi_{\bar{s}_{a,\gamma}}(\bar{\sigma}_{a,\gamma}) \right) \\ & \times \sum_{\substack{\{r_{a,\beta} \vdash n_{a,\beta}\} \\ \{\bar{r}_{a,\gamma} \vdash \bar{n}_{a,\gamma}\}}} \left\{ \prod_{a,\beta} \chi_{r_{a,\beta}}(\sigma_{a,\beta}) \chi_{r_{a,\beta}}(\mathcal{T}_{a,\beta}) \right\} \left\{ \prod_{a,\gamma} \chi_{\bar{r}_{a,\gamma}}(\bar{\sigma}_{a,\gamma}) \chi_{\bar{r}_{a,\gamma}}(\bar{\mathcal{T}}_{a,\gamma}) \right\} \end{aligned} \quad (2.2.13)$$

Note that we dropped the $l(r_{a,\beta}) \leq F_{a,\beta}$ constraint on the sum over quark representations, since contributions coming from representations with $l(r_{a,\beta}) > F_{a,\beta}$ are automatically zero due to the vanishing of $\chi_{r_{a,\beta}}(\mathcal{T}_{a,\beta})$ (similar comments hold for the sum over antiquark representations as well).

Finally, using the orthogonality of the symmetric group characters $\sum_{\sigma \in S_n} \chi_r(\sigma) \chi_s(\sigma) = n! \delta_{r,s}$, we get the formula

$$\mathcal{Z}(\{x_{ab,\alpha}\}, \{\mathcal{T}_{a,\beta}\}, \{\bar{\mathcal{T}}_{a,\gamma}\}) = \sum_{\{n_{ab,\alpha}\}} \sum_{\substack{\{n_{a,\beta}\} \\ \{\bar{n}_{a,\gamma}\}}} \left(\prod_{a,b,\alpha} x_{ab,\alpha}^{n_{ab,\alpha}} \right) \sum_{\substack{\{R_a \vdash n_a\} \\ \{l(R_a) \leq N_a\}}} \sum_{\substack{\{r_{ab,\alpha} \vdash n_{ab,\alpha}\} \\ \{s_{a,\beta} \vdash n_{a,\beta}\} \\ \{\bar{s}_{a,\gamma} \vdash \bar{n}_{a,\gamma}\}}} \sum_{\substack{\{r_{a,\beta} \vdash n_{a,\beta}\} \\ \{\bar{r}_{a,\gamma} \vdash \bar{n}_{a,\gamma}\}}} \quad (2.2.14)$$

$$\prod_a g(\cup_{b,\alpha} r_{ab,\alpha} \cup_\beta r_{a,\beta}; R_a) g(\cup_{b,\alpha} r_{ba,\alpha} \cup_\gamma \bar{r}_{a,\gamma}; R_a) \left(\prod_\beta \chi_{r_{a,\beta}}(\mathcal{T}_{a,\beta}) \right) \left(\prod_\gamma \chi_{\bar{r}_{a,\gamma}}(\bar{\mathcal{T}}_{a,\gamma}) \right)$$

Note that setting $\mathcal{T}_{a,\beta} = t_{a,\beta} 1_{a,\beta}$ ($\bar{\mathcal{T}}_{a,\gamma} = \bar{t}_{a,\gamma} 1_{a,\gamma}$) gives an unrefined generating function, in which we no longer distinguish quark (antiquark) states charged under different $U(1)$ factors in the maximal torus of $U(F_{a,\beta})$ ($U(\bar{F}_{a,\gamma})$). This unrefinement is immediately obtained from

(2.2.14) through the substitutions

$$\chi_{r_{a,\beta}}(\mathcal{T}_{a,\beta}) \rightarrow \dim^{U(F_{a,\beta})}(r_{a,\beta}) t_{a,\beta}^{n_{a,\beta}}, \quad \chi_{\bar{r}_{a,\gamma}}(\bar{\mathcal{T}}_{a,\gamma}) \rightarrow \dim^{U(\bar{F}_{a,\gamma})}(\bar{r}_{a,\gamma}) \bar{t}_{a,\gamma}^{\bar{n}_{a,\gamma}} \quad (2.2.15)$$

The $\dim^{U(F)}(r)$ is the dimension of the representation r of $U(F)$.

For an F dimensional unitary matrix \mathcal{T} with eigenvalues (t_1, t_2, \dots, t_F) and a partition R of n , we have

$$\chi_R(\mathcal{T}) = \sum_{\sigma \in S_n} \frac{\chi_R(\sigma)}{n!} \prod_i (\text{Tr } \mathcal{T}^i)^{[\sigma]^{(i)}} = \sum_{\{n_j\}} g(\cup_j [n_j]; R) \prod_{j=1}^F t_j^{n_j} \quad (2.2.16)$$

where $n = \sum_j n_j$ and $[n_j]$ is the single-row totally symmetric representation of S_{n_j} . These Littlewood-Richardson multiplicities for single-row representations and a general R are called Kostka numbers [68]. Note also that the Littlewood-Richardson multiplicities satisfy [68, 74]

$$\sum_s g(r_1, s; R) g(r_2, r_3; s) = g(r_1, r_2, r_3; R) \quad (2.2.17)$$

Using these identities, we can write the counting function $\mathcal{N}(\{n_{ab,\alpha}\}, \{n_{a,\beta,k}\}, \{\bar{n}_{a,\gamma,k}\})$ as

$$\begin{aligned} & \mathcal{N}(\{n_{ab,\alpha}\}, \{n_{a,\beta,k}\}, \{\bar{n}_{a,\gamma,k}\}) \\ &= \sum_{\left\{ \substack{R_a \vdash n_a \\ l(R_a) \leq N_a} \right\}} \sum_{\{r_{ab,\alpha} \vdash n_{ab,\alpha}\}} \prod_a g(\cup_{b,\alpha} r_{ab,\alpha} \cup_{\beta,k} [n_{a,\beta,k}]; R_a) g(\cup_{b,\alpha} r_{ba,\alpha} \cup_{\gamma,k} [\bar{n}_{a,\gamma,k}]; R_a) \end{aligned} \quad (2.2.18)$$

where $n_a = \sum_{b,\alpha} n_{ab,\alpha} + \sum_{\beta,k} n_{a,\beta,k}$.

We can give a pictorial interpretation of the counting function (2.2.18) as follows.

- i)* Choose the set of integers $\cup_{a,b,\alpha} \{n_{ab,\alpha}\} \cup_{a,\beta,k} \{n_{a,\beta,k}\} \cup_{a,\gamma,k} \{\bar{n}_{a,\gamma,k}\}$. These determine the numbers of elementary fields of various types in the composite operators under consideration.
- ii)* To all edges joining the gauge node a to the gauge node b , associate a representation $r_{ab,\alpha}$ of the symmetric group $S_{n_{ab,\alpha}}$.
- iii)* Divide each gauge node a into two components, a^+ and a^- : the former collects all the edges coming into the node a , while the latter collects all the edges leaving the node a . Connect a^+ to a^- by adding a directed edge carrying a representation R_a of S_{n_a} , where $n_a = \sum_{b,\alpha} n_{ab,\alpha} + \sum_{\beta,k} n_{a,\beta,k}$. The result is called *split-node* quiver.
- iiii)* To each a^- attach the Littlewood-Richardson coefficient $g(\cup_{b,\alpha} r_{ab,\alpha} \cup_{\beta,k} [n_{a,\beta,k}]; R_a)$; to each a^+ attach the Littlewood-Richardson coefficient $g(\cup_{b,\alpha} r_{ba,\alpha} \cup_{\gamma,k} [\bar{n}_{a,\gamma,k}]; R_a)$.
- iv)* Take the product of all the Littlewood-Richardson coefficients obtained in the previous step and sum over all possible representations $\{R_a\}$ and $\{r_{ab,\alpha}\}$, imposing finite N constraints $l(R_a) \leq N_a$ at each gauge node a .

As an example of the application of (2.2.14), consider an $\mathcal{N} = 2$ SQCD with an adjoint hypermultiplet. The $\mathcal{N} = 1$ quiver diagram for this gauge theory and its corresponding split node quiver are depicted in figure 9.

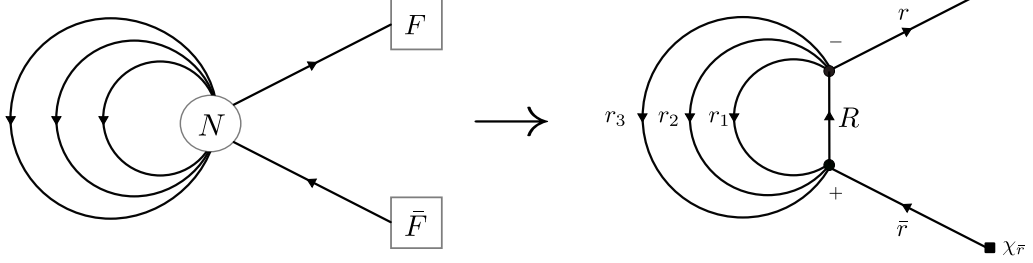

Figure 9: The $\mathcal{N} = 1$ quiver and the corresponding split node diagram for a $\mathcal{N} = 2$ SQCD with an adjoint hypermultiplet.

The generating function for this model can then be readily obtained using (2.2.14):

$$\begin{aligned} \mathcal{Z}(x_1, x_2, x_3, \mathcal{T}, \bar{\mathcal{T}}) &= \sum_{n_1, n_2, n_3=0}^{\infty} \sum_{n, \bar{n}=0}^{\infty} x_1^{n_1} x_2^{n_2} x_3^{n_3} \\ &\times \sum_{\substack{R \vdash m \\ l(R) \leq N}} \sum_{\substack{r_1 \vdash n_1 \\ r_2 \vdash n_2 \\ r_3 \vdash n_3}} \sum_{\substack{r \vdash n \\ \bar{r} \vdash \bar{n}}} g(r_1, r_2, r_3, r; R) g(r_1, r_2, r_3, \bar{r}; R) \chi_r(\mathcal{T}) \chi_{\bar{r}}(\bar{\mathcal{T}}) \end{aligned} \quad (2.2.19)$$

with $m = n_1 + n_2 + n_3 + n = n_1 + n_2 + n_3 + \bar{n}$. On the other hand, using (2.2.18) we can write the counting function

$$\begin{aligned} &\mathcal{N}(n_1, n_2, n_3, \{n_j\}, \{\bar{n}_k\}) \\ &= \sum_{\substack{R \vdash m \\ l(R) \leq N}} \sum_{\substack{r_1 \vdash n_1 \\ r_2 \vdash n_2 \\ r_3 \vdash n_3}} g(r_1, r_2, r_3, [n_1], [n_2], \dots, [n_F]; R) g(r_1, r_2, r_3, [\bar{n}_1], [\bar{n}_2], \dots, [\bar{n}_{\bar{F}}]; R) \end{aligned} \quad (2.2.20)$$

so that

$$\begin{aligned} \mathcal{Z}(x_1, x_2, x_3, \{t_j\}, \{\bar{t}_k\}) &= \sum_{n_1, n_2, n_3} \sum_{\{n_j\}} \sum_{\{\bar{n}_k\}} \mathcal{N}(n_1, n_2, n_3, \{n_j\}, \{\bar{n}_k\}) \\ &\times x_1^{n_1} x_2^{n_2} x_3^{n_3} \left(\prod_{j=1}^F t_j^{n_j} \right) \left(\prod_{k=1}^{\bar{F}} \bar{t}_k^{\bar{n}_k} \right) \end{aligned} \quad (2.2.21)$$

Let us now consider the flavoured conifold gauge theory [52, 53, 75, 76], whose quiver is depicted in figure 10:

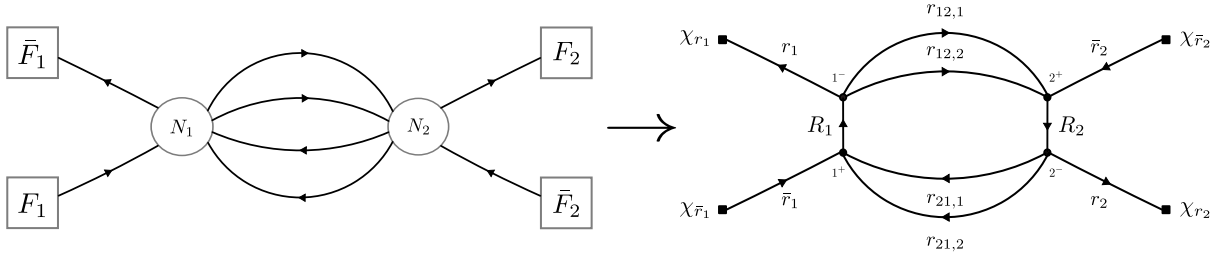

Figure 10: The flavoured conifold quiver and its split node quiver.

Applying (2.2.14), we find that the generating function for the flavoured conifold is

$$\begin{aligned}
 & \mathcal{Z}(x_{12,1}, x_{12,2}, x_{21,1}, x_{21,2}, \mathcal{T}_1, \mathcal{T}_2, \bar{\mathcal{T}}_1, \bar{\mathcal{T}}_2) \\
 &= \sum_{n_{12,1}, n_{12,2}=0}^{\infty} \sum_{n_{21,1}, n_{21,2}=0}^{\infty} x_{12,1}^{n_{12,1}} x_{12,2}^{n_{12,2}} x_{21,1}^{n_{21,1}} x_{21,2}^{n_{21,2}} \sum_{\substack{R_1 \vdash m_1 \\ l(R_1) \leq N_1}} \sum_{\substack{R_2 \vdash m_2 \\ l(R_2) \leq N_2}} \sum_{\substack{r_{12,1} \vdash n_{12,1} \\ r_{12,2} \vdash n_{12,2}}} \sum_{\substack{r_{21,1} \vdash n_{21,1} \\ r_{21,2} \vdash n_{21,2}}} \sum_{\substack{r_1 \vdash n_1 \\ \bar{r}_1 \vdash \bar{n}_1}} \sum_{\substack{r_2 \vdash n_2 \\ \bar{r}_2 \vdash \bar{n}_2}} \\
 & \quad \times g(r_{12,1}, r_{12,2}, r_1; R_1) g(r_{21,1}, r_{21,2}, \bar{r}_1; R_1) \chi_{r_1}(\mathcal{T}_1) \chi_{\bar{r}_1}(\bar{\mathcal{T}}_1) \\
 & \quad \times g(r_{21,1}, r_{21,2}, r_2; R_2) g(r_{12,1}, r_{12,2}, \bar{r}_2; R_2) \chi_{r_2}(\mathcal{T}_2) \chi_{\bar{r}_2}(\bar{\mathcal{T}}_2) \tag{2.2.22}
 \end{aligned}$$

where $m_1 = n_{12,1} + n_{12,2} + n_1 = n_{21,1} + n_{21,2} + \bar{n}_1$ and $m_2 = n_{21,1} + n_{21,2} + n_2 = n_{12,1} + n_{12,2} + \bar{n}_2$. As in the previous example, using (2.2.18) we get

$$\begin{aligned}
 & \mathcal{N}(n_{12,1}, n_{12,2}, n_{21,1}, n_{21,2}, \{n_{1,j}\}, \{n_{2,j}\}, \{\bar{n}_{1,k}\}, \{\bar{n}_{2,k}\}) = \sum_{\substack{R_1 \vdash m_1 \\ l(R_1) \leq N_1}} \sum_{\substack{R_2 \vdash m_2 \\ l(R_2) \leq N_2}} \sum_{\substack{r_{12,1} \vdash n_{12,1} \\ r_{12,2} \vdash n_{12,2}}} \sum_{\substack{r_{21,1} \vdash n_{21,1} \\ r_{21,2} \vdash n_{21,2}}} \\
 & \quad \times g(r_{12,1}, r_{12,2}, [n_{1,1}], [n_{1,2}], \dots, [n_{1,F_1}]; R_1) g(r_{21,1}, r_{21,2}, [\bar{n}_{1,1}], [\bar{n}_{1,2}], \dots, [\bar{n}_{1,\bar{F}_1}]; R_1) \\
 & \quad \times g(r_{21,1}, r_{21,2}, [n_{2,1}], [n_{2,2}], \dots, [n_{2,F_2}]; R_2) g(r_{12,1}, r_{12,2}, [\bar{n}_{2,1}], [\bar{n}_{2,2}], \dots, [\bar{n}_{2,\bar{F}_2}]; R_2) \tag{2.2.23}
 \end{aligned}$$

so that

$$\begin{aligned}
 & \mathcal{Z}(x_{12,1}, x_{12,2}, x_{21,1}, x_{21,2}, \{t_{1,j}\}, \{t_{2,j}\}, \{\bar{t}_{1,k}\}, \{\bar{t}_{2,k}\}) \\
 &= \sum_{\substack{n_{12,1} \\ n_{12,2}}} \sum_{\substack{n_{21,1} \\ n_{21,2}}} \sum_{\{n_{1,j}\}} \sum_{\{n_{2,j}\}} \sum_{\{\bar{n}_{1,k}\}} \sum_{\{\bar{n}_{2,k}\}} \mathcal{N}(n_{12,1}, n_{12,2}, n_{21,1}, n_{21,2}, \{n_{1,j}\}, \{n_{2,j}\}, \{\bar{n}_{1,k}\}, \{\bar{n}_{2,k}\}) \\
 & \quad \times x_{12,1}^{n_{12,1}} x_{12,2}^{n_{12,2}} x_{21,1}^{n_{21,1}} x_{21,2}^{n_{21,2}} \left(\prod_{j=1}^{F_1} t_{1,j}^{n_{1,j}} \right) \left(\prod_{j=1}^{F_2} t_{2,j}^{n_{2,j}} \right) \left(\prod_{k=1}^{\bar{F}_1} \bar{t}_{1,k}^{\bar{n}_{1,k}} \right) \left(\prod_{k=1}^{\bar{F}_2} \bar{t}_{2,k}^{\bar{n}_{2,k}} \right) \tag{2.2.24}
 \end{aligned}$$

All of the previous formulae hold for any N . In the next section we will drop the $l(R_a) \leq N_a$

constraints, $\forall a$, to focus on the large N case.

2.2.1 The generating function \mathcal{Z} and the building block $F^{[n]}$

Let us take the large N limit, for all the gauge groups of the theory. In appendix B.1.1 we show that $\mathcal{Z}(\{x_{ab,\alpha}\}, \{\mathcal{T}_{a,\beta}\}, \{\bar{\mathcal{T}}_{a,\gamma}\})$ can be written as the multiple sum

$$\begin{aligned} \mathcal{Z} &= \sum_{\mathbf{p}} \prod_i \prod_a \left(\prod_{b,\alpha} \frac{x_{ab,\alpha}^{n_{ab,\alpha}}}{p_{ab,\alpha}^{(i)}} \right) \left(\prod_{\beta} \frac{(\text{Tr } \mathcal{T}_{a,\beta}^i)^{p_{a,\beta}^{(i)}}}{p_{a,\beta}^{(i)}} \right) \left(\prod_{\gamma} \frac{(\text{Tr } \bar{\mathcal{T}}_{a,\gamma}^i)^{\bar{p}_{a,\gamma}^{(i)}}}{\bar{p}_{a,\gamma}^{(i)}} \right) \\ &\times \frac{(\sum_{b,\alpha} p_{ab,\alpha}^{(i)} + \sum_{\beta} p_{a,\beta}^{(i)})!}{i^{\sum_{\beta} p_{a,\beta}^{(i)}}} \delta_a \left(\sum_{b,\alpha} (p_{ab,\alpha}^{(i)} - \bar{p}_{ba,\alpha}^{(i)}) + \sum_{\beta} p_{a,\beta}^{(i)} - \sum_{\gamma} \bar{p}_{a,\gamma}^{(i)} \right) \end{aligned} \quad (2.2.25)$$

where $\mathbf{p} = \cup_{ab,\alpha} \vec{p}_{ab,\alpha} \cup_{a,\beta} \vec{p}_{a,\beta} \cup_{a,\gamma} \vec{\bar{p}}_{a,\gamma}$, and the vectors $\vec{p}_{ab,\alpha}$, $\vec{p}_{a,\beta}$, $\vec{\bar{p}}_{a,\gamma}$ are defined in (2.2.6).

Crucially, we can now define the quantity

$$\begin{aligned} F^{[n]}(\{x_{ab}\}, \{t_a\}, \{\bar{t}_a\}) &= \sum_{\vec{p}} \prod_{a=1}^n \left(\sum_{b=1}^n p_{ba} + \bar{p}_a \right)! \delta_a \left(\sum_{b=1}^n (p_{ab} - p_{ba}) + p_a - \bar{p}_a \right) \\ &\times \left(\prod_{b=1}^n \frac{x_{ab}^{p_{ab}}}{p_{ab}!} \right) \left(\frac{t_a^{p_a}}{p_a!} \right) \left(\frac{\bar{t}_a^{\bar{p}_a}}{\bar{p}_a!} \right) \end{aligned} \quad (2.2.26)$$

with $\vec{p} = \cup_{a,b} \{p_{ab}\} \cup_a \{p_a, \bar{p}_a\}$, such that

$$\begin{aligned} \mathcal{Z}(\{x_{ab,\alpha}\}, \{\mathcal{T}_{a,\beta}\}, \{\bar{\mathcal{T}}_{a,\gamma}\}) &= \prod_i F^{[n]} \left(\left\{ x_{ab} \rightarrow \sum_{\alpha} x_{ab,\alpha}^i \right\}, \left\{ t_a \rightarrow \sum_{\beta} \frac{\text{Tr}(\mathcal{T}_{a,\beta}^i)}{i} \right\}, \left\{ \bar{t}_a \rightarrow \sum_{\gamma} \text{Tr}(\bar{\mathcal{T}}_{a,\gamma}^i) \right\} \right) \end{aligned} \quad (2.2.27)$$

From this equation we see that $F^{[n]}$ is the building block of \mathcal{Z} . Note that the t coefficients in the RHS of (2.2.27) are weighted by a i^{-1} coefficient, while the \bar{t} coefficients are not: in section 2.5 we will derive a more symmetric version of this formula, where the weighting for chemical potentials of the quark and antiquark field is the same.

In appendix B.1.2 we derive an expression for $F^{[n]}$ in terms of contour integrals, namely

$$F^{[n]}(\{x_{ab}\}, \{t_a\}, \{\bar{t}_a\}) = \left(\prod_{a=1}^n \oint_{\mathcal{C}_a} \frac{dz_a}{2\pi i} \right) \prod_{a=1}^n I_a(\vec{z}; \vec{x}_a, t_a, \bar{t}_a), \quad (2.2.28)$$

in which

$$\vec{z} = (z_1, z_2, \dots, z_n), \quad \vec{x}_a = (x_{1a}, x_{2a}, \dots, x_{na}) \quad (2.2.29)$$

and

$$I_a(\vec{z}; \vec{x}_a, t_a, \bar{t}_a) = \frac{\exp(z_a t_a)}{z_a - (\bar{t}_a + \sum_b z_b x_{ba})} \quad (2.2.30)$$

We also obtained a pole prescription for the computation of these contour integrals: in the appendices B.1 and B.2 we explain that only the z_a pole coming from the I_a term in the integrand has to be enclosed by \mathcal{C}_a .

As a last remark, note that all the variables $z_a, x_{ab}, t_a, \bar{t}_a$ in eq. (2.2.28) are charged under the $\prod_{a=1}^n U(1)_a \subset \prod_{a=1}^n U(N_a)$ subgroup of the theory as in table 2.

Variable	Charge	Subgroup of $\prod_a U(1)_a$
x_{ab}	$(-1, 1)$	$U(1)_a \times U(1)_b$
t_a	-1	$U(1)_a$
\bar{t}_a	1	$U(1)_a$
z_a	1	$U(1)_a$

Table 2: $U(1)$ charges of the variables appearing in $F^{[n]}$.

The charge for the x_{ab} coefficients comes from the fact that these variables are associated to fields leaving node a and joining node b , thus transforming under (\bar{N}_a, N_b) in the original theory. Similar comments holds for the charges of t_a and \bar{t}_a , while the charge for z_a has been chosen in such a way that the function $F^{[n]}$ is neutral under $\prod_a U(1)_a$, as it should be.

For completeness, let us write down the contour integral formulation for \mathcal{Z} , which can be immediately obtained from (2.2.26) by means of (2.2.27), and reads

$$\mathcal{Z} = \prod_i \left(\prod_a \oint_{\mathcal{C}_{a,i}} \frac{dz_{a,i}}{2\pi i z_{a,i}} \right) \prod_a \frac{\exp\left(\frac{z_{a,i} \sum_\beta \text{Tr}(\mathcal{T}_{a,\beta}^i)}{i}\right)}{1 - z_{a,i}^{-1} \left(\sum_\gamma \text{Tr}(\bar{\mathcal{T}}_{a,\gamma}^i) + \sum_{b,\alpha} z_{b,i} x_{ba,\alpha}^i \right)} \quad (2.2.31)$$

The simplification coming from using $F^{[n]}$ in place of the latter is evident.

2.3 The unflavoured case: contour integrals and paths on graphs

We now have to calculate the contour integral in $F^{[n]}$, that is, calculate residues. In an n -node quiver, each z_a variable has n poles, but not all of them have to be included in the contour \mathcal{C}_a . The constraints from the convergence of the sums in appendix B.1.2 instruct us on which poles to pick and which ones to discard. In appendix B.2 we show that they indeed give us a very simple and intuitive prescription: *for all a , only the z_a pole coming from the I_a integrand has to be enclosed by \mathcal{C}_a .*

We consider here the case in which we set $t_a = \bar{t}_a = 0 \forall a$ in (2.2.28), to get the quantity

$$F^{[n]}(\{x_{ab}\}, 0, 0) \equiv F_0^{[n]}(\{x_{ab}\}) = \left(\prod_a \oint_{\mathcal{C}_a} \frac{dz_a}{2\pi i} \right) \prod_a I_a(\vec{z}; \vec{x}_a) \quad (2.3.1)$$

where

$$I_a(\vec{z}; \vec{x}_a) = \frac{1}{z_a - \sum_b z_b x_{b,a}} \quad (2.3.2)$$

Recall that $I_a(\vec{z}; \vec{x}_a)$ is a shorthand, which it will now be convenient to expand:

$$I_a(\vec{z}; \vec{x}_a) = I_a(z_1, z_2, \dots, z_n; \vec{x}_a) \quad (2.3.3)$$

so that we can rewrite (2.3.1) as

$$F_0^{[n]}(\{x_{ab}\}) = \left(\prod_a \oint_{\mathcal{C}_a} \frac{dz_a}{2\pi i} \right) \prod_a I_a(z_1, z_2, \dots, z_n; \vec{x}_a) \quad (2.3.4)$$

We want to compute contour integrals in eq. (2.3.4). Let us choose an ordering in which to compute such integrals: we choose the simplest one, that is we integrate over $z_1, z_2, \dots, z_i, z_{i+1}, \dots, z_n$ in this precise order. We will refer to this ordering as the ‘natural ordering’. With the pole prescription discussed in appendix B.2, the z_a integration picks up the z_a pole in the I_a integrand only. Then, after the first integral (the z_1 integral with our ordering choice) has been computed, eq. (2.3.4) becomes

$$F_0^{[n]}(\{x_{ab}\}) = H_1(\vec{x}) \left(\prod_{a>1} \oint_{\mathcal{C}_a} \frac{dz_a}{2\pi i} \right) \prod_{a>1} I_a(z_1^*, z_2, \dots, z_n; \vec{x}_a) \quad (2.3.5)$$

where we introduced the H_1 coefficient, outcome of the residue calculation, that depends only on the x variables. After the integration has been done, z_1 is replaced by its pole equation

$$z_1^* = z_1^*(z_2, z_3, \dots, z_n; \vec{x}) \quad (2.3.6)$$

in all of the remaining integrands I_a ($a > 1$). The explicit form

$$z_1^*(z_2, z_3, \dots, z_n; \vec{x}) = \frac{1}{(1 - x_{1,1})} \sum_{b=2}^n z_b x_{b,1} \quad (2.3.7)$$

comes from solving $I_1^{-1}(\vec{z}; \vec{x}_1) = 0$ for z_1 . In the second step, we can solve $I_2^{-1}(z_1 \rightarrow z_1^*, z_2, z_3, \dots, z_n) = 0$, which gives

$$z_2^* = \frac{1}{(1 - x_{1,1})(1 - x_{2,2}) - x_{1,2}x_{2,1}} \sum_{b=3}^n \left(x_{b,2} + \frac{x_{b,1}x_{1,2}}{1 - x_{1,1}} \right) \quad (2.3.8)$$

In the next step, we calculate $I_3^{-1}(z_1 \rightarrow z_1^*, z_2 \rightarrow z_2^*, z_3, z_4 \cdots, z_n)$ and we solve $I_3^{-1} = 0$ to calculate $z_3^*(z_4, z_5, \cdots, z_n)$.

Generally, the explicit equation for each of the z_j^* ($1 \leq j \leq n$) comes from solving for z_j the equation

$$I_j^{-1}(z_1^*, z_2^*, \dots, z_{j-1}^*, z_j, z_{j+1}, \dots, z_n; \vec{x}) = 0 \quad (2.3.9)$$

for each j . These pole equations are of the form

$$z_j^*(z_{j+1}, z_{j+2}, \dots, z_n; \vec{x}) = \sum_{i>j} z_i a_{i,j} \quad (2.3.10)$$

for some coefficients $a_{i,j}$, which are functions of \vec{x} . It is useful however to introduce a different equation for the poles z_j^* . Note that z_j^* is a function of the set $\{z_{j+1}, z_{j+2}, \dots, z_n\}$. If r integrations have already been done, then the z_j^* pole equations, with $j \leq r$, can be expressed in terms of the remaining set of z_a , that is $\{z_{r+1}, z_{r+2} \cdots, z_n\}$. The variables z_k ($j \leq k \leq r$) appearing in (2.3.10) can be substituted with their respective pole equations z_k^* . We can thus write

$$\begin{aligned} z_j^*(z_{j+1}^*, z_{j+2}^*, \dots, z_r^*, z_{r+1}, \dots, z_n; \vec{x}) \\ = \sum_{i>r} z_i a_{i,j} + \sum_{\lambda=j+1}^r z_\lambda^*(z_{\lambda+1}^*, z_{\lambda+2}^*, \dots, z_r^*, z_{r+1}, \dots, z_n; \vec{x}) a_{\lambda,j} \end{aligned} \quad (2.3.11)$$

Repeated substitutions to eliminate the variables z_k^* in favour of $z_{k'}^*$, for $k < k' \leq r$, will lead to an expression of the form

$$z_\lambda^{*[r]} = z_\lambda^*(z_{r+1}, \dots, z_n; \vec{x}) = \sum_{i>r} z_i \hat{a}_{i,\lambda}^{[r]}, \quad \lambda \leq r \quad (2.3.12)$$

for some new $\hat{a}^{[r]}$ coefficients, functions of \vec{x} , that we call *pole coefficients*. Inserting this equation in (2.3.11) gives a recursive relation for $\hat{a}_{i,j}^{[r]}$:

$$\hat{a}_{i,j}^{[r]} = a_{i,j} + \sum_{\lambda=j+1}^r \hat{a}_{i,\lambda}^{[r]} a_{\lambda,j}, \quad i > r, \quad j \leq r \leq n-1 \quad (2.3.13a)$$

There is no $\hat{a}^{[n]}$ coefficient, as can be seen from (2.3.12). We will in fact observe that $z_n^* = 0$.

Comparing (2.3.10) and (2.3.12) gives

$$\hat{a}_{i,r}^{[r]} = a_{i,r}, \quad i > r \quad (2.3.13b)$$

and we will shortly derive

$$a_{i,r} = \frac{x_{i,r} + \sum_{k=1}^{r-1} \hat{a}_{i,k}^{[r-1]} x_{k,r}}{1 - \left(x_{r,r} + \sum_{k=1}^{r-1} \hat{a}_{r,k}^{[r-1]} x_{k,r} \right)}, \quad i > r \quad (2.3.14)$$

Now, for fixed r , all of the $z_j^{*[r]}$ equations ($1 \leq j \leq r$) in (2.3.12) will be functions of the same set of z_a , that is $\{z_k, r < k \leq n\}$. With this notation, after r integrations have been done, $F_0^{[n]}$ will read

$$F_0^{[n]} = \prod_{j=1}^r H_j(\vec{x}) \left(\prod_{a>r} \oint_{\mathcal{C}_a} \frac{dz_a}{2\pi i} \right) \prod_{a>r} I_a \left(z_1^{*[r]}, z_2^{*[r]}, \dots, z_r^{*[r]}, z_{r+1}, z_{r+2}, \dots, z_n; \vec{x}_a \right) \quad (2.3.15)$$

where explicitly

$$I_a \left(z_1^{*[r]}, z_2^{*[r]}, \dots, z_r^{*[r]}, z_{r+1}, z_{r+2}, \dots, z_n; \vec{x}_a \right) = \frac{1}{z_a - \left(\sum_{b>r} z_b x_{b,a} + \sum_{i=1, \dots, r} z_i^{*[r]} x_{i,a} \right)} \quad (2.3.16)$$

Going back to eq. (2.3.15), suppose we want now to calculate the z_{r+1} integral. Consider then the equation

$$\begin{aligned} I_{r+1}^{-1} \left(z_1^{*[r]}, z_2^{*[r]}, \dots, z_r^{*[r]}, z_{r+1}, z_{r+2}, \dots, z_n; \vec{x}_{r+1} \right) \\ = z_{r+1} - \left(\sum_{b>r} z_b x_{b,r+1} + \sum_{i=1}^r z_i^{*[r]} x_{i,r+1} \right) = 0 \end{aligned} \quad (2.3.17)$$

and let us solve it for z_{r+1} . We have

$$\begin{aligned} (1 - x_{r+1,r+1})z_{r+1} &= \sum_{b>r+1} z_b x_{b,r+1} + \sum_{i=1}^r z_i^{*[r]} x_{i,r+1} \\ &= \sum_{b>r+1} z_b x_{b,r+1} + \sum_{i=1}^r \sum_{j>r} z_j \hat{a}_{j,i}^{[r]} x_{i,r+1} \\ &= \sum_{j>r+1} z_j \left(x_{j,r+1} + \sum_{i=1}^r \hat{a}_{j,i}^{[r]} x_{i,r+1} \right) + \sum_{i=1}^r z_{r+1} \hat{a}_{r+1,i}^{[r]} x_{i,r+1} \end{aligned} \quad (2.3.18)$$

Collecting terms we get

$$\begin{aligned} & \left(1 - \left(x_{r+1,r+1} + \sum_{i=1}^r \hat{a}_{r+1,i}^{[r]} x_{i,r+1} \right) \right) z_{r+1} = \\ & = \sum_{j>r+1} z_j \left(x_{j,r+1} + \sum_{i=1}^r \hat{a}_{j,i}^{[r]} x_{i,r+1} \right) \end{aligned} \quad (2.3.19)$$

so that we can finally write

$$z_{r+1}^* = \sum_{j>r+1} z_j \frac{x_{j,r+1} + \sum_{i=1}^r \hat{a}_{j,i}^{[r]} x_{i,r+1}}{1 - \left(x_{r+1,r+1} + \sum_{i=1}^r \hat{a}_{r+1,i}^{[r]} x_{i,r+1} \right)} = \sum_{j>r+1} z_j a_{j,r+1} \quad (2.3.20)$$

Recalling the definition of the pole coefficients $\hat{a}_{i,\lambda}^{[r]}$ from (2.3.12) and substituting $r \rightarrow r-1$, this proves eq. (2.3.14). It also shows that $z_n^* = 0$, as there is no z_j with $j > n$ to sum over.

Inserting this result in (2.3.15) we get

$$\begin{aligned} F_0^{[n]} &= \prod_{j=1}^r H_j(\vec{x}) \left(\prod_{a>r} \oint_{\mathcal{C}_a} \frac{dz_a}{2\pi i} \right) \\ & \times \frac{1}{\left(1 - \left(x_{r+1,r+1} + \sum_{i=1}^r \hat{a}_{r+1,i}^{[r]} x_{i,r+1} \right) \right) z_{r+1} - \sum_{j \neq 1, \dots, r, r+1} z_j \left(x_{j,r+1} + \sum_{i=1}^r \hat{a}_{j,i}^{[r]} x_{i,r+1} \right)} \\ & \times \prod_{a>r+1} I_a(z_1^{*[r]}, z_2^{*[r]}, \dots, z_r^{*[r]}, z_{r+1}, z_{r+2}, \dots, z_n; \vec{x}_a) \\ &= \prod_{j=1}^r H_j(\vec{x}) \frac{1}{1 - \left(x_{r+1,r+1} + \sum_{i=1}^r \hat{a}_{r+1,i}^{[r]} x_{i,r+1} \right)} \oint_{\mathcal{C}_{r+1}} \frac{dz_{r+1}}{2\pi i} \frac{1}{z_{r+1} - z_{r+1}^*} \\ & \times \left(\prod_{a>r+1} \oint_{\mathcal{C}_a} \frac{dz_a}{2\pi i} \right) \prod_{a>r+1} I_a(z_1^{*[r]}, z_2^{*[r]}, \dots, z_r^{*[r]}, z_{r+1}, z_{r+2}, \dots, z_n; \vec{x}_a) \\ & \equiv \prod_{j=1}^{r+1} H_j(\vec{x}) \left(\prod_{a>r+1} \oint_{\mathcal{C}_a} \frac{dz_a}{2\pi i} \right) \prod_{a>r+1} I_a(z_1^{*[r+1]}, z_2^{*[r+1]}, \dots, z_r^{*[r+1]}, z_{r+1}^{*[r+1]}, z_{r+2}, \dots, z_n; \vec{x}_a) \end{aligned} \quad (2.3.21)$$

where we called, in agreement with our initial definitions,

$$H_{r+1}(\vec{x}) = \left[1 - \left(x_{r+1,r+1} + \sum_{i=1}^r \hat{a}_{r+1,i}^{[r]} x_{i,r+1} \right) \right]^{-1} \quad (2.3.22)$$

It is clear now that once all the integration have been done, $F_0^{[n]}$ will simply be the product

$$F_0^{[n]} = \prod_{i=1}^n H_i(\vec{x}) = \prod_{i=1}^n \left(1 - x_{i,i} - \sum_{q=1}^{i-1} \hat{a}_{i,q}^{[i-1]} x_{q,i} \right)^{-1} \quad (2.3.23)$$

In appendix B.3 we present an explicit example of the application of these formulae to a three node unflavoured quiver. From the last equation we can see how the pole coefficients $\hat{a}_{i,q}^{[i-1]}$ play a central role in the computation of $F_0^{[n]}$. Our goal now is to rewrite them in a more compact and appealing form. For notational purposes it is useful now to define $G_{[n]}$ as the inverse of $F_0^{[n]}$; $G_{[n]} = \left(F_0^{[n]} \right)^{-1}$.

Choosing any $1 \leq r < n$, for all $n \geq p > r$ and $1 \leq k \leq r$ we find an expression which can be interpreted in terms of paths on the complete n -node quiver:

$$\begin{aligned} G_{[r]} \hat{a}_{p,k}^{[r]} &= G_{[r] \setminus \{k\}} x_{p,k} + \sum_{\substack{i=1 \\ i \neq k}}^r G_{[r] \setminus \{k,i\}} x_{p,i} x_{i,k} + \sum_{\substack{i,j=1 \\ i \neq j \neq k}}^r G_{[r] \setminus \{k,i,j\}} x_{p,i} x_{i,j} x_{j,k} \\ &+ \dots + \sum_{\substack{i_1, i_2, \dots, i_t=1 \\ i_1 \neq i_2 \neq \dots \neq i_t \neq k}}^r G_{[r] \setminus \{k, \cup_{h=1}^t i_h\}} x_{p,i_1} x_{i_1, i_2} x_{i_2, i_3} \cdots x_{i_{t-1}, i_t} x_{i_t, k} + \dots \\ &\dots + \sum_{\substack{i_1, i_2, \dots, i_{r-1}=1 \\ i_1 \neq i_2 \neq \dots \neq i_{r-1} \neq k}}^r x_{p, i_1} x_{i_1, i_2} x_{i_2, i_3} \cdots x_{i_{r-2}, i_{r-1}} x_{i_{r-1}, k} \end{aligned} \quad (2.3.24)$$

or, in a more compact form:

$$G_{[r]} \hat{a}_{p,k}^{[r]} = \sum_{t=0}^{r-1} \left(\sum_{\substack{i_1, i_2, \dots, i_t=1 \\ i_1 \neq i_2 \neq \dots \neq i_t \neq k}}^r G_{[r] \setminus \{k, \cup_{h=1}^t i_h\}} x_{p, i_1} x_{i_1, i_2} x_{i_2, i_3} \cdots x_{i_{t-1}, i_t} x_{i_t, k} \right) \quad (2.3.25)$$

with the convention that $G_{[0]} = 1$. We prove this formula in appendix B.4. For fixed $r < n$ we now describe the interpretation of each of the terms in the expansion of (2.3.25) as a path on the complete n -node quiver. Each term is a product of two different pieces. The first one is the G function of a quiver containing a certain subset $[r] \setminus \{k, \cup_{h=1}^t i_h\}$ of the first $[r] = \{1, 2, \dots, r\}$ nodes. The second one is a string of x_{ab} variables, which can be interpreted as an oriented open line on the quiver. It departs from a node p , which is *not* included in the set $[r]$, passes through some t intermediate nodes i_h and arrives at node k , with $i_1, i_2, \dots, i_t, k \in [r]$.

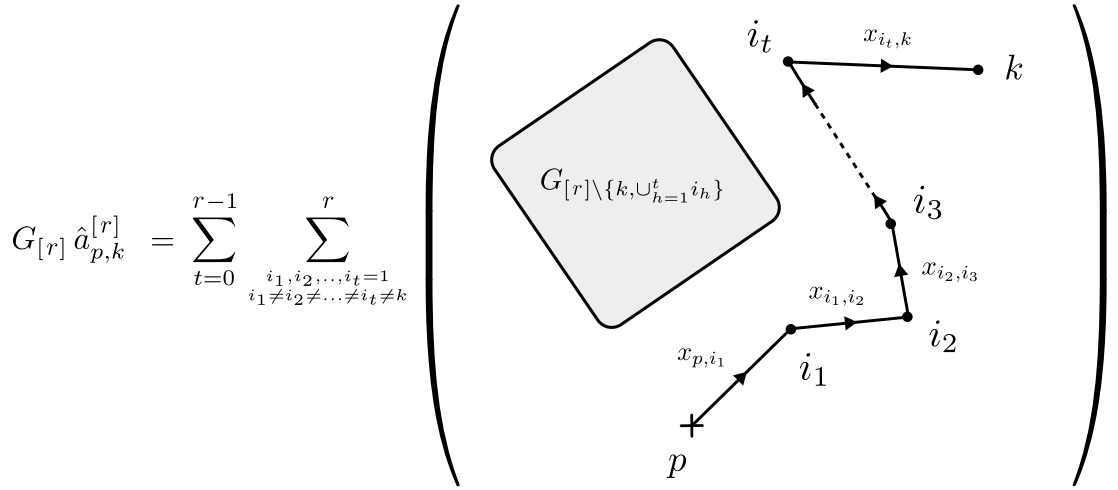

Figure 11: Pictorial interpretation of $G_{[r]} \hat{a}_{p,k}^{[r]}$. The starting point of the oriented open path, p , belongs to the set $\{r+1, r+2, \dots, n\}$.

From here we also explicitly see that the pole coefficient $\hat{a}_{p,k}^{[r]}$ is charged under the $U(1)^n$ subgroup of the gauge group of the quiver. Since every $G_{[r]}$ has zero $U(1)^n$ charge, and the product of x_{ab} coefficients $x_{p,i_1} x_{i_1,i_2} x_{i_2,i_3} \cdots x_{i_{t-1},i_t} x_{i_t,k}$ is charged under the p -th $U(1)$ and the k -th $U(1)$ as $(-1, 1)$ respectively, the whole quantity $\hat{a}_{p,k}^{[r]}$ will carry a $(-1, 1)$ charge under $U(1)_p \times U(1)_k$, just like an $x_{p,k}$ variable would. These quantities are also helpful in writing down a recursive formula for $G_{[r]}$. Note that $G_{[r+1]}$ can be written as

$$\begin{aligned} G_{[r+1]} &= G_{[r]} \left(1 - x_{r+1,r+1} - \sum_{k=1}^r \hat{a}_{r+1,k}^{[r]} x_{k,r+1} \right) \\ &= G_{[r]} (1 - x_{r+1,r+1}) - \sum_{k=1}^r G_{[r]} \hat{a}_{r+1,k}^{[r]} x_{k,r+1} \end{aligned} \quad (2.3.26)$$

The terms in the sum above are of the form (2.3.25), so that we can use it to bring $G_{[r+1]}$ into the form

$$\begin{aligned} G_{[r+1]} &= G_{[r]} (1 - x_{r+1,r+1}) \\ &\quad - \sum_{k=1}^r \sum_{t=0}^{r-1} \sum_{\substack{i_1, i_2, \dots, i_t=1 \\ i_1 \neq i_2 \neq \dots \neq i_t \neq k}}^r G_{[r] \setminus \{k, \cup_{h=1}^t i_h\}} x_{r+1,i_1} x_{i_1,i_2} x_{i_2,i_3} \cdots x_{i_{t-1},i_t} x_{i_t,k} x_{k,r+1} \end{aligned} \quad (2.3.27)$$

and after relabelling some summation variables, we can write the this equation as

$$G_{[r+1]} = G_{[r]} - G_{[r]}x_{r+1,r+1} - \sum_{t=1}^r \sum_{\substack{i_1, i_2, \dots, i_t=1 \\ i_1 \neq i_2 \neq \dots \neq i_t}}^r G_{[r] \setminus \{\cup_{h=1}^t i_h\}} x_{r+1, i_1} x_{i_1, i_2} x_{i_2, i_3} \cdots x_{i_{t-1}, i_t} x_{i_t, r+1} \quad (2.3.28)$$

and since the second term on the RHS of this identity is just the $t = 0$ term of the following sum, we finally have

$$G_{[r+1]} = G_{[r]} - \sum_{t=0}^r \sum_{\substack{i_1, i_2, \dots, i_t=1 \\ i_1 \neq i_2 \neq \dots \neq i_t}}^r G_{[r] \setminus \{\cup_{h=1}^t i_h\}} x_{r+1, i_1} x_{i_1, i_2} x_{i_2, i_3} \cdots x_{i_{t-1}, i_t} x_{i_t, r+1} \quad (2.3.29)$$

We can also give a similar formula for *each* of the H_l coefficients in the product (2.3.23). We know that

$$H_l(\vec{x}) = \left(1 - x_{l,l} - \sum_{q=1}^{l-1} \hat{a}_{l,q}^{[l-1]} x_{q,l} \right)^{-1} \quad (2.3.30)$$

and using $F_0^{[n]} = G_{[n]}^{-1}$ we can write

$$\begin{aligned} H_l(\vec{x}) &= \left(1 - F_0^{[l-1]} G_{[l-1]} x_{l,l} - F_0^{[l-1]} \sum_{q=1}^{l-1} G_{[l-1]} \hat{a}_{l,q}^{[l-1]} x_{q,l} \right)^{-1} \\ &= \left(1 - F_0^{[l-1]} \left(G_{[l-1]} x_{l,l} + \sum_{q=1}^{l-1} G_{[l-1]} \hat{a}_{l,q}^{[l-1]} x_{q,l} \right) \right)^{-1} \end{aligned} \quad (2.3.31)$$

We again have terms like $G_{[l-1]} \hat{a}_{l,q}^{[l-1]} x_{q,l}$, which have the same structure of the ones encountered in the derivation of eq. (2.3.29). We can just redo the same steps done previously to bring the equation for the $H_l(\vec{x})$ coefficient into the form

$$\begin{aligned} H_l(\vec{x}) &= \left(1 - F_0^{[l-1]} \sum_{t=0}^{l-1} \sum_{\substack{i_1, i_2, \dots, i_t=1 \\ i_1 \neq i_2 \neq \dots \neq i_t}}^{l-1} G_{[l-1] \setminus \{\cup_{h=1}^t i_h\}} x_{l, i_1} x_{i_1, i_2} x_{i_2, i_3} \cdots x_{i_{t-1}, i_t} x_{i_t, l} \right)^{-1} \\ &= F_0^{[l-1]} \left(G_{[l-1]} - \sum_{t=0}^{l-1} \sum_{\substack{i_1, i_2, \dots, i_t=1 \\ i_1 \neq i_2 \neq \dots \neq i_t}}^{l-1} G_{[l-1] \setminus \{\cup_{h=1}^t i_h\}} x_{l, i_1} x_{i_1, i_2} x_{i_2, i_3} \cdots x_{i_{t-1}, i_t} x_{i_t, l} \right)^{-1} \\ &= \frac{G_{[l-1]}}{G_{[l]}} \end{aligned} \quad (2.3.32)$$

where in the last step we used eq. (2.3.29). We can then rewrite eq. (2.3.23) as

$$F_0^{[n]} = \prod_{i=1}^n H_i(\vec{x}) = \prod_{i=1}^n \frac{G_{[i-1]}}{G_{[i]}} \quad (2.3.33)$$

with $G_{[0]} = 1$.

2.3.1 $F_0^{[n]}$ and the sum over subsets

In this section we will prove the expression for $(F_0^{[n]})^{-1}$ given in [26]

$$(F_0^{[n]})^{-1} = 1 + \sum_{\mathbb{V} \subseteq V_n} \sum_{\sigma \in \text{Sym}(\mathbb{V})} (-1)^{C_\sigma} y_\sigma(\{x_{ab}\}) \quad (2.3.34)$$

where \mathbb{V} is any subset of the set of nodes $V_n = \{1, 2, \dots, n\}$ of the quiver but the empty set, and $\text{Sym}(\mathbb{V})$ is the group of all the permutations of elements in \mathbb{V} . C_σ is the number of cycles in σ . $y_\sigma(\{x_{ab}\})$ is a monomial built from the x_{ab} coefficients as

$$y_\sigma(\{x_{ab}\}) = \prod_i y_{\sigma^{(i)}}(\{x_{ab}\}) \quad (2.3.35)$$

where the product runs over the cycles $\sigma^{(i)}$ of the permutation $\sigma = \prod_i \sigma^{(i)}$, and for a single cycle (i_1, i_2, \dots, i_k)

$$y_{(i_1, i_2, \dots, i_k)}(\{x_{ab}\}) = x_{i_1, i_2} x_{i_2, i_3} \cdots x_{i_k, i_1} \quad (2.3.36)$$

For example, when $\sigma = (12)(3)$, the permutation which swaps 1 and 2 and leaves 3 fixed, then $y_{(12)(3)}(\{x_{ab}\}) = x_{12} x_{21} x_{33}$. This equation has thus an interpretation in terms of *loops* $\{y_c\}$ on a complete quiver, where each loop y_c corresponds to a cycle $c = (i_1, \dots, i_k)$ as in (2.3.36). Since these loops corresponds to cyclic permutations, they do not visit the same node more than once: for this reason we call them *simple loops*, to distinguish them from more general closed paths. In the following we will write the above formula as $\tilde{G}_{[n]}$:

$$\tilde{G}_{[n]} = 1 + \sum_{\mathbb{V} \subseteq V_n} \sum_{\sigma \in \text{Sym}(\mathbb{V})} (-1)^{C_\sigma} y_\sigma(\{x_{ab}\}) \quad (2.3.37)$$

To prove the identity (2.3.34) we will show that the sequence $\tilde{G}_{[n]}$ obeys the same recursion relation (2.3.29) satisfied by the $G_{[n]}$ coefficients obtained from the residue computations. We have

$$\tilde{G}_{[n+1]} = 1 + \sum_{\mathbb{V} \subseteq \{1, \dots, n+1\}} \sum_{\sigma \in \text{Sym}(\mathbb{V})} (-1)^{C_\sigma} y_\sigma \quad (2.3.38)$$

If the subset \mathbb{V} of $\{1, \dots, n+1\}$ does not include $n+1$, we have a sum which, together with the leading 1, gives $G_{[n]}$. The remaining terms involve subsets which include the $\{n+1\}$ node.

For such subsets, the permutation σ can either be of the product form $\sigma'(n+1)$, where σ' is a permutation of $\{1, \dots, n\}$, or alternatively it is of the form $\sigma'(i_1, i_2, \dots, i_k, n+1)$, with σ' a permutation of $\{1, \dots, n\} \setminus \{i_1, \dots, i_k\}$. The first type of term gives

$$-\tilde{G}_{[n]}y_{n+1} = -\tilde{G}_{[n]}x_{n+1, n+1} \quad (2.3.39)$$

The second type of term gives

$$-\sum_{k=1}^n \sum_{i_1 \neq i_2 \neq \dots \neq i_k=1}^n \tilde{G}_{[n] \setminus \{i_1, \dots, i_k\}} y_{i_1, \dots, i_k, n+1} \quad (2.3.40)$$

Collecting the terms we find

$$\tilde{G}_{[n+1]} = \tilde{G}_{[n]}(1 - x_{n+1, n+1}) - \sum_{k=1}^n \sum_{i_1 \neq i_2 \neq \dots \neq i_k=1}^n \tilde{G}_{[n] \setminus \{i_1, \dots, i_k\}} x_{i_1 i_2} x_{i_2 i_3} \cdots x_{i_k, n+1} x_{n+1, i_1} \quad (2.3.41)$$

This proves that the guessed formula $\tilde{G}_{[n]}$ satisfies the same recursion relation as $G_{[n]}$. It is evident that $G_{[1]} = \tilde{G}_{[1]} = 1$. This proves that $\tilde{G}_{[n]} = G_{[n]}$, $\forall n$.

2.3.2 $F_0^{[n]}$ and determinants

Equation (2.3.34) can be used to recast $F_0^{[n]}(\{x_{ab}\})$ as a determinant expression given by

$$F_0^{[n]}(\{x_{ab}\}) = \frac{1}{\det(1_n - X_n)} \quad (2.3.42)$$

where 1_n is the n dimensional identity matrix and X_n is a $n \times n$ matrix defined by

$$X_n|_{ij} = x_{ij}, \quad 1 \leq (i, j) \leq n \quad (2.3.43)$$

The following identity for the expansion of $\det(1_n - X_n)$ in terms of sub-determinants of X_n , or equivalently characters of X_n associated with single-column Young diagrams, is useful:

$$\begin{aligned} \det(1_n - X_n) &= \sum_{k=0}^n (-1)^k \chi_{[1^k]}(X_n) \\ &= \sum_{k=0}^n (-1)^k \sum_{i_1, i_2, \dots, i_k=1}^n \sum_{\sigma \in S_k} \frac{(-1)^\sigma}{k!} x_{i_1 i_{\sigma(1)}} x_{i_2 i_{\sigma(2)}} \cdots x_{i_k i_{\sigma(k)}} \end{aligned} \quad (2.3.44)$$

This expansion is organized according to the number of 1 valued entries picked up from the matrix $(1_n - X_n)$ in calculating its determinant. When we pick $n - k$ of these 1 valued entries, we have the sum of the sub-determinants constructed from blocks of size k from the matrix X_n . The sign $(-1)^\sigma$ is the parity of the permutation. Because of the antisymmetrisation $\sum_{\sigma} (-1)^\sigma$, the sum over i_1, i_2, \dots, i_k can be restricted to run over the set $i_1 \neq i_2 \neq \dots \neq i_k$, so that it can be rewritten as a sum over subsets \mathbb{V}_k of k different integers from $\{1, \dots, n\}$. For each choice

of subset there is a factor of $k!$ for the different ways of assigning i_1, \dots, i_k to the elements of the subset. Hence

$$\det(1_n - X_n) = \sum_{k=0}^n (-1)^k \sum_{\mathbb{V}_k} \sum_{\sigma \in \text{Sym}(\mathbb{V}_k)} (-1)^{k-C_\sigma} y_\sigma \quad (2.3.45)$$

$\text{Sym}(\mathbb{V}_k)$ is the symmetric group of permutations of elements in \mathbb{V}_k . Here we have used the fact that the parity of a permutation σ can be written in terms of the number of cycles as $(-1)^\sigma = (-1)^{k-C_\sigma}$ and we also used the definition of y_σ . The expression (2.3.34) now follows.

2.4 Word counting and the building block $F_0^{[n]}$

The generating function $\mathcal{Z}(\{x_{ab;\alpha}\})$ for gauge invariant operators for unflavoured quiver theories has been given as an infinite product built from a building block $F_0^{[n]}(\{x_{ab}\})$. This has been expressed in terms of a determinant of the matrix $(1_n - X_n)$, where $(X_n)_{ab} = x_{ab}$.

After expanding $F_0^{[n]}(\{x_{ab}\})$ in a power series in the variables x_{ab} , it is natural to ask if the coefficients in this series have a combinatoric interpretation as counting something. The answer does not immediately follow from the combinatoric interpretation of $\mathcal{Z}(\{x_{ab;\alpha}\})$ in terms of gauge invariants, nevertheless, the coefficients in the expansion of $F_0^{[n]}(\{x_{ab}\})$ are themselves positive. This follows from the Cauchy-Littlewood formula for the expansion of the inverse determinant:

$$\frac{1}{\det(1_n - X_n)} = \sum_{k=0}^{\infty} \frac{1}{k!} \sum_{i_1 \dots i_k=1}^n \sum_{\sigma \in S_k} x_{i_1, i_{\sigma(1)}} x_{i_2, i_{\sigma(2)}} \dots x_{i_k, i_{\sigma(k)}} \quad (2.4.1)$$

This strongly suggests that there should be a combinatoric interpretation in terms of properties of graphs. We will find that there are in fact two combinatoric interpretations: both in terms of word counting related to the quiver with one directed edge for every specified start and end-point. We will call the latter the *complete n -node quiver*. We will refer to these two as the *charge conserving open string word (COSW) counting* problem and the *closed string word (CSW) counting* problem. It turns out that the equivalence between these two word counting problems is a known mathematical result! This gives a new connection between word counting problems and gauge theory.

To motivate the CSW interpretation, let us take the simple case of $n = 2$, for which we have

$$F_0^{[2]}(x_{11}, x_{12}, x_{21}, x_{22}) = \frac{1}{(1 - x_{11} - x_{22} - x_{12}x_{21} + x_{11}x_{22})} \quad (2.4.2)$$

The denominator depends on variables

$$y_{11} = x_{11}, \quad y_{12} = x_{12}x_{21}, \quad y_{22} = x_{22} \quad (2.4.3)$$

These variables are associated with closed loops in a graph with two nodes, and one edge for

every pair of specified starting and end points. Let us first set $y_{12} = 0$: we have

$$\frac{1}{(1 - y_{11} - y_{22} + y_{11}y_{22})} = \frac{1}{(1 - y_{11})} \frac{1}{(1 - y_{22})} \quad (2.4.4)$$

Expanding in powers of y_{11}, y_{22} , we see

$$\frac{1}{(1 - y_{11} - y_{22} + y_{11}y_{22})} = \sum_{m_1=0}^{\infty} y_{11}^{m_1} \sum_{m_2=0}^{\infty} y_{22}^{m_2} \quad (2.4.5)$$

We describe the CSW interpretation in this simple case. Take the letters $\hat{y}_{11}, \hat{y}_{22}$ and consider arbitrary strings of these, with the condition that

$$\hat{y}_{11}\hat{y}_{22} = \hat{y}_{22}\hat{y}_{11} \quad (2.4.6)$$

A general word is characterized by the number m_{11} and m_{22} of $\hat{y}_{11}, \hat{y}_{22}$. With these numbers specified, the commutation relation can be used to write any such word as

$$(\hat{y}_{11})^{m_{11}}(\hat{y}_{22})^{m_{22}} \quad (2.4.7)$$

There is thus, precisely one word with content (m_{11}, m_{22}) . Thus the coefficient of $y_{11}^{m_{11}}y_{22}^{m_{22}}$ is equal to the number of words in a language made from letters $\hat{y}_{11}, \hat{y}_{22}$. The words are sequences of these letters, with the commutation relation (2.4.6). Now set $y_{11} = 0$

$$\begin{aligned} F_0^{[2]}(y_{11} = 0, y_{12}, y_{22}) &= \frac{1}{(1 - y_{12} - y_{22})} = \sum_{m=0}^{\infty} (y_{12} + y_{22})^m = \sum_{m=0}^{\infty} \sum_{m_{12}=0}^m \frac{m!}{m_{12}!m_{22}!} y_{12}^{m_{12}} y_{22}^{m_{22}} \\ &= \sum_{m_{22}=0}^{\infty} \sum_{m_{12}=0}^{\infty} \frac{(m_{12} + m_{22})!}{m_{12}!m_{22}!} y_{12}^{m_{12}} y_{22}^{m_{22}} \end{aligned} \quad (2.4.8)$$

In this case, we can consider letters $\hat{y}_{12}, \hat{y}_{22}$, without imposing the commutation condition. Then a general word with specified numbers m_{12}, m_{22} is the number of sequences we can write with m_{12}, m_{22} copies of $\hat{y}_{12}, \hat{y}_{22}$. Each word corresponds to one way of placing the m_{12} objects of one kind and m_{22} objects of another kind in $m_{12} + m_{22}$ positions. This shows that the number of words is $\frac{(m_{12}+m_{22})!}{m_{12}!m_{22}!}$ in agreement with the coefficient above.

These simple examples illustrate a general interpretation of all the coefficients in the expansion of $F_0^{[n]}$, in terms of the cycle variables y_c . Consider the complete n -node quiver. To each simple closed loop c on the graph, associate a variable \hat{y}_c . If we label the nodes of the graph $\{1, \dots, n\}$, every cyclic permutation of a subset of the nodes corresponds to a simple loop on the graph. These simple loops visit each node no more than once. To define the CSWs, we associate a letter to \hat{y}_c to every simple loop. We impose the relation

$$\hat{y}_c\hat{y}_{c'} = \hat{y}_{c'}\hat{y}_c \quad (2.4.9)$$

for every pair of simple loops c, c' that have no node in common. The letters which do share a node are treated as non-commuting, while the letters that do not share a node are treated as commutative. Then we consider strings containing m_c copies of the letter \hat{y}_c . A simple guess, based on the above examples, is that the coefficient of $\prod_c y_c^{m_c}$ in the expansion of $F_0^{[n]}$ is exactly equal to the number of distinct words build from the letters \hat{y}_c with specified numbers m_c for each letter. This word counting interpretation is called closed string word counting since the loops can be thought as closed strings made from open strings which are the edges extending between nodes. The validity of this interpretation will be explained by using its equivalence to an open string word counting.

Appendix B.5 gives more examples of direct checks of this connection between closed string word counting and the building block function $F_0^{[n]}$.

From the derivation of the generating function of gauge invariants we know that

$$F_0^{[n]}(\{x_{ab}\}) = \frac{1}{\det(1_n - X_n)} = \sum_{\vec{p}} \prod_{a=1}^n \left(\sum_{b=1}^n p_{ab} \right)! \left(\prod_{b=1}^n \frac{x_{ab}^{p_{ab}}}{p_{ab}!} \right) \delta \left(\sum_{b=1}^n (p_{ab} - p_{ba}) \right) \quad (2.4.10)$$

This gives another way to see that the coefficients in the expansion are positive, and in fact integers. Consider the coefficient of $\prod_{a,b} x_{ab}^{p_{ab}}$, which is

$$\prod_a \frac{(\sum_{b=1}^n p_{ab})!}{\prod_{b=1}^n p_{ab}!} \delta \left(\sum_{b=1}^n (p_{ab} - p_{ba}) \right) \quad (2.4.11)$$

This leads directly to the open string word counting. Consider letters \hat{x}_{ab} corresponding to each directed edge, going from a to b in the complete n -node quiver. We will call these *open string bits*. Then consider words which are sequences of these letters. These words will be called open string words. We impose the commutation condition

$$\hat{x}_{ab}\hat{x}_{a'b'} = \hat{x}_{a'b'}\hat{x}_{ab} \quad (2.4.12)$$

for $a \neq a'$. So sequences which differ by such a swap are counted as the same word. Thus, string bits which have different starting points do not commute. Two different string bits with the same starting point do not commute. For each starting point a the factor

$$\frac{(\sum_{b=1}^n p_{ab})!}{\prod_{b=1}^n p_{ab}!} \quad (2.4.13)$$

counts the number of sequences containing p_{ab} copies of \hat{x}_{ab} . Defining

$$p_a = \sum_b p_{ab} = \sum_b p_{ba} \quad (2.4.14)$$

an open string word will take the form

$$w_o = \hat{x}_{1a_1} \hat{x}_{1a_2} \cdots \hat{x}_{1a_{p_1}} \quad \hat{x}_{2a_{p_1+1}} \hat{x}_{2a_{p_1+2}} \cdots \hat{x}_{2a_{p_1+p_2}} \quad \cdots \quad \hat{x}_{na_{p_1+\cdots+p_{n-1}+1}} \cdots \hat{x}_{na_{p_1+\cdots+p_n}} \quad (2.4.15)$$

The open string bits with different starting points commute, so we have used that commutativity to place all the ones starting at 1 to the far left, the ones starting from 2 next, and so on. The integers $a_1, \cdots, a_{\sum_i p_i}$ will contain p_1 copies of 1, p_2 copies of 2 etc. This condition says that the sequence of open string bits that appear in the expansion of $F_0^{[n]}$ contains as many bits with starting point i as with end points as i . We will refer to this as charge conserving open string words. So we have shown that the $F_0^{[n]}$ counts charge-conserving open string words. Remarkably, Cartier and Foata proved that charge-conserving open string words are in 1-1 correspondence with closed string words! This is theorem 3.5 in Cartier-Foata [64].

We refer the reader to [64] for the formal proof. Here we explain, with examples, the meaning of this equivalence between the counting of charge-conserving open string words (COSW) and closed string words (CSW). Given an a CSW, it is easy to write down a corresponding COSW. Take for example

$$\hat{y}_{11} \hat{y}_{12} \hat{y}_{11} \hat{y}_{22} \hat{y}_{123} = \hat{y}_{11} \hat{y}_{12} \hat{y}_{22} \hat{y}_{11} \hat{y}_{123} \quad (2.4.16)$$

Write these closed-string letters in terms of open string bits:

$$\hat{y}_{11} = \hat{x}_{11}, \quad \hat{y}_{22} = \hat{x}_{22}, \quad \hat{y}_{12} = \hat{x}_{12} \hat{x}_{21}, \quad \hat{y}_{123} = \hat{x}_{12} \hat{x}_{23} \hat{x}_{31} \quad (2.4.17)$$

The word of interest becomes

$$\hat{x}_{11} \hat{x}_{12} \hat{x}_{21} \hat{x}_{11} \hat{x}_{22} \hat{x}_{12} \hat{x}_{23} \hat{x}_{31} = \hat{x}_{11} \hat{x}_{12} \hat{x}_{11} \hat{x}_{12} \quad \hat{x}_{21} \hat{x}_{22} \hat{x}_{23} \quad \hat{x}_{31} \quad (2.4.18)$$

We have used the commutativity to arrange as in (2.4.15). A CSW determines in this way a unique COSW.

The reverse is also true. A COSW determines a unique CSW. The general proof is non-trivial [64]. We just illustrate with some examples here. Consider some COSW with specified numbers of starting (and end-) points of particular types, say three starting and ending at 1, two at 2 and three at 3. These words are of the form

$$\hat{x}_{1,\tau(1)} \hat{x}_{1,\tau(1)} \hat{x}_{1,\tau(1)} \quad \hat{x}_{2,\tau(2)} \hat{x}_{2,\tau(2)} \quad \hat{x}_{3,\tau(3)} \hat{x}_{3,\tau(3)} \hat{x}_{3,\tau(3)} \quad (2.4.19)$$

Here τ is a permutation in S_8 , which should be thought of as moving the integers $\{1, 2, 3\}$ from their initial positions $(1, 1, 1, 2, 2, 3, 3, 3)$ to a new position. When τ is the identity we have the COSW

$$\hat{x}_{11} \hat{x}_{11} \hat{x}_{11} \quad \hat{x}_{22} \hat{x}_{22} \quad \hat{x}_{33} \hat{x}_{33} \hat{x}_{33} = \hat{y}_{11} \hat{y}_{11} \hat{y}_{11} \quad \hat{y}_{22} \hat{y}_{22} \quad \hat{y}_{33} \hat{y}_{33} \hat{y}_{33} \quad (2.4.20)$$

Suppose now $\tau = (1, 2, 3, 4, 5, 6, 7, 8)$, a cyclic permutation. The COSW is

$$\hat{x}_{13}\hat{x}_{11}\hat{x}_{11} \quad \hat{x}_{21}\hat{x}_{22} \quad \hat{x}_{32}\hat{x}_{33}\hat{x}_{33} \quad (2.4.21)$$

If we map this to closed string words, this will involve two copies of \hat{y}_{11} , two copies of \hat{y}_{33} , and $\hat{y}_{132} = \hat{x}_{13}\hat{x}_{32}\hat{x}_{21}$. The unique CSW is

$$\hat{y}_{132} \quad \hat{y}_{11}\hat{y}_{11} \quad \hat{y}_{22} \quad \hat{y}_{33}\hat{y}_{33} \quad (2.4.22)$$

In arriving at this, we did a re-arrangement which moves the \hat{x}_{32} across the \hat{x}_{22} . This is allowed, since the open string bits commute when they have different starting point. i.e. different first index. The reader is encouraged to play with different choices of τ . It is easy to see that permutations τ in S_8 are a somewhat redundant way to parametrize the COSW. In fact it is a coset of S_8 by $S_3 \times S_2 \times S_3$ that parametrizes the COSW. For any choice of τ , there is always a CSW, i.e a list of \hat{y}_c for different cycles, arranged in a specific order (modulo the commutation relations (2.4.9)), which agrees with the COSW after re-arrangements allowed by the commutation (2.4.12). This is guaranteed by theorem 3.5 of [64].

We have focused on the combinatoric interpretation of $F_0^{[n]}(\{x_{ab}\})$, in terms of the complete quiver graph. This basic building block generates the counting of gauge invariants at large N for any quiver, after taking an infinite product with the substitutions in (2.1.1). If we are interested in a quiver where there is no edge going from a to b , these substitutions involve setting $x_{ab} \rightarrow 0$ for that pair of nodes. It is instructive to consider the quantity

$$\mathcal{F}_0^{[n]}(\{x_{ab;\alpha}\}) = F_0^{[n]}(\{x_{ab} \rightarrow \sum_{\alpha} x_{ab,\alpha}\}) \quad (2.4.23)$$

which is not an infinite product, but knows about the connectivity of any chosen quiver graph, with general multiplicities (possibly zero) between any specified start and end-node. This quantity has an interpretation in terms of word counting of open string words, as it follows immediately from (2.4.10):

$$\mathcal{F}_0^{[n]}(\{x_{ab,\alpha}\}) = \sum_{\vec{p}} \prod_{a=1}^n \left(\sum_{b=1}^n \sum_{\alpha=1}^{M_{ab}} p_{ab,\alpha} \right)! \left(\prod_{b=1}^n \prod_{\alpha=1}^{M_{ab}} \frac{x_{ab,\alpha}^{p_{ab,\alpha}}}{p_{ab,\alpha}!} \right) \delta \left(\sum_{b=1}^n \sum_{\alpha=1}^{M_{ab}} (p_{ab,\alpha} - p_{ba,\alpha}) \right) \quad (2.4.24)$$

We again have the basic rule that different open string letters corresponding to string bits with the same starting point do not commute. Again by invoking the Cartier-Foata theorem we see that, for any quiver, it is possible to map the open word counting problem to a closed word counting problem, in which string letters corresponding to simple loops which share a node do not commute.

The building block $F_0^{[n]}(\{x_{ab}\})$ gives the counting of gauge invariants at large N , by means of a simple combinatoric operation involving an infinite product and elementary substitutions. One of our motivations for developing a combinatorial interpretation for $F_0^{[n]}(\{x_{ab}\})$, is that it highlights an interesting analogy with a deformation of the counting problems considered here.

We have focused on the counting of all holomorphic invariants made from chiral fields in an $\mathcal{N} = 1$ theory. In many of the $\mathcal{N} = 1$ theories of interest in AdS/CFT, the general holomorphic invariants form the chiral ring in the limit of zero superpotential, but beyond that, one wants to impose super-potential relations. In these cases, the counting of chiral gauge invariant operators leads to the N -fold symmetric product of the ring of functions on non-compact Calabi-Yau spaces [77]. In the large N limit, the plethystic exponential gives the counting in terms of the counting at $N = 1$. The $N = 1$ counting is a simple building block of the large N counting. It has a physical interpretation as the ring of functions on the CY and the plethystic exponential has an interpretation in terms of the bosonic statistics of many identical branes.

The procedure of taking an infinite product and making substitutions, that we have developed for the $N \rightarrow \infty$ counting at zero superpotential, can be viewed as an analog of the plethystic exponential. In this analogy the function $F_0^{[n]}(\{x_{ab}\})$ corresponds to the $U(1)$ counting, which is the same as counting holomorphic functions on a CY. The counting problems we have solved also correspond to some large N geometries: namely the spaces of multiple matrices, subject to gauge invariance constraints. There is no symmetric product structure in this geometry, but there is nevertheless a simple analog of the plethystic exponential. There is no physical interpretation of $F_0^{[n]}(\{x_{ab}\})$ as a gauge theory partition function, but there is nevertheless an interpretation in terms of string word counting partially commuting string letters. A deeper understanding and interpretation of these analogies will undoubtedly be fascinating.

2.5 The flavoured case: from contour integrals to a determinant expression

We now turn to the full picture, that is we allow for quarks and antiquarks. Take then eq. (2.2.28):

$$F^{[n]}(\{x_{ab}\}, \{t_a\}, \{\bar{t}_a\}) = \left(\prod_a \oint_{\mathcal{C}_a} \frac{dz_a}{2\pi i} \right) \prod_a I_a(x_{ab}, t_a, \bar{t}_a) \quad (2.5.1)$$

where

$$I_a(\vec{z}; \vec{x}_a, t_a, \bar{t}_a) = \frac{\exp(z_a t_a)}{z_a - \left(\bar{t}_a + \sum_{b=1}^n z_b x_{b,a} \right)} \quad (2.5.2)$$

Again we have to compute residues. First of all note that the numerator of (2.5.2) is regular in z_a , so that the only poles may come from its denominator. We can simplify the next steps by using a trick: let us rename $\bar{t}_a \equiv x_{0,a}$ and multiply it by a dummy variable, z_0 . Pictorially, this would consist of taking all the open (fundamental matter) edges in the quiver and joining them to a fictitious node, that we call ‘0 node’. For consistency, let us also rename $t_a \equiv x_{a,0}$. Using

this notation we can rewrite eq. (2.5.2) as

$$I_a(\vec{z}; \vec{x}_a, t_a, \bar{t}_a) = \frac{\exp(z_a x_{a,0})}{z_a - \left(z_0 x_{0,a} + \sum_{b=1}^n z_b x_{b,a} \right)} = \frac{\exp(z_a x_{a,0})}{z_a - \left(\sum_{b=0}^n z_b x_{b,a} \right)} \quad (2.5.3)$$

where it is understood that z_0 will be set to 1 after the z_i ($1 \leq i \leq n$) integrals have been done. This means that the intermediate expressions arising from successive integrations will take the same form as in the unflavoured case of Section 2.3. In particular the pole prescription still holds unaltered.

With this formalism, eq. (2.3.12) becomes

$$z_j^{*[r]} = z_j^*(z_{r+1}, \dots, z_n, z_0; \vec{x}) = \sum_{\substack{i>r \\ \cup \{i=0\}}} z_i \hat{a}_{i,j}^{[r]}, \quad (2.5.4)$$

and correspondingly eq. (2.3.19) gets modified as

$$\begin{aligned} \left(1 - \left(x_{r+1,r+1} + \sum_{i=1}^r \hat{a}_{r+1,i}^{[r]} x_{i,r+1} \right) \right) z_{r+1} &= \\ &= \sum_{\substack{j>r+1 \\ \cup \{j=0\}}} z_j \left(x_{j,r+1} + \sum_{i=1}^r \hat{a}_{j,i}^{[r]} x_{i,r+1} \right) \end{aligned} \quad (2.5.5)$$

We can then proceed in the exact same fashion as in section 2.3. The only manifestly different piece in the integrand are the numerators of (2.5.3). To highlight the similarity to the unflavoured case, we write

$$\tilde{I}_a(\vec{z}; \vec{x}_a) = \frac{1}{z_a - \left(x_{0,a} + \sum_{b=1}^n z_b x_{b,a} \right)} \equiv \frac{1}{z_a - \sum_{b=0}^n z_b x_{b,a}} \quad (2.5.6)$$

such that

$$I_a(\vec{z}; \vec{x}_a, t_a, \bar{t}_a) = \frac{\exp(z_a t_a)}{z_a - \left(\bar{t}_a + \sum_{b=1}^n z_b x_{b,a} \right)} \equiv \exp(z_a x_{a,0}) \tilde{I}_a(\vec{z}; \vec{x}_a) \quad (2.5.7)$$

For the flavoured case the equation corresponding to (2.3.15) would then be

$$\begin{aligned} F^{[n]} &= \prod_{j=1}^r H_j(\vec{x}) \left(\prod_{a>r} \oint_{\mathcal{C}_a} \frac{dz_a}{2\pi i} \right) \left(\prod_{k=1}^r \exp(z_k^{*[r]} x_{k,0}) \right) \\ &\quad \times \prod_{a>r} \tilde{I}_a(z_1^{*[r]}, z_2^{*[r]}, \dots, z_r^{*[r]}, z_{r+1}, z_{r+2}, \dots, z_n; \vec{x}_a) \exp(z_a x_{a,0}) \end{aligned} \quad (2.5.8)$$

where in exact analogy with (2.3.22)

$$H_j(\vec{x}) = \left(1 - \left(x_{j,j} + \sum_{i=1}^{j-1} \hat{a}_{j,i}^{[j-1]} x_{i,j} \right) \right)^{-1} \quad (2.5.9)$$

Again, we see that the only addition in comparison to the unflavoured case is the product over the exponential functions. After the n integrations have been done, using the definition in eq. (2.5.4), we have

$$z_k^{*[n]} = z_k^*(z_0; \vec{x}_k) = \sum_{\substack{i>n \\ \cup \{i=0\}}} z_i \hat{a}_{i,k}^{[n]} \equiv z_0 \hat{a}_{0,k}^{[n]} \quad (2.5.10)$$

At this point we set $z_0 = 1$. Eq. (2.5.10) becomes

$$z_k^{*[n]} = \hat{a}_{0,k}^{[n]}, \quad (2.5.11)$$

so that

$$\prod_{k=1}^n \exp\left(z_k^{*[n]} x_{k,0}\right) = \prod_{k=1}^n \exp\left(\hat{a}_{0,k}^{[n]} x_{k,0}\right) \quad (2.5.12)$$

We can then say that F is the product

$$F^{[n]} = \prod_{j=1}^n H_j(\vec{x}) \exp\left(z_j^{*[n]} x_{j,0}\right) = \prod_{j=1}^n \left(\frac{\exp\left(\hat{a}_{0,j}^{[n]} x_{j,0}\right)}{1 - x_{j,j} - \sum_{i=1}^{j-1} \hat{a}_{j,i}^{[j-1]} x_{i,j}} \right) \quad (2.5.13)$$

where $x_{p,0} = t_p$ and $x_{0,p} = \bar{t}_p$. As expected, by setting all the fundamental matter field chemical potentials to zero we return to the unflavoured case.

In Appendix B.6 we show that the numerator of this formula has the form

$$\exp\left(\sum_{j=1}^n \hat{a}_{0,j}^{[n]} t_j\right) = \exp\left(\sum_{p,q=1}^n t_p \bar{t}_q \frac{(-1)^{p+q} M_{p,q}}{\det(1_n - X_n)}\right) \quad (2.5.14)$$

where $M_{p,q}$ is the (p, q) minor² of the matrix $(1_n - X_n)$. We can then write

$$F^{[n]} = \frac{1}{\det(1_n - X_n)} \exp\left(\sum_{p,q=1}^n t_p \bar{t}_q \frac{(-1)^{p+q} M_{p,q}}{\det(1_n - X_n)}\right) \quad (2.5.15)$$

²We recall that the (p, q) minor $M_{p,q}$ of a square matrix A is defined as the determinant of the matrix obtained from removing the p -th row and q -th column from A .

A second expression for the same quantity is also given in Appendix B.6, and it reads

$$F^{[n]} = F_0^{[n]} \exp \left(t_p \bar{t}_q \partial^{p,q} \log F_0^{[n]} \right) \quad (2.5.16)$$

where we used Einstein summation on p, q , and $\partial^{p,q} = \frac{\partial}{\partial x_{pq}}$.

Note that, as in the unflavoured case, we can write $F^{[n]}$ as a determinant of a suitable matrix, which encodes all the information of the quiver under study. Since

$$\frac{(-1)^{p+q} M_{p,q}}{\det(1_n - X_n)} = (1_n - X_n)^{-1} \Big|_{q,p} \quad (2.5.17)$$

if we introduce the $n \times n$ matrices χ_n and Λ_n , defined by

$$\chi_n|_{p,q} = (1_n - X_n)^{-1} \Big|_{p,q}, \quad \Lambda_n|_{p,q} = t_p \bar{t}_q \quad (2.5.18)$$

then we can write

$$F^{[n]}(\{x_{ab}\}, \{t_a\}, \{\bar{t}_a\}) = \det \chi_n \exp [\text{Tr} (\chi_n \Lambda_n)] \quad (2.5.19)$$

Finally, the last equation can be put in the determinant form

$$F^{[n]}(\{x_{ab}\}, \{t_a\}, \{\bar{t}_a\}) = \det (\chi_n \exp [\chi_n \Lambda_n]) \quad (2.5.20)$$

The generating function \mathcal{Z} is obtained from F using eq. (2.2.27). However, from e.g. eq. (2.5.20) we see that t_a, \bar{t}_b always appear pairwise, so that we can rewrite (2.2.27) in the more symmetric form already anticipated in eq. (2.1.8), that is

$$\begin{aligned} & \mathcal{Z}(\{x_{ab,\alpha}\}, \{\mathcal{T}_{a,\beta}\}, \{\bar{\mathcal{T}}_{a,\gamma}\}) \\ &= \prod_i F^{[n]} \left(\left\{ x_{ab} \rightarrow \sum_{\alpha} x_{ab,\alpha}^i \right\}, \left\{ t_a \rightarrow \sum_{\beta} \frac{\text{Tr}(\mathcal{T}_{a,\beta}^i)}{\sqrt{i}} \right\}, \left\{ \bar{t}_a \rightarrow \sum_{\gamma} \frac{\text{Tr}(\bar{\mathcal{T}}_{a,\gamma}^i)}{\sqrt{i}} \right\} \right) \end{aligned} \quad (2.5.21)$$

This is the final expression for our large N generating function.

2.6 A few examples

We will now present some simple applications of our counting formulae, for the large N limit.

2.6.1 One node quiver

Rewriting the chemical potentials of the fields as $x_{11} \rightarrow x$, $t_1 \rightarrow t$, $\bar{t}_1 \rightarrow \bar{t}$, we have

$$\chi_1 = \frac{1}{1-x}, \quad \Lambda_1 = t\bar{t}, \quad (2.6.1)$$

so that

$$F^{[1]} = \det(\chi_1 \exp[\chi_1 \Lambda_1]) = \det(\chi_1) \exp[\text{Tr}(\chi_1 \Lambda_1)] = \frac{e^{\frac{t\bar{t}}{1-x}}}{1-x} \quad (2.6.2)$$

The large N generating function is then

$$\mathcal{Z}(\{x_\alpha\}, \{\mathcal{T}_\beta\}, \{\bar{\mathcal{T}}_\gamma\}) = \prod_i \frac{\exp\left(\frac{\sum_{\beta,\gamma} \text{Tr}(\mathcal{T}_\beta^i) \text{Tr}(\bar{\mathcal{T}}_\gamma^i)}{i(1 - \sum_\alpha x_\alpha^i)}\right)}{1 - \sum_\alpha x_\alpha^i} \quad (2.6.3)$$

For the $d = 4$, $\mathcal{N} = 4$ SYM theory with quiver shown in Figure 12

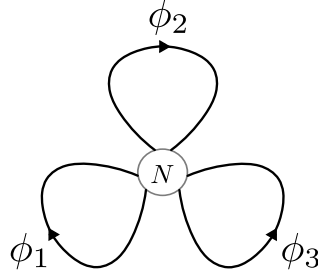

Figure 12: $d = 4$, $\mathcal{N} = 4$ SYM quiver

the \mathcal{Z} function is

$$\mathcal{Z}_{SYM}(x_1, x_2, x_3) = \prod_i \frac{1}{1 - x_1^i - x_2^i - x_3^i} \quad (2.6.4)$$

For the SQCD model, described by the quiver in figure 13

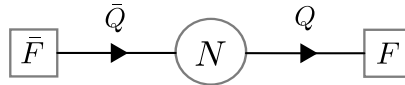

Figure 13: $d = 4$ $\mathcal{N} = 1$ SQCD quiver

the generating function is instead

$$\mathcal{Z}_{SQCD}(\mathcal{T}, \bar{\mathcal{T}}) = \prod_i \exp\left\{\frac{1}{i} \text{Tr}(\mathcal{T}^i) \text{Tr}(\bar{\mathcal{T}}^i)\right\} = \prod_{j=1}^F \prod_{k=1}^{\bar{F}} (1 - t_j \bar{t}_k)^{-1}, \quad (2.6.5)$$

where we used

$$\mathcal{T} = \text{diag}(t_1, t_2, \dots, t_F), \quad \bar{\mathcal{T}} = \text{diag}(\bar{t}_1, \bar{t}_2, \dots, \bar{t}_{\bar{F}}) \quad (2.6.6)$$

Note that if in the last example we do not distinguish the $U(1) \subset U(F)$ charges of the quarks

and the $U(1) \subset U(\bar{F})$ charges of the antiquarks, that is we set $\mathcal{T} = t 1_F$ and $\bar{\mathcal{T}} = \bar{t} 1_{\bar{F}}$, we get

$$\mathcal{Z}_{SQCD}(t 1_F, \bar{t} 1_{\bar{F}}) = (1 - t\bar{t})^{-F\bar{F}} \quad (2.6.7)$$

which was already derived in [78], using different counting methods.

An interesting gauge theory can be obtained by adding a flavour symmetry to $\mathcal{N} = 4$ SYM [49, 50]. This operation breaks half of the supersymmetries leaving an $\mathcal{N} = 2$ theory, which in turn we can describe with the $\mathcal{N} = 1$ quiver [79] in figure 14.

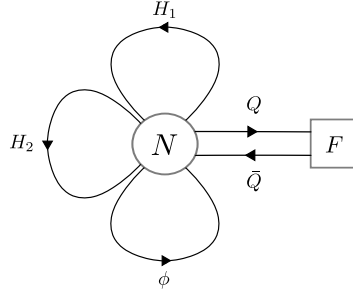

Figure 14: $\mathcal{N} = 2$ SQCD with and adjoint hypermultiplet.

The $\mathcal{N} = 2$ theory has a vector multiplet \mathcal{V} (1 complex scalar ϕ) and an hypermultiplet \mathcal{H} (two complex scalars H_1, H_2) both in the adjoint of $U(N)$. A second hypermultiplet \mathcal{Q} is in the bifundamental $U(N) \times U(F)$, where $U(F)$ is a global (non-dynamical) flavour symmetry (two complex scalars Q, \bar{Q} , transforming in opposite way under the symmetry group). The large N generating function for this quiver, that we denote by $\mathcal{Z}_{\mathcal{N}=2}(x_1, x_2, x_3, \mathcal{T}, \bar{\mathcal{T}})$, is given by

$$\mathcal{Z}_{\mathcal{N}=2}(x_1, x_2, x_3, \mathcal{T}, \bar{\mathcal{T}}) = \prod_i \frac{\exp \left[\frac{\text{Tr}(\mathcal{T}^i) \text{Tr}(\bar{\mathcal{T}}^i)}{i(1 - x_1^i - x_2^i - x_3^i)} \right]}{1 - x_1^i - x_2^i - x_3^i} \quad (2.6.8)$$

The first terms in the expansion of the unrefined $\mathcal{Z}_{\mathcal{N}=2}(x_1, x_2, x_3, t 1_F, \bar{t} 1_F)$ read

$$\begin{aligned} \mathcal{Z}_{\mathcal{N}=2}(x_1, x_2, x_3, t 1_F, \bar{t} 1_F) &= 1 + x_1 + x_2 + x_3 + F^2 t\bar{t} + 2x_1 x_2 + 2x_1 x_3 + 2x_2 x_3 + 2F^2 t\bar{t} x_1 \\ &+ 2F^2 t\bar{t} x_2 + 2F^2 t\bar{t} x_3 + 6x_1 x_2 x_3 + \frac{F^2}{2} (1 + F^2) t^2 \bar{t}^2 \\ &+ 6F^2 t\bar{t} x_1 x_2 + 6F^2 t\bar{t} x_1 x_3 + 6F^2 t\bar{t} x_2 x_3 + \frac{F^2}{2} (1 + 3F^2) t^2 \bar{t}^2 x_1 + \dots \end{aligned} \quad (2.6.9)$$

Let us now check explicitly the validity of our generating function for some of these coefficients, in the large N limit. Let us start off by considering just one quark/antiquark pair and one adjoint scalar, say H_1 . The Gauge Invariant Operators (GIOs) we can build out of these fields

are

$$(\phi)(\bar{Q}Q)_i^k, \quad (\bar{Q}\phi Q)_i^k \quad (2.6.10)$$

where upper and lower indices belong to the fundamental and antifundamental of $U(F)$ and $U(\bar{F})$ respectively, and round brackets denote $U(N)$ indices contraction. The total number of GIOs for this given configuration is $2F^2$. We see that this value is the same one of the coefficient $t\bar{t}x_1$, so that we have a first test of the validity of (2.6.9). Consider now the situation in which we only have two pairs of quarks/antiquarks. The only GIOs we can form are of the form

$$(\bar{Q}Q)_{l_1}^{k_1} (\bar{Q}Q)_{l_2}^{k_2} \quad (2.6.11)$$

using the same convention of the example above for the flavour and gauge indices. This is just a product of two matrix elements of the same F dimensional matrix $(\bar{Q}Q)$. The total number of inequivalent GIOs is then $\frac{1}{2}F^2(1+F^2)$: once again this is the same coefficient of the term $(t\bar{t})^2$ in (2.6.9). As a last example, suppose added to the last configuration a single field ϕ . The GIOs we can form would then be

$$(\phi)(\bar{Q}Q)_{l_1}^{k_1} (\bar{Q}Q)_{l_2}^{k_2}, \quad (\bar{Q}\phi Q)_{l_1}^{k_1} (\bar{Q}Q)_{l_2}^{k_2} \quad (2.6.12)$$

The one on the left consists brings a total of $\frac{F^2}{2}(1+F^2)$ GIOs, while the one on the right adds another F^2 GIOs to the final quantity, which then reads

$$\frac{F^2}{2}(1+F^2) + F^2 = \frac{F^2}{2}(1+3F^2) \quad (2.6.13)$$

In agreement with the coefficient of $(t\bar{t})^2x_1$ in (2.6.9).

2.6.2 Two node quiver

We now present some two-node quiver examples. From the definitions in (2.1.5) we can immediately write

$$\chi_2 = (1_2 - X_2)^{-1} = \frac{1}{\det(1_2 - X_2)} \begin{pmatrix} 1 - x_{22} & x_{12} \\ x_{21} & 1 - x_{11} \end{pmatrix}, \quad (2.6.14)$$

and

$$\Lambda_2 = \begin{pmatrix} t_1\bar{t}_1 & t_1\bar{t}_2 \\ t_2\bar{t}_1 & t_2\bar{t}_2 \end{pmatrix}; \quad (2.6.15)$$

The first terms in the power expansion of $\mathcal{Z}_{\text{Conifold}}^{\text{Flavoured}}(a_1, a_2, b_1, b_2, q_1, q_2, \bar{q}_1, \bar{q}_2)$ in the large N limit then read

$$\begin{aligned}
 \mathcal{Z}_{\text{Conifold}}^{\text{Flavoured}} = & 1 + a_1 b_1 + 2a_1^2 b_1^2 + 2a_1^2 b_1 b_2 + 2a_2 a_1 b_1^2 + a_1 b_2 + 2a_2^2 b_1^2 + a_2 b_1 + a_2 b_2 + \text{Tr}_{F_1}(q_1) \text{Tr}_{\bar{F}_1}(\bar{q}_1) \\
 & + 2a_1 b_1 \text{Tr}_{F_1}(q_1) \text{Tr}_{\bar{F}_1}(\bar{q}_1) + 2a_2 b_1 \text{Tr}_{F_1}(q_1) \text{Tr}_{\bar{F}_1}(\bar{q}_1) + 4a_1^2 b_1^2 \text{Tr}_{F_1}(q_1) \text{Tr}_{\bar{F}_1}(\bar{q}_1) \\
 & + 6a_1 a_2 b_1^2 \text{Tr}_{F_1}(q_1) \text{Tr}_{\bar{F}_1}(\bar{q}_1) + a_1 \text{Tr}_{F_1}(q_1) \text{Tr}_{\bar{F}_2}(\bar{q}_2) + 12a_1 a_2 b_1 b_2 \text{Tr}_{F_1}(q_1) \text{Tr}_{\bar{F}_1}(\bar{q}_1) + \dots
 \end{aligned}
 \tag{2.6.18}$$

2.6.3 Three node quiver: dP_0

The del Pezzo dP_0 gauge theory (obtained from $D3$ branes on $\mathbb{C}_3/\mathbb{Z}_3$ orbifold singularities [80]) contains nine bifundamental fields charged under the $U(N_1) \times U(N_2) \times U(N_3)$ gauge group as represented in figure 16, in which we also added flavour symmetry.

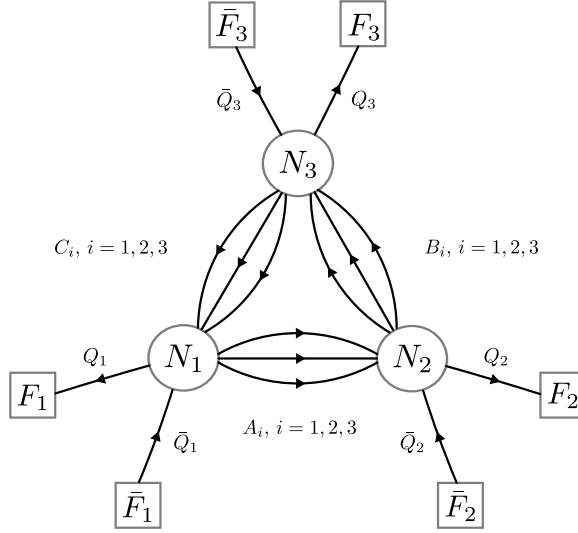

Figure 16: Flavoured dP_0 gauge theory.

We refer to this theory as the flavoured dP_0 theory. Using the convention for the chemical potentials of the fields

$$\begin{aligned}
 x_{12,1} &\rightarrow a_1, & x_{12,2} &\rightarrow a_2, & x_{12,3} &\rightarrow a_3, & \mathcal{T}_{1,1} &\rightarrow q_1, & \bar{\mathcal{T}}_{1,1} &\rightarrow \bar{q}_1, \\
 x_{23,1} &\rightarrow b_1, & x_{23,2} &\rightarrow b_2, & x_{23,3} &\rightarrow b_3, & \mathcal{T}_{2,1} &\rightarrow q_2, & \bar{\mathcal{T}}_{2,1} &\rightarrow \bar{q}_2, \\
 x_{31,1} &\rightarrow c_1, & x_{31,2} &\rightarrow c_2, & x_{31,3} &\rightarrow c_3, & \mathcal{T}_{3,1} &\rightarrow q_3, & \bar{\mathcal{T}}_{3,1} &\rightarrow \bar{q}_3
 \end{aligned}
 \tag{2.6.19}$$

we can write the generating function for the flavoured dP_0 theory in the large N limit as:

$$\begin{aligned}
 \mathcal{Z}_{dP_0 \text{ Flav.}} &= \prod_i \frac{1}{1 - \sum_{j,k,l=1}^3 (a_j b_k c_l)^i} \\
 &\times \exp \left(\frac{\text{Tr}_{F_1}(q_1^i) \left(\text{Tr}_{\bar{F}_1}(\bar{q}_1^i) + \text{Tr}_{\bar{F}_3}(\bar{q}_3^i) \sum_{p=1}^3 a_p^i + \text{Tr}_{\bar{F}_2}(\bar{q}_2^i) \sum_{p,q=1}^3 c_p^i a_q^i \right)}{i \left(1 - \sum_{j,k,l=1}^3 (a_j b_k c_l)^i \right)} \right. \\
 &\quad + \frac{\text{Tr}_{F_2}(q_2^i) \left(\text{Tr}_{\bar{F}_2}(\bar{q}_2^i) + \text{Tr}_{\bar{F}_1}(\bar{q}_1^i) \sum_{p=1}^3 b_p^i + \text{Tr}_{\bar{F}_3}(\bar{q}_3^i) \sum_{p,q=1}^3 b_p^i a_q^i \right)}{i \left(1 - \sum_{j,k,l=1}^3 (a_j b_k c_l)^i \right)} \\
 &\quad \left. + \frac{\text{Tr}_{F_3}(q_3^i) \left(\text{Tr}_{\bar{F}_3}(\bar{q}_3^i) + \text{Tr}_{\bar{F}_2}(\bar{q}_2^i) \sum_{p=1}^3 c_p^i + \text{Tr}_{\bar{F}_1}(\bar{q}_1^i) \sum_{p,q=1}^3 b_p^i c_q^i \right)}{i \left(1 - \sum_{j,k,l=1}^3 (a_j b_k c_l)^i \right)} \right) \quad (2.6.20)
 \end{aligned}$$

Chapter 3

Correlators in the Quiver Restricted Polynomials Basis

In this chapter we will be focusing on the construction of a basis for the Hilbert space of holomorphic matrix invariants for the class of quiver gauge theories described in section 1.4. This basis is obtained in terms of *Quiver Restricted Schur Polynomials* $\mathcal{O}_{\mathcal{Q}}(\mathbf{L})$, that we define in Section 3.2. These are a generalisation of the restricted Schur operators introduced in [22–24, 30, 81]. In [26], the non-flavoured versions of these objects were called Generalised Restricted Schur operators, constructed in terms of quiver characters $\chi_{\mathcal{Q}}(\mathbf{L})$ where \mathbf{L} is a collection of representation theory labels. In this flavoured case, we will find generalisations of these quiver characters, where the representation labels will include flavour states organised according to irreducible representations of the flavour groups. The advantages of using this approach is twofold. On the one hand, the Quiver Restricted Schur polynomials are orthogonal in the free field metric, as we will show, even for flavoured gauge theories. This leads to the simple expression for the two point function in eq. (3.3.1):

$$\langle \mathcal{O}_{\mathcal{Q}}(\mathbf{L}) \mathcal{O}_{\mathcal{Q}}^{\dagger}(\mathbf{L}') \rangle = \delta_{\mathbf{L}, \mathbf{L}'} c_{\vec{n}} \prod_a f_{N_a}(R_a) \quad (3.0.1)$$

In this equation $f_{N_a}(R_a)$ represents the product of weights of the $U(N_a)$ representation R_a , where a runs over the gauge nodes of the quiver. $c_{\vec{n}}$ is a constant depending on the matter content of the matrix invariant $\mathcal{O}_{\mathcal{Q}}(\mathbf{L})$, given in (3.2.27). On the other hand, the Quiver Restricted Schur polynomial formalism offers a simple way to capture the finite N constraints of matrix invariants. This can be seen directly from (3.0.1): each $f_{N_a}(R_a)$ vanishes if the length of the first column of the R_a Young diagram exceeds N_a .

In subsection 3.4 we give an N -exact expression for the three point function of matrix invariants in the free limit. This computation is performed using the Quiver Restricted Schur polynomial basis. Specifically, we will derive the $G_{\mathbf{L}^{(1)}, \mathbf{L}^{(2)}, \mathbf{L}^{(3)}}$ coefficients in

$$\langle \mathcal{O}_{\mathcal{Q}}(\mathbf{L}^{(1)}) \mathcal{O}_{\mathcal{Q}}(\mathbf{L}^{(2)}) \mathcal{O}_{\mathcal{Q}}^{\dagger}(\mathbf{L}^{(3)}) \rangle = c_{\vec{n}^{(3)}} G_{\mathbf{L}^{(1)}, \mathbf{L}^{(2)}, \mathbf{L}^{(3)}} \prod_a f_{N_a}(R_a^{(3)}) \quad (3.0.2)$$

The analytical expression for $G_{\mathbf{L}^{(1)}, \mathbf{L}^{(2)}, \mathbf{L}^{(3)}}$ looks rather complicated, but it can be easily understood in terms of diagrams. Although the identities we need appear somewhat complex, they all have a simple diagrammatic interpretation. Diagrammatics therefore play a central role in this chapter: all the quantities we define and the calculational steps we perform can be visualised in terms of networks involving *symmetric group branching coefficients* and *Clebsch-Gordan coefficients*. Both these quantities are defined in Section 3.2. The quantity $G_{\mathbf{L}^{(1)}, \mathbf{L}^{(2)}, \mathbf{L}^{(3)}}$ is actually found to be a product over the gauge groups: for each gauge group there is a network of symmetric group branching coefficients and a single Clebsch-Gordan coefficient.

The organisation of the chapter is as follows. In Section 3.1 we describe a permutation based approach to label matrix invariants of the flavoured gauge theories under study. A matrix invariant will be constructed using a set of permutations (schematically σ) associated with gauge nodes of the quiver, and by a collection of fundamental and antifundamental states (schematically s, \bar{s}) of the flavour group, associated with external flavour nodes. In this section we highlight how the simplicity of apparently complex formulae can be understood via diagrammatic techniques. We describe equivalence relations, generated by the action of permutations associated with edges of the quiver (schematically η), acting on the gauge node permutations and flavour states. Equivalent data label the same matrix invariant. The equivalence is explained further and illustrated in Appendix A.1. The equivalences η can be viewed as “permutation gauge symmetries”, while the (σ, s, \bar{s}) can be viewed as “matter fields” for these permutation gauge symmetries.

In Section 3.2 we give a basis of the matrix invariants using representation theory data, \mathbf{L} . This can be viewed as a *dual basis* where representation theory is used to perform a Fourier transformation on the equivalence classes of the permutation description. We refer to these gauge invariants, polynomial in the bi-fundamental and fundamental matter fields, as Quiver Restricted Schur polynomials. In this section we introduce the two main mathematical ingredients needed in this formalism. These are the symmetric group branching coefficients and the Clebsch-Gordan coefficients. Their definition will be accompanied by a corresponding diagram.

In Section 3.3 we derive the results for the free field two and three point function of gauge invariants. In subsection 3.3.1 we show that the two point function which couples holomorphic and anti-holomorphic matrix invariants is diagonal in the basis of Quiver Restricted Schur polynomials. In subsection 3.4 we give a diagrammatic description of the structure constants of the ring of Holomorphic Gauge Invariant Operators (GIOs). In particular, we present a step by step procedure to obtain such a diagram for the example of an $\mathcal{N} = 2$ SQCD, starting from its split-node diagram. Using these formulae, we identify four selection rules, all expressed in terms of symmetric group representation theory data. The analytical calculations are reported in Appendix A.3, and rely on the Quiver Restricted Schur polynomial technology introduced in the previous section.

Finally, in Section 3.5, we give some examples of the matrix invariants we can build using our method, for the case of an $\mathcal{N} = 2$ SQCD.

3.1 Gauge invariant operators and permutations

In this section we will present a systematic approach to list and label every holomorphic matrix invariant in quiver gauge theories of the type discussed above. We also allow for a flavour symmetry of the type discussed in Section 1.4. The operators we consider are polynomial in the Φ , Q and \bar{Q} type fields that are invariant under gauge transformations. Therefore, all colour indices are contracted to produce traces and products of traces of these fields. For example

$$(\Phi_{ab}\Phi_{bc}\cdots\Phi_{ca}), \quad (\Phi_{ab}\Phi_{ba})(\Phi_{cc}), \quad (\bar{Q}_a^k Q_{la}), \quad (\bar{Q}_a^k \Phi_{ab} \Phi_{bc} \cdots \Phi_{cd} Q_{dl}) \quad (3.1.1)$$

and products thereof are suitable matrix invariants. In these examples round brackets denote contraction of gauge indices (*i.e.* traces), while k, l are flavour indices. The last two examples belong to the class of GIOs that in the literature has been called ‘generalised mesons’ (see *e.g.* [82]). In order to label these matrix polynomials, the first ingredient we need to specify is the number of fundamental fields that they contain. Let $n_{ab,\alpha}$ be the number of copies of $\Phi_{ab,\alpha}$ fields that are used to build the GIO. Similarly, let $n_{a,\beta}$ ($\bar{n}_{a,\gamma}$) be the number of copies of $Q_{a,\beta}$ quarks ($\bar{Q}_{a,\gamma}$ antiquarks) used in the GIO. In other words, the polynomial is characterised by degrees \vec{n} given by

$$\vec{n} = \cup_a \{ \cup_{b,\alpha} n_{ab,\alpha}; \cup_{\beta} n_{a,\beta}; \cup_{\gamma} \bar{n}_{a,\gamma} \} \quad (3.1.2)$$

For fixed degrees there is a large number of gauge invariant polynomials, differing in how the gauge indices are contracted. To guarantee gauge invariance we have to impose that the GIO does not have any free gauge indices. This condition implies the constraint on \vec{n}

$$\begin{cases} n_a = \sum_{b,\alpha} n_{ab,\alpha} + \sum_{\beta} n_{a,\beta} = \sum_{b,\alpha} n_{ba,\alpha} + \sum_{\gamma} \bar{n}_{a,\gamma} & \forall a \\ n_\alpha = \sum_a \sum_{\beta} n_{a,\beta} = \sum_a \sum_{\gamma} \bar{n}_{a,\gamma} \end{cases} \quad (3.1.3)$$

We now introduce a second vector-like quantity, \vec{s} . It will store the information about the states of the quarks and antiquarks in the matrix invariant. To do so, let us first define the states

$$|\mathbf{s}_{a,\beta}\rangle \in V_{F_{a,\beta}}^{\otimes n_{a,\beta}}, \quad \langle \bar{\mathbf{s}}_{a,\gamma} | \in \bar{V}_{\bar{F}_{a,\gamma}}^{\otimes \bar{n}_{a,\gamma}} \quad (3.1.4)$$

Here $V_{F_{a,\beta}}$ is the fundamental representation of $U(F_{a,\beta})$ and $\bar{V}_{\bar{F}_{a,\gamma}}$ is the antifundamental representation of $U(\bar{F}_{a,\gamma})$. Therefore, $|\mathbf{s}_{a,\beta}\rangle$ is the tensor product of all the $U(F_{a,\beta})$ fundamental representation states of the $n_{a,\beta}$ quarks $Q_{a,\beta}$. Similarly, $\langle \bar{\mathbf{s}}_{a,\gamma} |$ is the tensor product of all the $U(\bar{F}_{a,\gamma})$ antifundamental representation states of the $\bar{n}_{a,\gamma}$ quarks $\bar{Q}_{a,\gamma}$. We define the vector \vec{s} as the collection of these state labels:

$$\vec{s} = \cup_a \{ \cup_{\beta} \mathbf{s}_{a,\beta}; \cup_{\gamma} \bar{\mathbf{s}}_{a,\gamma} \} \quad (3.1.5)$$

In the framework that we are going to introduce in this section, the building blocks of any

matrix invariant are the tensor products of the fundamental fields $\Phi_{ab,\alpha}^{\otimes n_{ab,\alpha}}$, $Q_{a,\beta}^{\otimes n_{a,\beta}}$ and $\bar{Q}_{a,\gamma}^{\otimes \bar{n}_{a,\gamma}}$. Let us then introduce the states

$$\begin{aligned} |I_{ab,\alpha}\rangle &= |i_1, \dots, i_{n_{ab,\alpha}}\rangle \in V_{N_a}^{\otimes n_{ab,\alpha}}, & |I_{a,\beta}\rangle &= |i_1, \dots, i_{n_{a,\beta}}\rangle \in V_{N_a}^{\otimes n_{a,\beta}} \\ |J_{ab,\alpha}\rangle &= |j_1, \dots, j_{n_{ab,\alpha}}\rangle \in V_{N_a}^{\otimes n_{ab,\alpha}}, & |\bar{J}_{a,\gamma}\rangle &= |\bar{j}_1, \dots, \bar{j}_{\bar{n}_{a,\gamma}}\rangle \in V_{N_a}^{\otimes \bar{n}_{a,\gamma}} \end{aligned}$$

Using these definitions, together with eq. (3.1.4), we can write the matrix elements of every $\Phi_{ab,\alpha}^{\otimes n_{ab,\alpha}}$ tensor product as

$$\left(\Phi_{ab,\alpha}^{\otimes n_{ab,\alpha}}\right)_{J_{ab,\alpha}}^{I_{ab,\alpha}} = \langle I_{ab,\alpha} | \Phi_{ab,\alpha}^{\otimes n_{ab,\alpha}} | J_{ab,\alpha} \rangle \quad (3.1.6)$$

and similarly for $Q_{a,\beta}^{\otimes n_{a,\beta}}$ and $\bar{Q}_{a,\gamma}^{\otimes \bar{n}_{a,\gamma}}$:

$$\left(Q_{a,\beta}^{\otimes n_{a,\beta}}\right)_{\mathbf{s}_{a,\beta}}^{I_{a,\beta}} = \langle I_{a,\beta} | Q_{a,\beta}^{\otimes n_{a,\beta}} | \mathbf{s}_{a,\beta} \rangle, \quad \left(\bar{Q}_{a,\gamma}^{\otimes \bar{n}_{a,\gamma}}\right)_{\bar{J}_{a,\gamma}}^{\bar{\mathbf{s}}_{a,\gamma}} = \langle \bar{\mathbf{s}}_{a,\gamma} | \bar{Q}_{a,\gamma}^{\otimes \bar{n}_{a,\gamma}} | \bar{J}_{a,\gamma} \rangle \quad (3.1.7)$$

We will now present the first of the many diagrammatic techniques that we will use throughout this chapter. We draw the matrix components of fundamental fields $(\Phi_{ab,\alpha})_j^i$, $(Q_{a,\beta})_s^i$ and $(\bar{Q}_{a,\gamma})_j^{\bar{s}}$ as in Fig. 17.

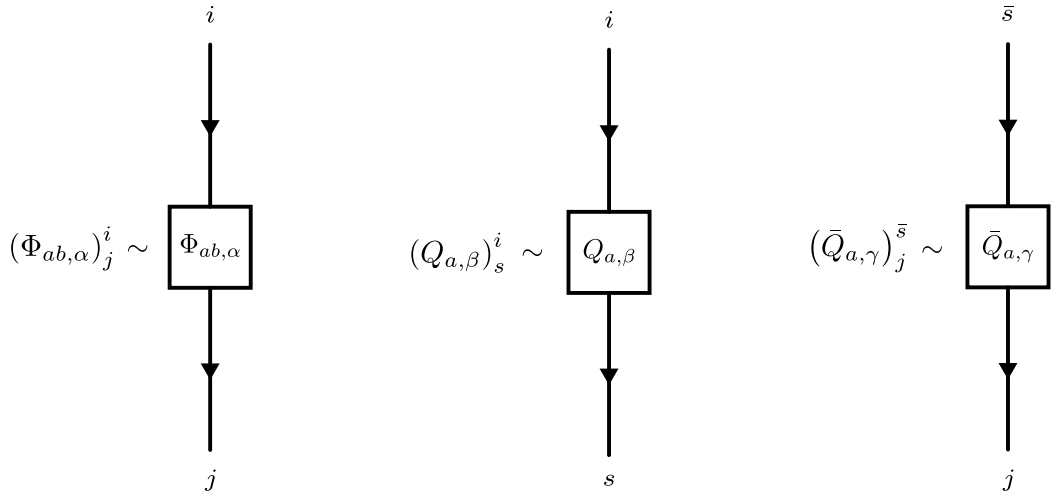

Figure 17: Diagrammatic description of the matrix elements of the fundamental fields Φ , Q and \bar{Q} .

This diagrammatic notation is then naturally extended to the tensor products $\left(\Phi_{ab,\alpha}^{\otimes n_{ab,\alpha}}\right)_{J_{ab,\alpha}}^{I_{ab,\alpha}}$, $\left(Q_{a,\beta}^{\otimes n_{a,\beta}}\right)_{\mathbf{s}_{a,\beta}}^{I_{a,\beta}}$ and $\left(\bar{Q}_{a,\gamma}^{\otimes \bar{n}_{a,\gamma}}\right)_{\bar{J}_{a,\gamma}}^{\bar{\mathbf{s}}_{a,\gamma}}$, defined in eqs. 3.1.6 and 3.1.7, as in Fig. 18.

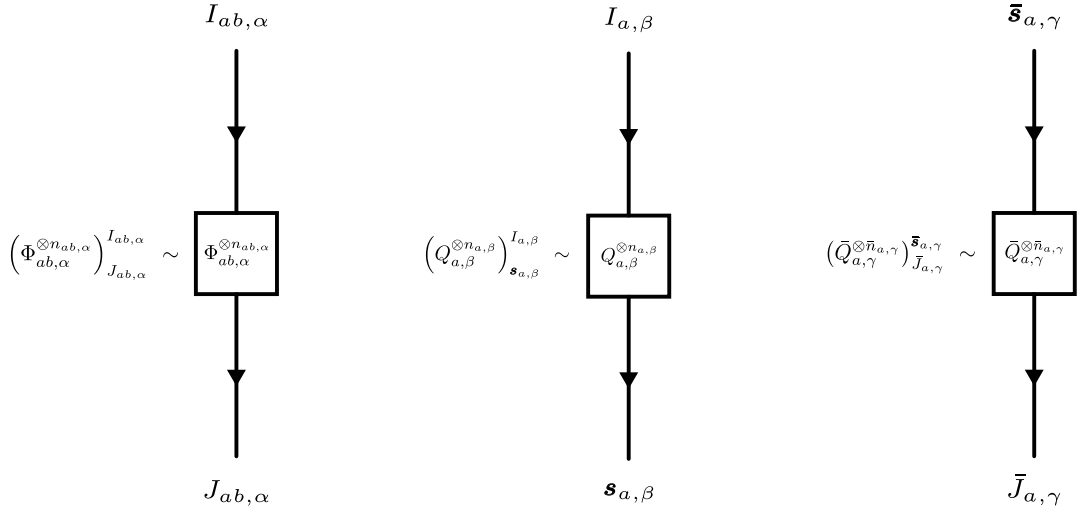

Figure 18: Diagrammatic description of the matrix elements of the tensor products of the fundamental fields Φ , Q and \bar{Q} .

Permutations act on a tensor product of states by rearranging the order in which the states are tensored together. For example, given a permutation $\sigma \in S_k$ and a tensor product of k states $|i_a\rangle$ ($1 \leq a \leq k$) belonging to some vector space V , we have

$$\sigma|i_1, i_2, \dots, i_k\rangle = |i_{\sigma(1)}, i_{\sigma(2)}, \dots, i_{\sigma(k)}\rangle \quad (3.1.8)$$

Therefore, there is a natural permutation action on the states (3.1.4) and (3.1.6).

The gauge invariant polynomial is constructed by contracting the upper n_a indices of all the fields incident at the node a with their lower n_a indices. We describe these gauge invariants as follows. First we choose an ordering for all the fields with an upper $U(N_a)$ index. Then we fix a set of labelled upper indices: this means that we have picked an embedding of subsets into the set $[n_a] \equiv \{1, \dots, n_a\}$, *i.e.*

$$[n_{a1, \alpha=1}] \sqcup [n_{a1, \alpha=2}] \sqcup \dots \sqcup [n_{a2, \alpha=1}] \sqcup [n_{a2, \alpha=2}] \sqcup \dots \sqcup [n_{a, \beta=1}] \sqcup [n_{a, \beta=2}] \sqcup \dots \rightarrow [n_a] \quad (3.1.9)$$

which gives a set-partition of $[n_a]$. Similarly, there is an embedding into $[n_a]$ corresponding to the ordering of the lower $U(N_a)$ indices, namely

$$[n_{1a, \alpha=1}] \sqcup [n_{1a, \alpha=2}] \sqcup \dots \sqcup [n_{2a, \alpha=1}] \sqcup [n_{2a, \alpha=2}] \sqcup \dots \sqcup [\bar{n}_{a, \gamma=1}] \sqcup [\bar{n}_{a, \gamma=2}] \sqcup \dots \rightarrow [n_a] \quad (3.1.10)$$

Now we contract the upper indices of these fields with their lower indices, *after* a permutation $\sigma_a \in S_{n_a}$ of their labels. We will therefore be considering permutations $\sigma_a \in S_{n_a}$, where $n_a = \sum_{b, \alpha} n_{ab, \alpha} + \sum_{\beta} n_{a, \beta} = \sum_{b, \alpha} n_{ba, \alpha} + \sum_{\gamma} n_{a, \gamma}$. Along the lines of eqs. (3.1.6) and (3.1.7) we can define the matrix elements of σ_a as

$$(\sigma_a)_{\times_{b, \alpha} J_{ab, \alpha} \times_{\beta} I_{a, \beta}}^{\times_{b, \alpha} J_{ba, \alpha} \times_{\gamma} \bar{J}_{a, \gamma}} = \left(\otimes_{b, \alpha} \langle J_{ba, \alpha} | \otimes_{\gamma} \langle \bar{J}_{a, \gamma} | \right) \sigma_a \left(\otimes_{b, \alpha} | I_{ab, \alpha} \rangle \otimes_{\beta} | I_{a, \beta} \rangle \right) \quad (3.1.11)$$

where the product symbols appearing in the upper and lower indices of σ_a are ordered as in (3.1.9) and (3.1.10). We depict these matrix elements as in Fig. 19.

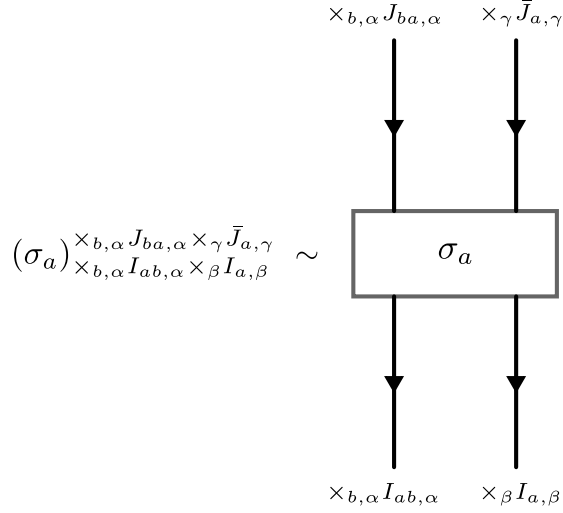

Figure 19: Diagrammatic description of the matrix elements of the permutation σ .

Following the approach of [26], we can write any GIO $\mathcal{O}_{\mathcal{Q}}$ of a quiver gauge theory \mathcal{Q} with flavour symmetry as

$$\begin{aligned} \mathcal{O}_{\mathcal{Q}}(\vec{n}; \vec{s}; \vec{\sigma}) &= \prod_a \left[\prod_{b,\alpha} \left(\Phi_{ab,\alpha}^{\otimes n_{ab,\alpha}} \right)_{J_{ab,\alpha}}^{I_{ab,\alpha}} \right] \otimes \left[\prod_{\beta} \left(Q_{a,\beta}^{\otimes n_{a,\beta}} \right)_{\mathbf{s}_{a,\beta}}^{I_{a,\beta}} \right] \otimes \left[\prod_{\gamma} \left(\bar{Q}_{a,\gamma}^{\otimes \bar{n}_{a,\gamma}} \right)_{\bar{J}_{a,\gamma}}^{\bar{\mathbf{s}}_{a,\gamma}} \right] \\ &\quad \times \prod_a (\sigma_a)^{\times_{b,\alpha} J_{ba,\alpha} \times_{\gamma} \bar{J}_{a,\gamma} / \times_{b,\alpha} I_{ab,\alpha} \times_{\beta} I_{a,\beta}} \end{aligned} \quad (3.1.12)$$

Here $\vec{\sigma} = \cup_a \{\sigma_a\}$ is a collection of permutations $\sigma_a \in S_{n_a}$, where $n_a = \sum_{b,\alpha} n_{ab,\alpha} + \sum_{\beta} n_{a,\beta}$. The purpose of $\vec{\sigma}$ is to contract all the gauge indices of the Φ , Q and \bar{Q} fields to make a proper GIO. This formula looks rather complicated. However, it can be nicely interpreted in a diagrammatic way. We will now give an example of such a diagrammatic approach. Consider an $\mathcal{N} = 2$ SQCD theory. The $\mathcal{N} = 1$ quiver for this model is illustrated in Fig. 20.

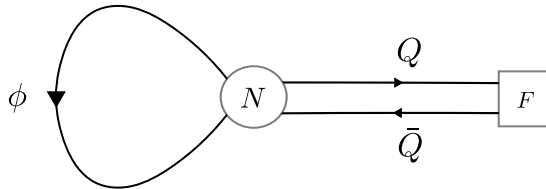

Figure 20: The $\mathcal{N} = 1$ quiver for an $\mathcal{N} = 2$ SQCD model.

We labelled the fields of this quiver by ϕ , Q and \bar{Q} , simplifying the notation given in table 1. Consider now the GIO $(\bar{Q}\phi Q)_{\bar{s}_1}^{s_1} (\bar{Q}Q)_{s_2}^{\bar{s}_2}$. Here s_1 , s_2 and \bar{s}_1 , \bar{s}_2 are states of the fundamental and

antifundamental representation of $SU(F)$ respectively, and the round brackets denotes $U(N)$ indices contraction. Figure 21 shows the diagrammatic interpretation of this GIO.

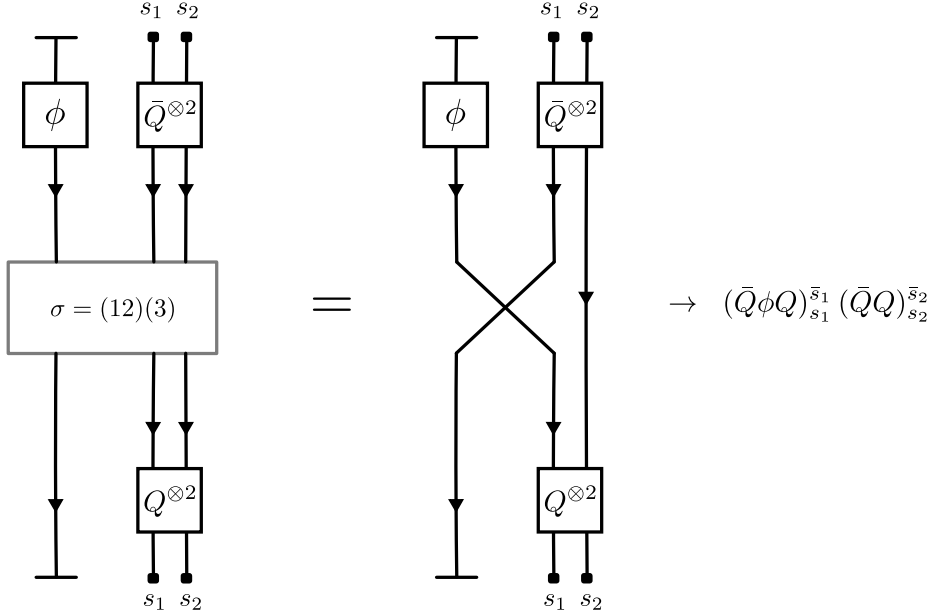

Figure 21: Diagrammatic description of the GIO $(\bar{Q}\phi Q)_{s_1}^{\bar{s}_1} (\bar{Q}Q)_{s_2}^{\bar{s}_2}$ in an $\mathcal{N} = 2$ SQCD. The horizontal bars are to be identified.

For fixed \vec{n} , the data $\vec{\sigma}, \vec{s}$ determines a gauge invariant. However changing $\vec{\sigma}, \vec{s}$ can produce the same invariant. This fact can be described in terms of an equivalence relation generated by the action of permutations, associated with edges of the quiver, on the data $\vec{\sigma}, \vec{s}$. This has been discussed for the case without flavour symmetry in [26] and we will extend the discussion to flavours here. Continuing the example of the $\mathcal{N} = 2$ SQCD introduced above, let us consider a matrix invariant built with n adjoint fields ϕ and n_q quarks and antiquarks Q and \bar{Q} . We label the tensor product of all the n_q quark states $|s_i\rangle \in V_{SU(F)}$ with the shorthand notation $|\mathbf{s}\rangle = \otimes_{i=1}^{n_q} |s_i\rangle$. Here $V_{SU(F)}$ is the fundamental representation of $SU(F)$. Similarly, $\langle \bar{\mathbf{s}}| = \otimes_{i=1}^{n_q} \langle \bar{s}_i|$ will be the tensor product of all the antiquarks states $\langle \bar{s}_i| \in \bar{V}_{SU(F)}$, where $\bar{V}_{SU(F)}$ is the antifundamental representation of $SU(F)$. In this model, a matrix invariant can be labelled by the triplet $(\sigma, \mathbf{s}, \bar{\mathbf{s}})$. The redundancy discussed above is captured by the identification

$$(\sigma, \mathbf{s}, \bar{\mathbf{s}}) \sim ((\eta \times \bar{\rho})\sigma(\eta^{-1} \times \rho^{-1}), \rho(\mathbf{s}), \bar{\rho}(\bar{\mathbf{s}})) \quad (3.1.13)$$

where $\eta \in S_n$, $\rho, \bar{\rho} \in S_{n_q}$ and $\rho(\mathbf{s}) = (s_{\rho(1)}, s_{\rho(2)}, \dots, s_{\rho(n_q)})$, $\bar{\rho}(\bar{\mathbf{s}}) = (\bar{s}_{\bar{\rho}(1)}, \bar{s}_{\bar{\rho}(2)}, \dots, \bar{s}_{\bar{\rho}(n_q)})$. The last two equations are to be interpreted as the action of ρ and $\bar{\rho}^{-1}$ on the states $|\mathbf{s}\rangle$ and $\langle \bar{\mathbf{s}}|$:

$$\rho|\mathbf{s}\rangle = |s_{\rho(1)}, s_{\rho(2)}, \dots, s_{\rho(n_q)}\rangle, \quad \langle \bar{\mathbf{s}}|\bar{\rho}^{-1} = \langle \bar{s}_{\bar{\rho}(1)}, \bar{s}_{\bar{\rho}(2)}, \dots, \bar{s}_{\bar{\rho}(n_q)}| \quad (3.1.14)$$

We refer to Appendix A.1 for a diagrammatic interpretation of this equivalence.

For the general case of a gauge theory with flavour symmetry, the degeneracy is described

by the identity

$$\mathcal{O}_{\mathcal{Q}}(\vec{n}; \vec{s}; \vec{\sigma}) = \mathcal{O}_{\mathcal{Q}}(\vec{n}; \vec{\rho}(\vec{s}); \text{Adj}_{\vec{\eta} \times \vec{\rho}}(\vec{\sigma})) \quad (3.1.15)$$

Here we introduced the permutations

$$\vec{\eta} = \cup_{a,b,\alpha} \{\eta_{ab,\alpha}\} , \quad \eta_{ab,\alpha} \in S_{n_{ab,\alpha}} \quad (3.1.16a)$$

$$\vec{\rho} = \cup_a \{\cup_{\beta} \rho_{a,\beta}; \cup_{\gamma} \bar{\rho}_{a,\gamma}\} , \quad \rho_{a,\beta} \in S_{n_{a,\beta}} , \quad \bar{\rho}_{a,\gamma} \in S_{\bar{n}_{a,\gamma}} \quad (3.1.16b)$$

and we defined

$$\text{Adj}_{\vec{\eta} \times \vec{\rho}}(\vec{\sigma}) = \cup_a \{(\times_{b,\alpha} \eta_{ba,\alpha} \times_{\gamma} \bar{\rho}_{a,\gamma}) \sigma_a (\times_{b,\alpha} \eta_{ab,\alpha}^{-1} \times_{\beta} \rho_{a,\beta}^{-1})\} , \quad (3.1.17)$$

$$\vec{\rho}(\vec{s}) = \cup_a \{\cup_{\beta} \rho_{a,\beta}(\mathbf{s}_{a,\beta}); \cup_{\gamma} \bar{\rho}_{a,\gamma}(\bar{\mathbf{s}}_{a,\gamma})\} \quad (3.1.18)$$

In Appendix A.1 we will derive the constraint (3.1.15). This is essentially a set of equivalences of the type (3.1.13), iterated over all the nodes and edges of the quiver. The permutations $\eta_{ab,\alpha}, \rho_{a,\beta}, \bar{\rho}_{a,\gamma}$ can be viewed as “permutation gauge symmetries”, associated with the edges of the quiver. The permutations $\vec{\sigma}$ and state labels \vec{s} can be viewed as “matter fields” for the permutation gauge symmetries, associated with the nodes of the quiver. It is very intriguing that, in terms of the original Lie group gauge symmetry, the round nodes were associated with gauge groups $U(N_a)$, while the edges were matter. In this world of permutations, these roles are reversed, with the edges being associated with gauge symmetries and the nodes with matter.

So far we have used a permutation basis approach to characterise the quiver matrix invariants. This has offered a nice diagrammatic interpretation, but on the other hand it is subject to the complicated constraint in eq. (3.1.15). In the following section we are going to introduce a Fourier Transformation (FT) from this permutation description to its dual space, which is described in terms of representation theory quantities. In other words, we are going to change the way we label the matrix invariants: instead of using permutation data, we are going to use representation theory data. The upshot of doing so is twofold. On one hand the new basis will not be subject to any equivalence relation such as the one in (3.1.15). On the other hand, as a consequence of the Schur-Weyl duality (see *e.g.* [68]), it offers a simple way to capture the finite N constraints of the GIOs. Schematically, using this FT we trade the set of labels $\{\vec{n}; \vec{s}; \vec{\sigma}\}$ of any GIO for the new set $\{R_a, r_{ab,\alpha}, r_{a,\beta}, S_{a,\beta}, \bar{r}_{a,\gamma}, \bar{S}_{a,\gamma}, \nu_a^+, \nu_a^-\}$, that we denote with the shorthand notation \mathbf{L} :

$$\text{FT} : \{\vec{n}; \vec{s}; \vec{\sigma}\} \rightarrow \mathbf{L} = \{R_a, r_{ab,\alpha}, r_{a,\beta}, S_{a,\beta}, \bar{r}_{a,\gamma}, \bar{S}_{a,\gamma}, \nu_a^+, \nu_a^-\} \quad (3.1.19)$$

Each R_a is a representation of the symmetric group S_{n_a} , where n_a has been defined in (3.1.3). $r_{ab,\alpha}, r_{a,\beta}, \bar{r}_{a,\gamma}$ are partitions of $n_{ab,\alpha}, n_{a,\beta}, \bar{n}_{a,\gamma}$ respectively. $S_{a,\beta}$ and $\bar{S}_{a,\gamma}$ are $U(F_{a,\beta})$ and $U(\bar{F}_{a,\gamma})$ states in the representation specified by the partitions $r_{a,\beta}$ and $\bar{r}_{a,\gamma}$ respectively. The

integers ν_a^\pm are symmetric group multiplicity labels, a pair for each node in the quiver. Their meaning will be explained in the next section. Graphically, at each node a of the quiver we change the description of any matrix invariant as in Fig. 22. The diagram on the right in this figure is also called a *split-node* [26].

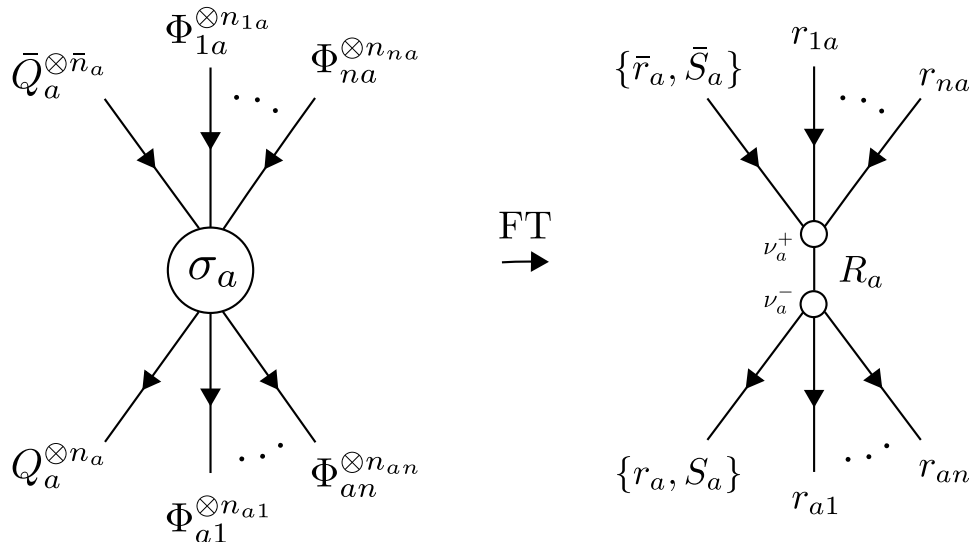

Figure 22: Pictorial representation of the Fourier transform discussed in the text. The multiplicity labels of the fields are not displayed.

We call the Fourier transformed operators *Quiver Restricted Schur polynomials*, or quiver Schurs for short. These are a generalisation of the Restricted Schur polynomials that first appeared in the literature in [22–24,30,81]. In section 3.3.1 we will show how the quiver Schurs form a basis for the Hilbert space of holomorphic operators.

3.2 The quiver restricted Schur polynomials

In this section we describe the FT introduced above. In other words, we will explicitly construct the map

$$\text{FT} : \mathcal{O}_{\mathcal{Q}}(\vec{n}; \vec{s}; \vec{\sigma}) \rightarrow \mathcal{O}_{\mathcal{Q}}(\mathbf{L}) \tag{3.2.1}$$

In order to do so, we need to introduce two main mathematical ingredients. These are the symmetric group branching coefficients and the Clebsch-Gordan coefficients. For each of these quantities we give both an analytic and a diagrammatic description: the latter will aid to make notationally heavy formulae easier to understand.

We begin by focusing on the symmetric group branching coefficients. Consider the symmetric

group restriction

$$\times_{i=1}^k S_{n_i} \rightarrow S_n, \quad \sum_{i=1}^k n_i = n \quad (3.2.2)$$

For each representation $V_R^{S_n}$ of S_n , this restriction induces the representation branching

$$V_R^{S_n} \simeq \bigoplus_{\substack{r_1 \vdash n_1 \\ r_2 \vdash n_2 \\ \dots \\ r_k \vdash n_k}} \left(\bigotimes_{i=1}^k V_{r_i}^{S_{n_i}} \right) \otimes V_{\vec{r}}^{\vec{r}}, \quad \vec{r} = (r_1, r_2, \dots, r_k) \quad (3.2.3)$$

$V_{\vec{r}}^{\vec{r}}$ is the *multiplicity* vector space, in case the representation $\otimes_i V_{r_i}$ appears more than once in the decomposition (3.2.3). The dimension of this space is $\dim(V_{\vec{r}}^{\vec{r}}) = g(\cup_{i=1}^k r_i; R)$, where $g(\cup_{i=1}^k r_i; R) = g(r_1, r_2, \dots, r_k; R)$ are Littlewood-Richardson coefficients [68].

In the following, the vectors belonging to any vector space V will be denoted using a bra-ket notation. The symbol $\langle \cdot | \cdot \rangle$ will indicate the inner product in V . Let then the set of vectors $\{|\otimes_{i=1}^k r_i, l_i, \nu\rangle\}$ be an orthonormal basis for $\bigoplus_{\vec{r}} \left(\bigotimes_{i=1}^k V_{r_i}^{S_{n_i}} \right) \otimes V_{\vec{r}}^{\vec{r}}$. Here l_i is a state in $V_{r_i}^{S_{n_i}}$ and $\nu = 1, \dots, g(\cup_{i=1}^k r_i; R)$ is a multiplicity label. We adopt the convention that $|\otimes_{i=1}^k r_i, l_i, \nu\rangle \equiv |\cup_i r_i, \cup_i l_i, \nu\rangle$. Similarly, let the set of vectors $\{|R, j\rangle, j = 1, \dots, \dim(V_R^{S_n})\}$ be an orthonormal basis for $V_R^{S_n}$. The branching coefficients $B_{j \rightarrow \cup_i l_i}^{R \rightarrow \cup_i r_i; \nu}$ are the matrix entries of the linear invertible operator B , mapping

$$B : V_R^{S_n} \longrightarrow \bigoplus_{\vec{r}} \left(\bigotimes_{i=1}^k V_{r_i}^{S_{n_i}} \right) \otimes V_{\vec{r}}^{\vec{r}} \quad (3.2.4)$$

so that

$$B_{j \rightarrow \cup_k l_k}^{R \rightarrow \cup_k r_k; \nu} |R, j\rangle = |\cup_i r_i, \cup_i l_i, \nu\rangle \quad (3.2.5)$$

The sum over repeated indices is understood. By acting with $\langle S, i |$ on the left of both sides of (3.2.5) we then have

$$B_{i \rightarrow \cup_k l_k}^{S \rightarrow \cup_k r_k; \nu} = \langle S, i | \cup_i r_i, \cup_i l_i, \nu \rangle \quad (3.2.6)$$

Since B is an automorphism that maps an orthonormal basis to an orthonormal basis, it follows that B is a unitary operator, $B^\dagger = B^{-1}$. We can then write

$$\sum_j B_{j \rightarrow \cup_i l_i}^{R \rightarrow \cup_i r_i; \nu} (B^\dagger)_{\cup_i q_i \rightarrow j}^{\cup_i s_i; \mu \rightarrow R} = \left(\prod_i \delta^{s_i, r_i} \delta_{q_i, l_i} \right) \delta^{\mu, \nu} \quad (3.2.7)$$

However, since all the irreducible representations of any symmetric group can be chosen to be real [83], there exists a convention in which the branching coefficients (3.2.6) are also real. Therefore $B^\dagger = B^T$, where B^T is the transpose of the map (3.2.5). Using this last fact we can

write the chain of equalities

$$\langle S, i | \cup_i r_i, \cup_i l_i, \nu \rangle = B_{i \rightarrow \cup_k l_k}^{S \rightarrow \cup_k r_k; \nu} = (B^T)_{\cup_k l_k \rightarrow i}^{\cup_k r_k; \nu \rightarrow S} = (B^{-1})_{\cup_k l_k \rightarrow i}^{\cup_k r_k; \nu \rightarrow S} = \langle \cup_i r_i, \cup_i l_i, \nu | S, i \rangle \quad (3.2.8)$$

We draw the branching coefficients (3.2.6) as in Fig. 23. The orientation of the arrows can be reversed because of the identities in (3.2.8).

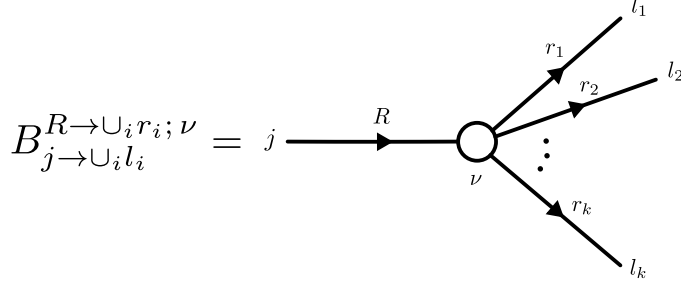

Figure 23: Pictorial description of the symmetric group branching coefficients.

Consider now taking k irreducible representations $V_{r_i}^{U(N)}$ of the unitary group $U(N)$, $i = 1, 2, \dots, k$. For each $V_{r_i}^{U(N)}$, r_i is a partition of some integer n_i . This partition is associated with a Young diagram which is used to label the representation. If we tensor together all the $V_{r_i}^{U(N)}$'s, we generally end up with a reducible representation, and we have the isomorphism (see *e.g.* [83])

$$\bigotimes_{i=1}^k V_{r_i}^{U(N)} \simeq \bigoplus_{\substack{R \vdash n \\ c_1(R) \leq N}} V_R^{U(N)} \otimes V_{\vec{r}}^{\vec{r}}, \quad n = \sum_{i=1}^k n_i, \quad (3.2.9)$$

Here R is a partition of $n = \sum_i n_i$. The direct sum on the RHS above is restricted to the Young diagrams R whose first column length $c_1(R)$ does not exceed the rank N of the gauge group. $V_{\vec{r}}^{\vec{r}}$, with $\vec{r} = (r_1, r_2, \dots, r_k)$, is the multiplicity vector space, satisfying $\dim(V_{\vec{r}}^{\vec{r}}) = g(\cup_{i=1}^k r_i; R)$. The $g(\cup_{i=1}^k r_i; R)$ coefficients that appear in this formula are the same Littlewood-Richardson coefficients that we used in the above description of the symmetric group branching coefficients. Now let the set of vectors $\{|r_i, K_j\rangle\}$ be an orthonormal basis for $V_{r_i}^{U(N)}$, for $i = 1, 2, \dots, k$. Here K_j is a state in $V_{r_i}^{U(N)}$. Also let $\{|R, M; \nu\rangle\}$ be an orthonormal basis for $\bigoplus_{R \vdash n} V_R^{U(N)} \otimes V_{\vec{r}}^{\vec{r}}$. Here M is a state in the $U(N)$ representation $V_R^{U(N)}$ and ν is a multiplicity index. The Clebsch-Gordan coefficients $C_{M \rightarrow \cup_i K_i}^{R; \nu \rightarrow \cup_i r_i}$ are the matrix entries of the linear invertible operator C , mapping

$$C : \bigotimes_{i=1}^k V_{r_i}^{U(N)} \longrightarrow \bigoplus_{R \vdash n} V_R^{U(N)} \otimes V_{\vec{r}}^{\vec{r}} \quad (3.2.10)$$

so that

$$C_{M \rightarrow \cup_i K_i}^{R; \nu \rightarrow \cup_i r_i} |\cup_i r_i, \cup_i K_i\rangle = |R, M; \nu\rangle \quad (3.2.11)$$

The sum over repeated indices is understood. By acting on the left of both sides of (3.2.11)

with $\langle \cup_i s_i, \cup_i P_i |$, where P_i are states of the $U(N)$ representations $V_{s_i}^{U(N)}$, we get

$$C_{M \rightarrow \cup_i P_i}^{R; \nu \rightarrow \cup_i s_i} = \langle \cup_i s_i, \cup_i P_i | R, M; \nu \rangle \quad (3.2.12)$$

From (3.2.11), we see that the automorphism C maps an orthonormal basis to an orthonormal basis. This makes C a unitary operator, $C^\dagger = C^{-1}$, and we can therefore write

$$\sum_{\vec{r}, \vec{K}} C_{M \rightarrow \cup_i K_i}^{R; \nu \rightarrow \cup_i r_i} (C^\dagger)_{\cup_i K_i \rightarrow P}^{\cup_i r_i \rightarrow S; \mu} = \delta^{S, R} \delta_{P, M} \delta^{\mu, \nu} \quad (3.2.13)$$

As with the branching coefficients, it is always possible to choose a consistent convention in which all the $U(N)$ Clebsch-Gordan coefficients (3.2.12) are real. If we choose to work with such a convention, C becomes an orthogonal operator: $C^T = C^{-1}$. We then have, in the same fashion of (3.2.8)

$$\langle \cup_i s_i, \cup_i P_i | R, M; \nu \rangle = C_{M \rightarrow \cup_i P_i}^{R; \nu \rightarrow \cup_i s_i} = (C^T)_{\cup_i P_i \rightarrow M}^{\cup_i s_i \rightarrow R; \nu} = (C^{-1})_{\cup_i P_i \rightarrow M}^{\cup_i s_i \rightarrow R; \nu} = \langle R, M; \nu | \cup_i s_i, \cup_i P_i \rangle \quad (3.2.14)$$

We draw the Clebsch-Gordan coefficients as in Fig. 24. Again, the orientation of the arrows can be reversed, due to (3.2.14).

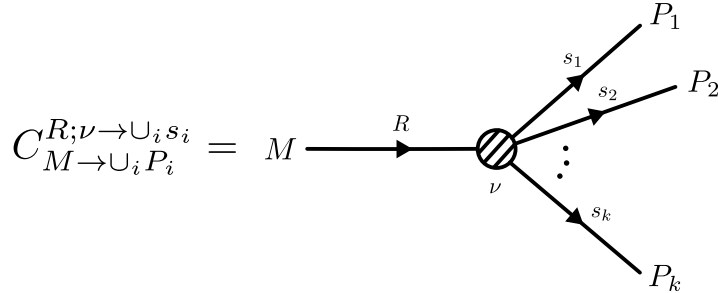

Figure 24: Pictorial representation of the $U(N)$ Clebsch-Gordan coefficient in eq. (3.2.12).

Consider now the particular case of (3.2.9) in which every representation $V_{r_i}^{U(N)}$ tensored on the LHS coincides with the $U(N)$ fundamental³ representation, that for simplicity we just call V for the remainder of this section. This configuration allows us to use the Schur-Weyl duality to write

$$\overbrace{V \otimes \dots \otimes V}^{k \text{ times}} = V^{\otimes k} \simeq \bigoplus_{\substack{R \vdash k \\ c_1(R) \leq N}} V_R^{U(N)} \otimes V_R^{S_k} \quad (3.2.15)$$

where $V_R^{U(N)}$ and $V_R^{S_k}$ are irreducible representations of $U(N)$ and S_k respectively. They correspond to the Young diagrams specified by the partition R of k . By comparing (3.2.15) with

³We can get similar results by replacing the fundamental with the antifundamental representation of $U(N)$. The quantities we define here get modified accordingly.

(3.2.9), we see that the representation $V_R^{S_k}$ has now taken the place of the generic multiplicity vector space $V_R^{\vec{r}}$. Since the Schur-Weyl decomposition will play a major role in this construction, we are now going to introduce a more compact notation for its Clebsch-Gordan coefficients. Let us consider the states

$$|\mathbf{s}\rangle = \otimes_{j=1}^k |s_j\rangle \in V^{\otimes k}, \quad |s_j\rangle \in V, \quad |R; M, i\rangle = |R, M\rangle \otimes |R, i\rangle \in V_R^{U(N)} \otimes V_R^{S_k} \quad (3.2.16)$$

where $\{|R, M\rangle, M = 1, \dots, \dim(V_R^{U(N)})\}$ and $\{|R, i\rangle, i = 1, \dots, \dim(V_R^{S_k})\}$ are orthonormal bases of $V_R^{U(N)}$ and $V_R^{S_k}$ respectively. The equations (3.2.11) and (3.2.14) imply

$$C_{\mathbf{s}}^{R, M, i} |\mathbf{s}\rangle = |R, M, i\rangle \quad (3.2.17)$$

and

$$C_{\mathbf{t}}^{R, M, i} = \langle \mathbf{t} | R, M, i \rangle = \langle R, M, i | \mathbf{t} \rangle = C_{R, M, i}^{\mathbf{t}} \quad (3.2.18)$$

respectively. We draw these quantities as in Fig. 25.

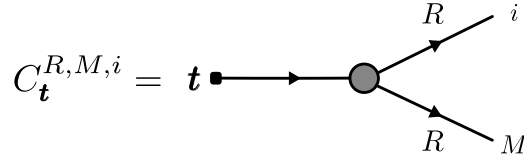

Figure 25: Pictorial representation of the $U(N)$ Clebsch-Gordan coefficients (3.2.18) for the Schur-Weyl duality (3.2.15).

3.2.1 The quiver characters

We now have all the tools necessary to introduce a key quantity, the *quiver characters* $\chi_{\mathcal{Q}}(\mathbf{L}, \vec{s}, \vec{\sigma})$. Here \mathbf{L} is the set of representation theory labels defined in (3.1.19). The quiver characters are the expansion coefficients of the FT (3.2.1):

$$\mathcal{O}_{\mathcal{Q}}(\mathbf{L}) = \sum_{\vec{s}} \sum_{\vec{\sigma}} \chi_{\mathcal{Q}}(\mathbf{L}, \vec{s}, \vec{\sigma}) \mathcal{O}_{\mathcal{Q}}(\vec{n}, \vec{s}, \vec{\sigma}) \quad (3.2.19)$$

We define them as

$$\begin{aligned} \chi_{\mathcal{Q}}(\mathbf{L}, \vec{s}, \vec{\sigma}) = & c_{\mathbf{L}} \sum_{\{\{l_{a,b}, \alpha\}\}, \{\{\bar{l}_{a,\gamma}\}\}} \prod_a \sum_{i_a, j_a} D_{i_a, j_a}^{R_a}(\sigma_a) B_{j_a \rightarrow \cup_{b,\alpha} l_{ab}, \alpha \cup_{\beta} l_{a,\beta}}^{R_a \rightarrow \cup_{b,\alpha} r_{ab}, \alpha \cup_{\beta} r_{a,\beta}; \nu_a^-} \prod_{\beta} C_{\mathbf{s}_{a,\beta}}^{r_{a,\beta}, S_{a,\beta}, l_{a,\beta}} \\ & \times B_{i_a \rightarrow \cup_{b,\alpha} l_{ba}, \alpha \cup_{\gamma} \bar{l}_{a,\gamma}}^{R_a \rightarrow \cup_{b,\alpha} r_{ba}, \alpha \cup_{\gamma} \bar{r}_{a,\gamma}; \nu_a^+} \prod_{\gamma} C_{\bar{r}_{a,\gamma}, \bar{S}_{a,\gamma}, \bar{l}_{a,\gamma}}^{\bar{s}_{a,\gamma}} \end{aligned} \quad (3.2.20)$$

where the coefficient $c_{\mathbf{L}}$ is the normalisation constant

$$c_{\mathbf{L}} = \prod_a \left(\frac{d(R_a)}{n_a!} \right)^{\frac{1}{2}} \left(\prod_{b,\alpha} \frac{1}{d(r_{ab,\alpha})} \right)^{\frac{1}{2}} \left(\prod_{\beta} \frac{1}{d(r_{a,\beta})} \right)^{\frac{1}{2}} \left(\prod_{\gamma} \frac{1}{d(\bar{r}_{a,\gamma})} \right)^{\frac{1}{2}} \quad (3.2.21)$$

Since we chose to work in the convention in which all symmetric group representations and Clebsch-Gordan coefficients are real, then the quiver characters are real quantities as well:

$$\chi_{\mathcal{Q}}(\mathbf{L}, \vec{s}, \vec{\sigma}) = \chi_{\mathcal{Q}}^*(\mathbf{L}, \vec{s}, \vec{\sigma}) \quad (3.2.22)$$

This convention will be convenient when we compute the 2-point functions of holomorphic and anti-holomorphic matrix invariants in section 3.3.1.

These quantities have a pictorial interpretation. We have already introduced a diagrammatic notation for the branching and Clebsch-Gordan coefficients B and C in Fig. 23 and in Fig. 25 respectively. The pictorial notation for the i, j matrix element of the permutation σ in the irreducible representation R , $D_{i,j}^R(\sigma)$, is displayed in Fig. 26. All the edges of these diagrams are to be contracted together as per instructions of formula (3.2.20).

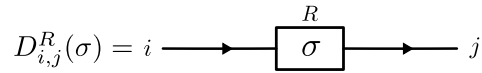

Figure 26: Pictorial description of the matrix element $D_{i,j}^R(\sigma)$ of the S_n symmetric group representation R .

Let us give an example of the diagrammatic of the quiver character of a well-known flavoured gauge theory. Consider the $\mathcal{N} = 1$ quiver for the flavoured conifold [52, 53, 75, 76] in Fig. 27.

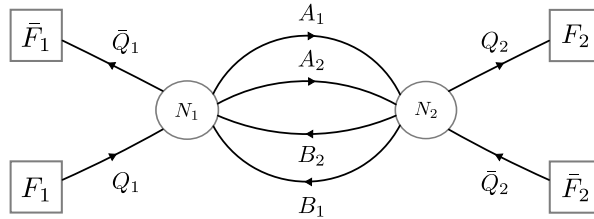

Figure 27: $\mathcal{N} = 1$ quiver for the flavoured conifold gauge theory.

The quiver character for this model is depicted in Fig. 28. This figure explicitly shows how all the symmetric group matrix elements, the branching coefficients and the Clebsch-Gordan coefficients are contracted together.

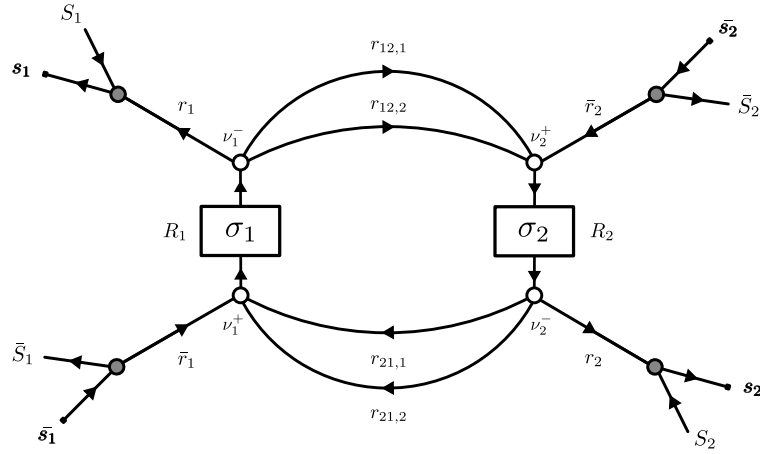

Figure 28: The quiver character diagram for the flavoured conifold gauge theory.

For completeness we also give a diagram for the the most generic quiver character $\chi_{\mathcal{Q}}(\mathbf{L}, \vec{s}, \vec{\sigma})$. This is done in Fig. 29. In this picture, we factored the quiver character into a product over the gauge nodes a of the quiver. All the internal edges (that is, the ones that are not connected to a Clebsch-Gordan coefficient) are contracted following the prescription of (3.2.20).

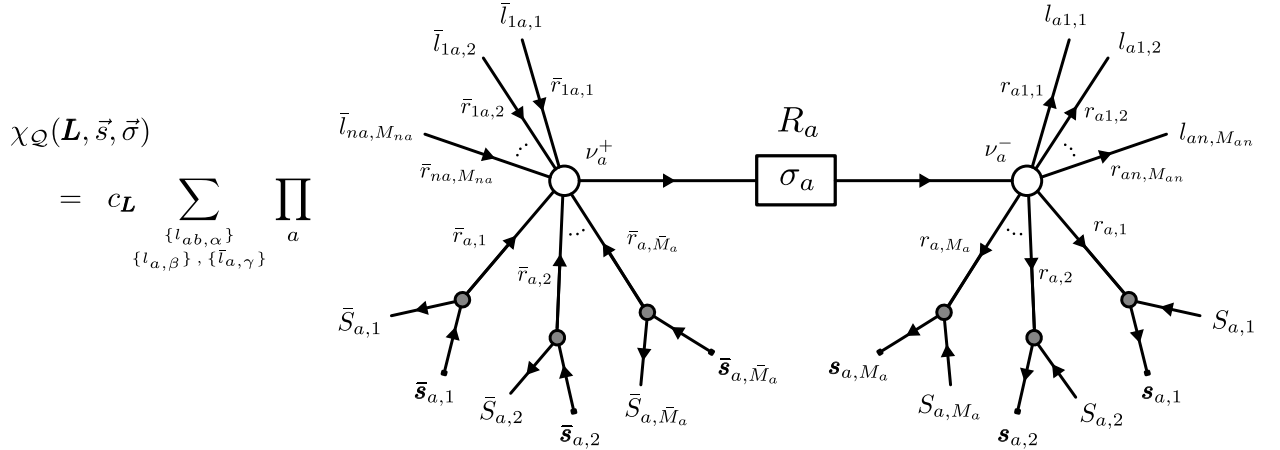

Figure 29: Pictorial description of the quiver characters $\chi_{\mathcal{Q}}(\mathbf{L}, \vec{s}, \vec{\sigma})$.

The quiver characters (3.2.20) satisfy the invariance relation

$$\chi_{\mathcal{Q}}(\mathbf{L}, \vec{s}, \vec{\sigma}) = \chi_{\mathcal{Q}}(\mathbf{L}, \vec{\rho}(\vec{s}), \text{Adj}_{\vec{\eta} \times \vec{\rho}}(\vec{\sigma})) \quad (3.2.23)$$

where $\text{Adj}_{\vec{\eta} \times \vec{\rho}}(\vec{\sigma})$ has been defined in (3.1.17):

$$\text{Adj}_{\vec{\eta} \times \vec{\rho}}(\vec{\sigma}) = \cup_a \{ (\times_{b,\alpha} \eta_{ba,\alpha} \times_{\gamma} \bar{\rho}_{a,\gamma}) \sigma_a (\times_{b,\alpha} \eta_{ab,\alpha}^{-1} \times_{\beta} \rho_{a,\beta}^{-1}) \} \quad (3.2.24)$$

They also satisfy the two orthogonality relations

$$\sum_{\vec{s}} \sum_{\vec{\sigma}} \chi_{\mathcal{Q}}(\mathbf{L}, \vec{s}, \vec{\sigma}) \chi_{\mathcal{Q}}(\tilde{\mathbf{L}}, \vec{s}, \vec{\sigma}) = \delta_{\mathbf{L}, \tilde{\mathbf{L}}} \quad (3.2.25)$$

and

$$\sum_{\mathbf{L}} \chi_{\mathcal{Q}}(\mathbf{L}, \vec{s}, \vec{\sigma}) \chi_{\mathcal{Q}}(\mathbf{L}, \vec{t}, \vec{\tau}) = \frac{1}{c_{\vec{n}}} \sum_{\vec{\eta} \times \vec{\rho}} \delta(\text{Adj}_{\vec{\eta} \times \vec{\rho}}(\vec{\sigma}) \vec{\tau}^{-1}) \delta_{\vec{\rho}(\vec{s}), \vec{t}} \quad (3.2.26)$$

where we introduced the normalisation constant

$$c_{\vec{n}} = \prod_a \left(\prod_{b, \alpha} n_{ab, \alpha}! \right) \left(\prod_{\beta} n_{a, \beta}! \right) \left(\prod_{\gamma} n_{a, \gamma}! \right) \quad (3.2.27)$$

It is worthwhile to note that this quantity can be interpreted as the order of the permutation gauge symmetry group. All of these equations are derived in Appendix A.2.

The set of operators (3.2.19) form the Quiver Restricted Schur polynomial basis. Using (3.2.23) we can immediately check that such operators are invariant under the constraint (3.1.15).

We have

$$\begin{aligned} \mathcal{O}_{\mathcal{Q}}(\mathbf{L}) &= \sum_{\vec{s}} \sum_{\vec{\sigma}} \chi_{\mathcal{Q}}(\mathbf{L}, \vec{s}, \vec{\sigma}) \mathcal{O}_{\mathcal{Q}}(\vec{n}, \vec{s}, \vec{\sigma}) \\ &= \sum_{\vec{s}} \sum_{\vec{\sigma}} \chi_{\mathcal{Q}}(\mathbf{L}, \vec{s}, \vec{\sigma}) \mathcal{O}_{\mathcal{Q}}(\vec{n}, \vec{\rho}(\vec{s}), \text{Adj}_{\vec{\eta} \times \vec{\rho}}(\vec{\sigma})) \\ &= \sum_{\vec{s}} \sum_{\vec{\sigma}} \chi_{\mathcal{Q}}(\mathbf{L}, \vec{\rho}(\vec{s}), \text{Adj}_{\vec{\eta} \times \vec{\rho}}(\vec{\sigma})) \mathcal{O}_{\mathcal{Q}}(\vec{n}, \vec{\rho}(\vec{s}), \text{Adj}_{\vec{\eta} \times \vec{\rho}}(\vec{\sigma})) \\ &= \sum_{\vec{s}} \sum_{\vec{\sigma}} \chi_{\mathcal{Q}}(\mathbf{L}, \vec{s}, \vec{\sigma}) \mathcal{O}_{\mathcal{Q}}(\vec{n}, \vec{s}, \vec{\sigma}) = \mathcal{O}_{\mathcal{Q}}(\mathbf{L}) \end{aligned} \quad (3.2.28)$$

were in the second line we used the constraint (3.1.15), in the third one the invariance of the quiver characters (3.2.23) and in the fourth one we relabelled the dummy variables of the double sum.

Finally, the FT (3.2.19) can be easily inverted. Starting from

$$\mathcal{O}_{\mathcal{Q}}(\mathbf{L}) = \sum_{\vec{t}} \sum_{\vec{\tau}} \chi_{\mathcal{Q}}(\mathbf{L}, \vec{t}, \vec{\tau}) \mathcal{O}_{\mathcal{Q}}(\vec{n}, \vec{t}, \vec{\tau}) \quad (3.2.29)$$

we multiply both sides by $\chi_{\mathcal{Q}}(\mathbf{L}, \vec{s}, \vec{\sigma})$ and we take the sum over the set of labels in \mathbf{L} to get

$$\sum_{\mathbf{L}} \chi_{\mathcal{Q}}(\mathbf{L}, \vec{s}, \vec{\sigma}) \mathcal{O}_{\mathcal{Q}}(\mathbf{L}) = \sum_{\vec{t}} \sum_{\vec{\tau}} \left(\sum_{\mathbf{L}} \chi_{\mathcal{Q}}(\mathbf{L}, \vec{s}, \vec{\sigma}) \chi_{\mathcal{Q}}(\mathbf{L}, \vec{t}, \vec{\tau}) \right) \mathcal{O}_{\mathcal{Q}}(\vec{n}, \vec{t}, \vec{\tau}) \quad (3.2.30)$$

Using the orthogonality relation (3.2.26), the above equation becomes

$$\begin{aligned} \sum_{\mathbf{L}} \chi_{\mathcal{Q}}(\mathbf{L}, \vec{s}, \vec{\sigma}) \mathcal{O}_{\mathcal{Q}}(\mathbf{L}) &= \sum_{\vec{t}} \sum_{\vec{\tau}} \left(\frac{1}{c_{\vec{n}}} \sum_{\vec{\eta} \times \vec{\rho}} \delta(\text{Adj}_{\vec{\eta} \times \vec{\rho}}(\vec{\sigma}) \vec{\tau}^{-1}) \delta_{\vec{\rho}(\vec{s}), \vec{t}} \right) \mathcal{O}_{\mathcal{Q}}(\vec{n}, \vec{t}, \vec{\tau}) \\ &= \frac{1}{c_{\vec{n}}} \sum_{\vec{\eta} \times \vec{\rho}} \mathcal{O}_{\mathcal{Q}}(\vec{n}, \vec{\rho}(\vec{s}), \text{Adj}_{\vec{\eta} \times \vec{\rho}}(\vec{\sigma})) = \frac{1}{c_{\vec{n}}} \sum_{\vec{\eta} \times \vec{\rho}} \mathcal{O}_{\mathcal{Q}}(\vec{n}, \vec{s}, \vec{\sigma}) \end{aligned} \quad (3.2.31)$$

where in the last line we used the constraint (3.1.15). Now the sum over the permutations $\vec{\eta}$, $\vec{\rho}$ is trivial, and it just gives a factor of $c_{\vec{n}}$. We then have that the inverse of the map (3.2.19) is simply

$$\mathcal{O}_{\mathcal{Q}}(\vec{n}, \vec{s}, \vec{\sigma}) = \sum_{\mathbf{L}} \chi_{\mathcal{Q}}(\mathbf{L}, \vec{s}, \vec{\sigma}) \mathcal{O}_{\mathcal{Q}}(\mathbf{L}) \quad (3.2.32)$$

3.3 Two and three point functions

In this section we will derive an expression for the two and three point function of matrix invariants, using the free field metric. All the computations are done using the Quiver Restricted Schur polynomials. The result for the two point function is rather compact, and offers a nice way to describe the Hilbert space of holomorphic GIOs. On the other hand, the expression for the three point function is still quite involved. We give a diagrammatic description of the answer in section 3.4, leaving the analytical expression and its derivation in Appendix A.3.

3.3.1 Hilbert space of holomorphic gauge invariant operators

In the free field metric, the Quiver Restricted Schur polynomials (3.2.19) form an orthogonal basis for the 2-point functions of holomorphic and anti-holomorphic matrix invariants. In this section we are going to show that

$$\langle \mathcal{O}_{\mathcal{Q}}(\mathbf{L}) \mathcal{O}_{\mathcal{Q}}^{\dagger}(\mathbf{L}') \rangle = \delta_{\mathbf{L}, \mathbf{L}'} c_{\vec{n}} \prod_a f_{N_a}(R_a) \quad (3.3.1)$$

where $c_{\vec{n}}$ is given in (3.2.27). The quantity $f_{N_a}(R_a)$ is the product of weights of the $U(N_a)$ representation R_a , and it is defined as

$$f_{N_a}(R_a) = \prod_{i,j} (N_a - i + j) \quad (3.3.2)$$

Here i and j label the row and column of the Young diagram R_a . At finite N_a , this quantity vanishes if the length of the first column of its Young diagram exceeds N_a , that is if $c_1(R_a) > N_a$. This means that for a generic quiver \mathcal{Q} the Hilbert space $\mathcal{H}_{\mathcal{Q}}$ of holomorphic GIOs can be described by

$$\mathcal{H}_{\mathcal{Q}} = \text{Span} \{ \mathcal{O}_{\mathcal{Q}}(\mathbf{L}) \mid \mathbf{L} \text{ s.t. } c_1(R_a) \leq N_a, \forall a \} \quad (3.3.3)$$

We can see how the finite N_a constraints of any matrix invariant are captured by the simple rule $c_1(R_a) \leq N_a$. We are now going to give a step-by-step derivation of this result.

i) Compute the correlator in the permutation basis

In this step we will compute the permutation basis correlator $\langle \mathcal{O}_{\mathcal{Q}}(\vec{n}, \vec{s}, \vec{\sigma}) \mathcal{O}_{\mathcal{Q}}^\dagger(\vec{n}, \vec{s}', \vec{\sigma}') \rangle$. In the free field metric, the only non-zero pairings are the ones that couple fields of the same kind (e.g. $\Phi_{ab,\alpha}$ with $\Phi_{ab,\alpha}^\dagger$):

$$\langle (\Phi_{ab,\alpha})_j^i (\Phi_{ab,\alpha}^\dagger)_l^k \rangle = \delta_l^i \delta_j^k, \quad \langle (Q_{a,\beta})_s^i (Q_{a,\beta}^\dagger)_l^p \rangle = \delta_l^i \delta_s^p, \quad \langle (\bar{Q}_{a,\gamma})_j^{\bar{s}} (\bar{Q}_{a,\gamma}^\dagger)_p^k \rangle = \delta_j^k \delta_p^{\bar{s}} \quad (3.3.4)$$

It then follows that

$$\left\langle \left(\Phi_{ab,\alpha}^{\otimes n_{ab,\alpha}} \right)_{J_{ab,\alpha}}^{I_{ab,\alpha}} \left(\Phi_{ab,\alpha}^\dagger \otimes n_{ab,\alpha} \right)_{I'_{ab,\alpha}}^{J'_{ab,\alpha}} \right\rangle = \sum_{\eta \in S_{n_{ab,\alpha}}} \delta_{I'_{ab,\alpha}}^{\eta(I_{ab,\alpha})} \delta_{\eta(J_{ab,\alpha})}^{J'_{ab,\alpha}} \quad (3.3.5)$$

where the sum over permutations represents all possible Wick contractions of the labels $I_{ab,\alpha} = \{i_1, \dots, i_{n_{ab,\alpha}}\}$, $J_{ab,\alpha} = \{j_1, \dots, j_{n_{ab,\alpha}}\}$. Using the identities

$$\begin{aligned} \delta_{I'_{ab,\alpha}}^{\eta(I_{ab,\alpha})} &= (\eta^{-1})_{I'_{ab,\alpha}}^{I_{ab,\alpha}} = (\eta)_{I_{ab,\alpha}}^{I'_{ab,\alpha}} = \delta_{I_{ab,\alpha}}^{\eta^{-1}(I'_{ab,\alpha})} \\ \delta_{\eta(J_{ab,\alpha})}^{J'_{ab,\alpha}} &= (\eta)_{J_{ab,\alpha}}^{J'_{ab,\alpha}} = (\eta^{-1})_{J'_{ab,\alpha}}^{J_{ab,\alpha}} = \delta_{\eta^{-1}(J'_{ab,\alpha})}^{J_{ab,\alpha}} \end{aligned} \quad (3.3.6)$$

it is immediate to write the correlators

$$\left\langle \left(\Phi_{ab,\alpha}^{\otimes n_{ab,\alpha}} \right)_{J_{ab,\alpha}}^{I_{ab,\alpha}} \left(\Phi_{ab,\alpha}^\dagger \otimes n_{ab,\alpha} \right)_{I'_{ab,\alpha}}^{J'_{ab,\alpha}} \right\rangle = \sum_{\eta \in S_{n_{ab,\alpha}}} (\eta^{-1})_{I'_{ab,\alpha}}^{I_{ab,\alpha}} (\eta)_{J_{ab,\alpha}}^{J'_{ab,\alpha}} \quad (3.3.7a)$$

$$\left\langle \left(Q_{a,\beta}^{\otimes n_{a,\beta}} \right)_{\mathbf{s}_{a,\beta}}^{I_{a,\beta}} \left(Q_{a,\beta}^\dagger \otimes n_{a,\beta} \right)_{I'_{a,\beta}}^{\mathbf{s}'_{a,\beta}} \right\rangle = \sum_{\rho \in S_{n_{a,\beta}}} (\rho^{-1})_{I'_{a,\beta}}^{I_{a,\beta}} (\rho)_{\mathbf{s}_{a,\beta}}^{\mathbf{s}'_{a,\beta}} = \sum_{\rho \in S_{n_{a,\beta}}} (\rho^{-1})_{I'_{a,\beta}}^{I_{a,\beta}} \delta_{\rho(\mathbf{s}_{a,\beta})}^{\mathbf{s}'_{a,\beta}} \quad (3.3.7b)$$

$$\left\langle \left(\bar{Q}_{a,\gamma}^{\otimes \bar{n}_{a,\gamma}} \right)_{\bar{J}_{a,\gamma}}^{\bar{s}_{a,\gamma}} \left(\bar{Q}_{a,\gamma}^\dagger \otimes \bar{n}_{a,\gamma} \right)_{\bar{J}'_{a,\gamma}}^{\bar{s}'_{a,\gamma}} \right\rangle = \sum_{\bar{\rho} \in S_{\bar{n}_{a,\gamma}}} (\bar{\rho}^{-1})_{\bar{J}'_{a,\gamma}}^{\bar{s}_{a,\gamma}} (\bar{\rho})_{\bar{J}_{a,\gamma}}^{\bar{s}'_{a,\gamma}} = \sum_{\bar{\rho} \in S_{\bar{n}_{a,\gamma}}} (\bar{\rho})_{\bar{J}_{a,\gamma}}^{\bar{s}'_{a,\gamma}} \delta_{\bar{\rho}(\bar{s}_{a,\gamma})}^{\bar{s}'_{a,\gamma}} \quad (3.3.7c)$$

We can now compute the pairing $\langle \mathcal{O}_{\mathcal{Q}}(\vec{n}, \vec{s}, \vec{\sigma}) \mathcal{O}_{\mathcal{Q}}^\dagger(\vec{n}, \vec{s}', \vec{\sigma}') \rangle$. We just need the Hermitean conjugated version of the operator defined in (3.1.12), which is simply

$$\begin{aligned} \mathcal{O}_{\mathcal{Q}}^\dagger(\vec{n}; \vec{s}; \vec{\sigma}) &= \prod_a \left[\prod_{b,\alpha} \left(\Phi_{ab,\alpha}^\dagger \otimes n_{ab,\alpha} \right)_{I_{ab,\alpha}}^{J_{ab,\alpha}} \right] \otimes \left[\prod_{\beta} \left(Q_{a,\beta}^\dagger \otimes n_{a,\beta} \right)_{I_{a,\beta}}^{\mathbf{s}_{a,\beta}} \right] \otimes \left[\prod_{\gamma} \left(\bar{Q}_{a,\gamma}^\dagger \otimes \bar{n}_{a,\gamma} \right)_{\bar{J}_{a,\gamma}}^{\bar{s}_{a,\gamma}} \right] \\ &\quad \times \prod_c (\sigma_c^{-1})_{\cup_{b,\alpha} I_{cb,\alpha} \cup_{\beta} I_{a,\beta} \cup_{b,\alpha} J_{bc,\alpha} \cup_{\gamma} \bar{J}_{a,\gamma}}^{\cup_{b,\alpha} I_{cb,\alpha} \cup_{\beta} I_{a,\beta}} \end{aligned} \quad (3.3.8)$$

where we used $(\sigma)_i^j = (\sigma^{-1})_j^i$. We then have

$$\begin{aligned}
 \langle \mathcal{O}_{\mathcal{Q}}(\vec{n}, \vec{s}, \vec{\sigma}) \mathcal{O}_{\mathcal{Q}}^\dagger(\vec{n}, \vec{s}', \vec{\sigma}') \rangle &= \sum_{\vec{\eta}, \vec{\rho}} \prod_a \left[\prod_{b,\alpha} \left(\eta_{ab,\alpha}^{-1} \right)_{I'_{ab,\alpha}}^{I_{ab,\alpha}} (\eta_{ab,\alpha})_{J_{ab,\alpha}}^{J'_{ab,\alpha}} \right] \left[\prod_{\beta} \left(\rho_{a,\beta}^{-1} \right)_{I'_{a,\beta}}^{I_{a,\beta}} \delta_{\vec{s}'_{a,\beta}}^{\rho_{a,\beta}(\vec{s}_{a,\beta})} \right] \\
 &\times \left[\prod_{\gamma} \left(\bar{\rho}_{a,\gamma} \right)_{\bar{J}_{a,\gamma}}^{\bar{J}'_{a,\gamma}} \delta_{\vec{s}'_{a,\gamma}}^{\bar{\rho}_{a,\gamma}(\vec{s}_{a,\gamma})} \right] (\sigma_a)_{\cup_{b,\alpha} I_{ab,\alpha} \cup_{\gamma} \bar{J}_{a,\gamma}}^{\cup_{b,\alpha} J_{ba,\alpha} \cup_{\gamma} \bar{J}'_{a,\gamma}} \left((\sigma'_a)^{-1} \right)_{\cup_{b,\alpha} J'_{ba,\alpha} \cup_{\gamma} \bar{J}'_{a,\gamma}}^{\cup_{b,\alpha} I'_{ab,\alpha} \cup_{\gamma} \bar{J}'_{a,\gamma}} \\
 &= \sum_{\vec{\eta}, \vec{\rho}} \prod_a \text{Tr}_{V_{N_a}^{\otimes n_a}} \left[\left(\times_{b,\alpha} \eta_{ba,\alpha} \times_{\gamma} \bar{\rho}_{a,\gamma} \right) \sigma_a \left(\times_{b,\alpha} \eta_{ab,\alpha}^{-1} \times_{\beta} \rho_{a,\beta}^{-1} \right) (\sigma'_a)^{-1} \right] \\
 &\times \left[\prod_{\beta} \delta_{\vec{s}'_{a,\beta}}^{\rho_{a,\beta}(\vec{s}_{a,\beta})} \right] \left[\prod_{\gamma} \delta_{\vec{s}'_{a,\gamma}}^{\bar{\rho}_{a,\gamma}(\vec{s}_{a,\gamma})} \right] \quad (3.3.9)
 \end{aligned}$$

where, as we defined in (3.1.16),

$$\vec{\eta} = \cup_{a,b,\alpha} \{ \eta_{ab,\alpha} \} \quad , \quad \eta_{ab,\alpha} \in S_{n_{ab,\alpha}} \quad (3.3.10a)$$

$$\vec{\rho} = \cup_a \{ \cup_{\beta} \rho_{a,\beta}; \cup_{\gamma} \bar{\rho}_{a,\gamma} \} \quad , \quad \rho_{a,\beta} \in S_{n_{a,\beta}} \quad , \quad \bar{\rho}_{a,\gamma} \in S_{\bar{n}_{a,\gamma}} \quad (3.3.10b)$$

The trace is taken over the product space $V_{N_a}^{\otimes n_a}$, V_{N_a} being the fundamental representation of $U(N_a)$ and $n_a = \sum_{b,\alpha} n_{ab,\alpha} + \sum_{\beta} n_{a,\beta}$. Recalling the definition (3.1.17) and the identity

$$\text{Tr}_{V_N^{\otimes n}} (\sigma) = N^{C[\sigma]} \quad (3.3.11)$$

where $C[\sigma]$ is the number of cycles in the permutation σ , we finally get

$$\langle \mathcal{O}_{\mathcal{Q}}(\vec{n}, \vec{s}, \vec{\sigma}) \mathcal{O}_{\mathcal{Q}}^\dagger(\vec{n}, \vec{s}', \vec{\sigma}') \rangle = \sum_{\vec{\eta}, \vec{\rho}} \prod_a \left[\prod_{\beta} \delta_{\vec{s}'_{a,\beta}}^{\rho_{a,\beta}(\vec{s}_{a,\beta})} \right] \left[\prod_{\gamma} \delta_{\vec{s}'_{a,\gamma}}^{\bar{\rho}_{a,\gamma}(\vec{s}_{a,\gamma})} \right] N_a^{C[\text{Adj}_{\vec{\eta} \times \vec{\rho}}(\sigma_a) (\sigma'_a)^{-1}]} \quad (3.3.12)$$

ii) Fourier transform the permutation basis correlator

Using the definition of the Fourier transformed operator (3.2.19), we can immediately write

$$\begin{aligned}
 \langle \mathcal{O}_{\mathcal{Q}}(\mathbf{L}) \mathcal{O}_{\mathcal{Q}}^\dagger(\mathbf{L}') \rangle &= \sum_{\vec{s}, \vec{s}'} \sum_{\vec{\sigma}, \vec{\sigma}'} \chi_{\mathcal{Q}}(\mathbf{L}, \vec{s}, \vec{\sigma}) \chi_{\mathcal{Q}}^\dagger(\mathbf{L}', \vec{s}', \vec{\sigma}') \langle \mathcal{O}_{\mathcal{Q}}(\vec{n}, \vec{s}, \vec{\sigma}) \mathcal{O}_{\mathcal{Q}}^\dagger(\vec{n}, \vec{s}', \vec{\sigma}') \rangle \quad (3.3.13) \\
 &= \sum_{\vec{s}} \sum_{\vec{\sigma}, \vec{\sigma}'} \sum_{\vec{\eta}, \vec{\rho}} \chi_{\mathcal{Q}}(\mathbf{L}, \vec{s}, \vec{\sigma}) \chi_{\mathcal{Q}}(\mathbf{L}', \vec{\rho}(\vec{s}), \vec{\sigma}') \prod_a N_a^{C[\text{Adj}_{\vec{\eta} \times \vec{\rho}}(\sigma_a) (\sigma'_a)^{-1}]}
 \end{aligned}$$

where we summed over \vec{s}' , used the Kronecker delta functions and used the reality of the quiver characters. Now redefining the dummy variable $\vec{s} \rightarrow \vec{\rho}^{-1}(\vec{s})$ in (3.3.13) we further obtain

$$\begin{aligned}
 & \langle \mathcal{O}_{\mathcal{Q}}(\mathbf{L}) \mathcal{O}_{\mathcal{Q}}^{\dagger}(\mathbf{L}') \rangle \\
 &= \sum_{\vec{s}} \sum_{\vec{\sigma}, \vec{\sigma}'} \sum_{\vec{\eta}, \vec{\rho}} \chi_{\mathcal{Q}}(\mathbf{L}, \vec{\rho}^{-1}(\vec{s}), \vec{\sigma}) \chi_{\mathcal{Q}}(\mathbf{L}', \vec{s}, \vec{\sigma}') \prod_a N_a^{C[\text{Adj}_{\vec{\eta} \times \vec{\rho}}(\sigma_a)(\sigma'_a)^{-1}]} \\
 &= \sum_{\vec{s}} \sum_{\vec{\sigma}, \vec{\sigma}'} \sum_{\vec{\eta}, \vec{\rho}} \chi_{\mathcal{Q}}(\mathbf{L}, \vec{s}, \text{Adj}_{\vec{\eta} \times \vec{\rho}}(\vec{\sigma})) \chi_{\mathcal{Q}}(\mathbf{L}', \vec{s}, \vec{\sigma}') \prod_a N_a^{C[\text{Adj}_{\vec{\eta} \times \vec{\rho}}(\sigma_a)(\sigma'_a)^{-1}]} \\
 &= \sum_{\vec{s}} \sum_{\vec{\sigma}, \vec{\sigma}'} \sum_{\vec{\eta}, \vec{\rho}} \chi_{\mathcal{Q}}(\mathbf{L}, \vec{s}, \vec{\sigma}) \chi_{\mathcal{Q}}(\mathbf{L}', \vec{s}, \vec{\sigma}') \prod_a N_a^{C[\sigma_a(\sigma'_a)^{-1}]} \tag{3.3.14}
 \end{aligned}$$

To get the second equality we used the invariance relation (3.2.23), and in the third we relabelled the dummy variable $\vec{\sigma} \rightarrow \text{Adj}_{\vec{\rho} \times \vec{\eta}}(\vec{\sigma})$. We then see that the dependence on the permutations $\vec{\eta}$ and $\vec{\rho}$ drops out, so that their sums can be trivially computed to obtain

$$\begin{aligned}
 \langle \mathcal{O}_{\mathcal{Q}}(\mathbf{L}) \mathcal{O}_{\mathcal{Q}}^{\dagger}(\mathbf{L}') \rangle &= \sum_{\vec{s}} \sum_{\vec{\sigma}, \vec{\sigma}'} \chi_{\mathcal{Q}}(\mathbf{L}, \vec{s}, \vec{\sigma}) \chi_{\mathcal{Q}}(\mathbf{L}', \vec{s}, \vec{\sigma}') \\
 &\quad \times \prod_a \left(\prod_{b, \alpha} n_{ab, \alpha}! \right) \left(\prod_{\beta} n_{a, \beta}! \right) \left(\prod_{\gamma} \bar{n}_{a, \gamma}! \right) N_a^{C[\sigma_a(\sigma'_a)^{-1}]} \tag{3.3.15}
 \end{aligned}$$

Now let us relabel $\sigma_a \rightarrow \tau_a \cdot \sigma'_a$ and use the definition of $c_{\vec{n}}$ given in (3.2.27) to get

$$\langle \mathcal{O}_{\mathcal{Q}}(\mathbf{L}) \mathcal{O}_{\mathcal{Q}}^{\dagger}(\mathbf{L}') \rangle = c_{\vec{n}} \sum_{\vec{s}} \sum_{\vec{\tau}, \vec{\sigma}'} \chi_{\mathcal{Q}}(\mathbf{L}, \vec{s}, \vec{\tau} \cdot \vec{\sigma}') \chi_{\mathcal{Q}}(\mathbf{L}', \vec{s}, \vec{\sigma}') \prod_a N_a^{C[\tau_a]} \tag{3.3.16}$$

The only dependence on $\vec{\sigma}'$ and \vec{s} is now inside the two quiver characters. We have therefore reduced the problem of computing the holomorphic-antiholomorphic GIO pairing to the one of computing the sum of a product of characters. This is done in the next step, and involves using the quiver character orthogonality relations.

iii) Use the quiver character orthogonality relations

We are now going to use the quiver character orthogonality relation eq. (A.2.15):

$$\begin{aligned}
 & \sum_{\vec{s}} \sum_{\vec{\sigma}'} \chi_{\mathcal{Q}}(\mathbf{L}, \vec{s}, \vec{\tau} \cdot \vec{\sigma}') \chi_{\mathcal{Q}}(\mathbf{L}', \vec{s}, \vec{\sigma}') \\
 &= c_{\mathbf{L}} c_{\mathbf{L}'} \prod_a \frac{n_a!}{d(R_a)} \text{Tr} \left(D^{R_a}(\tau_a) P_{R_a \rightarrow \cup_{b,\alpha} r_{ba,\alpha} \cup_{\gamma} \bar{r}_{a,\gamma}}^{\nu_a^+, \nu_a^{+'}} \right) \delta_{R_a, R_a'} \\
 & \quad \times \left(\prod_{b,\alpha} \delta_{r_{ab,\alpha}, r'_{ab,\alpha}} \right) \left(\prod_{\beta} d(r_{a,\beta}) \delta_{r_{a,\beta}, r'_{a,\beta}} \delta_{S_{a,\beta}, S'_{a,\beta}} \right) \left(\prod_{\gamma} \delta_{\bar{r}_{a,\gamma}, \bar{r}'_{a,\gamma}} \delta_{\bar{S}_{a,\gamma}, \bar{S}'_{a,\gamma}} \right) \delta_{\nu_a^-, \nu_a'^{-}}
 \end{aligned} \tag{3.3.17}$$

to explicitly compute the pairing (3.3.16). We will also need to use the identity

$$\sum_{\tau_a} \text{Tr} \left(D^{R_a}(\tau_a) P_{R_a \rightarrow \cup_{b,\alpha} r_{ba,\alpha} \cup_{\gamma} \bar{r}_{a,\gamma}}^{\nu_a^+, \nu_a^{+'}} \right) N_a^{c[\tau_a]} = \delta_{\nu_a^+, \nu_a^{+'}} \left(\prod_{b,\alpha} d(r_{ba,\alpha}) \right) \left(\prod_{\gamma} d(\bar{r}_{a,\gamma}) \right) f_{N_a}(R_a) \tag{3.3.18}$$

a proof of which can be found in *e.g.* [83]. Inserting eqs. (3.3.17) and (3.3.18) in (3.3.16) we finally get

$$\begin{aligned}
 \langle \mathcal{O}_{\mathcal{Q}}(\mathbf{L}) \mathcal{O}_{\mathcal{Q}}^{\dagger}(\mathbf{L}') \rangle &= c_{\vec{n}} c_{\mathbf{L}} c_{\mathbf{L}'} \prod_a \frac{n_a!}{d(R_a)} \delta_{R_a, R_a'} \delta_{\nu_a^-, \nu_a'^{-}} \delta_{\nu_a^+, \nu_a^{+'}} \left(\prod_{b,\alpha} d(r_{ab,\alpha}) \delta_{r_{ab,\alpha}, r'_{ab,\alpha}} \right) \\
 & \quad \times \left(\prod_{\beta} d(r_{a,\beta}) \delta_{r_{a,\beta}, r'_{a,\beta}} \delta_{S_{a,\beta}, S'_{a,\beta}} \right) \left(\prod_{\gamma} \bar{d}(\bar{r}_{a,\gamma}) \delta_{\bar{r}_{a,\gamma}, \bar{r}'_{a,\gamma}} \delta_{\bar{S}_{a,\gamma}, \bar{S}'_{a,\gamma}} \right) f_{N_a}(R_a) \\
 &= \delta_{\mathbf{L}, \mathbf{L}'} c_{\vec{n}} c_{\mathbf{L}}^2 \prod_a \frac{n_a!}{d(R_a)} \left(\prod_{b,\alpha} d(r_{ab,\alpha}) \right) \left(\prod_{\beta} d(r_{a,\beta}) \right) \left(\prod_{\gamma} \bar{d}(\bar{r}_{a,\gamma}) \right) f_{N_a}(R_a)
 \end{aligned} \tag{3.3.19}$$

which, using the normalisation constant $c_{\mathbf{L}}$ defined in (3.2.21), reduces to eq. (3.3.1):

$$\langle \mathcal{O}_{\mathcal{Q}}(\mathbf{L}) \mathcal{O}_{\mathcal{Q}}^{\dagger}(\mathbf{L}') \rangle = \delta_{\mathbf{L}, \mathbf{L}'} c_{\vec{n}} \prod_a f_{N_a}(R_a) \tag{3.3.20}$$

The orthogonality of the Fourier transformed operators is thus proven.

3.4 Chiral ring structure constants and three point functions

In Appendix A.3 we derive an equation for the holomorphic GIO ring structure constants $G_{\mathbf{L}^{(1)}, \mathbf{L}^{(2)}, \mathbf{L}^{(3)}}$, defined as the coefficients of the operator product expansion

$$\mathcal{O}_{\mathcal{Q}}(\mathbf{L}^{(1)}) \mathcal{O}_{\mathcal{Q}}(\mathbf{L}^{(2)}) = \sum_{\mathbf{L}^{(3)}} G_{\mathbf{L}^{(1)}, \mathbf{L}^{(2)}, \mathbf{L}^{(3)}} \mathcal{O}_{\mathcal{Q}}(\mathbf{L}^{(3)}) \quad (3.4.1)$$

Because of the orthogonality of the two point function (3.3.1), we also obtain an equation for the three point function:

$$\left\langle \mathcal{O}_{\mathcal{Q}}(\mathbf{L}^{(1)}) \mathcal{O}_{\mathcal{Q}}(\mathbf{L}^{(2)}) \mathcal{O}_{\mathcal{Q}}^{\dagger}(\mathbf{L}^{(3)}) \right\rangle = c_{\vec{n}^{(3)}} G_{\mathbf{L}^{(1)}, \mathbf{L}^{(2)}, \mathbf{L}^{(3)}} \prod_a f_{N_a} \left(R_a^{(3)} \right) \quad (3.4.2)$$

We only give here a pictorial interpretation of the equation we derived for $G_{\mathbf{L}^{(1)}, \mathbf{L}^{(2)}, \mathbf{L}^{(3)}}$, leaving the technicalities in Appendix A.3. In particular, eq. (A.3.45) gives the analytical formula for the $G_{\mathbf{L}^{(1)}, \mathbf{L}^{(2)}, \mathbf{L}^{(3)}}$ coefficients.

Let us begin by considering an example. We will show how to draw the diagram for the chiral ring structure constants for an $\mathcal{N} = 2$ SCQD, through a step-by-step procedure. The quiver for this theory is shown in Fig. 20. As we discussed in the previous section, for any given model, a basis of GIOs is labelled by $\mathbf{L} = \{R_a, r_{ab, \alpha}, r_{a, \beta}, S_{a, \beta}, \bar{r}_{a, \gamma}, \bar{S}_{a, \gamma}, \nu_a^+, \nu_a^-\}$. However, for an $\mathcal{N} = 2$ SQCD theory, many of these $a, b, \alpha, \beta, \gamma$ indices are redundant: for this reason we can simplify \mathbf{L} as

$$\mathbf{L} = \{R, r, r_q, S, \bar{r}_q, \bar{S}, \nu^+, \nu^-\} \quad (3.4.3)$$

Here r is the representation associated with the adjoint field ϕ ; S denotes a state in the $SU(F)$ representation r_q and \bar{S} denotes a state in the $SU(F)$ representation \bar{r}_q . R is the representation associated with the gauge group, $U(N)$. We therefore want to compute the three point function (3.4.2), where all the $\mathbf{L}^{(i)}$, $i = 1, 2, 3$, are of the form given in (3.4.3). We split this process into five steps, that we now describe.

- i) **Create the split node quiver diagram.** The first step is to create the split-node quiver diagram from the $\mathcal{N} = 2$ SCQD quiver of Fig. 20. This involves separating the gauge node into two components, one that collects all the incoming edges and one from which all the edges exit. The former is called a positive node of the split-node quiver, the latter is called a negative node. These two are then joined by an edge, called a gauge edge, directed from the positive to the negative node. We then decorate all the edges in the split-node quiver with symmetric group representation labels. The positive and negative nodes in the split-node diagram are points where the edges meet. Since the edges now carry a symmetric group representation, we interpret them as representation branching points, to which we associate a branching coefficient (3.2.4). To the positive node we associate the branching multiplicity ν^+ , to the negative node we associate the branching multiplicity ν^- . Finally, we label the open endpoints of the quark and antiquark edges

with $U(F)$ fundamental and antifundamental representation state labels, S and \bar{S} . The resulting diagram is shown on the left of Fig. 30. Notice that such a diagram contains all the labels in $\mathbf{L} = \{R, r, r_q, S, \bar{r}_q, \bar{S}, \nu^+, \nu^-\}$.

- ii) **Cut the edges in the split-node quiver.** In this step we will cut all the edges in the split-node diagram, as shown in the middle picture of Fig. 30. After all the cuts have been performed, we are left with two trivalent vertices and two edges corresponding to the quark and the antiquark fields. As previously stated, the trivalent vertices will be interpreted as branching coefficients (see Fig. 23). We group these four object into two pairs, depending whether their edges are connected to the positive or negative node of the split-node diagram. This is shown in the rightmost picture of Fig. 30.

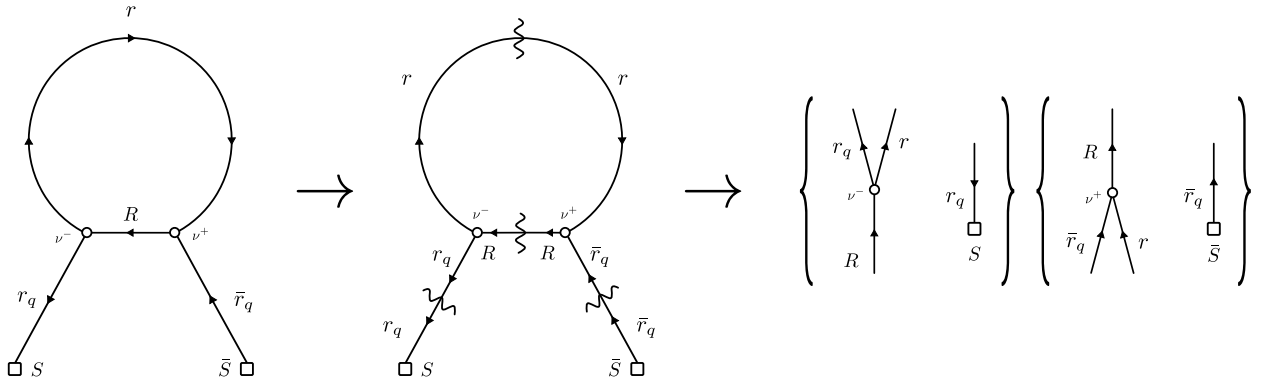

Figure 30: From left to right: the split-node quiver for the $\mathcal{N} = 2$ SQCD, the same diagram with the cut edges, and the two components of the negative and positive node of the split-node quiver.

- iii) **Merge the edges connected to the negative node.** We consider the set of edges connected to the negative node of the split-node quiver. In order to compute the three point function (3.4.2), we need three copies of these sets, one for each field $\mathcal{O}_{\mathcal{Q}}(\mathbf{L}^{(1)})$, $\mathcal{O}_{\mathcal{Q}}(\mathbf{L}^{(2)})$, $\mathcal{O}_{\mathcal{Q}}^{\dagger}(\mathbf{L}^{(3)})$. These sets are shown in Fig. 31. The orientation of the edges in the last pair is reversed: this is because the third field on the LHS of (3.4.2) is hermitian conjugate.

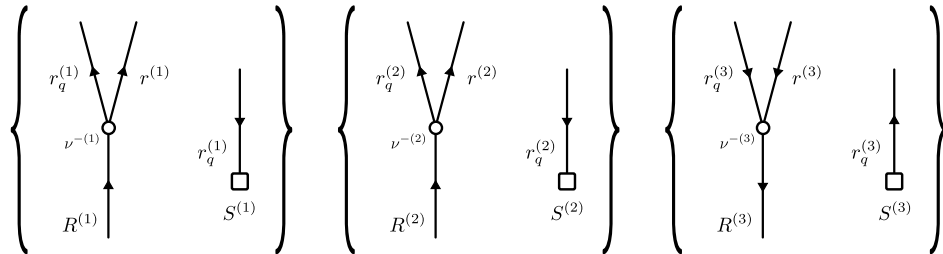

Figure 31: The three sets of trivalent vertices and edges needed to construct part of the $\mathcal{N} = 2$ SQCD three point function diagram.

We will now suitably merge the three trivalent vertices (branching coefficients) in Fig. 31, and join the three edges corresponding to the quark fields. The outcome of this

fusing process is shown in Fig. 32. We introduced three new trivalent vertices, which as usual we interpret as branching coefficients: the labels μ , ν_r and ν_q denote their multiplicity. The fusing of the three quark edges has been achieved by introducing a Clebsch-Gordan coefficient, see Fig. 24. We further impose that the label for the multiplicity of the representation branching $r_q^{(1)} \otimes r_q^{(2)} \rightarrow r_q^{(3)}$ is the same in both the Clebsch-Gordan coefficient and the branching coefficient that appear in Fig. 31. In the figure we also inserted a permutation λ_- in the edge carrying the representation $R^{(3)}$. The purpose of this permutation is to rearrange tensor factors given the two different factorisation of $R^{(3)}$, that is from $(r^{(1)} \otimes r^{(1)}) \otimes (r_q^{(2)} \otimes r_q^{(2)}) \rightarrow r^{(3)} \otimes r_q^{(3)} \rightarrow R^{(3)}$ to $R^{(3)} \rightarrow R^{(1)} \otimes R^{(2)} \rightarrow (r^{(1)} \otimes r_q^{(1)}) \otimes (r^{(2)} \otimes r_q^{(2)})$.

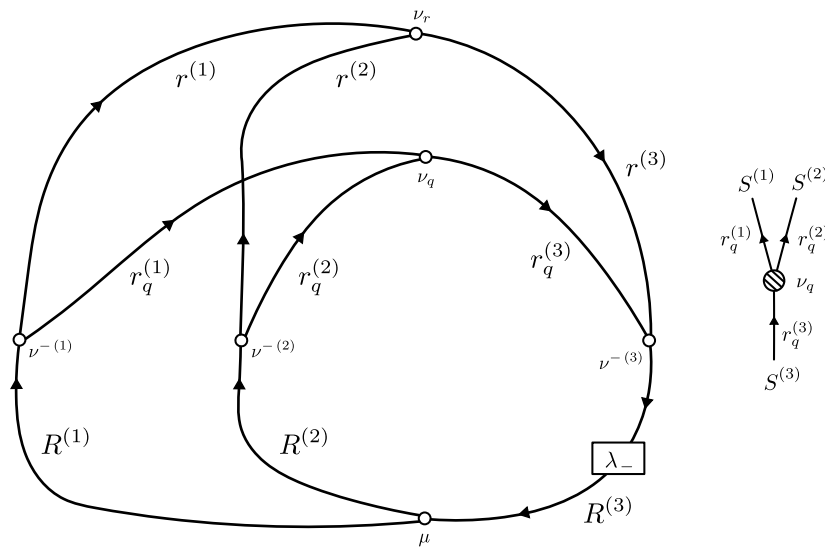

Figure 32: Merging of branching coefficients and quarks labels for the three sets in Fig. 31.

We thus obtained a closed network of branching coefficients, together with a single $SU(F)$ Clebsch-Gordan coefficient. All the edges involved into this process were the ones connected to the negative node of the split-node diagram they belonged to.

- iv) **Merge the edges connected to the positive node.** By repeating the fusing process presented in point iii) for all the edges connected to the positive node of the split-node quiver, we obtain a diagram very similar to the one in Fig. 32. The only rule that we impose is that the multiplicity labels for representation branchings which appear in both these diagrams have to be the same. In our example, the branching of $R^{(3)}$ into $R^{(1)}$ and $R^{(2)}$ will appear in both diagrams. This is because the edge carrying the representation label R is connected to both the positive and negative node of the split-node quiver, as it can be seen from Fig. 30. Therefore these two branching coefficients will share the same multiplicity label, μ . Similarly, the branching of $r^{(1)}$ and $r^{(2)}$ into $r^{(3)}$ will be present in both diagrams too. Following the same rule, these two branching coefficients will then have the same multiplicity label, ν_r .

v) **Combine the diagrams and sum over multiplicities.** To obtain the final expression for the three point function, we just need put together the two diagram we obtained in the steps iv) and v) and sum over the multiplicities μ, ν_r, ν_q and $\bar{\nu}_q$. This final diagram is shown in Fig. 33.

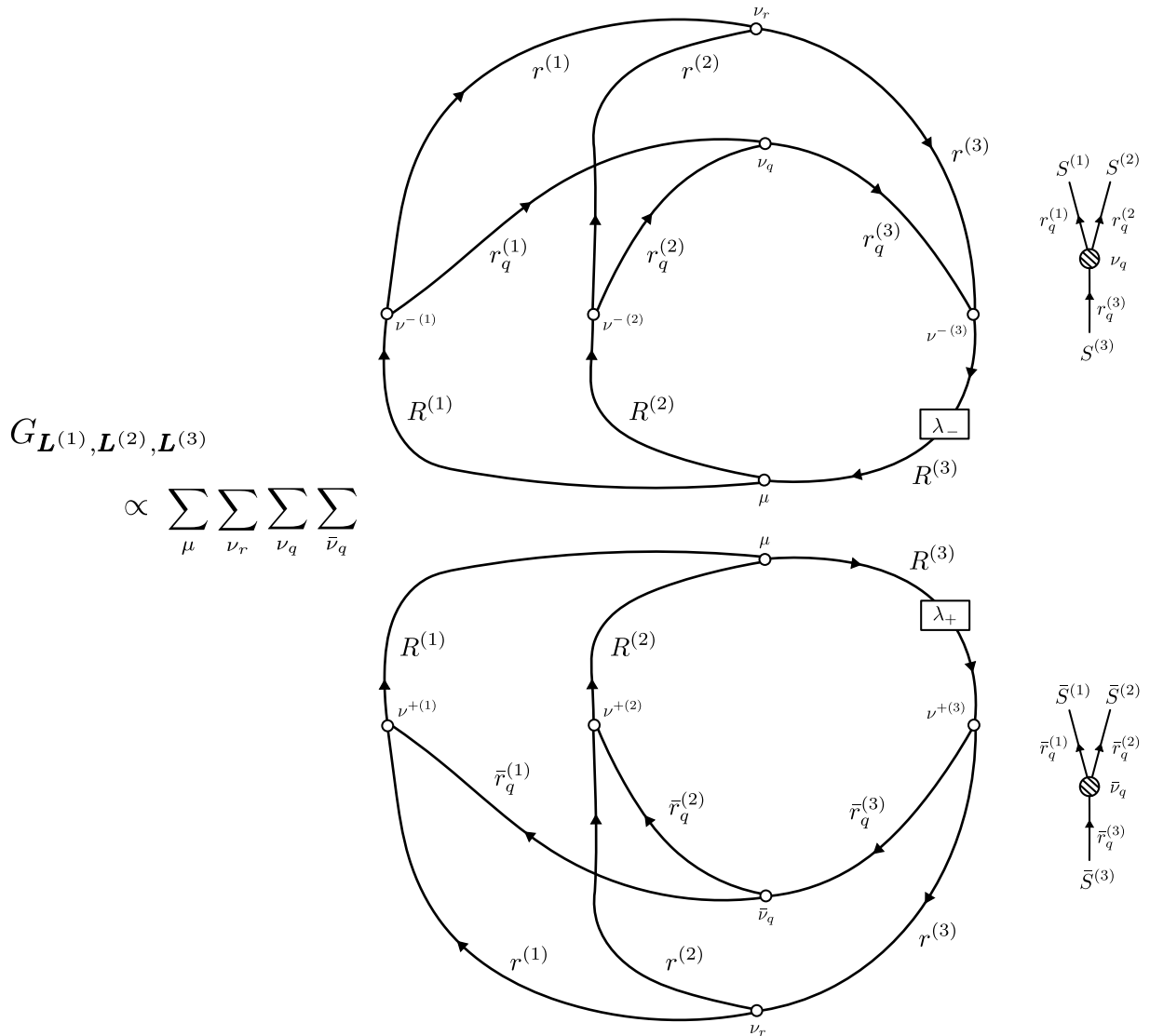

Figure 33: The diagram of the three point function (3.4.2) for the $\mathcal{N} = 2$ SQCD.

In Appendix 3.4.1 we give a purely diagrammatic derivation of this result. We can see how the answer for the three point function factorises into two components: the former features only edges connected to the negative node of the split-node diagram, the latter only involves edges connected to its positive node. The same behaviour can be observed in the answer for the three point function of matrix invariants of generic quivers. We are now going to present this general result. The diagram for the three point function (3.4.2) is shown in Fig. 34.

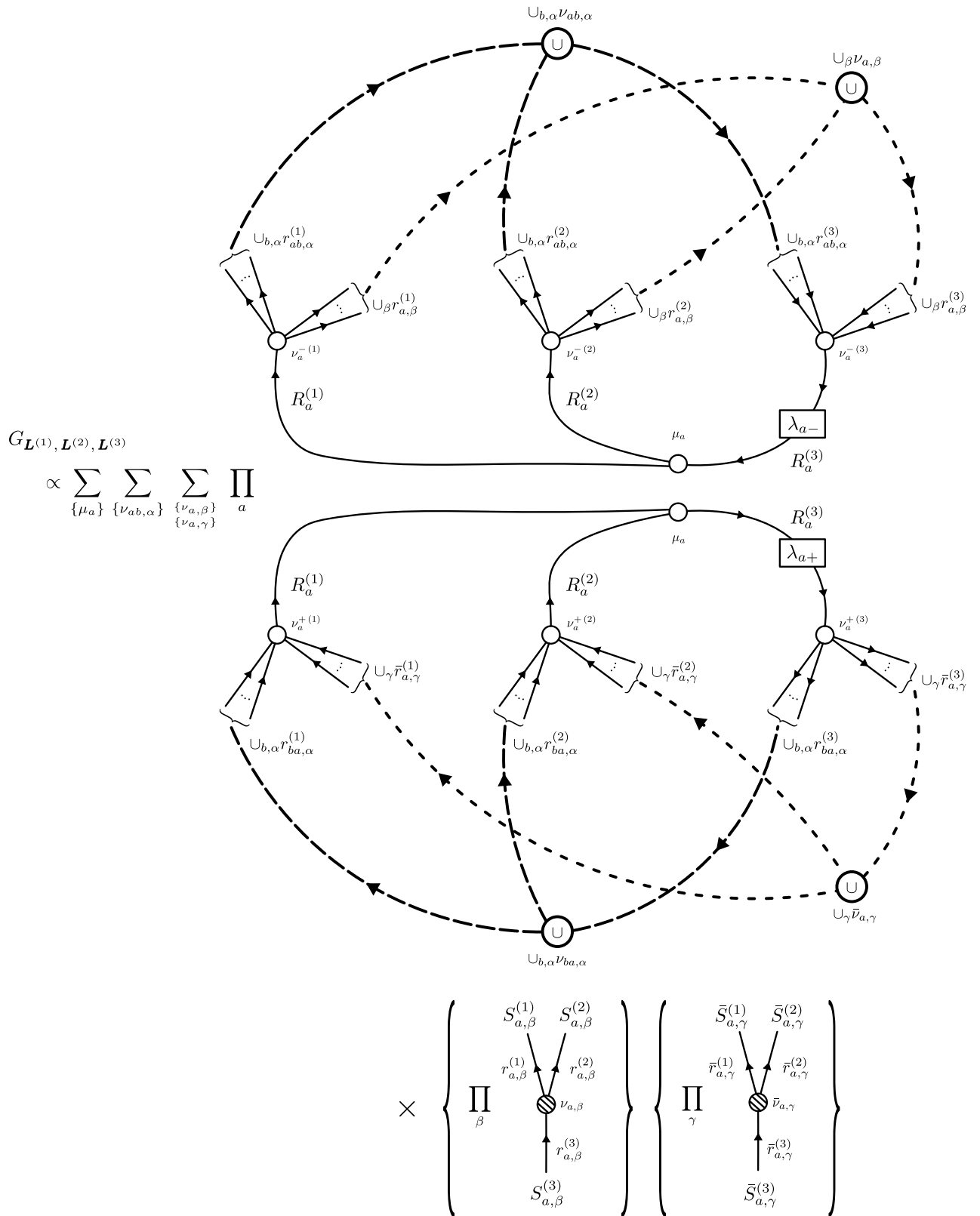

Figure 34: Pictorial description of the expression for the holomorphic GIO ring structure constants $G_{\mathbf{L}^{(1)}, \mathbf{L}^{(2)}, \mathbf{L}^{(3)}}$, corresponding to eq. (A.3.45).

In drawing this picture we used the diagrammatic shorthand notation displayed in Fig. 35.

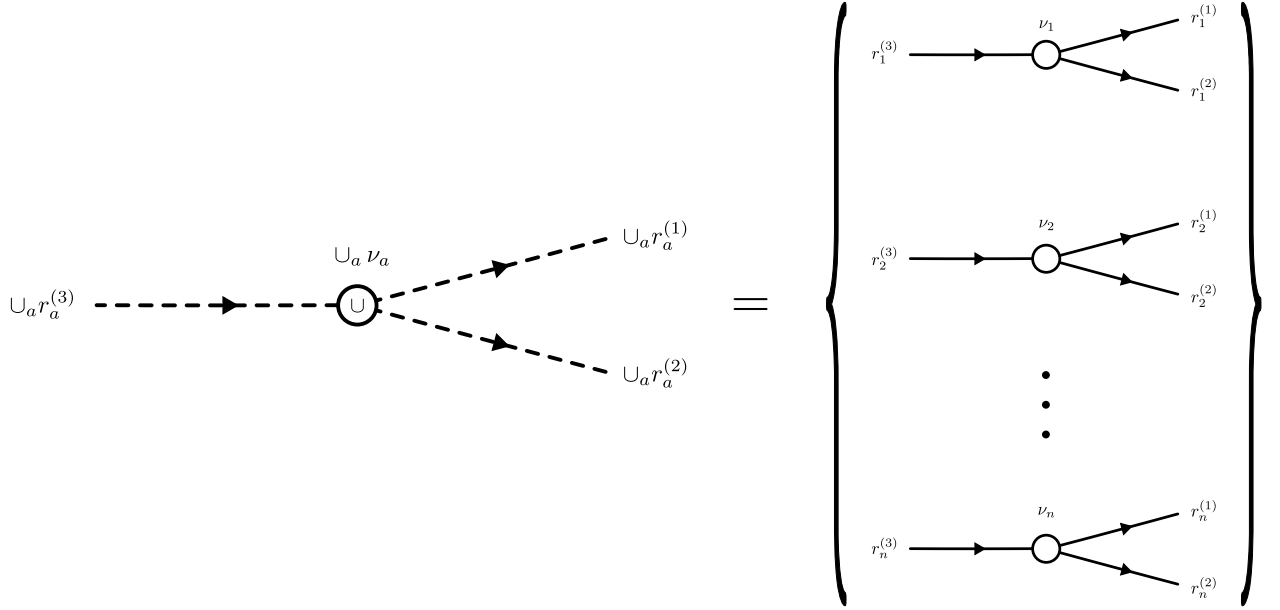

Figure 35: A shorthand notation for a collection of branching coefficients.

The λ_{a-} and λ_{a+} in Fig. 34 are permutations of $n_a^{(3)}$ elements, defined by the equations (A.3.2) and (A.3.3). Figure 34 shows that the holomorphic GIO ring structure constants factorise into a product over all the gauge nodes a of the quiver. Each one of these terms, whose diagrammatic interpretation is drawn in the figure, further factorises into a product of two components. They correspond to the positive and negative nodes of the split node a , with $a = 1, 2, \dots, n$ (see also Fig. 22). Notice that the multiplicity labels μ_a , $\nu_{ab,\alpha}$, $\nu_{a,\beta}$ and $\bar{\nu}_{a,\gamma}$ always appear in pairs. For example, μ_a appears both in the upper and lower (disconnected) parts of the split-node a diagram. In the same diagram, $\nu_{a,\beta}$ appears in both a symmetric group branching coefficient and in a Clebsch-Gordan coefficient.

By inspecting Fig. 34 we can write four selection rules for the holomorphic GIO ring structure constants:

- i) upon the restriction $S_{n_a^{(3)}} \Big|_{H_a}$, where $H_a = S_{n_a^{(1)}} \times S_{n_a^{(2)}}$, the $S_{n_a^{(3)}}$ representation $R_a^{(3)}$ becomes reducible. This reduction must contain the tensor product representation $R_a^{(1)} \otimes R_a^{(2)}$, $\forall a$. This implies the constraint $g(R_a^{(1)}, R_a^{(2)}; R_a^{(3)}) \neq 0$, $\forall a$.
- ii) upon the restriction $S_{n_{ab,\alpha}^{(3)}} \Big|_{H_{ab,\alpha}}$, where $H_{ab,\alpha} = S_{n_{ab,\alpha}^{(1)}} \times S_{n_{ab,\alpha}^{(2)}}$, the $S_{n_{ab,\alpha}^{(3)}}$ representation $r_{ab,\alpha}^{(3)}$ becomes reducible. This reduction must contain the tensor product representation $r_{ab,\alpha}^{(1)} \otimes r_{ab,\alpha}^{(2)}$, $\forall a, b, \alpha$. This implies the constraint $g(r_{ab,\alpha}^{(1)}, r_{ab,\alpha}^{(2)}; r_{ab,\alpha}^{(3)}) \neq 0$, $\forall a, b, \alpha$.
- iii) upon the restriction $S_{n_{a,\beta}^{(3)}} \Big|_{H_{a,\beta}}$, where $H_{a,\beta} = S_{n_{a,\beta}^{(1)}} \times S_{n_{a,\beta}^{(2)}}$, the $S_{n_{a,\beta}^{(3)}}$ representation $r_{a,\beta}^{(3)}$ becomes reducible. This reduction must contain the tensor product representation $r_{a,\beta}^{(1)} \otimes$

$r_{a,\beta}^{(2)}, \forall a, \beta$. This implies the constraint $g(r_{a,\beta}^{(1)}, r_{a,\beta}^{(2)}; r_{a,\beta}^{(3)}) \neq 0, \forall a, \beta$.

- iv) upon the restriction $S_{\bar{n}_{a,\gamma}^{(3)}} \Big|_{H_{a,\gamma}}$, where $H_{a,\gamma} = S_{\bar{n}_{a,\gamma}^{(1)}} \times S_{\bar{n}_{a,\gamma}^{(2)}}$, the $S_{\bar{n}_{a,\gamma}^{(3)}}$ representation $\bar{r}_{a,\gamma}^{(3)}$ becomes reducible. This reduction must contain the tensor product representation $\bar{r}_{a,\gamma}^{(1)} \otimes \bar{r}_{a,\gamma}^{(2)}, \forall a, \gamma$. This implies the constraint $g(\bar{r}_{a,\gamma}^{(1)}, \bar{r}_{a,\gamma}^{(2)}; \bar{r}_{a,\gamma}^{(3)}) \neq 0, \forall a, \gamma$.

All these rules are enforced by the branching coefficients networks in Fig. 34. Given two matrix invariants labelled by $\mathbf{L}^{(1)}$ and $\mathbf{L}^{(2)}$ respectively, we conclude that $G_{\mathbf{L}^{(1)}, \mathbf{L}^{(2)}, \mathbf{L}^{(3)}} \neq 0$ if and only if $\mathbf{L}^{(3)}$ satisfies the selection rules i) - iv) above.

3.4.1 Diagrammatic derivation for an $\mathcal{N} = 2$ SQCD

We are now going to present a diagrammatic derivation of the chiral ring structure constants for the example of an $\mathcal{N} = 2$ SQCD, already discussed in the previous section 3.4. Our starting point is the analytic expression (A.3.11), where each $\mathbf{L}^{(i)}$ has been simplified as in eq. (3.4.3). We can depict this quantity as in Fig. 36.

$$\begin{aligned}
 & G_{\mathbf{L}^{(1)}, \mathbf{L}^{(2)}, \mathbf{L}^{(3)}} \\
 &= \sum_{\substack{\mathbf{s}^{(1)}, \mathbf{s}^{(2)} \\ \bar{\mathbf{s}}^{(1)}, \bar{\mathbf{s}}^{(2)}}} \sum_{\sigma^{(1)}, \sigma^{(2)}}
 \end{aligned}
 \left(
 \begin{array}{c}
 \begin{array}{c}
 \text{Diagram 1: } R^{(1)} \text{ node with } \nu^{+(1)}, \nu^{-(1)} \text{ and } \sigma^{(1)} \text{ box.} \\
 \text{Inputs: } r^{(1)} \text{ (loop), } r_q^{(1)} \text{ (arrow).} \\
 \text{Outputs: } \bar{r}_q^{(1)}, \bar{\mathbf{s}}^{(1)}, \mathbf{s}^{(1)}, S^{(1)}.
 \end{array} \\
 \begin{array}{c}
 \text{Diagram 2: } R^{(2)} \text{ node with } \nu^{+(2)}, \nu^{-(2)} \text{ and } \sigma^{(2)} \text{ box.} \\
 \text{Inputs: } r^{(2)} \text{ (loop), } r_q^{(2)} \text{ (arrow).} \\
 \text{Outputs: } \bar{r}_q^{(2)}, \bar{\mathbf{s}}^{(2)}, \mathbf{s}^{(2)}, S^{(2)}.
 \end{array} \\
 \begin{array}{c}
 \text{Diagram 3: } R^{(3)} \text{ node with } \nu^{+(3)}, \nu^{-(3)} \text{ and } \lambda_+^{-1}(\sigma^{(1)} \times \sigma^{(2)}) \lambda_-^{-1} \text{ box.} \\
 \text{Inputs: } r^{(3)} \text{ (loop), } r_q^{(3)} \text{ (arrow).} \\
 \text{Outputs: } \bar{r}_q^{(3)}, \bar{\mathbf{s}}^{(1)} \cup \bar{\mathbf{s}}^{(2)}, \mathbf{s}^{(1)} \cup \mathbf{s}^{(2)}, S^{(3)}.
 \end{array}
 \end{array}
 \right)$$

Figure 36: Diagrammatic representation of the chiral ring structure constants for an $\mathcal{N} = 2$ SQCD, corresponding to eq. (A.3.11).

After using identity (A.3.14), which is represented in Fig. 44, the diagram is transformed to the one in Fig. 37. We see that now the three disjoint diagrams of the previous Fig. 36 are now joined into a single connected component.

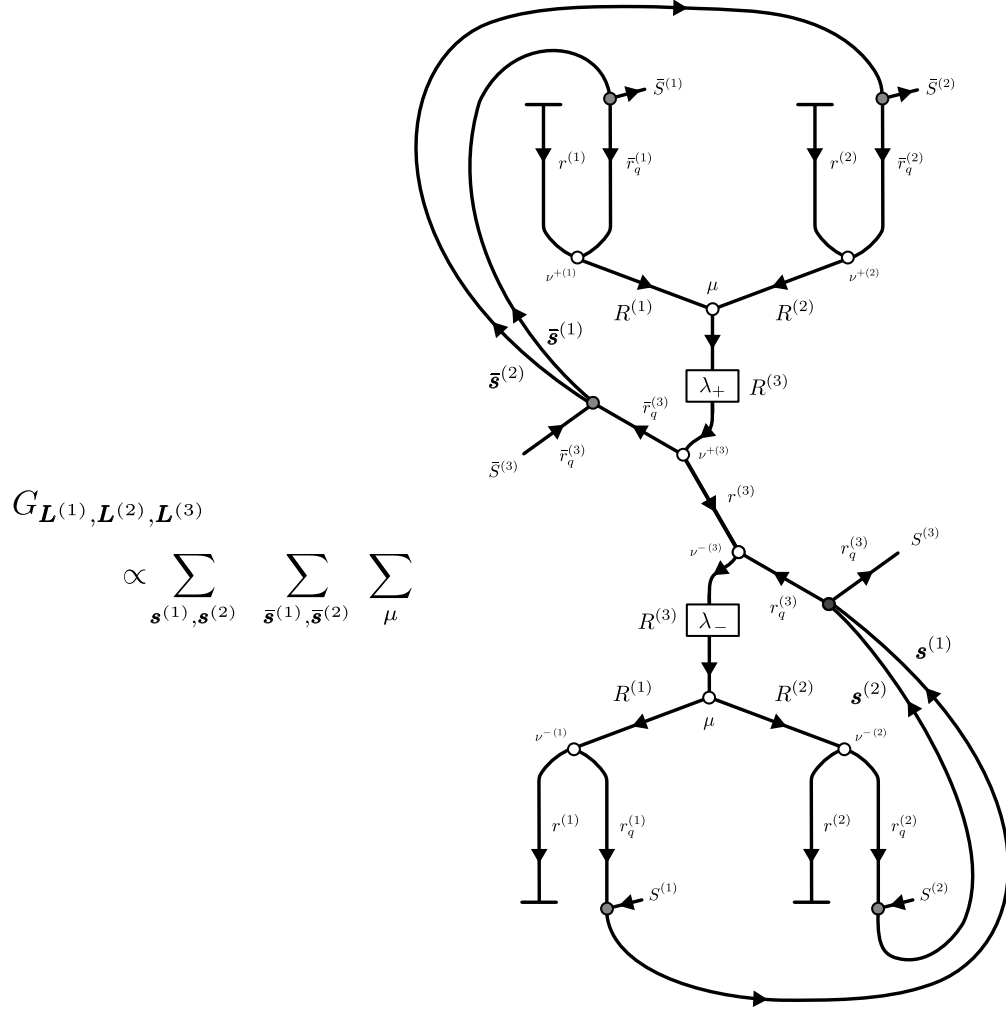

Figure 37: The diagram for the chiral ring structure constants after using the identity (A.3.14). The horizontal bars are to be identified.

Here we can see the relevance of the permutations λ_- and λ_+ , which were previously obtained in the explicit derivation. They allow the fusing of all the state indices of the three disjoint pieces of Fig. 36. This can be understood by looking at Fig. 37. Let us follow the flow at the top of the diagram from $r^{(1)} \otimes \bar{r}_q^{(1)} \otimes r^{(2)} \otimes \bar{r}_q^{(2)}$ to $R^{(3)}$. This corresponds to the embeddings

$$S_{n^{(1)}} \times S_{n_q^{(1)}} \times S_{n^{(2)}} \times S_{n_q^{(2)}} \rightarrow S_{n^{(1)}+n_q^{(1)}} \times S_{n^{(2)}+n_q^{(2)}} \rightarrow S_{n^{(1)}+n^{(2)}+n_q^{(1)}+n_q^{(2)}} \quad (3.4.4)$$

and

$$[n^{(1)}] \sqcup [n_q^{(1)}] \sqcup [n^{(2)}] \sqcup [n_q^{(2)}] \rightarrow [n^{(1)} + n_q^{(1)}] \sqcup [n^{(2)} + n_q^{(2)}] \rightarrow [n^{(1)} + n_q^{(1)} + n^{(2)} + n_q^{(2)}] \quad (3.4.5)$$

The second embedding corresponds to the branching coefficient labelled by μ . In the branching *after* the λ_+ permutation, $R^{(3)}$ splits into $r^{(3)}$ and $r_q^{(3)}$. The relevant embedding is now

$$[n^{(1)} + n^{(2)}] \sqcup [n_q^{(1)} + n_q^{(2)}] \rightarrow [n^{(1)} + n_q^{(1)} + n^{(2)} + n_q^{(2)}] \quad (3.4.6)$$

which comes naturally from the construction of $\mathcal{O}(\mathbf{L}_3)$. The purpose of λ_+ is to allow the transition from (3.4.5) to (3.4.6). A similar (but reversed) role is played by the permutation λ_- .

Now we use the relation in Fig. 45 to separate the edges corresponding to the quark (and antiquark) fields from the rest of the diagram. We thus obtain Fig. 38.

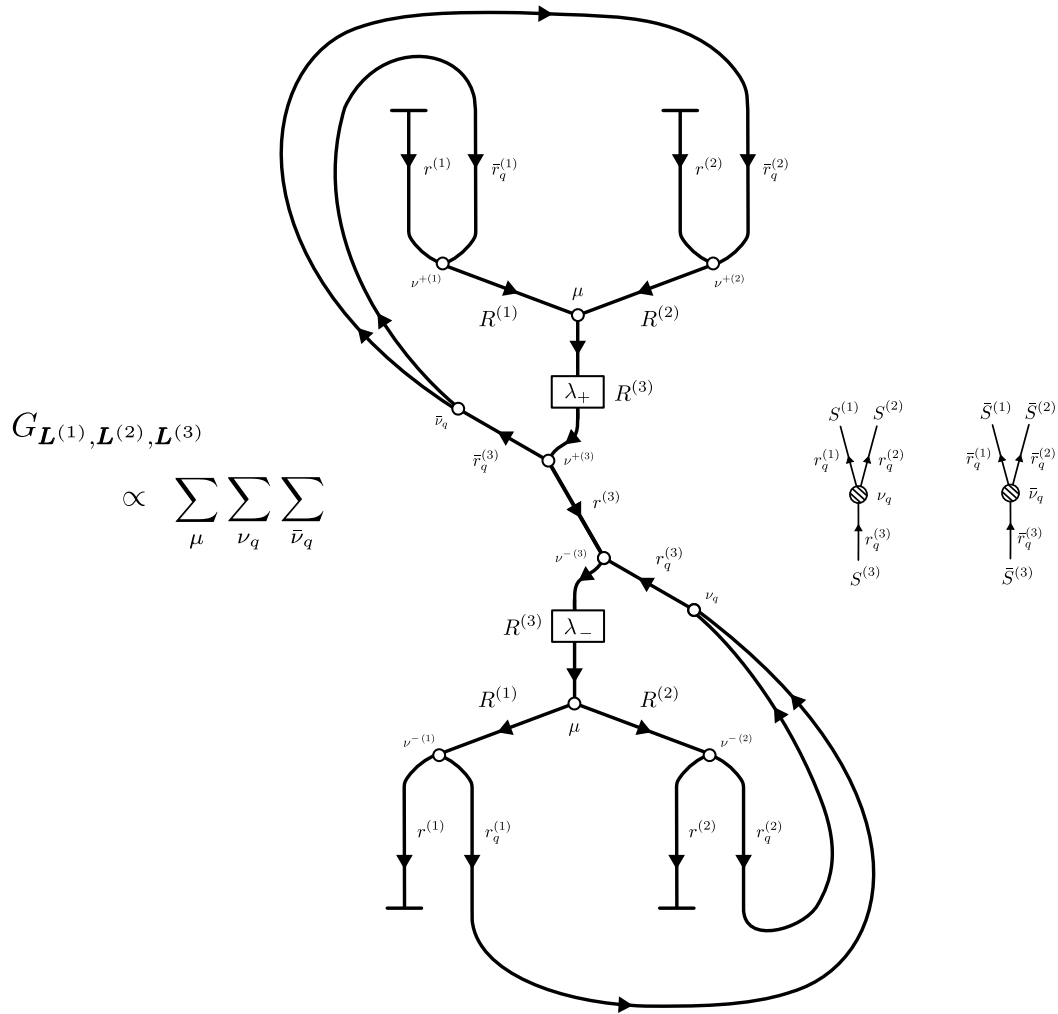

Figure 38: The outcome of inserting the identity described by Fig. 45 into Fig. 37. The horizontal bars are to be identified.

The last step is to separate all the edges connected to the negative node of the split-node from all the edges connected to its positive node. As explained in the derivation above, this operation is achieved through the identity (A.3.43), which in this example takes the form depicted in Fig. 39.

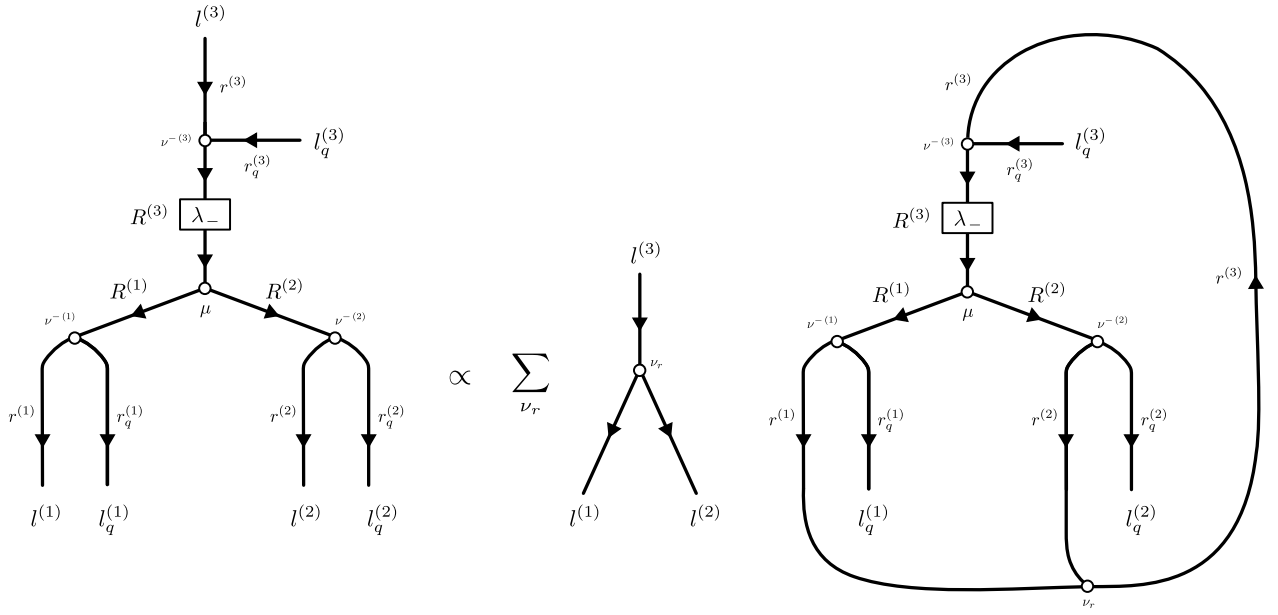

Figure 39: Diagrammatic description of eq. (A.3.43) for the $\mathcal{N} = 2$ SQCD example.

Once this diagrammatic relation has been inserted into Fig. 38, we straightforwardly obtain the final diagram for the chiral ring structure constants for an $\mathcal{N} = 2$ SQCD, depicted in Fig. 33.

3.5 An example: quiver restricted Schur polynomials for an $\mathcal{N} = 2$ SQCD

We will now present some explicit examples of quiver Schurs for an $\mathcal{N} = 2$ SQCD, whose $\mathcal{N} = 1$ quiver is depicted in Fig. 20. We will begin by listing all the matrix invariants in the permutation basis (3.1.12) that it is possible to build using a fixed amount \vec{n} of fundamental fields. We will then Fourier transform these operators to the quiver Schurs basis using (3.2.19). The set of representation theory labels needed to identify any matrix invariant in an $\mathcal{N} = 2$ SQCD has been explicitly given in (3.4.3). In the following we will continue to use such a convention.

The permutation basis is generated by

$$\mathcal{O}(\vec{n}, \vec{s}, \sigma) = (\phi^{\otimes n})_J^I \otimes (Q^{\otimes n_Q})_{\mathbf{s}}^{I_Q} \otimes (\bar{Q}^{\otimes \bar{n}_Q})_{J_Q}^{\bar{\mathbf{s}}} (\sigma)_{I \times I_Q}^{J \times J_Q} \quad (3.5.1)$$

where $\vec{n} = \{n, n_Q, \bar{n}_Q\}$ specifies the field content of the operator \mathcal{O} , and $\vec{s} = (\mathbf{s}, \bar{\mathbf{s}})$. As we previously stated, we construct the quiver Schurs $\mathcal{O}(\mathbf{L})$ by using the Fourier transform (3.2.19):

$$\mathcal{O}(\mathbf{L}) = \sum_{\sigma, \vec{s}} \chi(\mathbf{L}, \vec{s}, \sigma) \mathcal{O}(\vec{n}, \vec{s}, \sigma) \quad (3.5.2)$$

where $\mathbf{L} = \{R, r, r_q, S, \bar{r}_q, \bar{S}, \nu^+, \nu^-\}$ has been defined in eq. (3.4.3). In this formula $\chi(\mathbf{L}, \vec{s}, \sigma)$

is the $\mathcal{N} = 2$ SQCD quiver character, which reads

$$\chi(\mathbf{L}, \vec{s}, \sigma) = c_{\mathbf{L}} D_{i,j}^R(\sigma) \left\{ B_{j \rightarrow l,p}^{R \rightarrow r, r_q; \nu^-} C_{\mathbf{s}}^{r_q, S, p} \right\} \left\{ B_{i \rightarrow l,t}^{R \rightarrow r, \bar{r}_q; \nu^+} C_{\vec{\bar{s}}}^{\bar{r}_q, \bar{S}, t} \right\} \quad (3.5.3)$$

Figure 40 shows the diagram for this quantity.

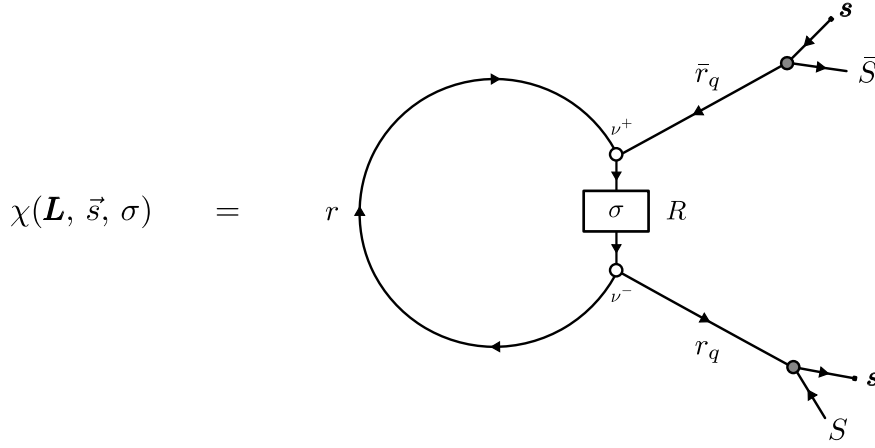

Figure 40: Diagram for the $\mathcal{N} = 2$ SQCD quiver character, corresponding to eq. (3.5.3).

We now focus on some fixed values of \vec{n} .

- $\vec{n} = (2, 1, 1)$ **field content**

We start by listing the Fourier transformed holomorphic GIOs (3.2.19) that we can build with the set of fields $\{\phi, \bar{\phi}, Q, \bar{Q}\}$, that is with the choice $\vec{n} = (2, 1, 1)$. In the permutation basis, these operators read

$$\begin{aligned} \mathcal{O}(\vec{n}, s, \bar{s}, (1)) &= (\phi)(\phi)(\bar{Q}Q)_{\bar{s}}, & \mathcal{O}(\vec{n}, s, \bar{s}, (12)) &= (\phi\phi)(\bar{Q}Q)_{\bar{s}}, \\ \mathcal{O}(\vec{n}, s, \bar{s}, (13)) &= (\phi)(\bar{Q}\phi Q)_{\bar{s}}, & \mathcal{O}(\vec{n}, s, \bar{s}, (23)) &= (\phi)(\bar{Q}\phi Q)_{\bar{s}}, \\ \mathcal{O}(\vec{n}, s, \bar{s}, (123)) &= (\bar{Q}\phi\phi Q)_{\bar{s}}, & \mathcal{O}(\vec{n}, s, \bar{s}, (132)) &= (\bar{Q}\phi\phi Q)_{\bar{s}} \end{aligned} \quad (3.5.4)$$

where the round brackets denote $U(N)$ indices contraction. Notice that in this case $\vec{s} = (s, \bar{s})$. We will now construct the Fourier transformed operators. For this field content we do not have any branching multiplicity ν^+, ν^- : we can drop them from the set of labels \mathbf{L} , which now reads $\mathbf{L} = \{R, r, r_q, S, \bar{r}_q, \bar{S}\}$. We then look for the operators $\mathcal{O}(\mathbf{L}_i)$, $i = 1, 2, 3, 4$, where

$$\begin{aligned} \mathbf{L}_1 &= \{\square\square\square, \square\square, \square, S, \bar{\square}, \bar{S}\}, & \mathbf{L}_2 &= \left\{ \begin{array}{|c|} \hline \square \\ \hline \square \\ \hline \end{array}, \square, \square, S, \bar{\square}, \bar{S} \right\}, \\ \mathbf{L}_3 &= \left\{ \begin{array}{|c|} \hline \square \\ \hline \square \\ \hline \end{array}, \square\square, \square, S, \bar{\square}, \bar{S} \right\}, & \mathbf{L}_4 &= \left\{ \begin{array}{|c|} \hline \square \\ \hline \square \\ \hline \end{array}, \square, \square, S, \bar{\square}, \bar{S} \right\} \end{aligned} \quad (3.5.5)$$

We left the states S, \bar{S} of the fundamental and antifundamental representation of $SU(F)$ implicit.

We first notice that, having one quark-antiquark pair only, the Clebsch-Gordan coefficients simplify as

$$C_{\mathbf{s}}^{r_q, S, p} = C_{\mathbf{s}}^{\square, S, p} \equiv \delta_{\mathbf{s}}^S, \quad C_{\bar{\mathbf{s}}}^{\bar{r}_q, \bar{S}, t} = C_{\bar{\mathbf{s}}}^{\bar{\square}, \bar{S}, t} \equiv \delta_{\bar{\mathbf{s}}}^{\bar{S}} \quad (3.5.6)$$

We can then easily compute $\chi(\mathbf{L}_1)$ and $\chi(\mathbf{L}_2)$. Both the symmetric group representation branching $\square\square\square \rightarrow \square\square \otimes \square$ and $\square \rightarrow \square \otimes \square$ describe the branching of a 1-dimensional space into itself: as such their associate branching coefficients equal 1 identically. On the other hand, $D^{\square\square}(\sigma) = 1 \forall \sigma$ and $D^{\square}(\sigma) = \text{sign}(\sigma)$. We then have

$$\chi(\mathbf{L}_1, s, \bar{s}, \sigma) = \frac{1}{\sqrt{3!}} \delta_s^S \delta_{\bar{s}}^{\bar{S}}, \quad \chi(\mathbf{L}_2, s, \bar{s}, \sigma) = \frac{1}{\sqrt{3!}} \text{sign}(\sigma) \delta_s^S \delta_{\bar{s}}^{\bar{S}} \quad (3.5.7)$$

The S_3 irrep $\square\square$ is two dimensional, and we work in an orthonormal basis $\{e_1, e_2\}$ in which it reads⁴

$$\begin{aligned} D^{\square\square}((1)) &= \begin{pmatrix} 1 & 0 \\ 0 & 1 \end{pmatrix}, & D^{\square\square}((12)) &= \begin{pmatrix} 1 & 0 \\ 0 & -1 \end{pmatrix}, & D^{\square\square}((13)) &= \begin{pmatrix} -\frac{1}{2} & -\frac{\sqrt{3}}{2} \\ -\frac{\sqrt{3}}{2} & \frac{1}{2} \end{pmatrix} \\ D^{\square\square}((23)) &= \begin{pmatrix} -\frac{1}{2} & \frac{\sqrt{3}}{2} \\ \frac{\sqrt{3}}{2} & \frac{1}{2} \end{pmatrix}, & D^{\square\square}((123)) &= \begin{pmatrix} -\frac{1}{2} & -\frac{\sqrt{3}}{2} \\ \frac{\sqrt{3}}{2} & -\frac{1}{2} \end{pmatrix}, & D^{\square\square}((132)) &= \begin{pmatrix} -\frac{1}{2} & \frac{\sqrt{3}}{2} \\ -\frac{\sqrt{3}}{2} & -\frac{1}{2} \end{pmatrix} \end{aligned} \quad (3.5.8)$$

If we restrict S_3 to $S_2 \times S_1$, the $\square\square$ reduces as

$$\square\square \Big|_{S_2 \times S_1} = \square\square \otimes \square \oplus \square \otimes \square \quad (3.5.9)$$

The restricted group $S_3|_{S_2 \times S_1}$ only contains two elements: $S_3|_{S_2 \times S_1} = \{(1), (12)\}$. The branching coefficients for this restriction are the matrix elements of the orthogonal operator B such that

$$B^{-1} D^{\square\square}((12)) B = D^{\square\square}((12)) \otimes D^{\square}((1)) \oplus D^{\square}((12)) \otimes D^{\square}((1)) = \text{diag}(1, -1) \quad (3.5.10)$$

With our basis choice for $\square\square$ such a decomposition is already manifest, as it is clear from the matrix expression of the identity element and the (12) transposition in (3.5.8). Therefore, for this particular configuration, B is just the two dimensional identity matrix: $B = 1_2$. If we label f_1 the only state in the $\square\square$ of S_2 and f_2 the only state in the \square of S_2 , the branching coefficients read

$$B_{j \rightarrow 1,1}^{\square\square \rightarrow \square\square, \square} = (e_j, f_1) = \delta_{j,1}, \quad B_{j \rightarrow 1,1}^{\square\square \rightarrow \square, \square} = (e_j, f_2) = \delta_{j,2} \quad (3.5.11)$$

⁴Note that this is *not* the convention used in the SageMath software.

Inserting this result in (3.5.3) we obtain an expression for $\chi(\mathbf{L}_3)$ and $\chi(\mathbf{L}_4)$:

$$\begin{aligned}\chi(\mathbf{L}_3, s, \bar{s}, \sigma) &= \frac{1}{\sqrt{3}} \text{Tr} [D^{\mathbb{P}}(\sigma) P^{\mathbb{P} \rightarrow \square, \square}] \delta_s^S \delta_{\bar{s}}^{\bar{S}}, \\ \chi(\mathbf{L}_4, s, \bar{s}, \sigma) &= \frac{1}{\sqrt{3}} \text{Tr} [D^{\mathbb{P}}(\sigma) P^{\mathbb{P} \rightarrow \mathbb{B}, \square}] \delta_s^S \delta_{\bar{s}}^{\bar{S}}\end{aligned}\quad (3.5.12)$$

Here $P^{\mathbb{P} \rightarrow \square, \square}$ and $P^{\mathbb{P} \rightarrow \mathbb{B}, \square}$ are the projection operators of the \square of S_3 on the $\square \otimes \square$ of $S_2 \times S_1$ and the \square of S_3 on the $\square \otimes \square$ of $S_2 \times S_1$:

$$P^{\mathbb{P} \rightarrow \square, \square} = \begin{pmatrix} 1 & 0 \\ 0 & 0 \end{pmatrix}, \quad P^{\mathbb{P} \rightarrow \mathbb{B}, \square} = \begin{pmatrix} 0 & 0 \\ 0 & 1 \end{pmatrix}\quad (3.5.13)$$

We are now ready to write down the Fourier transformed operators. Using the definition (3.5.2) and the results (3.5.7) and (3.5.12), we find that

$$\begin{aligned}\mathcal{O}(\mathbf{L}_1) &= \frac{1}{\sqrt{3!}} \left((\phi)(\phi)(\bar{Q}Q)_S^{\bar{S}} + (\phi\phi)(\bar{Q}Q)_S^{\bar{S}} + 2(\phi)(\bar{Q}\phi Q)_S^{\bar{S}} + 2(\bar{Q}\phi\phi Q)_S^{\bar{S}} \right), \\ \mathcal{O}(\mathbf{L}_2) &= \frac{1}{\sqrt{3!}} \left((\phi)(\phi)(\bar{Q}Q)_S^{\bar{S}} - (\phi\phi)(\bar{Q}Q)_S^{\bar{S}} - 2(\phi)(\bar{Q}\phi Q)_S^{\bar{S}} + 2(\bar{Q}\phi\phi Q)_S^{\bar{S}} \right), \\ \mathcal{O}(\mathbf{L}_3) &= \frac{1}{\sqrt{3}} \left((\phi)(\phi)(\bar{Q}Q)_S^{\bar{S}} + (\phi\phi)(\bar{Q}Q)_S^{\bar{S}} - (\phi)(\bar{Q}\phi Q)_S^{\bar{S}} - (\bar{Q}\phi\phi Q)_S^{\bar{S}} \right), \\ \mathcal{O}(\mathbf{L}_4) &= \frac{1}{\sqrt{3}} \left((\phi)(\phi)(\bar{Q}Q)_S^{\bar{S}} - (\phi\phi)(\bar{Q}Q)_S^{\bar{S}} + (\phi)(\bar{Q}\phi Q)_S^{\bar{S}} - (\bar{Q}\phi\phi Q)_S^{\bar{S}} \right)\end{aligned}\quad (3.5.14)$$

We can now perform some checks on this result. First of all, we expect to see the finite N constraints to manifest themselves if the gauge group of the theory is either $N = 1$ or $N = 2$. In the former case, only $\mathcal{O}(\mathbf{L}_1)$ should remain, and it is in fact easy to see that for $N = 1$ all the other operators are identically zero. For the latter case, we expect $\mathcal{O}(\mathbf{L}_2)$ to vanish, as $l(\square) > 2$, and as such it violates the finite N constraints. Indeed, using the identity $\phi^2 = (\phi)\phi - \det(\phi)1_2$, which follows from the Cayley-Hamilton theorem, one can verify that $\mathcal{O}(\mathbf{L}_2) = 0$ for a $U(2)$ gauge group.

We also expect these operators to be orthogonal in the free field metric. According to eq. (3.3.12), the two point function in the permutation basis is simply

$$\left\langle \mathcal{O}(\vec{n}, s, \bar{s}, \sigma) \mathcal{O}^\dagger(\vec{n}, t, \bar{t}, \tau) \right\rangle = \delta_{s,t} \delta_{\bar{s}, \bar{t}} \sum_{\eta \in S_2} N^{C[(\eta \times 1) \sigma (\eta \times 1)^{-1} \tau^{-1}]}, \quad \vec{n} = (2, 1, 1) \quad (3.5.15)$$

where $C[\sigma]$ is the number of cycles in the permutation σ . With this equation we can check that

all the states in (3.5.14) are orthogonal, and that

$$\begin{aligned} \langle \mathcal{O}(\mathbf{L}_1) \mathcal{O}^\dagger(\mathbf{L}_1) \rangle &= 2N(N+1)(N+2), & \langle \mathcal{O}(\mathbf{L}_2) \mathcal{O}^\dagger(\mathbf{L}_2) \rangle &= 2N(N-1)(N-2), \\ \langle \mathcal{O}(\mathbf{L}_3) \mathcal{O}^\dagger(\mathbf{L}_3) \rangle &= 2N(N^2-1), & \langle \mathcal{O}(\mathbf{L}_4) \mathcal{O}^\dagger(\mathbf{L}_4) \rangle &= 2N(N^2-1) \end{aligned} \quad (3.5.16)$$

in agreement with (3.3.1).

- $\vec{n} = (1, 2, 2)$ **field content**

We now consider a different field content, that is $\{\phi, Q, Q, \bar{Q}, \bar{Q}\}$. This choice corresponds to $\vec{n} = (1, 2, 2)$. In the permutation basis, the GIOs that we can form with these fields are

$$\begin{aligned} \mathcal{O}(\vec{n}, \vec{s}, (1)) &= (\phi) (\bar{Q}Q)_{s_1}^{\bar{s}_1} (\bar{Q}Q)_{s_2}^{\bar{s}_2}, & \mathcal{O}(\vec{n}, \vec{s}, (12)) &= (\bar{Q}\phi Q)_{s_1}^{\bar{s}_1} (\bar{Q}Q)_{s_2}^{\bar{s}_2}, \\ \mathcal{O}(\vec{n}, \vec{s}, (13)) &= (\bar{Q}\phi Q)_{s_2}^{\bar{s}_2} (\bar{Q}Q)_{s_1}^{\bar{s}_1}, & \mathcal{O}(\vec{n}, \vec{s}, (23)) &= (\phi) (\bar{Q}Q)_{s_2}^{\bar{s}_1} (\bar{Q}Q)_{s_1}^{\bar{s}_2}, \\ \mathcal{O}(\vec{n}, \vec{s}, (123)) &= (\bar{Q}\phi Q)_{s_1}^{\bar{s}_2} (\bar{Q}Q)_{s_2}^{\bar{s}_1}, & \mathcal{O}(\vec{n}, \vec{s}, (132)) &= (\bar{Q}\phi Q)_{s_2}^{\bar{s}_1} (\bar{Q}Q)_{s_1}^{\bar{s}_2} \end{aligned} \quad (3.5.17)$$

Here $\vec{s} = (s_1, s_2, \bar{s}_1, \bar{s}_2)$, and the round brackets denote $U(N)$ indices contraction.

Let us now construct the Fourier transformed operators. As in the previous example, for this fields content we do not have any branching multiplicity ν^+ , ν^- , so that we will drop them from the set of labels in \mathbf{L} . We will now write the expression for the six operators $\mathcal{O}(\mathbf{L}_i)$, $i = 1, 2, \dots, 6$, with

$$\begin{aligned} \mathbf{L}_1 &= \{\square\square\square, \square, \square\square, S, \overline{\square\square}, \bar{S}\}, & \mathbf{L}_2 &= \left\{ \begin{array}{|c|} \hline \square \\ \hline \square \\ \hline \end{array}, \square, \begin{array}{|c|} \hline \square \\ \hline \end{array}, S, \overline{\begin{array}{|c|} \hline \square \\ \hline \end{array}}, \bar{S} \right\}, \\ \mathbf{L}_3 &= \left\{ \begin{array}{|c|} \hline \square \\ \hline \square \\ \hline \end{array}, \square, \square\square, S, \overline{\square\square}, \bar{S} \right\}, & \mathbf{L}_4 &= \left\{ \begin{array}{|c|} \hline \square \\ \hline \square \\ \hline \end{array}, \square, \begin{array}{|c|} \hline \square \\ \hline \end{array}, S, \overline{\begin{array}{|c|} \hline \square \\ \hline \end{array}}, \bar{S} \right\}, \\ \mathbf{L}_5 &= \left\{ \begin{array}{|c|} \hline \square \\ \hline \square \\ \hline \end{array}, \square, \square\square, S, \overline{\begin{array}{|c|} \hline \square \\ \hline \end{array}}, \bar{S} \right\}, & \mathbf{L}_6 &= \left\{ \begin{array}{|c|} \hline \square \\ \hline \square \\ \hline \end{array}, \square, \begin{array}{|c|} \hline \square \\ \hline \end{array}, S, \overline{\square\square}, \bar{S} \right\} \end{aligned} \quad (3.5.18)$$

As in the previous example, we leave the $SU(F)$ states S, \bar{S} implicit.

The symmetric branching group coefficients are similar to the ones already introduced in the previous example. Both the branchings $\square\square\square \rightarrow \square \oplus \square\square$ and $\begin{array}{|c|} \hline \square \\ \hline \square \\ \hline \end{array} \rightarrow \square \oplus \begin{array}{|c|} \hline \square \\ \hline \end{array}$ are trivial, as they correspond to a branching of a 1-dimensional space into itself. These branching coefficients are therefore equal to 1 identically:

$$B_{1 \rightarrow 1,1}^{\square\square\square \rightarrow \square, \square\square} \equiv 1, \quad B_{1 \rightarrow 1,1}^{\begin{array}{|c|} \hline \square \\ \hline \square \\ \hline \end{array} \rightarrow \square, \begin{array}{|c|} \hline \square \\ \hline \end{array}} \equiv 1 \quad (3.5.19)$$

We now turn to the reduction

$$\begin{array}{|c|} \hline \square \\ \hline \square \\ \hline \end{array} \Big|_{S_1 \times S_2} = \square \otimes \square\square \oplus \square \otimes \begin{array}{|c|} \hline \square \\ \hline \end{array} \quad (3.5.20)$$

As in the previous example, the group $S_3|_{S_1 \times S_2}$ only contains two elements, but this time they are $S_3|_{S_1 \times S_2} = \{(1), (23)\}$. This is because the $(1) \times (12) \in S_1 \times S_2$ has to be embedded into

S_3 , where it corresponds to the transposition (23). The branching coefficients for the reduction in (3.5.20) will be the matrix elements of the orthogonal operator B such that

$$B^{-1}D^{\mathbb{P}}((23))B = D^{\circ}((1)) \otimes D^{\square}((12)) \oplus D^{\circ}((1)) \otimes D^{\mathbb{P}}((12)) = \text{diag}(1, -1) \quad (3.5.21)$$

We equip the $\square\square$ of S_3 with a basis $\{e_1, e_2\}$, in which the representation takes the explicit form (3.5.8). We then choose f_1 and f_2 to be the basis vectors of the $\square\square$ and the \square of S_2 respectively. In this basis the orthogonal matrix B must then take the form

$$B = \begin{pmatrix} \frac{1}{2} & -\frac{\sqrt{3}}{2} \\ \frac{\sqrt{3}}{2} & \frac{1}{2} \end{pmatrix} \quad (3.5.22)$$

We then have, by construction, $Be_1 = f_1$ and $Be_2 = f_2$. The branching coefficients for the reduction (3.5.20) then read

$$\begin{aligned} B_{1 \rightarrow 1,1}^{\square \rightarrow \square, \square} &= (e_1, f_1) = \frac{1}{2}, & B_{1 \rightarrow 1,1}^{\square \rightarrow \square, \mathbb{P}} &= (e_1, f_2) = -\frac{\sqrt{3}}{2}, \\ B_{2 \rightarrow 1,1}^{\square \rightarrow \square, \square} &= (e_2, f_1) = \frac{\sqrt{3}}{2}, & B_{2 \rightarrow 1,1}^{\square \rightarrow \square, \mathbb{P}} &= (e_2, f_2) = \frac{1}{2} \end{aligned} \quad (3.5.23)$$

It is useful to define the orthogonal projectors

$$P_{i,j}^{\square \rightarrow \square, \square} = B_{i \rightarrow 1,1}^{\square \rightarrow \square, \square} B_{j \rightarrow 1,1}^{\square \rightarrow \square, \square}, \quad P_{i,j}^{\square \rightarrow \square, \mathbb{P}} = B_{i \rightarrow 1,1}^{\square \rightarrow \square, \mathbb{P}} B_{j \rightarrow 1,1}^{\square \rightarrow \square, \mathbb{P}} \quad (3.5.24)$$

projecting the $\square\square$ of S_3 on the $\square \otimes \square\square$ and on the $\square \otimes \square$ of $S_1 \times S_2$ respectively. We also define the linear operator T through its matrix elements as

$$T_{i,j} = B_{i \rightarrow 1,1}^{\square \rightarrow \square, \square} B_{j \rightarrow 1,1}^{\square \rightarrow \square, \mathbb{P}} \quad (3.5.25)$$

Explicitly, these matrices read

$$P^{\square \rightarrow \square, \square} = \frac{1}{4} \begin{pmatrix} 1 & \sqrt{3} \\ \sqrt{3} & 3 \end{pmatrix}, \quad P^{\square \rightarrow \square, \mathbb{P}} = \frac{1}{4} \begin{pmatrix} 3 & -\sqrt{3} \\ -\sqrt{3} & 1 \end{pmatrix}, \quad T = \frac{1}{4} \begin{pmatrix} -\sqrt{3} & 1 \\ -3 & \sqrt{3} \end{pmatrix} \quad (3.5.26)$$

We will use these quantities to compactly write the quiver characters.

We now turn to the Clebsch-Gordan coefficients, $C_{s_1, s_2}^{r_q, S, p}$ and $C_{\bar{s}_1, \bar{s}_2}^{\bar{r}_q, \bar{S}, t}$, where r_q and \bar{r}_q are both either $\square\square$ or \square . First of all notice that we can drop the symmetric group state labels p and t , because all the irreducible representation of S_2 are 1-dimensional. Let us call V_F the the fundamental representation of $SU(F)$, and let us choose an orthonormal basis e_i , $i = 1, 2, \dots, F$. Consider now the $V_F \otimes V_F$ vector space, equipped with the induced basis $\{e_{i,j} = e_i \otimes e_j\}_{ij}$. The $\square\square$ of $SU(F)$ is spanned by every symmetric permutation of the $e_{i,j} = e_i \otimes e_j$ basis vectors of $V_F \otimes V_F$. We can label an orthonormal basis for this representation with the notation $\boxed{i \ j}$,

where

$$\boxed{i \mid i} = e_i \otimes e_i, \quad (3.5.27a)$$

$$\boxed{i \mid j} = \frac{1}{\sqrt{2}}(e_i \otimes e_j + e_j \otimes e_i), \quad i \neq j \quad (3.5.27b)$$

On the other hand, the \square of $SU(F)$ is spanned by every antisymmetric permutation of the $e_{i,j} = e_i \otimes e_j$ basis vectors of $V_F \otimes V_F$. We can label an orthonormal basis for this representation with the notation $\begin{smallmatrix} i \\ j \end{smallmatrix}$, where

$$\begin{smallmatrix} i \\ j \end{smallmatrix} = \frac{1}{\sqrt{2}}(e_i \otimes e_j - e_j \otimes e_i) \quad (3.5.28)$$

We can therefore easily compute the Clebsch-Gordan coefficients (3.2.18). To optimise the notation, we use the Young tableaux $\boxed{i \mid j}$ and $\begin{smallmatrix} i \\ j \end{smallmatrix}$ to label both the $SU(F)$ representations and their states. The Clebsch-Gordan coefficients then read

$$\begin{aligned} C_{k,l}^{\boxed{i \mid i}} &= (e_{k,l}, \boxed{i \mid i}) = (e_k \otimes e_l, e_i \otimes e_i) = \delta_{k,i} \delta_{l,i}, \\ C_{k,l}^{\boxed{i \mid j}} &= (e_{k,l}, \boxed{i \mid j}) = \frac{1}{\sqrt{2}}(e_k \otimes e_l, e_i \otimes e_j + e_j \otimes e_i) = \frac{1}{\sqrt{2}}(\delta_{k,i} \delta_{l,j} + \delta_{k,j} \delta_{l,i}), \quad i \neq j, \\ C_{k,l}^{\begin{smallmatrix} i \\ j \end{smallmatrix}} &= (e_{k,l}, \begin{smallmatrix} i \\ j \end{smallmatrix}) = \frac{1}{\sqrt{2}}(e_k \otimes e_l, e_i \otimes e_j - e_j \otimes e_i) = \frac{1}{\sqrt{2}}(\delta_{k,i} \delta_{l,j} - \delta_{k,j} \delta_{l,i}) \end{aligned} \quad (3.5.29)$$

A similar approach can be used to derive the Clebsch-Gordan coefficients for the decomposition of the $\bar{V}_F \otimes \bar{V}_F$ representation of $SU(F)$, which gives similar results to the ones in (3.5.29).

We can now write the quiver characters for the six states (3.5.18). Denoting the generic flavour state $|S\rangle \in V_{r_q}^{SU(F)}$ as in (3.5.27) for $r_q = \square\square$ and as in (3.5.28) for $r_q = \square$ (and similarly for $|\bar{S}\rangle \in V_{\bar{r}_q}^{SU(F)}$), the labels in (3.5.18) read now

$$\begin{aligned} \mathbf{L}_1 &= \{\square\square\square, \square, \boxed{i \mid j}, \overline{p \mid q}\}, & \mathbf{L}_2 &= \left\{ \begin{smallmatrix} i \\ j \end{smallmatrix}, \square, \begin{smallmatrix} i \\ j \end{smallmatrix}, \overline{p \mid q} \right\}, \\ \mathbf{L}_3 &= \left\{ \begin{smallmatrix} i \\ j \end{smallmatrix}, \square, \boxed{i \mid j}, \overline{p \mid q} \right\}, & \mathbf{L}_4 &= \left\{ \begin{smallmatrix} i \\ j \end{smallmatrix}, \square, \begin{smallmatrix} i \\ j \end{smallmatrix}, \overline{p \mid q} \right\}, \\ \mathbf{L}_5 &= \left\{ \begin{smallmatrix} i \\ j \end{smallmatrix}, \square, \boxed{i \mid j}, \overline{p \mid q} \right\}, & \mathbf{L}_6 &= \left\{ \begin{smallmatrix} i \\ j \end{smallmatrix}, \square, \begin{smallmatrix} i \\ j \end{smallmatrix}, \overline{p \mid q} \right\} \end{aligned} \quad (3.5.30)$$

The quiver characters are

$$\begin{aligned}
 \chi(\mathbf{L}_1, \vec{s}, \sigma) &= \frac{1}{\sqrt{3!}} C_{s_1, s_2}^{\boxed{i|j}} C_{\bar{s}_1, \bar{s}_2}^{\overline{\boxed{p|q}}}, \\
 \chi(\mathbf{L}_2, \vec{s}, \sigma) &= \frac{1}{\sqrt{3!}} \text{sign}(\sigma) C_{s_1, s_2}^{\boxed{i|j}} C_{\bar{s}_1, \bar{s}_2}^{\overline{\boxed{p|q}}}, \\
 \chi(\mathbf{L}_3, \vec{s}, \sigma) &= \frac{1}{\sqrt{3}} \text{Tr} [D^{\boxplus}(\sigma) P^{\boxplus \rightarrow \square, \square}] C_{s_1, s_2}^{\boxed{i|j}} C_{\bar{s}_1, \bar{s}_2}^{\overline{\boxed{p|q}}}, \\
 \chi(\mathbf{L}_4, \vec{s}, \sigma) &= \frac{1}{\sqrt{3}} \text{Tr} [D^{\boxplus}(\sigma) P^{\boxplus \rightarrow \square, \boxplus}] C_{s_1, s_2}^{\boxed{i|j}} C_{\bar{s}_1, \bar{s}_2}^{\overline{\boxed{p|q}}}, \\
 \chi(\mathbf{L}_5, \vec{s}, \sigma) &= \frac{1}{\sqrt{3}} \text{Tr} [D^{\boxplus}(\sigma) T] C_{s_1, s_2}^{\boxed{i|j}} C_{\bar{s}_1, \bar{s}_2}^{\overline{\boxed{p|q}}}, \\
 \chi(\mathbf{L}_6, \vec{s}, \sigma) &= \frac{1}{\sqrt{3}} \text{Tr} [D^{\boxplus}(\sigma) T^t] C_{s_1, s_2}^{\boxed{i|j}} C_{\bar{s}_1, \bar{s}_2}^{\overline{\boxed{p|q}}} \tag{3.5.31}
 \end{aligned}$$

where T^t denotes the transpose of the matrix T , defined in (3.5.26).

Defining the normalisation constants

$$f_{i,j} = \begin{cases} 1 & \text{if } i \neq j \\ \frac{1}{\sqrt{2}} & \text{if } i = j \end{cases} \tag{3.5.32}$$

which keeps track of the different normalisation of the Clebsch-Gordan coefficients (3.5.27a) and (3.5.27b), the Fourier transformed operators take the explicit form

$$\begin{aligned}
 \mathcal{O}(\mathbf{L}_1) &= \frac{f_{i,j} f_{\bar{p}, \bar{q}}}{\sqrt{3!}} \left((\phi) (\bar{Q}Q)_{(i)}^{(\bar{p})} (\bar{Q}Q)_{(j)}^{(\bar{q})} + 2(\bar{Q}\phi Q)_{(i)}^{(\bar{p})} (\bar{Q}Q)_{(j)}^{(\bar{q})} \right), \\
 \mathcal{O}(\mathbf{L}_2) &= \frac{1}{\sqrt{3!}} \left((\phi) (\bar{Q}Q)_{[i]}^{[\bar{p}]} (\bar{Q}Q)_{[j]}^{[\bar{q}]} - 2(\bar{Q}\phi Q)_{[i]}^{[\bar{p}]} (\bar{Q}Q)_{[j]}^{[\bar{q}]} \right), \\
 \mathcal{O}(\mathbf{L}_3) &= \frac{f_{i,j} f_{\bar{p}, \bar{q}}}{\sqrt{3}} \left((\phi) (\bar{Q}Q)_{(i)}^{(\bar{p})} (\bar{Q}Q)_{(j)}^{(\bar{q})} - (\bar{Q}\phi Q)_{(i)}^{(\bar{p})} (\bar{Q}Q)_{(j)}^{(\bar{q})} \right), \\
 \mathcal{O}(\mathbf{L}_4) &= \frac{1}{\sqrt{3}} \left((\phi) (\bar{Q}Q)_{[i]}^{[\bar{p}]} (\bar{Q}Q)_{[j]}^{[\bar{q}]} + (\bar{Q}\phi Q)_{[i]}^{[\bar{p}]} (\bar{Q}Q)_{[j]}^{[\bar{q}]} \right), \\
 \mathcal{O}(\mathbf{L}_5) &= -f_{i,j} (\bar{Q}\phi Q)_{(i)}^{(\bar{p})} (\bar{Q}Q)_{(j)}^{(\bar{q})}, \\
 \mathcal{O}(\mathbf{L}_6) &= -f_{\bar{p}, \bar{q}} (\bar{Q}\phi Q)_{[i]}^{[\bar{p}]} (\bar{Q}Q)_{[j]}^{[\bar{q}]} \tag{3.5.33}
 \end{aligned}$$

Round brackets around the flavour indices denotes their symmetrisation, square brackets around them denotes their antisymmetrisation.

As in the previous case, we now run some tests on this result. It is easily seen that if the

rank of the gauge group is $N = 1$, then among these six operators only $\mathcal{O}(\mathbf{L}_1)$ is non-zero, in agreement with our finite N constraints (3.3.3). Moreover, when $N = 2$, by explicitly writing all the components of $\mathcal{O}(\mathbf{L}_2)$ it is possible to check that $\mathcal{O}(\mathbf{L}_2) = 0$. This is a nontrivial result, once again predicted by the finite N constraints. Let us now check the orthogonality of these operators, in the free field metric. For this field content the two point function in the permutation basis, eq. (3.3.12), reads

$$\langle \mathcal{O}(\vec{n}, \vec{s}, \sigma) \mathcal{O}^\dagger(\vec{n}, \vec{t}, \tau) \rangle = \sum_{\rho_1, \rho_2 \in S_2} \delta_{\rho_1(\mathbf{s}), \mathbf{t}} \delta_{\rho_2(\vec{s}), \vec{t}} N^{C[(1 \times \rho_2) \sigma (1 \times \rho_1)^{-1} \tau^{-1}]}, \quad \vec{n} = (1, 2, 2) \quad (3.5.34)$$

As in the previous example, $C[\sigma]$ is the number of cycles in the permutation σ . Using this equation we can verify that the states in (3.5.33) are indeed orthogonal. Similarly, their squared norm are

$$\begin{aligned} \langle \mathcal{O}(\mathbf{L}_1) \mathcal{O}^\dagger(\mathbf{L}_1) \rangle &= 4N(N+1)(N+2), & \langle \mathcal{O}(\mathbf{L}_2) \mathcal{O}^\dagger(\mathbf{L}_2) \rangle &= 4N(N-1)(N-2), \\ \langle \mathcal{O}(\mathbf{L}_3) \mathcal{O}^\dagger(\mathbf{L}_3) \rangle &= 4N(N^2-1), & \langle \mathcal{O}(\mathbf{L}_4) \mathcal{O}^\dagger(\mathbf{L}_4) \rangle &= 4N(N^2-1), \\ \langle \mathcal{O}(\mathbf{L}_5) \mathcal{O}^\dagger(\mathbf{L}_5) \rangle &= 4N(N^2-1), & \langle \mathcal{O}(\mathbf{L}_6) \mathcal{O}^\dagger(\mathbf{L}_6) \rangle &= 4N(N^2-1) \end{aligned} \quad (3.5.35)$$

in agreement with our prediction (3.3.1).

- $\vec{n} = (2, 2, 2)$ field content

Consider now the field content $\{\phi, \phi, Q, Q, \bar{Q}, \bar{Q}\}$, that is $\vec{n} = (2, 2, 2)$. Using the same notation of the previous examples, the quiver Schurs for this subspace can be labelled by the fourteen sets

$$\mathbf{L}_1 = \left\{ \begin{array}{|c|c|c|c|} \hline & & & \\ \hline \end{array}, \begin{array}{|c|c|} \hline & \\ \hline \end{array}, \begin{array}{|c|c|} \hline i & j \\ \hline \end{array}, \begin{array}{|c|c|} \hline \bar{p} & \bar{q} \\ \hline \end{array} \right\}, \quad \mathbf{L}_2 = \left\{ \begin{array}{|c|} \hline \\ \hline \\ \hline \end{array}, \begin{array}{|c|} \hline \\ \hline \end{array}, \begin{array}{|c|} \hline i \\ \hline j \\ \hline \end{array}, \begin{array}{|c|} \hline \bar{p} \\ \hline \bar{q} \\ \hline \end{array} \right\}, \quad (3.5.36)$$

$$\mathbf{L}_3 = \left\{ \begin{array}{|c|c|c|} \hline & & \\ \hline \end{array}, \begin{array}{|c|c|} \hline & \\ \hline \end{array}, \begin{array}{|c|c|} \hline i & j \\ \hline \end{array}, \begin{array}{|c|c|} \hline \bar{p} & \bar{q} \\ \hline \end{array} \right\}, \quad \mathbf{L}_4 = \left\{ \begin{array}{|c|c|c|} \hline & & \\ \hline \end{array}, \begin{array}{|c|} \hline \\ \hline \end{array}, \begin{array}{|c|c|} \hline i & j \\ \hline \end{array}, \begin{array}{|c|c|} \hline \bar{p} & \bar{q} \\ \hline \end{array} \right\}, \quad (3.5.37)$$

$$\mathbf{L}_5 = \left\{ \begin{array}{|c|c|c|} \hline & & \\ \hline \end{array}, \begin{array}{|c|c|} \hline & \\ \hline \end{array}, \begin{array}{|c|} \hline i \\ \hline j \\ \hline \end{array}, \begin{array}{|c|} \hline \bar{p} \\ \hline \bar{q} \\ \hline \end{array} \right\}, \quad \mathbf{L}_6 = \left\{ \begin{array}{|c|c|c|} \hline & & \\ \hline \end{array}, \begin{array}{|c|c|} \hline & \\ \hline \end{array}, \begin{array}{|c|c|} \hline i & j \\ \hline \end{array}, \begin{array}{|c|} \hline \bar{p} \\ \hline \bar{q} \\ \hline \end{array} \right\}, \quad (3.5.38)$$

$$\mathbf{L}_7 = \left\{ \begin{array}{|c|c|c|} \hline & & \\ \hline \end{array}, \begin{array}{|c|c|} \hline & \\ \hline \end{array}, \begin{array}{|c|} \hline i \\ \hline j \\ \hline \end{array}, \begin{array}{|c|c|} \hline \bar{p} & \bar{q} \\ \hline \end{array} \right\}, \quad \mathbf{L}_8 = \left\{ \begin{array}{|c|c|} \hline & \\ \hline \end{array}, \begin{array}{|c|} \hline \\ \hline \end{array}, \begin{array}{|c|} \hline i \\ \hline j \\ \hline \end{array}, \begin{array}{|c|} \hline \bar{p} \\ \hline \bar{q} \\ \hline \end{array} \right\}, \quad (3.5.39)$$

$$\mathbf{L}_9 = \left\{ \begin{array}{|c|c|} \hline & \\ \hline \end{array}, \begin{array}{|c|} \hline \\ \hline \end{array}, \begin{array}{|c|c|} \hline i & j \\ \hline \end{array}, \begin{array}{|c|c|} \hline \bar{p} & \bar{q} \\ \hline \end{array} \right\}, \quad \mathbf{L}_{10} = \left\{ \begin{array}{|c|c|} \hline & \\ \hline \end{array}, \begin{array}{|c|c|} \hline & \\ \hline \end{array}, \begin{array}{|c|} \hline i \\ \hline j \\ \hline \end{array}, \begin{array}{|c|} \hline \bar{p} \\ \hline \bar{q} \\ \hline \end{array} \right\}, \quad (3.5.40)$$

$$\mathbf{L}_{11} = \left\{ \begin{array}{|c|c|} \hline \square & \square \\ \hline \square & \square \\ \hline \end{array}, \begin{array}{|c|} \hline \square \\ \hline \end{array}, \begin{array}{|c|c|} \hline \square & j \\ \hline \end{array}, \begin{array}{|c|} \hline p \\ \hline \end{array} \right\}, \quad \mathbf{L}_{12} = \left\{ \begin{array}{|c|c|} \hline \square & \square \\ \hline \square & \square \\ \hline \end{array}, \begin{array}{|c|} \hline \square \\ \hline \end{array}, \begin{array}{|c|} \hline i \\ \hline \end{array}, \begin{array}{|c|c|} \hline p & q \\ \hline \end{array} \right\}, \quad (3.5.41)$$

$$\mathbf{L}_{13} = \left\{ \begin{array}{|c|c|} \hline \square & \square \\ \hline \square & \square \\ \hline \end{array}, \begin{array}{|c|c|} \hline \square & \square \\ \hline \end{array}, \begin{array}{|c|c|} \hline i & j \\ \hline \end{array}, \begin{array}{|c|c|} \hline p & q \\ \hline \end{array} \right\}, \quad \mathbf{L}_{14} = \left\{ \begin{array}{|c|c|} \hline \square & \square \\ \hline \square & \square \\ \hline \end{array}, \begin{array}{|c|} \hline \square \\ \hline \end{array}, \begin{array}{|c|} \hline i \\ \hline \end{array}, \begin{array}{|c|} \hline p \\ \hline \end{array} \right\} \quad (3.5.42)$$

As usual, we left the states $\begin{array}{|c|c|} \hline i & j \\ \hline \end{array}$ and $\begin{array}{|c|} \hline i \\ \hline \end{array}$ (with $i, j = 1, 2, \dots, F$) of the symmetric and antisymmetric representation of $SU(F)$ unspecified.

The quiver Schurs explicitly read

$$\begin{aligned} \mathcal{O}(\mathbf{L}_1) &= \frac{f_{i,j} f_{\bar{p},\bar{q}}}{\sqrt{3!}} \left(2(\bar{Q}Q)_{(i)}^{(\bar{p})} (\bar{Q}\phi\phi Q)_{(j)}^{(\bar{q})} + (\bar{Q}\phi Q)_{(i)}^{(\bar{p})} (\bar{Q}\phi Q)_{(j)}^{(\bar{q})} + \frac{1}{2}(\bar{Q}Q)_{(i)}^{(\bar{p})} (\bar{Q}Q)_{(j)}^{(\bar{q})} (\phi)^2 + \right. \\ &\quad \left. + \frac{1}{2}(\bar{Q}Q)_{(i)}^{(\bar{p})} (\bar{Q}Q)_{(j)}^{(\bar{q})} (\phi\phi) + 2(\bar{Q}Q)_{(i)}^{(\bar{p})} (\bar{Q}\phi Q)_{(j)}^{(\bar{q})} (\phi) \right), \\ \mathcal{O}(\mathbf{L}_2) &= \frac{1}{\sqrt{3!}} \left(2(\bar{Q}Q)_{[i]}^{[\bar{p}]} (\bar{Q}\phi\phi Q)_{[j]}^{[\bar{q}]} + (\bar{Q}\phi Q)_{[i]}^{[\bar{p}]} (\bar{Q}\phi Q)_{[j]}^{[\bar{q}]} + \frac{1}{2}(\bar{Q}Q)_{[i]}^{[\bar{p}]} (\bar{Q}Q)_{[j]}^{[\bar{q}]} (\phi)^2 + \right. \\ &\quad \left. - \frac{1}{2}(\bar{Q}Q)_{[i]}^{[\bar{p}]} (\bar{Q}Q)_{[j]}^{[\bar{q}]} (\phi\phi) - 2(\bar{Q}Q)_{[i]}^{[\bar{p}]} (\bar{Q}\phi Q)_{[j]}^{[\bar{q}]} (\phi) \right), \\ \mathcal{O}(\mathbf{L}_3) &= \frac{f_{i,j} f_{\bar{p},\bar{q}}}{2\sqrt{2}} \left(-2(\bar{Q}\phi Q)_{(i)}^{(\bar{p})} (\bar{Q}\phi Q)_{(j)}^{(\bar{q})} + (\bar{Q}Q)_{(i)}^{(\bar{p})} (\bar{Q}Q)_{(j)}^{(\bar{q})} (\phi)^2 + (\bar{Q}Q)_{(i)}^{(\bar{p})} (\bar{Q}Q)_{(j)}^{(\bar{q})} (\phi\phi) \right), \\ \mathcal{O}(\mathbf{L}_4) &= \frac{f_{i,j} f_{\bar{p},\bar{q}}}{2\sqrt{2}} \left(-2(\bar{Q}Q)_{(i)}^{(\bar{p})} (\bar{Q}\phi\phi Q)_{(j)}^{(\bar{q})} + (\bar{Q}Q)_{(i)}^{(\bar{p})} (\bar{Q}Q)_{(j)}^{(\bar{q})} (\phi)^2 + \right. \\ &\quad \left. - (\bar{Q}Q)_{(i)}^{(\bar{p})} (\bar{Q}Q)_{(j)}^{(\bar{q})} (\phi\phi) + 2(\bar{Q}Q)_{(i)}^{(\bar{p})} (\bar{Q}\phi Q)_{(j)}^{(\bar{q})} (\phi) \right), \\ \mathcal{O}(\mathbf{L}_5) &= \frac{1}{2\sqrt{2}} \left(2(\bar{Q}Q)_{[i]}^{[\bar{p}]} (\bar{Q}\phi\phi Q)_{[j]}^{[\bar{q}]} + (\bar{Q}Q)_{[i]}^{[\bar{p}]} (\bar{Q}Q)_{[j]}^{[\bar{q}]} (\phi)^2 + \right. \\ &\quad \left. + (\bar{Q}Q)_{[i]}^{[\bar{p}]} (\bar{Q}Q)_{[j]}^{[\bar{q}]} (\phi\phi) + 2(\bar{Q}Q)_{[i]}^{[\bar{p}]} (\bar{Q}\phi Q)_{[j]}^{[\bar{q}]} (\phi) \right), \quad (3.5.43) \\ \mathcal{O}(\mathbf{L}_6) &= -f_{i,j} \left((\bar{Q}Q)_{(i)}^{(\bar{p})} (\bar{Q}\phi\phi Q)_{(j)}^{(\bar{q})} + (\bar{Q}Q)_{(i)}^{(\bar{p})} (\bar{Q}\phi Q)_{(j)}^{(\bar{q})} (\phi) \right), \\ \mathcal{O}(\mathbf{L}_7) &= -f_{\bar{p},\bar{q}} \left((\bar{Q}Q)_{[i]}^{[\bar{p}]} (\bar{Q}\phi\phi Q)_{[j]}^{[\bar{q}]} + (\bar{Q}Q)_{[i]}^{[\bar{p}]} (\bar{Q}\phi Q)_{[j]}^{[\bar{q}]} (\phi) \right), \\ \mathcal{O}(\mathbf{L}_8) &= \frac{1}{2\sqrt{2}} \left(-2(\bar{Q}\phi Q)_{[i]}^{[\bar{p}]} (\bar{Q}\phi Q)_{[j]}^{[\bar{q}]} + (\bar{Q}Q)_{[i]}^{[\bar{p}]} (\bar{Q}Q)_{[j]}^{[\bar{q}]} (\phi)^2 - (\bar{Q}Q)_{[i]}^{[\bar{p}]} (\bar{Q}Q)_{[j]}^{[\bar{q}]} (\phi\phi) \right), \\ \mathcal{O}(\mathbf{L}_9) &= \frac{f_{i,j} f_{\bar{p},\bar{q}}}{2\sqrt{2}} \left(2(\bar{Q}Q)_{(i)}^{(\bar{p})} (\bar{Q}\phi\phi Q)_{(j)}^{(\bar{q})} + (\bar{Q}Q)_{(i)}^{(\bar{p})} (\bar{Q}Q)_{(j)}^{(\bar{q})} (\phi)^2 + \right. \\ &\quad \left. - (\bar{Q}Q)_{(i)}^{(\bar{p})} (\bar{Q}Q)_{(j)}^{(\bar{q})} (\phi\phi) - 2(\bar{Q}Q)_{(i)}^{(\bar{p})} (\bar{Q}\phi Q)_{(j)}^{(\bar{q})} (\phi) \right), \end{aligned}$$

$$\begin{aligned}
 \mathcal{O}(\mathbf{L}_{10}) &= \frac{1}{2\sqrt{2}} \left(-2(\bar{Q}Q)_{[i}^{[\bar{p}} (\bar{Q}\phi\phi Q)_{j]}^{\bar{q}]} + (\bar{Q}Q)_{[i}^{[\bar{p}} (\bar{Q}Q)_{j]}^{\bar{q}]} (\phi)^2 + \right. \\
 &\quad \left. + (\bar{Q}Q)_{[i}^{[\bar{p}} (\bar{Q}Q)_{j]}^{\bar{q}]} (\phi\phi) - 2(\bar{Q}Q)_{[i}^{[\bar{p}} (\bar{Q}\phi Q)_{j]}^{\bar{q}]} (\phi) \right), \\
 \mathcal{O}(\mathbf{L}_{11}) &= -f_{i,j} \left((\bar{Q}Q)_{[i}^{[\bar{p}} (\bar{Q}\phi\phi Q)_{j]}^{\bar{q}]} - (\bar{Q}Q)_{[i}^{[\bar{p}} (\bar{Q}\phi Q)_{j]}^{\bar{q}]} (\phi) \right), \\
 \mathcal{O}(\mathbf{L}_{12}) &= -f_{\bar{p},\bar{q}} \left((\bar{Q}Q)_{[i}^{(\bar{p}} (\bar{Q}\phi\phi Q)_{j]}^{\bar{q})} - (\bar{Q}Q)_{[i}^{(\bar{p}} (\bar{Q}\phi Q)_{j]}^{\bar{q})} (\phi) \right), \\
 \mathcal{O}(\mathbf{L}_{13}) &= \frac{f_{i,j} f_{\bar{p},\bar{q}}}{\sqrt{3}} \left(-(\bar{Q}Q)_{[i}^{(\bar{p}} (\bar{Q}\phi\phi Q)_{j]}^{\bar{q})} + (\bar{Q}\phi Q)_{[i}^{(\bar{p}} (\bar{Q}\phi Q)_{j]}^{\bar{q})} + \frac{1}{2}(\bar{Q}Q)_{[i}^{(\bar{p}} (\bar{Q}Q)_{j]}^{\bar{q})} (\phi)^2 + \right. \\
 &\quad \left. + \frac{1}{2}(\bar{Q}Q)_{[i}^{(\bar{p}} (\bar{Q}Q)_{j]}^{\bar{q})} (\phi\phi) - (\bar{Q}Q)_{[i}^{(\bar{p}} (\bar{Q}\phi Q)_{j]}^{\bar{q})} (\phi) \right), \\
 \mathcal{O}(\mathbf{L}_{14}) &= \frac{1}{\sqrt{3}} \left(-(\bar{Q}Q)_{[i}^{[\bar{p}} (\bar{Q}\phi\phi Q)_{j]}^{\bar{q}]} + (\bar{Q}\phi Q)_{[i}^{[\bar{p}} (\bar{Q}\phi Q)_{j]}^{\bar{q}]} + \frac{1}{2}(\bar{Q}Q)_{[i}^{[\bar{p}} (\bar{Q}Q)_{j]}^{\bar{q}]} (\phi)^2 + \right. \\
 &\quad \left. - \frac{1}{2}(\bar{Q}Q)_{[i}^{[\bar{p}} (\bar{Q}Q)_{j]}^{\bar{q}]} (\phi\phi) + (\bar{Q}Q)_{[i}^{[\bar{p}} (\bar{Q}\phi Q)_{j]}^{\bar{q}]} (\phi) \right)
 \end{aligned}$$

The convention for round and square brackets around flavour indices is the same as the one used in the previous example. The computation that leads to this result is summarised in Appendix A.4. Using Mathematica, we checked that all these operators are orthogonal in the free field metric, that their norm satisfy (3.3.1), and that they obey the finite N constraints (3.3.3).

Chapter 4

Permutation Centraliser Algebras

This chapter lays the grounds for a systematic understanding of the algebraic structures involved in the resolution of the gauge invariant operator spectrum [54]. To be more precise, we will define the notion of *permutation centralizer algebras*. A particular class of these, denoted as $\mathcal{A}(m, n)$, will be our main focus. Many of the important formulae we will use have already appeared in the physics literature. Nevertheless the $\mathcal{A}(m, n)$, as associative algebras with non-degenerate pairing, have not been made fully explicit. This chapter, based on [2], proposes that these algebras are interesting to study intrinsically, disentangled from the contingencies of being embedded in a bigger symmetric group algebra, their simplicity hidden among the application to matrix correlators for matrices of size N . Here we define the algebras $\mathcal{A}(m, n)$, study their structure, and subsequently describe how they are relevant to matrix theory invariants. We expect that a deeper study of this algebraic structure has the potential to give a lot of information about correlators in free Yang-Mills theory, in the loop corrected theory, at all orders in the $1/N$ expansion. This work is a step in this direction. Much as it is valuable to abstract Riemannian geometry from the study of submanifolds of Euclidean spaces, abstracting a family of algebras intrinsic to permutations hidden in the mathematics of matrix theory should be fruitful.

In section 4.1 we introduce the definition of permutation centralizer algebras. We consider four key examples of these algebras, which are useful in the context of gauge-invariant operators. In section 4.2, we focus on the algebras $\mathcal{A}(m, n)$ formed by equivalence classes of permutations in S_{m+n} , with equivalence generated by conjugation with permutations in $S_m \times S_n$. The dimension of this algebra is

$$|\mathcal{A}(m, n)| = \sum_{\substack{R_1 \vdash m, R_2 \vdash n \\ R \vdash m+n}} g(R_1, R_2; R)^2 \quad (4.0.1)$$

where $g(R_1, R_2; R)$ is the LR coefficient for the triplet of Young diagram (R_1, R_2, R) made with $(m, n, m+n)$ boxes respectively. We will show that this is an associative algebra with a non-degenerate pairing. As a result, we know from the Wedderburn-Artin theorem that it is

isomorphic to a direct sum of matrix algebras $\mathcal{M}at$ [84, 85]:

$$\mathcal{A}(m, n) = \bigoplus_a \mathcal{M}at_a \quad (4.0.2)$$

In eq. (4.2.5) we give a more precise version of this formula, where the index a is identified with triplets (R_1, R_2, R) with non-vanishing LR coefficient $g(R_1, R_2; R)$. The construction of restricted Schur operators in gauge theory is used to give the Wedderburn-Artin decomposition of $\mathcal{A}(m, n)$. Two sub-algebras will be of interest. The centre of the algebra $\mathcal{Z}(m, n)$ is the subspace of the algebra which commutes with any element of $\mathcal{A}(m, n)$. The dimension of this centre is equal to the number of triples (R_1, R_2, R) of Young diagrams, with numbers of boxes equal to $(m, n, m + n)$, for which the LR coefficient is non-zero. It is useful to develop some formulae for the non-degenerate pairing on the centre, using characters of S_{m+n}, S_m, S_n . The Wedderburn-Artin decomposition also highlights the importance of a maximally commuting sub-algebra $\mathcal{M}(m, n)$. The dimension of this sub-algebra is the sum of Littlewood-Richardson coefficients $g(R_1, R_2; R)$. Appendix C.1 gives a multi-variable generating function for this sum of LR coefficients. We explain the relevance of this sub-algebra to the enhanced symmetry charges studied in [54]. In particular we give a precise algebraic characterization (4.3.45) for the *minimal number of charges needed to identify all 2-matrix gauge-invariant operators*. The evaluation of this number is an open problem for the future.

In section 4.3, we explain some further physical implications of the permutation centralizer algebras. The simplest of these algebras is the algebra of class sums of permutations. Given the one-to-one correspondence between matrix operators and conjugacy classes of permutations given in (1.2.9), this means that there is a corresponding product on half-BPS operators. This is not the usual product obtained by multiplying the gauge invariant operator built from X under which the dimension of the operator adds. The product on the class sums rather gives a product for the BPS operators of fixed dimension, a product which is associative and admits a non-degenerate pairing. We will refer to this as a *star product for half-BPS operators*. We explain the relevance of this star product for the computation of correlators. Similarly the product on the algebra $\mathcal{A}(m, n)$ gives a *star product for gauge invariant polynomials in two matrices*, with degree m in the X 's and degree n in the Y 's. In the physics application, there is a closed associative star product on the space of quarter-BPS operators at zero Yang-Mills coupling. Conversely the usual product of gauge invariants gives a product on $\mathcal{A}(\infty, \infty)$

$$\mathcal{A}(\infty, \infty) = \bigoplus_{m, n=0}^{\infty} \mathcal{A}(m, n) \quad (4.0.3)$$

which is the direct sum over all m, n . Thus $\mathcal{A}(\infty, \infty)$ has two products one of which closes at fixed m, n . This generalizes a structure seen in the study of symmetric polynomials.

In section 4.4, we show that the study of the structure of the algebra $\mathcal{A}(m, n)$ we developed in section 4.2 is useful for the computation of correlators of 2-matrix gauge invariants. In particular, we identify an *efficiently computable sector of central gauge invariant operators*

whose correlators can be computed using the knowledge of characters of S_{m+n}, S_m, S_n . It does not require the knowledge of more detailed data such as matrix elements $D_{ij}^R(\sigma)$ or branching coefficients for $S_{m+n} \rightarrow S_m \times S_n$. To illustrate the simplicity of this central sector, we compute the two-point function

$$\left\langle \text{Tr}(X^m Y^n) \text{Tr}((X^\dagger)^m (Y^\dagger)^n) \right\rangle \quad (4.0.4)$$

at finite N . The computation requires a calculation of Littlewood-Richardson coefficients $g(R_1, R_2; R)$ where R_1, R_2 are hook-shaped Young diagrams. This computation is given in Appendix C.2. Further technical aspects of the computation are given in Appendix C.3. The computation agrees with the one in [86] which was done with explicit Young-Yamanouchi symbols which can be used to construct states in irreps R and describe their reduction to R_1, R_2 .

4.1 Definitions and Key examples

When studying the representation theory of a group G , it is useful to introduce the algebra $\mathbb{C}[G]$ which consists of formal linear combinations of group elements, equipped with the multiplication inherited from the group. In the group algebra $\mathbb{C}[G]$, for each conjugacy class, we can form a sum over all the elements in the conjugacy class of G . Such class sums commute with any element of G and form the central sub-algebra of $\mathbb{C}[G]$, i.e. the sub-algebra which commutes with all $\mathbb{C}[G]$. We will refer to $\mathcal{Z}[\mathbb{C}[G]]$ as the centre of $\mathbb{C}[G]$. Conjugacy classes are in 1-1 correspondence with irreducible representations and there is a basis of the centre consisting of projectors of the form

$$P_R = \frac{d_R}{|G|} \sum_{g \in G} \chi_R(g) g^{-1} \quad (4.1.1)$$

Of primary interest to us is the group algebra of $\mathbb{C}[S_n]$ and its centre $\mathcal{Z}[\mathbb{C}[S_n]]$. The elements in $\mathcal{Z}[\mathbb{C}[S_n]]$ are formal sums of all the permutations belonging to a given conjugacy class t of S_n . Therefore we have that

$$\sum_{\sigma \in t} \sigma \in \mathcal{Z}[\mathbb{C}[G]] \quad (4.1.2)$$

Conversely, given any $\sigma \in S_n$, we can generate an element of this subalgebra by summing over all $\gamma \in S_n$:

$$\sum_{\gamma \in S_n} \gamma \sigma \gamma^{-1} \in \mathcal{Z}[\mathbb{C}[G]] \quad (4.1.3)$$

Some properties of group algebras and their centre can be found in [83, 84]. In the context of AdS/CFT, group algebras $\mathbb{C}[S_n]$ and associated representation theory play a role in the half-BPS sector of $\mathcal{N} = 4$ SYM in 4D [17, 18] and also in the symmetric orbifolds in AdS3/CFT2 [19, 87]. Motivated by developments in AdS/CFT we will introduce a generalization of this construction.

Definition: Consider an associative algebra \mathcal{A} containing a sub-algebra $\mathcal{B} = \mathbb{C}[H]$, the group

algebra of a finite group H . Now define the sub-space of \mathcal{A} of elements which are invariant under conjugation by H . This subspace will contain group averages of the form

$$\sum_{\gamma \in H} \gamma \sigma \gamma^{-1}, \quad \sigma \in \mathcal{A} \quad (4.1.4)$$

which commute with elements of \mathcal{B} . It is easy to verify that these sub-spaces are sub-algebras. We have

$$\left(\sum_{\gamma_1 \in H} \gamma_1 \sigma \gamma_1^{-1} \right) \left(\sum_{\gamma_2 \in H} \gamma_2 \sigma \gamma_2^{-1} \right) = \sum_{\gamma_1 \in H} \gamma_1 \left(\sum_{\gamma_3 \in H} \sigma_1 \gamma_3 \sigma_2 \gamma_3^{-1} \right) \gamma_1^{-1} \quad (4.1.5)$$

where we set $\gamma_3 = \gamma_1^{-1} \gamma_2$. This shows that the product of two group averages is still a group average. This sub-algebra of \mathcal{A} commuting with \mathcal{B} , in cases where H is a permutation group, will be called a *permutation centralizer algebra*.

Three cases of primary interest will be

- **Example 1** The algebra $\mathcal{A} = \mathbb{C}[S_n]$. The algebra $\mathcal{B} = \mathbb{C}[S_n]$. The centralizer of \mathbb{B} is $\mathcal{Z}[\mathbb{C}[S_n]]$.
- **Example 2** $\mathcal{A} = \mathbb{C}[S_{m+n}]$; $\mathcal{B} = \mathbb{C}[S_m \times S_n]$. We will call this algebra $\mathcal{A}(m, n)$.
- **Example 3** $\mathcal{A} = B_N(m, n)$ - the walled Brauer algebra; $\mathcal{B} = \mathbb{C}[S_m \times S_n]$. This algebra is called $\mathcal{B}_N(m, n)$.
- **Example 4** $\mathcal{A} = \mathbb{C}[S_n \times S_n]$; $\mathcal{B} = \mathbb{C}[S_n]$ where the latter is the S_n diagonally embedded in the product group. This should be called $\mathcal{K}(n)$.

The case where \mathcal{A} is itself a group algebra has been studied in mathematics, for example, in [88].

Our primary interest in this chapter will be in $\mathcal{A}(m, n)$ of example 2. $\mathcal{Z}[\mathbb{C}[S_n]]$ of Example 1 will be a useful guide and a source of analogies in our investigations. Fourier transformation on $\mathcal{A}(m, n)$ will be related to restricted Schur operators studied in AdS/CFT. These are parametrised by representation theory data (R, R_1, R_2, i, j) consisting of Young diagrams R_1, R_2, R with $m, n, m+n$ boxes as well as multiplicity indices i, j . The latter take values $1 \leq i, j \leq g(R_1, R_2; R)$ where $g(R_1, R_2; R)$ is the LR multiplicity for the triple of Young diagrams computed with the LR combinatoric rule (see for example [68]). Unlike $\mathcal{Z}[\mathbb{C}[S_n]]$, the algebra $\mathcal{A}(m, n)$ is not commutative. The central sub-algebra $\mathcal{Z}(m, n)$, consisting of the sub-space $\mathcal{Z}(m, n) \subset \mathcal{A}(m, n)$ which commutes with all of $\mathcal{A}(m, n)$ will play a predominant role. Likewise the algebras $\mathcal{B}_N(m, n)$ and $\mathcal{K}(n)$ in Examples 3 and 4 are non-commutative.

4.2 Structure of the $\mathcal{A}(m, n)$ algebra

The algebra $\mathcal{A}(m, n)$ is constructed by taking all the elements in $\mathbb{C}[S_{m+n}]$ which are invariant under $\mathbb{C}[S_m \times S_n]$. Any element of $\sigma \in \mathbb{C}[S_{m+n}]$ can be mapped to a $\bar{\sigma} \in \mathcal{A}(m, n)$ by the group

averaging

$$\bar{\sigma} = \sum_{\gamma \in S_m \times S_n} \gamma^{-1} \sigma \gamma \quad (4.2.1)$$

The $\bar{\sigma}$ are formal sums of permutations τ lying in the same orbit of σ under the $S_m \times S_n$ action. Each τ has a stabiliser group, given by those $\gamma \in S_m \times S_n$ for which

$$\gamma^{-1} \tau \gamma = \sigma \quad (4.2.2)$$

The stabilisers of two permutations τ_1, τ_2 in the same orbit are generally different (they are conjugate to each other), but they have the same dimension. By the Orbit-Stabiliser theorem, $\bar{\sigma}$ is then a sum of permutations weighted by the same coefficient:

$$\bar{\sigma} = |\text{Aut}_{S_m \times S_n}(\sigma)| \sum_{\tau \in \text{Orbit}(\sigma, S_m \times S_n)} \tau \quad (4.2.3)$$

$\mathcal{A}(m, n)$ is a finite-dimensional associative algebra (the associativity follows from the associativity of $\mathbb{C}[S_{m+n}]$), which we can equip with the non-degenerate symmetric bilinear form

$$\langle \bar{\sigma}_1, \bar{\sigma}_2 \rangle = \delta(\bar{\sigma}_1 \bar{\sigma}_2), \quad \bar{\sigma}_{1,2} \in \mathcal{A}(m, n) \quad (4.2.4)$$

Here the delta function on the group algebra $\mathbb{C}[S_{m+n}]$ is a linear function which obeys $\delta(\sigma) = 1$ for $\sigma = 1$ and $\delta(\sigma) = 0$ otherwise.

The non-degeneracy of the bilinear form (4.2.4) implies that $\mathcal{A}(m, n)$ is semi-simple. According to the Wedderburn-Artin theorem, it can then be decomposed into a direct sum of matrix algebras:

$$\mathcal{A}(m, n) = \bigoplus_{\substack{R \vdash m+n \\ R_1 \vdash m, R_2 \vdash n}} \text{Span}\{Q_{R_1, R_2, i, j}^R; i, j\} \quad (4.2.5)$$

In this equation R, R_1 and R_2 are representations of S_{m+n}, S_m and S_n respectively. The integers i, j run over the multiplicity $g(R_1, R_2; R)$ of the branching $R \rightarrow R_1 \otimes R_2$: $0 \leq i, j \leq g(R_1, R_2; R)$. An explicit expression for $Q_{R_1, R_2, i, j}^R$ is given in terms of the restricted Schur characters [26, 30, 54], defined as

$$\chi_{R_1, R_2, i, j}^R(\sigma) = D_{m, m'}^R(\sigma) B_{m' \rightarrow l_1, l_2}^{R \rightarrow R_1, R_2; i} B_{m \rightarrow l_1, l_2}^{R \rightarrow R_1, R_2; j} \quad (4.2.6)$$

These objects have already been introduced in equation (1.2.39). Here $D_{m, m'}^R(\sigma)$ are the matrix elements of σ in the irreducible representation R . $B_{m \rightarrow l_1, l_2}^{R \rightarrow R_1, R_2; j}$ is the branching coefficient for the representation branching $R \rightarrow R_1 \otimes R_2$, in the j -th copy of $R_1 \otimes R_2 \subset R$. $l_{1,2}$ are states in $R_{1,2}$. The restricted Schur characters $\chi_{R_1, R_2, i, j}^R(\sigma)$ are invariant under conjugation by

$\mathbb{C}[S_m \times S_n]$ elements. With these definitions we can write

$$Q_{R_1, R_2, i, j}^R = \sum_{\sigma} \chi_{R_1, R_2, i, j}^R(\sigma) \sigma \quad (4.2.7)$$

which is manifestly invariant under the action of $\mathbb{C}[S_m \times S_n]$. It follows that

$$Q_{R_1, R_2, i, j}^R Q_{S_1, S_2, k, l}^S = \delta^{R, S} \delta_{R_1, S_1} \delta_{R_2, S_2} (\delta_{jk} Q_{R_1, R_2, i, l}^R) \quad (4.2.8)$$

This is in accordance with the decomposition (4.2.5). Consequently it is useful to write $Q_{R_1, R_2, i, j}^R$ as

$$Q_{R_1, R_2, i, j}^R = \sum_{m_1, m_2} |R \rightarrow R_1, R_2, m_1, m_2, i\rangle \langle R \rightarrow R_1, R_2, m_1, m_2, j| \quad (4.2.9)$$

Moreover, the basis $\{Q_{R_1, R_2, i, j}^R\}$ is complete as we now explain. The number of distinct $Q_{R_1, R_2, i, j}^R$'s is equal to the number of restricted Schur characters, which is in turn equal to $\sum_{R_1, R_2, R} g(R_1, R_2; R)^2$. On the other hand the dimension of $\mathcal{A}(m, n)$ is by definition equal to the number of elements of $\mathbb{C}[S_{m+n}]$ invariant under the $\mathbb{C}[S_m \times S_n]$ action. Using the Burnside lemma, it is possible to show that this dimension $|\mathcal{A}(m, n)|$ is given as

$$|\mathcal{A}(m, n)| = \sum_{\substack{R_1 \vdash m, R_2 \vdash n \\ R \vdash m+n}} g(R_1, R_2, R)^2 \quad (4.2.10)$$

In each of the blocks in (4.2.5) there is a projector of the form $P_{R_1, R_2}^R = \sum_i Q_{R_1, R_2, i, i}^R$. Let now P_R , P_{R_1} and P_{R_2} be the projectors onto the irreps R, R_1 and R_2 of S_{m+n} , S_m and S_n respectively. Since

$$\begin{aligned} & \langle R \rightarrow R_1, R_2, m_1, m_2, i | P_R P_{R_1} P_{R_2} | R \rightarrow R_1, R_2, m'_1, m'_2, j \rangle \\ &= \langle R \rightarrow R_1, R_2, m_1, m_2, i | P_{R_1, R_2}^R | R \rightarrow R_1, R_2, m'_1, m'_2, j \rangle = \delta_{m_1, m'_1} \delta_{m_2, m'_2} \delta_{i, j} \end{aligned} \quad (4.2.11)$$

for all triplets R, R_1, R_2 , we can write

$$P_{R_1, R_2}^R = P_R P_{R_1} P_{R_2} \quad (4.2.12)$$

so that the projectors P_{R_1, R_2}^R are just products of ordinary S_{m+n} , S_m and S_n projectors. The set $\{P_{R_1, R_2}^R\}$ forms a basis for the centre of $\mathcal{A}(m, n)$, which we call $\mathcal{Z}(m, n)$. Its dimension is then given by the number of non vanishing LR coefficients $g(R_1, R_2; R)$, or

$$|\mathcal{Z}(m, n)| = \sum_{\substack{R_1 \vdash m, R_2 \vdash n \\ R \vdash m+n}} (1 - \delta(g(R_1, R_2; R))) \quad (4.2.13)$$

Here $\delta(g(R_1, R_2; R)) = 1$ if $g(R_1, R_2; R) = 0$ and $\delta(g(R_1, R_2; R)) = 0$ otherwise. The generating

function for the dimension of the centre is [25]

$$\mathcal{Z}(x, y) = \prod_i \frac{1}{(1 - x^i - y^i)} \quad (4.2.14)$$

We will now argue that the collection of the generators of the centres of $\mathbb{C}[S_{m+n}]$, $\mathbb{C}[S_m]$ and $\mathbb{C}[S_n]$, that we denote as $\{T_p^{(m+n)}\}$, $\{T_{q_1}^{(m)}\}$ and $\{T_{q_2}^{(n)}\}$ respectively, is a set of generators for $\mathcal{Z}(m, n)$. Here p , q_1 and q_2 are integer partitions of $m+n$, m and n respectively. For example, for the partition $p = (p_1, p_2, \dots)$ of $m+n$, the operator $T_p^{(m+n)}$ consists of a sum over permutations belonging to the conjugacy class $p = (p_1, p_2, \dots)$:

$$T_p^{(m+n)} = \sum_{i_1, \dots, i_{p_1+p_2+\dots} \in [m+n]} (i_1 i_2 \cdots i_{p_1}) (i_{p_1+1} i_{p_1+2} \cdots i_{p_1+p_2}) \cdots \quad (4.2.15)$$

$T_p^{(m+n)}$ are sums of conjugates by elements of S_{m+n} , whereas $T_{q_1}^{(m)}$ and $T_{q_2}^{(n)}$ are sums over $S_m \subset S_{m+n}$ and $S_n \subset S_{m+n}$ respectively. To show that $\{T_p^{(m+n)}, T_{q_1}^{(m)}, T_{q_2}^{(n)}\}$ generate the whole centre $\mathcal{Z}(m, n)$ we can use the following argument. Using the Wedderburn-Artin decomposition (4.2.5), we see that the centre of $\mathcal{A}(m, n)$ is the direct sum of the centres of the matrix algebras $\text{Span}\{Q_{R_1, R_2, i, j}^R; i, j\}$. For each of these matrix blocks, that is for any fixed representations R, R_1, R_2 for which $g(R_1, R_2; R) \neq 0$, the centre is one-dimensional, and is spanned by

$$P_{R_1, R_2}^R = \sum_{i=1} Q_{R_1, R_2, i, i}^R \quad (4.2.16)$$

Using the equation (4.2.8), it is immediate to check that

$$[P_{R_1, R_2}^R, Q_{R_1, R_2, i, j}^R] = 0, \quad \forall i, j \quad (4.2.17)$$

We know that $P_{R_1, R_2}^R = P_R P_{R_1} P_{R_2}$, with P_R, P_{R_1} and P_{R_2} projectors on the representations R, R_1 and R_2 . Therefore every central element of $\mathcal{A}(m, n)$ can be generated with the collection of projectors $\{P_R, P_{R_1}, P_{R_2}\}$. For an R irrep of S_n , the projector is

$$P_R = \frac{1}{n!} \sum_{\sigma \in S_n} \chi_R(\sigma) \sigma = \frac{1}{n!} \sum_{p \in \text{Partitions}(n)} \chi_R(\sigma_p) T_p^{(n)} \quad (4.2.18)$$

where σ_p is a representative permutation belonging to the conjugacy class $p \vdash n$. This means that every projector P_R can be written as a linear combination of the central elements $\{T_p^{(n)}\}$. We can then write the set $\{P_R, P_{R_1}, P_{R_2}\}$ in terms of the central elements $\{T_p^{(m+n)}, T_{q_1}^{(m)}, T_{q_2}^{(n)}\}$. Since we know that the former generates the whole $\mathcal{Z}(m, n)$, we can now conclude that the latter is a complete set of generators for the centre $\mathcal{Z}(m, n)$ as well. The basis thus obtained will be useful in the following sections. However, it is important to point out that such a basis is overcomplete. An easy way to see it is to note that, given (4.2.12), $P_R P_{R_1} P_{R_2} = 0$ if $g(R_1, R_2, R) = 0$. Therefore, taking a triplet (R_1, R_2, R) for which $g(R_1, R_2, R) = 0$ we have,

using (4.2.18):

$$\frac{1}{(m+n)!m!n!} \sum_{\substack{p \vdash (m+n) \\ q_1 \vdash m, q_2 \vdash n}} \chi_R(\sigma_p) \chi_{R_1}(\sigma_{q_1}) \chi_{R_2}(\sigma_{q_2}) T_p^{(m+n)} T_{q_1}^{(m)} T_{q_2}^{(n)} = 0 \quad (4.2.19)$$

This shows that $\{T_p^{(m+n)}, T_{q_1}^{(m)}, T_{q_2}^{(n)}\}$ is indeed an overcomplete basis.

We can also argue that $\{T_p^{(m+n)}, T_{q_1}^{(m)}, T_{q_2}^{(n)}\}$ generate $\mathcal{Z}(m, n)$ just by using the Schur-Weyl duality as in [54]. The $T^{(m)}$ elements are Schur-Weyl dual to $U(N)$ Casimirs acting on the upper m indices of X -type matrices. This action is generated by

$$(E_x)_j^i = (D_x)_j^i = X_l^i \frac{\partial}{\partial X_l^j} \quad (4.2.20)$$

The $T^{(n)}$ elements are Schur-Weyl dual to $U(N)$ Casimirs acting on the upper n indices of Y -type matrices. We have

$$(E_y)_j^i = (D_y)_j^i = Y_l^i \frac{\partial}{\partial Y_l^j} \quad (4.2.21)$$

Finally, the $T^{(m+n)}$ elements are Schur-Weyl dual to $U(N)$ Casimirs acting on the upper n and m indices of both X - and Y -type matrices, and the generator is

$$E_j^i = (E_x)_j^i + (E_y)_j^i \quad (4.2.22)$$

We then have three distinct types of Casimirs:

$$\begin{aligned} C_k^{(m+n)} &= E_{i_2}^{i_1} E_{i_3}^{i_2} \cdots E_{i_1}^{i_k} \\ C_k^{(m)} &= (E_x)_{i_2}^{i_1} (E_x)_{i_3}^{i_2} \cdots (E_x)_{i_1}^{i_k} \\ C_k^{(n)} &= (E_y)_{i_2}^{i_1} (E_y)_{i_3}^{i_2} \cdots (E_y)_{i_1}^{i_k} \end{aligned} \quad (4.2.23)$$

But the $C_k^{(m+n)}$, the $C_k^{(m)}$ and the $C_k^{(n)}$ operators measure respectively the R , R_1 and R_2 labels of the restricted Schurs $\chi_{R_1, R_2, i, j}^R$. Therefore they can be used to isolate every subspace $R_1 \otimes R_2 \subseteq R$, and to build all the correspondent projectors P_{R_1, R_2}^R . Since we know that each of these projectors is in a 1-1 correspondence with an element of $\mathcal{Z}(m, n)$, the whole centre $\mathcal{Z}(m, n)$ is obtained.

On the other hand, non-central elements are needed to measure the multiplicity labels i, j . This observation will be developed in section 4.3.

4.2.1 Symmetric group characters and the pairing on the centre $\mathcal{Z}(m, n)$

A central element $Z_a \in \mathcal{Z}(m, n)$ can be expanded in terms of the projectors P_{R_1, R_2}^R as

$$Z_a = \sum_{R, R_1, R_2} Z_a^{R, R_1, R_2} P_{R_1, R_2}^R \quad (4.2.24)$$

We can then define

$$\begin{aligned} \chi_{R_1, R_2; i, j}^R(Z_a) &= \sum_{m_1, m_2} \langle R \rightarrow R_1, R_2, m_1, m_2, i | Z_a | R \rightarrow R_1, R_2, m_1, m_2, j \rangle \\ &= \delta_{ij} \sum_{S, S_1, S_2} \sum_{m_1, m_2} Z_a^{S, S_1, S_2} \langle R \rightarrow R_1, R_2, m_1, m_2, i | P_{S_1, S_2}^S | R \rightarrow R_1, R_2, m_1, m_2, j \rangle \\ &= \delta_{ij} Z_a^{R, R_1, R_2} d_{R_1} d_{R_2} \end{aligned} \quad (4.2.25)$$

and

$$\chi_{R_1, R_2}^R(Z_a) = \sum_i \chi_{R_1, R_2; i, i}^R(Z_a) = Z_a^{R, R_1, R_2} g(R_1, R_2, R) d_{R_1} d_{R_2} \quad (4.2.26)$$

From these equations it also follows that for any central element Z_a

$$\chi_{R_1, R_2; i, j}^R(Z_a) = \frac{\delta_{i, j}}{g(R_1, R_2; R)} \chi_{R_1, R_2}^R(Z_a) \quad (4.2.27)$$

Another useful expansion is in terms of $\{T_p^{(m+n)}\}$, $\{T_{q_1}^{(m)}\}$ and $\{T_{q_2}^{(n)}\}$. Since these elements generate the centre, we can write

$$Z_a = Z_a^{p, q_1, q_2} T_p^{(m+n)} T_{q_1}^{(m)} T_{q_2}^{(n)} \quad (4.2.28)$$

for some Z_a^{p, q_1, q_2} coefficients. However, since the basis generated by $\{T_p^{(m+n)}, T_{q_1}^{(m)}, T_{q_2}^{(n)}\}$ is overcomplete, such coefficients are not unique. Using the expansion (4.2.28), we can write

$$\chi_{R_1, R_2; i, j}^R(Z_a) = \delta_{ij} Z_a^{p, q_1, q_2} \frac{\chi_R(T_p^{(m+n)})}{d_R} \chi_{R_1}(T_{q_1}^{(m)}) \chi_{R_2}(T_{q_2}^{(n)}) \quad (4.2.29)$$

and

$$\chi_{R_1, R_2}^R(Z_a) = \sum_i \chi_{R_1, R_2; i, i}^R(Z_a) = Z_a^{p, q_1, q_2} g(R_1, R_2, R) \frac{\chi_R(T_p^{(m+n)})}{d_R} \chi_{R_1}(T_{q_1}^{(m)}) \chi_{R_2}(T_{q_2}^{(n)}) \quad (4.2.30)$$

From these equations we see that all the restricted characters of central elements are determined by characters of S_{m+n}, S_m, S_n . Just as the centre of S_n is generated by class sums, which are dual to irreducible characters of S_n , the centre $\mathcal{Z}(m, n)$ of $\mathcal{A}(m, n)$ is dual to the characters χ_{R_1, R_2}^R , which are nothing but products of symmetric group characters. Therefore, to compute restricted

characters of elements in $\mathcal{Z}(m, n)$ we only need the ordinary symmetric group character theory.

We will now use some of the known equations for the character of symmetric group and use them to compute restricted characters in $\mathcal{Z}(m, n)$. Our aim will be to compute the dual pairing (4.2.4) for central elements. Equation (B.12) in [26] reads

$$\frac{(m+n)!}{m!n!} \sum_{\gamma \in S_m \times S_n} \delta(\sigma\gamma\tau\gamma^{-1}) = \sum_{R, R_1, R_2, i, j} \frac{d_R}{d_{R_1}d_{R_2}} \chi_{R_1, R_2, i, j}^R(\sigma) \chi_{R_1, R_2, i, j}^R(\tau) \quad (4.2.31)$$

By setting $\tau = 1$ this equation simplifies to

$$(m+n)! \delta(\sigma) = \sum_R d_R \chi_{R_1, R_2, i, j}^R(\sigma) \quad (4.2.32)$$

where we used

$$\chi_{R_1, R_2, i, j}^R(1) = \delta_{ij} d_{R_1} d_{R_2} \quad (4.2.33)$$

We can immediately use this result to show that $\delta(Q_{R_1, R_2, i, j}^R) = \delta_{ij} d_{R_1} d_{R_2}$. This is because, using (4.2.7)

$$\delta(Q_{R_1, R_2, i, j}^R) = \sum_{\sigma} \chi_{R_1, R_2, i, j}^R(\sigma) \delta(\sigma) = \chi_{R_1, R_2, i, j}^R(1) = \delta_{ij} d_{R_1} d_{R_2} \quad (4.2.34)$$

It is also worthwhile to notice that, for $\mathcal{O} \in \mathcal{A}(m, n)$, $\text{Tr}(\mathcal{O}) = \delta(\mathcal{O})$. Therefore we could have obtained the same result by considering

$$\begin{aligned} \text{Tr}(Q_{R_1, R_2, i, j}^R) &= \sum_{S, S_1, S_2} \sum_{\substack{m_1, m_2 \\ m'_1, m'_2}} \sum_k \langle S \rightarrow S_1, S_2, m'_1, m'_2, k | R \rightarrow R_1, R_2, m_1, m_2, i \rangle \\ &\quad \times \langle R \rightarrow R_1, R_2, m_1, m_2, j | S \rightarrow S_1, S_2, m'_1, m'_2, k \rangle \\ &= \delta_{ij} d_{R_1} d_{R_2} \end{aligned} \quad (4.2.35)$$

where we used the definition (4.2.9).

Let us now go back to eq. (4.2.32). If we replace σ by a central element Z_a , using the expansion (4.2.28) and eq. (4.2.30), we find

$$(m+n)! \delta(Z_a) = \sum_{R, R_1, R_2} Z_a^{p, q_1, q_2} g(R_1, R_2, R) \chi_R(T_p^{(m+n)}) \chi_{R_1}(T_{q_1}^{(m)}) \chi_{R_2}(T_{q_2}^{(n)}) \quad (4.2.36)$$

By further replacing $\sigma \rightarrow Z_a, \tau \rightarrow Z_b$ in (4.2.31) we get, in a similar fashion

$$\begin{aligned}
 (m+n)! \delta(Z_a Z_b) &= \sum_{R, R_1, R_2, i, j} \frac{d_R}{d_{R_1} d_{R_2}} \chi_{R_1, R_2, i, j}^R(Z_a) \chi_{R_1, R_2, i, j}^R(Z_b) \\
 &= Z_a^{p, q_1, q_2} Z_b^{p', q'_1, q'_2} \sum_{R, R_1, R_2} \frac{g(R_1, R_2, R)}{d_R d_{R_1} d_{R_2}} \times \\
 &\quad \times \chi_R(T_p^{(m+n)}) \chi_{R_1}(T_{q_1}^{(m)}) \chi_{R_2}(T_{q_2}^{(n)}) \chi_R(T_{p'}^{(m+n)}) \chi_{R_1}(T_{q'_1}^{(m)}) \chi_{R_2}(T_{q'_2}^{(n)})
 \end{aligned} \tag{4.2.37}$$

Comparing the LHS above with eq. (4.2.4) we find that for central elements Z_a, Z_b

$$\begin{aligned}
 \langle Z_a, Z_b \rangle &= Z_a^{p, q_1, q_2} Z_b^{p', q'_1, q'_2} \frac{1}{(m+n)!} \sum_{R, R_1, R_2} \frac{g(R_1, R_2, R)}{d_R d_{R_1} d_{R_2}} \times \\
 &\quad \times \chi_R(T_p^{(m+n)}) \chi_{R_1}(T_{q_1}^{(m)}) \chi_{R_2}(T_{q_2}^{(n)}) \chi_R(T_{p'}^{(m+n)}) \chi_{R_1}(T_{q'_1}^{(m)}) \chi_{R_2}(T_{q'_2}^{(n)})
 \end{aligned} \tag{4.2.38}$$

Thus we have an explicit way of computing the dual pairing on the centre $\mathcal{Z}(m, n)$ in terms of ordinary S_n characters.

Similarly, there is a character expansion for $\delta(Z_a Z_b Z_c)$. We begin by writing

$$\begin{aligned}
 (m+n)! \delta(Z_a Z_b Z_c) &= \sum_{R, R_1, R_2, i, j} \frac{d_R}{d_{R_1} d_{R_2}} \chi_{R_1, R_2, i, j}^R(Z_a Z_b) \chi_{R_1, R_2, i, j}^R(Z_c) \\
 &= \sum_{R, R_1, R_2} \frac{d_R}{d_{R_1} d_{R_2} g(R_1, R_2; R)} \chi_{R_1, R_2}^R(Z_a Z_b) \chi_{R_1, R_2}^R(Z_c)
 \end{aligned} \tag{4.2.39}$$

Since Z_a is central, $Z_a = (c_a)_{R_1, R_2}^R 1$, where $(c_a)_{R_1, R_2}^R$ is a constant. This constant can be obtained by considering:

$$\chi_{R_1, R_2, i, j}^R(Z_a) = (c_a)_{R_1, R_2}^R \chi_{R_1, R_2}^R(1) = (c_a)_{R_1, R_2}^R d_{R_1} d_{R_2} g(R_1, R_2; R) \tag{4.2.40}$$

We therefore have that

$$\chi_{R_1, R_2}^R(Z_a Z_b) = \frac{\chi_{R_1, R_2}^R(Z_a) \chi_{R_1, R_2}^R(Z_b)}{d_{R_1} d_{R_2} g(R_1, R_2; R)} \tag{4.2.41}$$

Using (4.2.41) in (4.2.39), and then exploiting (4.2.30), we obtain

$$\begin{aligned}
 (m+n)! \delta(Z_a Z_b Z_c) &= \sum_{R, R_1, R_2} \frac{d_R}{d_{R_1}^2 d_{R_2}^2 g(R_1, R_2; R)^2} \chi_{R_1, R_2}^R(Z_a) \chi_{R_1, R_2}^R(Z_b) \chi_{R_1, R_2}^R(Z_c) \\
 &= Z_a^{p, q_1, q_2} Z_b^{p', q'_1, q'_2} Z_c^{p'', q''_1, q''_2} \sum_{R, R_1, R_2} \frac{g(R_1, R_2; R)}{d_R^2 d_{R_1}^2 d_{R_2}^2} \chi_R(T_p^{(m+n)}) \chi_{R_1}(T_{q_1}^{(m)}) \chi_{R_2}(T_{q_2}^{(n)}) \times \\
 &\quad \times \chi_R(T_{p'}^{(m+n)}) \chi_{R_1}(T_{q'_1}^{(m)}) \chi_{R_2}(T_{q'_2}^{(n)}) \chi_R(T_{p''}^{(m+n)}) \chi_{R_1}(T_{q''_1}^{(m)}) \chi_{R_2}(T_{q''_2}^{(n)}) \quad (4.2.42)
 \end{aligned}$$

More generally, we can use (4.2.41) to compute the identity coefficient of an arbitrary large products of central elements, $\delta(Z_a Z_b \cdots Z_k)$, just by using ordinary symmetric group characters.

4.2.2 Maximal commuting subalgebra

In this section we describe the Maximal commuting subalgebra $\mathcal{M}(m, n)$ of $\mathcal{A}(m, n)$:

$$\mathcal{Z}(m, n) \subseteq \mathcal{M}(m, n) \subseteq \mathcal{A}(m, n) \quad (4.2.43)$$

We often refer to $\mathcal{M}(m, n)$ as the Cartan subalgebra of $\mathcal{A}(m, n)$. $\mathcal{M}(m, n)$ is spanned by elements of the form $Q_{R_1, R_2, i, i}^R$ (no sum over i). For fixed R_1, R_2 and R , the total number of basis elements is $g(R_1, R_2; R)$, so that its dimension is

$$|\mathcal{M}(m, n)| = \sum_{\substack{R_1 \vdash m, R_2 \vdash n \\ R \vdash m+n}} g(R_1, R_2; R) \quad (4.2.44)$$

In Appendix C.1 we derived the dimension formula

$$|\mathcal{M}(m, n)| = \sum_{p \vdash m} \sum_{q \vdash n} \mathcal{F}_p \mathcal{F}_q \mathcal{F}_{p+q} \text{Sym}(p+q) \quad (4.2.45)$$

where p, q are partitions of m and n , $\mathcal{F}_p, \mathcal{F}_q, \mathcal{F}_{p+q}$ are combinatorial quantities dependent only on the partitions p, q and $p+q$ respectively, and $\text{Sym}(p+q) = \prod_i i^{p_i+q_i} (p_i+q_i)!$ is a symmetry factor.

We now turn to the problem of constructing a basis for $\mathcal{M}(m, n)$. According to the definition (4.2.9), to write the basis elements $Q_{R_1, R_2, i, i}^R$ we first need to compute the branching coefficients for the branching $R \rightarrow R_1 \otimes R_2$. These quantities are in general computationally hard to obtain⁵, and require a choice of a basis in S_{m+n} representations adapted to $S_m \times S_n$. However, using the correspondence with matrix algebras given by the Wedderburn-Artin decomposition, we can construct the Cartan by solving, in each block, the following equations for $(g(R_1, R_2; R) - 1)$

⁵see for example a discussion of the difficulty and the simplifications in a ‘‘distant corners approximation’’ in [35]

linearly independent elements $Q_{R_1, R_2, a}^R \in \mathcal{A}(m, n)$

$$P_{R_1, R_2}^R Q_{R_1, R_2, a}^R = Q_{R_1, R_2, a}^R \quad (4.2.46a)$$

$$\langle P_{R_1, R_2}^R, Q_{R_1, R_2, a}^R \rangle = 0 \quad (4.2.46b)$$

$$[Q_{R_1, R_2, a}^R, Q_{R_1, R_2, b}^R] = 0 \quad (4.2.46c)$$

In the second equation, we are using the pairing defined in (4.2.4).

4.3 Star product for composite operators

In the previous sections we discussed the algebra $\mathcal{A}(m, n)$ and its centre $\mathcal{Z}(m, n)$. We noted that central elements are special, as all their properties only depend on ordinary symmetric group character theory. An example of this is eq. (4.2.42). In this section we will take advantage of this fact to compute physically relevant quantities, in particular two and three point functions of BPS operators in $\mathcal{N} = 4$ SYM. To do so, we will first start by discussing the one matrix sector in $\mathcal{N} = 4$ SYM, reviewing the permutation description of $U(N)$ matrix invariants which are Gauge Invariants Operators (GIOs) in the conformal field theory. We will stress that for this case there is an underlying $\mathcal{Z}[\mathbb{C}[S_n]]$ algebra. The one matrix problem will be used as a guide to extend to the two matrix problem, that we treat in subsection 4.3.2. Here the underlying algebra will be $\mathcal{A}(m, n)$.

4.3.1 One matrix problem

Let us consider a matrix invariant constructed with n copies of the same matrix Z . Any such invariant can be written in terms of a contraction

$$\mathcal{O}_\sigma(Z) = \text{tr} (Z^{\otimes n} \sigma) , \quad \sigma \in S_n \quad (4.3.1)$$

subject to the equivalence relation

$$\mathcal{O}_\sigma(Z) = \mathcal{O}_{\gamma^{-1}\sigma\gamma}(Z) , \quad \gamma \in S_n \quad (4.3.2)$$

Polynomials in Z like the one in (4.3.1) can be multiplied together. Set $\sigma_1 \in S_{n_1}$, $\sigma_2 \in S_{n_2}$. By multiplying together $\mathcal{O}_{\sigma_1}(Z)$ and $\mathcal{O}_{\sigma_2}(Z)$ we get

$$\mathcal{O}_{\sigma_1}(Z) \mathcal{O}_{\sigma_2}(Z) = \mathcal{O}_{\sigma_1 \circ \sigma_2}(Z) \quad (4.3.3)$$

where $\sigma_1 \circ \sigma_2 \in S_{n_1} \times S_{n_2} \subset S_{n_1+n_2}$. Therefore for the usual product of matrix invariants, $\sigma_1 \circ \sigma_2$ lives in the symmetric group of degree $n_1 + n_2$. We can define

$$\mathbb{C}[S_\infty] = \bigoplus_n \mathbb{C}[S_n] \quad (4.3.4)$$

which is closed under the circle product

$$\circ : \mathbb{C}[S_\infty] \otimes \mathbb{C}[S_\infty] \rightarrow \mathbb{C}[S_\infty] \quad (4.3.5)$$

However, we can define another associative product, that we call *star product*, which closes on the operators of fixed degree:

$$\mathcal{O}_{\sigma_1}(Z) * \mathcal{O}_{\sigma_2}(Z) = \mathcal{O}_{\sigma_1\sigma_2}(Z), \quad \sigma_{1,2} \in S_n \quad (4.3.6)$$

It is immediate to see how this product is different from the ordinary GIO multiplication product (4.3.3): σ_1 , σ_2 and $\sigma_1\sigma_2$ are all permutations of n elements, and the star product is generally non-commutative. Let $[\sigma]$ be the conjugacy class of σ . We now define a map from the multi-trace GIOs to the class-algebra

$$\mathcal{O}_\sigma(Z) \rightarrow \frac{1}{\text{size of } [\sigma]} \sum_{\tau \in [\sigma]} \tau \equiv \frac{T_\sigma}{|T_\sigma|} \quad (4.3.7)$$

This map is 1-1 at large N . Let us focus on this case. We can expand the product of $T_i, T_j \in \mathcal{Z}[\mathbb{C}[S_n]]$ as

$$T_i T_j = C_{ij}^k T_k \quad (4.3.8)$$

Here the C_{ij}^k are the class algebra structure constants. By multiplying both sides above by T_l and taking the coefficient of the identity we get

$$\delta(T_i T_j T_l) = C_{ij}^k \delta(T_k T_l) = \delta_{k,l} C_{ij}^k |T_l| = C_{ij}^k |T_k| \quad (4.3.9)$$

Now we expand the star product $\mathcal{O}_{\sigma_1}(Z) * \mathcal{O}_{\sigma_2}(Z)$ as

$$\mathcal{O}_{\sigma_1}(Z) * \mathcal{O}_{\sigma_2}(Z) = \sum_p \frac{|T_{\sigma_p}|}{|T_{\sigma_1}| |T_{\sigma_2}|} C_{[\sigma_1][\sigma_2]}^p \mathcal{O}_{\sigma_p}(Z) = \sum_p \frac{\delta(T_{\sigma_1} T_{\sigma_2} T_{\sigma_p})}{|T_{\sigma_1}| |T_{\sigma_2}|} \mathcal{O}_{\sigma_p}(Z) \quad (4.3.10)$$

where the sum is over the conjugacy classes p of S_n . σ_p is a representative element of the conjugacy class p . This equation will lead to a new expression for the two point functions of GIOs built from Z, Z^\dagger in $\mathcal{N} = 4$ SYM. First observe that setting Z to the identity $N \times N$ matrix

$$\mathcal{O}_\sigma(Z = 1_N) = N^{C_\sigma} \quad (4.3.11)$$

where C_σ is the number of cycles in the permutation σ . Now consider taking the star product

of $\mathcal{O}_{\sigma_1}(Z)$, $\mathcal{O}_{\sigma_2}(Z)$ and then setting $Z = 1_N$. We have, according to (4.3.10)

$$\begin{aligned} \mathcal{O}_{\sigma_1}(Z) * \mathcal{O}_{\sigma_2}(Z) \Big|_{Z=1_N} &= \frac{1}{|T_{\sigma_1}| |T_{\sigma_2}|} \sum_p \delta(T_{\sigma_1} T_{\sigma_2} T_{\sigma_p}) \mathcal{O}_{\sigma_p}(1_N) \\ &= \frac{1}{|T_{\sigma_1}| |T_{\sigma_2}|} \sum_p \delta(T_{\sigma_1} T_{\sigma_2} T_{\sigma_p}) N^{C_{\sigma_p}} = \frac{1}{n! |T_{\sigma_1}| |T_{\sigma_2}|} \sum_{\gamma \in S_n} \delta(\gamma T_{\sigma_1} \gamma^{-1} T_{\sigma_2} \Omega) \end{aligned} \quad (4.3.12)$$

where we set $\Omega = \sum_p T_{\sigma_p} N^{C_{\sigma_p}}$. On the other hand the free field correlator, already discussed at the end of Section 1.2.1, is known to be [17]

$$\left\langle \mathcal{O}_{\sigma_1}(Z) \mathcal{O}_{\sigma_2}^\dagger(Z) \right\rangle = \frac{1}{|T_{\sigma_1}| |T_{\sigma_2}|} \sum_{\gamma \in S_n} \delta(\gamma T_{\sigma_1} \gamma^{-1} T_{\sigma_2} \Omega) \quad (4.3.13)$$

so that

$$\left\langle \mathcal{O}_{\sigma_1}(Z) \mathcal{O}_{\sigma_2}^\dagger(Z) \right\rangle = n! \mathcal{O}_{\sigma_1}(Z) * \mathcal{O}_{\sigma_2}(Z) \Big|_{Z=1_N} \quad (4.3.14)$$

The two point function $\left\langle \mathcal{O}_{\sigma_1}(Z) \mathcal{O}_{\sigma_2}^\dagger(Z) \right\rangle$ is therefore proportional to the star product $\mathcal{O}_{\sigma_1}(Z) * \mathcal{O}_{\sigma_2}(Z)$ followed by the evaluation $Z \rightarrow 1_N$.

Similar considerations lead to the following expression for the extremal three point function. In this case, we find that $\left\langle \mathcal{O}_{\sigma_1}(Z) \mathcal{O}_{\sigma_2}(Z) \mathcal{O}_{\sigma_3}^\dagger(Z) \right\rangle$ is proportional to the usual product $\mathcal{O}_{\sigma_1}(Z) \mathcal{O}_{\sigma_2}(Z)$, followed by the star product with $\mathcal{O}_{\sigma_3}(Z)$, followed by the evaluation $Z \rightarrow 1_N$. To see this, take $\sigma_1 \in S_{n_1}$, $\sigma_2 \in S_{n_2}$ and consider

$$(\mathcal{O}_{\sigma_1}(Z) \mathcal{O}_{\sigma_2}(Z)) * \mathcal{O}_{\sigma_3}(Z) \Big|_{Z=1_N} = \frac{1}{|T_{\sigma_1 \circ \sigma_2}| |T_{\sigma_3}|} \delta(T_{\sigma_1 \circ \sigma_2} T_{\sigma_3} \Omega) \quad (4.3.15)$$

where $T_{\sigma_1 \circ \sigma_2} \in \mathcal{Z}[\mathbb{C}[S_{n_1+n_2}]]$, $T_{\sigma_3} \in \mathcal{Z}[\mathbb{C}[S_{n_1+n_2}]]$ and $\Omega = \sum_{\sigma \in S_{n_1+n_2}} \sigma N^{C_\sigma}$. On the other hand the correlator in $\mathcal{N} = 4$ SYM [17] is

$$\left\langle \mathcal{O}_{\sigma_1}(Z) \mathcal{O}_{\sigma_2}(Z) \mathcal{O}_{\sigma_3}^\dagger(Z) \right\rangle = \sum_{\gamma \in S_{n_1+n_2}} \delta(\gamma(\sigma_1 \circ \sigma_2) \gamma^{-1} \sigma_3^{-1} \Omega) = \frac{(n_1 + n_2)!}{|T_{\sigma_1 \circ \sigma_2}| |T_{\sigma_3}|} \delta(T_{\sigma_1 \circ \sigma_2} T_{\sigma_3} \Omega) \quad (4.3.16)$$

so that

$$\left\langle \mathcal{O}_{\sigma_1}(Z) \mathcal{O}_{\sigma_2}(Z) \mathcal{O}_{\sigma_3}^\dagger(Z) \right\rangle = (n_1 + n_2)! (\mathcal{O}_{\sigma_1 \circ \sigma_2}(Z)) * \mathcal{O}_{\sigma_3}(Z) \Big|_{Z=1_N} \quad (4.3.17)$$

Given that these correlators are neatly expressed in terms of the star product, it would be interesting to give an interpretation of the latter in the dual $AdS_5 \times S_5$ side.

We will now write similar equations for the two matrix problem.

4.3.2 Two matrix problem

For the two matrix problem, the GIOs are polynomials in the X, Y matrices. Formally, we can write them in terms of a permutation $\sigma \in S_{m+n}$ as

$$\mathcal{O}_\sigma(X, Y) = \text{Tr}(X^{\otimes m} \otimes Y^{\otimes n} \sigma) \quad (4.3.18)$$

As in the one matrix problem, there is an equivalence relation

$$\mathcal{O}_\sigma(X, Y) = \mathcal{O}_{\gamma\sigma\gamma^{-1}}(X, Y), \quad \gamma \in S_m \times S_n \quad (4.3.19)$$

To each of these GIO \mathcal{O}_σ we can associate a specific element N_σ of $\mathcal{A}(m, n)$ that we call a necklace. We define a necklace N_σ as

$$N_\sigma = \frac{1}{|\text{Aut}_{S_m \times S_n}(\sigma)|} \sum_{\gamma \in S_m \times S_n} \gamma\sigma\gamma^{-1} \quad (4.3.20)$$

or equivalently as

$$N_\sigma = \sum_{\tau \in \text{Orbit}(\sigma, S_m \times S_n)} \tau \quad (4.3.21)$$

where the sum is restricted to the permutations τ in the group orbit of σ under $S_m \times S_n$. We can think of the necklaces as the normalised version of the $\bar{\sigma}$ elements defined in (4.2.3). The set of necklaces form a basis for $\mathcal{A}(m, n)$. We associate a GIO to a necklace simply by mapping

$$\mathcal{O}_\sigma(X, Y) \rightarrow \frac{1}{|N_\sigma|} N_\sigma \quad (4.3.22)$$

For example, for the GIO corresponding to the permutation $\tilde{\sigma} = (1, 2, 4, 5)(3, 6) \in S_6$:

$$\mathcal{O}_{\tilde{\sigma}}(X, Y) = \text{Tr}(X^2 Y^2) \text{Tr}(XY) \quad (4.3.23)$$

we associate, through the map (4.3.22), the $\mathcal{A}(3, 3)$ element

$$N_{\tilde{\sigma}} = \sum_{S_3 \times S_3} \gamma \tilde{\sigma} \gamma^{-1} = \sum_{\substack{a_1 \neq a_2 \neq a_3 \in \{1, 2, 3\} \\ \bar{b}_1 \neq \bar{b}_2 \neq \bar{b}_3 \in \{4, 5, 6\}}} (a_1, a_2, \bar{b}_1, \bar{b}_2)(a_3, \bar{b}_3) \quad (4.3.24)$$

Similarly, for the GIO specified by $\tilde{\sigma} = (1, 2, 3) \in S_6$

$$\mathcal{O}_{\tilde{\sigma}}(X, Y) = \text{Tr}(X^2 Y) \text{Tr}(Y)^3 \quad (4.3.25)$$

we associate the $\mathcal{A}(2, 4)$ necklace

$$N_{\tilde{\sigma}} = \sum_{\substack{a_1 \neq a_2 \in \{1, 2\} \\ \bar{b}_1 \in \{3, 4, 5, 6\}}} (a_1, a_2, \bar{b}_1) \quad (4.3.26)$$

Notice that in the necklaces we do not explicitly write the single cycle permutations, but rather we leave them implicit. In the last example, these single cycle permutations would account for the multi-trace $\text{Tr}(Y)^3$ component of $\mathcal{O}_{\tilde{\sigma}} = \text{Tr}(X^2Y)\text{Tr}(Y)^3$.

From these examples it is clear how these necklaces are built by taking products of cyclic objects, which in turn are constructed using two different types of *beads*. Such cyclic objects are well studied in Polya theory. They can be related to the single cycle permutations in S_{m+n} with equivalences generated by $S_m \times S_n$. These equivalence classes form the algebra $\mathcal{A}(m, n)$. We can imagine having blue beads corresponding to integers $[1, 2, \dots, m]$ and red beads corresponding to integers $[m+1, m+2, \dots, m+n]$. Therefore, we can pictorially depict the necklaces of examples (4.3.24) and (4.3.26) as in figure 41. The same structure is present in the GIO \mathcal{O}_{σ} corresponding to the necklace N_{σ} . In this case the single-traces are the cyclic objects, and the role of the blue and red beads is played by the X and Y type fields respectively.

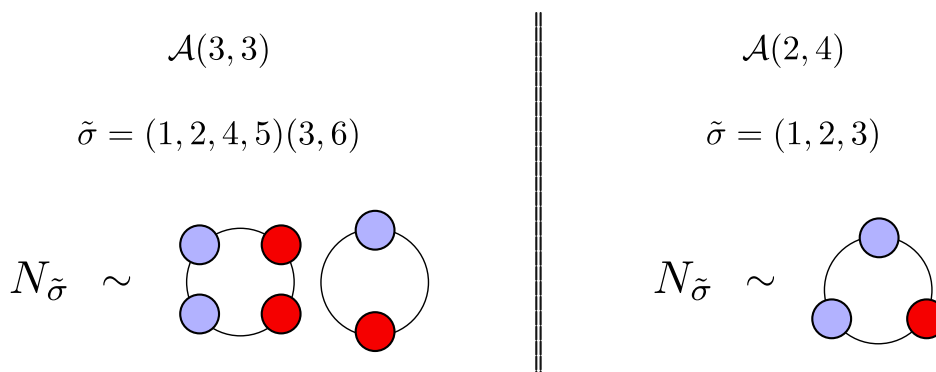

Figure 41: Pictorial interpretations of the necklaces in the examples (4.3.24) and (4.3.26).

The map (4.3.22) is 1-1 at large N : as in the 1-matrix problem, we now focus on this case. There is a natural product on the space of two matrix GIOs coming from multiplying the multi-traces. For such a product, the degrees of the permutations add:

$$\mathcal{O}_{\sigma_1}(X, Y)\mathcal{O}_{\sigma_2}(X, Y) = \mathcal{O}_{\sigma_1 \circ \sigma_2}(X, Y) \quad (4.3.27)$$

Here $\sigma_1 \in S_{m_1+n_1}$ is a representative of a class in $\mathcal{A}(m_1, n_1)$ and $\sigma_2 \in S_{m_2+n_2}$ represents a class in $\mathcal{A}(m_2, n_2)$, while $\sigma_1 \circ \sigma_2 \in S_{m_1+n_1} \times S_{m_2+n_2} \subset S_{m_1+m_2+n_1+n_2}$ represents a class in $\mathcal{A}(m_1+m_2, n_1+n_2)$. Continuing the analogy with (4.3.4), we can define

$$\mathcal{A}(\infty, \infty) = \bigoplus_{m,n} \mathcal{A}(m, n) \quad (4.3.28)$$

and for $\bar{\sigma}_1 \in \mathcal{A}(m_1, n_1)$ and $\bar{\sigma}_2 \in \mathcal{A}(m_2, n_2)$ we have

$$\circ : \mathcal{A}(\infty, \infty) \otimes \mathcal{A}(\infty, \infty) \rightarrow \mathcal{A}(\infty, \infty) \quad (4.3.29)$$

As in the one matrix case, there is however a second type of product of GIOs that we can

construct. The product on $\mathcal{A}(m, n)$ can in fact be used to define a closed and associative star product on the space of the multi-trace operators with fixed numbers (m, n) of (X, Y) , in the same fashion as (4.3.6):

$$\mathcal{O}_{\bar{\sigma}_1}(X, Y) * \mathcal{O}_{\bar{\sigma}_2}(X, Y) = \mathcal{O}_{\bar{\sigma}_1 \bar{\sigma}_2}(X, Y), \quad \bar{\sigma}_{1,2} \in \mathcal{A}(m, n) \quad (4.3.30)$$

Notice that here $\bar{\sigma}_1$, $\bar{\sigma}_2$ and $\bar{\sigma}_1 \bar{\sigma}_2$ are all of the same degree, and that the star product is non-commutative. We will use this star product to express the two point function of GIOs built from X, Y .

Since the set of necklaces $\{N_a\}$ forms a basis for $\mathcal{A}(m, n)$, we can expand the product $N_a N_b$ as

$$N_a N_b = C_{a,b}^c N_c \quad (4.3.31)$$

for some structure constants $C_{a,b}^c$. Moreover, the necklaces are orthogonal in the metric (4.2.4):

$$\langle N_a, N_b \rangle = \delta(N_a N_b) = \delta_{a,b} |N_b| \quad (4.3.32)$$

Here $|N_a|$ is the number of permutations in the necklace N_a . We can write

$$\delta(N_a N_b N_c) = |N_c| C_{a,b}^c \quad (4.3.33)$$

Now use the map (4.3.22) to map the two matrix invariants $\mathcal{O}_a(X, Y)$ and $\mathcal{O}_b(X, Y)$ to the necklaces N_a and N_b respectively. Then

$$\mathcal{O}_a(X, Y) * \mathcal{O}_b(X, Y) = \sum_c C_{a,b}^c \frac{|N_c|}{|N_a| |N_b|} \mathcal{O}_c(X, Y) = \sum_c \frac{1}{|N_a| |N_b|} \delta(N_a N_b N_c) \mathcal{O}_c(X, Y) \quad (4.3.34)$$

As for the one matrix problem case, by setting $X = Y = 1_N$ we get

$$\mathcal{O}_a(X, Y) * \mathcal{O}_b(X, Y) \Big|_{X=Y=1_N} = \frac{1}{|N_a| |N_b|} \delta(N_a N_b \Omega) \quad (4.3.35)$$

where $\Omega = \sum_{\sigma \in S_{m+n}} \sigma N^{C_\sigma}$. On the other hand the free field correlator [18, 30] is

$$\begin{aligned} \langle \mathcal{O}_a(X, Y) \mathcal{O}_b^\dagger(X, Y) \rangle &= \sum_{\gamma \in S_m \times S_n} \delta(\gamma a \gamma^{-1} b^{-1} \Omega) = \frac{1}{|N_a| |N_b|} \sum_{\gamma \in S_m \times S_n} \delta(\gamma N_a \gamma^{-1} N_b \Omega) \\ &= \frac{m! n!}{|N_a| |N_b|} \delta(N_a N_b \Omega) \end{aligned} \quad (4.3.36)$$

Therefore, in analogy with (4.3.14) and (4.3.17), we can write the two point function as

$$\langle \mathcal{O}_a(X, Y) \mathcal{O}_b^\dagger(X, Y) \rangle = m! n! \mathcal{O}_a(X, Y) * \mathcal{O}_b(X, Y) \Big|_{X=Y=1_N} \quad (4.3.37)$$

and the extremal three point function as

$$\left\langle \mathcal{O}_a(X, Y) \mathcal{O}_b(X, Y) \mathcal{O}_c^\dagger(X, Y) \right\rangle = (m_1 + m_2)! (n_1 + n_2)! \mathcal{O}_{aob}(X, Y) * \mathcal{O}_c(X, Y) \Big|_{X=Y=1_N} \quad (4.3.38)$$

where $a \in S_{m_1+n_1}$, $b \in S_{m_2+n_2}$ and $c \in S_{m_1+n_1+m_2+n_2}$. Finally, notice that the pairing (4.2.4) is proportional to the planar correlator [89–91] of BPS operators: given $\mathcal{O}_a(X, Y)$ and $\mathcal{O}_b(X, Y)$, we have

$$\left\langle \mathcal{O}_a(X, Y) \mathcal{O}_b^\dagger(X, Y) \right\rangle_{\text{planar}} = m!n! \langle a, b \rangle \quad (4.3.39)$$

where the pairing on the RHS is the one in eq. (4.2.4).

Let us now focus on the centre of $\mathcal{A}(m, n)$. In section 4.2 we argued that the centre is generated by $\{T_p^{(m+n)}, T_{q_1}^{(m)}, T_{q_2}^{(n)}\}$. We remind the reader that $\{T_p^{(m+n)}\}$, $\{T_{q_1}^{(m)}\}$ and $\{T_{q_2}^{(n)}\}$ are the generators of the centres of $\mathbb{C}[S_{m+n}]$, $\mathbb{C}[S_m]$ and $\mathbb{C}[S_n]$ respectively, and that p , q_1 and q_2 are integer partitions of $m+n$, m and n . A GIO $\mathcal{O}_{T_p^{(m+n)}}(X, Y)$ can be understood as a descendant of a single matrix $1/2$ BPS state $\mathcal{O}_{T_p^{(m+n)}}(X)$ under the $U(2)$ internal symmetry that mixes the X and Y fields. In fact, given $(D^-)_j^i = Y_k^i \frac{\partial}{\partial X_k^j}$: we can write

$$\mathcal{O}_{T_p^{(m+n)}}(X, Y) \sim (D^-)^n \mathcal{O}_{T_p^{(m+n)}}(X) \quad (4.3.40)$$

This means that central elements (and their corresponding matrix gauge invariants), described in terms of the over-complete basis $\{T_p^{(m+n)}, T_{q_1}^{(m)}, T_{q_2}^{(n)}\}$, are formed from composites which employ both the usual product and the star product :

$$[\text{Descendant Operators}] * \{(X\text{-Operators}) (Y\text{-Operators})\} \quad (4.3.41)$$

The descendant GIOs are associated to $T_p^{(m+n)}$ elements, X - and Y - GIOs to $T_{q_1}^{(m)}$ and $T_{q_2}^{(n)}$ elements respectively. In terms of the permutations we are taking the product in $\mathcal{A}(m, n)$ along with the circle product $\circ : \mathcal{A}(m, 0) \otimes \mathcal{A}(0, n) \rightarrow \mathcal{A}(m, n)$.

Single-trace symmetrised traces are $U(2)$ descendants of single-trace operators built from a single matrix. In terms of the permutation language, they correspond to single-cycle permutations which are invariant under any reshuffling⁶. On the other hand, $U(2)$ descendants of multi-trace operators built from one matrix form a subspace of the space spanned by products of symmetrised single-trace states. In other words, not all products of single-trace descendants are themselves descendants. One way to see this explicitly is the following. Let $ST_{m,n}$ be the space of symmetrised traces with m copies of X and n copies of Y matrices. The generating

⁶Further details of symmetrised traces in terms of an operation on the permutations in the $\mathcal{O}_\sigma(X, Y)$ can be found in [91].

function for the dimension $\text{Dim}(ST_{m,n})$ is

$$\prod_{i,j \in \Omega} \frac{1}{1 - x^i y^j} = \sum_{m,n} \text{Dim}(ST_{m,n}) x^m y^n \quad (4.3.42)$$

where $\Omega = \{0 \leq i \leq \infty\} \cup \{0 \leq j \leq \infty\} \setminus \{i = j = 0\}$. Let ST_{m+n} be the space of symmetrised traces with a total of $m + n$ matrices, with any number of X or Y . We have

$$\text{Dim}(ST_{m+n}) = \sum_{i=0}^{m+n} \text{Dim}(ST_{i,m+n-i}) \quad (4.3.43)$$

On the other hand, the total number of $U(2)$ descendants obtained from a multi-trace operator with $m + n$ copies of X is

$$(m + n + 1) p(m + n) \quad (4.3.44)$$

$p(m + n)$ is the number of partitions of $m + n$ (the number of highest weight states), while $m + n + 1$ is the number of descendants for a fixed highest weight. It can now be checked that $\text{Dim}(ST_{m+n}) > p(m + n)(m + n + 1)$. This indeed proves our original claim.

4.3.3 Cartan subalgebra and the minimal set of charges

In [54], it was observed that, in the free limit, multi-matrix gauge theories have enhanced symmetries including products of unitary groups. There are Noether charges for these enhanced symmetries. Casimirs constructed from these charges have eigenvalues which can distinguish all the labels R, R_1, R_2, i, j of restricted Schur operators. Because of Schur-Weyl duality, these charges are also expressible in terms of permutations. Given the definitions in this chapter, this action of permutations amounts to the action of $\mathcal{A}(m, n)$ on itself by the left or right regular representation. We can now characterize more precisely what is a minimal set of charges which can measure all the labels. In section 4.2.2 we introduced the Cartan subalgebra $\mathcal{M}(m, n)$, and gave a prescription to build a basis for it. We need to find a subspace $C_{m,n}$ of $\mathcal{M}(m, n)$ such that polynomials in some basis elements $c_a \in C_{m,n}$ with coefficients taking values in the centre $\mathcal{Z}(m, n)$ span $\mathcal{M}(m, n)$. In other words $C_{m,n}$ contains a minimal set of generators for $\mathcal{M}(m, n)$ as a polynomial algebra over $\mathcal{Z}(m, n)$. A minimal set of generators for $\mathcal{Z}(m, n)$, along with the basis elements of the subspace $C_{m,n}$, provide a complete set of charges, which can measure all the labels of the $Q_{R_1, R_2, i, j}^R$ by left and right multiplication. Let $N^{\min}(\mathcal{Z}(m, n))$ be the minimal number of elements of $\mathcal{Z}(m, n)$ which generate $\mathcal{Z}(m, n)$ as a polynomial algebra. Also, let $N_{\mathcal{Z}(m, n)}^{\min}(\mathcal{M}(m, n))$ be the minimal number of elements of $\mathcal{M}(m, n)$ which generate $\mathcal{M}(m, n)$ as a polynomial algebra over $\mathcal{Z}(m, n)$. Left multiplication by these generators correspond to enhanced symmetry charges which measure the multiplicity index i of restricted Schur operators. Right multiplication by the same generators correspond to other enhanced symmetry charges which measure the multiplicity index j of restricted Schur operators. Hence the minimal number

of charges is

$$N^{\min}(\mathcal{Z}(m, n)) + 2N_{\mathcal{Z}(m, n)}^{\min}(\mathcal{M}(m, n)) \quad (4.3.45)$$

An *important open problem* is to determine this function of (m, n) in general. This will tell us how many bits of information completely specify all the operators in a multi-matrix set-up.

The above discussion is complete for the case where $m + n < N$, which is adequate for a treatment of the physics at all orders in the $1/N$ expansion. For finite N effects, where we consider $m + n > N$, the charges given by the above still determine all the multi-matrix invariants, but they are not a minimal set any more. The discussion can be easily adapted to this case. Define

$$\mathcal{A}_N^{\text{null}}(m, n) = \bigoplus_{R \vdash m+n: c_1(R) > N} \bigoplus_{R_1 \vdash m, R_2 \vdash n} \text{Span}\{Q_{R_1, R_2, i, j}^R; i, j\} \quad (4.3.46)$$

The quotient

$$\mathcal{A}_N(m, n) = \mathcal{A}(m, n) / \mathcal{A}_N^{\text{null}}(m, n) \quad (4.3.47)$$

is a closed sub-algebra of blocks surviving the finite N cut. It has a centre $\mathcal{Z}_N(m, n)$ and a Cartan $\mathcal{M}_N(m, n)$ which are simply related to $\mathcal{Z}(m, n)$ and $\mathcal{M}(m, n)$ by quotienting out the parts belonging to $\mathcal{A}_N^{\text{null}}(m, n)$. Let $N^{\min}(\mathcal{Z}_N(m, n))$ be the number of generators in a minimal generating set for $\mathcal{Z}_N(m, n)$ as a polynomial algebra. Let $N_{\mathcal{Z}_N(m, n)}^{\min}(\mathcal{M}_N(m, n))$ be the number of generators in a minimal generating set for $\mathcal{M}_N(m, n)$ as a polynomial algebra over $\mathcal{Z}_N(m, n)$. The minimal number of charges needed is

$$N^{\min}(\mathcal{Z}_N(m, n)) + 2N_{\mathcal{Z}_N(m, n)}^{\min}(\mathcal{M}_N(m, n)) \quad (4.3.48)$$

We expect (4.3.45), (4.3.48) will have implications for information theoretic discussions of AdS/CFT such as [92, 93].

4.4 Computation of the finite N correlator

In this section we will derive a finite N generating function for the two point function of operators of the form

$$\mathcal{O} = \text{Tr}(X^m Y^n) \quad (4.4.1)$$

in the free field metric. Operators like the one in (4.4.1) correspond to $\mathcal{A}(m, n)$ elements

$$\frac{1}{m!n!} T_{1,1} T_{[m]}^{(X)} T_{[n]}^{(Y)} \quad (4.4.2)$$

where $T_{\bar{1},1} = T_2^{(X,Y)} - T_2^{(X)} - T_2^{(Y)}$. Here $T_2^{(X,Y)}$, $T_2^{(X)}$ and $T_2^{(Y)}$ are the sum of transpositions in S_{m+n} , S_m and S_n respectively. $T_{\bar{1},1}$ can be understood as a joining operator, merging the $(1 \cdots m)$ type cycles with the $(m+1 \cdots m+n)$ type cycles.

The two point function (4.3.36) therefore reads, with $\mathcal{O} = \text{Tr}(X^m Y^n)$

$$\begin{aligned} \langle \mathcal{O} \mathcal{O}^\dagger \rangle &= \frac{1}{m!^2 n!^2} \sum_{\gamma \in S_m \times S_n} \sum_{\sigma \in S_{m+n}} \delta \left(\gamma T_{\bar{1},1} T_{[m]}^{(X)} T_{[n]}^{(Y)} \gamma^{-1} T_{\bar{1},1} T_{[m]}^{(X)} T_{[n]}^{(Y)} \sigma \right) N^{C_\sigma} \\ &= \frac{1}{m!n!} \delta \left(T_{\bar{1},1} T_{[m]}^{(X)} T_{[n]}^{(Y)} T_{\bar{1},1} T_{[m]}^{(X)} T_{[n]}^{(Y)} \Omega \right) \end{aligned} \quad (4.4.3)$$

where we set $\Omega = \sum_{\sigma \in S_{m+n}} \sigma N^{C_\sigma}$. This quantity can be computed using only ordinary character theory. Using eq. (4.2.42) and using the shorthand notation $g = g(R_1, R_2; R)$ we write

$$\langle \mathcal{O} \mathcal{O}^\dagger \rangle = \frac{1}{(m+n)!m!n!} \sum_{\substack{R_1 \vdash m \\ R_2 \vdash n}} \sum_{R \vdash m+n} \frac{d_R}{d_{R_1}^2 d_{R_2}^2 g^2} \left(\chi_{R_1, R_2}^R \left(T_{\bar{1},1} T_{[m]}^{(X)} T_{[n]}^{(Y)} \right) \right)^2 \chi_{R_1, R_2}^R(\Omega) \quad (4.4.4)$$

We now expand $T_{\bar{1},1} = T_2^{(X,Y)} - T_2^{(X)} - T_2^{(Y)}$ so that

$$T_{\bar{1},1} T_{[m]}^{(X)} T_{[n]}^{(Y)} = T_2^{(X,Y)} T_{[m]}^{(X)} T_{[n]}^{(Y)} - T_2^{(X)} T_{[m]}^{(X)} T_{[n]}^{(Y)} - T_{[m]}^{(X)} T_2^{(Y)} T_{[n]}^{(Y)} \quad (4.4.5)$$

We also have (see *e.g.* [26])

$$\chi_{R_1, R_2}^R(\Omega) = \chi_{R_1, R_2}^R \left(\sum_{\sigma \in S_{m+n}} \sigma N^{C_\sigma} \right) = \frac{g d_{R_1} d_{R_2}}{d_R} (n+m)! \text{Dim}_N(R) \quad (4.4.6)$$

Eq. (4.4.4) simplifies then to

$$\langle \mathcal{O} \mathcal{O}^\dagger \rangle = \frac{1}{m!n!} \sum_{\substack{R_1 \vdash m \\ R_2 \vdash n}} \sum_{R \vdash m+n} \frac{1}{d_{R_1} d_{R_2} g} \text{Dim}_N(R) \left(\chi_{R_1, R_2}^R \left(T_{\bar{1},1} T_{[m]}^{(X)} T_{[n]}^{(Y)} \right) \right)^2 \quad (4.4.7)$$

On the other hand, as shown in Appendix C.3

$$\begin{aligned} \chi_{R_1, R_2}^R \left(T_{\bar{1},1} T_{[m]}^{(X)} T_{[n]}^{(Y)} \right) &= \\ &= \begin{cases} (-1)^{c_{R_1} + c_{R_2}} g (m-1)! (n-1)! \left[\frac{\chi_R(T_2^{(X,Y)})}{d_R} - \frac{\chi_{R_1}(T_2^{(X)})}{d_{R_1}} - \frac{\chi_{R_2}(T_2^{(Y)})}{d_{R_2}} \right]; & R_1, R_2 \text{ hooks} \\ 0 & \text{otherwise} \end{cases} \end{aligned}$$

Here c_{R_i} is the number of boxes in the first column of the Young diagram associated with the representation R_i . This expression restricts the sums over representations $R_1 \vdash m$, $R_2 \vdash n$ in (4.4.7) to a sum over hook representations $h_1 \vdash m$, $h_2 \vdash n$.

We now need an equation for $g(h_1, h_2; R)$, with h_1 and h_2 hook representations of S_m and S_n respectively. We specify any representation R by the sequence of pairs of integers $R =$

$((a_1, b_1), (a_2, b_2), \dots, (a_d, b_d))$. In a Young diagram interpretation, a_j ($1 \leq j \leq d$) is the number of boxes to the right of the j -th diagonal box, and b_j is the number of boxes below the j -th diagonal box. We refer to d as the ‘depth’ of the representation R . Let us write $h_1 = (k_1, l_1)$, $h_2 = (k_2, l_2)$ and $R = ((a_1, b_1), (a_2, b_2))$. In Appendix C.2 we show that

$$\begin{aligned}
 g(h_1, h_2; R) &= \delta_{k_1+k_2, a_1} \delta_{l_1+l_2+1, b_1} \delta_{-1, a_2} \delta_{0, b_2} + \delta_{k_1+k_2+1, a_1} \delta_{l_1+l_2, b_1} \delta_{0, a_2} \delta_{-1, b_2} \\
 &+ \sum_{\epsilon_1, \epsilon_2=0}^1 \sum_{i=\epsilon_1 \bar{\epsilon}_2}^{\min(k_1 - \bar{\epsilon}_1 \bar{\epsilon}_2, k_2 - \epsilon_1 \epsilon_2)} \sum_{j=\bar{\epsilon}_1 \epsilon_2}^{\min(l_1 - \bar{\epsilon}_1 \bar{\epsilon}_2, l_2 - \epsilon_1 \epsilon_2)} \delta_{k_1+k_2-i+\bar{\epsilon}_1 \epsilon_2, a_1} \delta_{l_1+l_2-j+\bar{\epsilon}_1 \bar{\epsilon}_2, b_1} \delta_{i-\bar{\epsilon}_1 \bar{\epsilon}_2, a_2} \delta_{j-\bar{\epsilon}_1 \bar{\epsilon}_2, b_2}
 \end{aligned} \tag{4.4.8}$$

where $\bar{\epsilon}_{1,2} = 1 - \epsilon_{1,2}$. Using this identity, in Appendix C.3 we derive the formula

$$\begin{aligned}
 &\langle \text{Tr}(X^m Y^n) \text{Tr}(X^m Y^n)^\dagger \rangle \\
 &= \sum_{k_1, l_1=0}^m \sum_{k_2, l_2=0}^n \sum_{\substack{a_1, b_1=0 \\ a_2, b_2=0}}^{n+m} g \delta(k_1 + l_1 + 1 - m) \delta(k_2 + l_2 + 1 - n) F(a_1, b_1, a_2, b_2, k_1, l_1, k_2, l_2)
 \end{aligned} \tag{4.4.9}$$

where we defined the function

$$\begin{aligned}
 F(a_1, b_1, a_2, b_2, k_1, l_1, k_2, l_2) &= \frac{k_1! k_2! l_1! l_2! (a_1 - a_2)(b_1 - b_2)}{4(a_1 + b_2 + 1)(a_2 + b_1 + 1)(k_1 + l_1 + 1)(k_2 + l_2 + 1)} \\
 &\times \binom{a_1 + b_1}{b_1} \binom{a_2 + b_2}{b_2} \binom{N + a_1}{a_1 + b_1 + 1} \binom{N + a_2}{a_2 + b_2 + 1} \times \\
 &\times ((a_1 + b_1 + 1)(a_1 - b_1) + (a_2 + b_2 + 1)(a_2 - b_2) + \\
 &\quad - (k_1 + l_1 + 1)(k_1 - l_1) - (k_2 + l_2 + 1)(k_2 - l_2))^2
 \end{aligned} \tag{4.4.10}$$

In [86] a closed form for the two point function has been given by using a different approach based on Young-Yamanouchi symbols. We have checked agreement of (4.4.9) with that closed form for up to $n = m = 10$. It is an interesting exercise to simplify (4.4.9) into the closed form obtained in [86]. It will also be interesting to apply the present framework to obtain formulae analogous to (4.4.9) for more general GIOs corresponding to central elements of $\mathcal{A}(m, n)$.

In this section we have shown how to calculate a particular two point function of a central operator, without explicitly constructing projectors. The result rather follows from knowing how central operators of interest are generated via the star product of pure X gauge invariants, pure Y gauge invariants and descendants of half-BPS operators.

The correlator computations above can be expressed in terms of ribbon graphs, equivalently the usual double-line graphs of large N expansions, but with edges coming in two colors, as explained for example in [15]. The graphs can be organised by the minimum genus of the surface they can be embedded in and these graphs of a given genus contribute to a fixed power

of N . For small m, n , we have checked with GAP that directly computing the permutation sums for a given genus agree with the analytic result (4.4.9) we have derived.

4.5 Numerical checks, possible applications and other examples

4.5.1 Structure of the centre

A number of questions about $\mathcal{A}(n)$, $\mathcal{A}(m, n)$ and the centre $\mathcal{A}(m, n)$ can be explored experimentally, with the help of group theory software, notably GAP. In particular, since $\mathcal{Z}(m, n)$ is generated by the centre of S_m , the centre of S_n and that of S_{n+m} it is a useful first step to know about these centres.

Since S_n is generated by transpositions, one might naively expect that the sum of permutations T_2 will generate $\mathcal{A}(n)$. This is actually not true. We know that T_2 obeys a relation of degree $p(n)$

$$\prod_{R \vdash n} \left(T_2 - \frac{\chi_R(T_2)}{d_R} \right) = 0 \quad (4.5.1)$$

If this is the only relation, then we know that T_2 alone generates $\mathcal{Z}[\mathbb{C}[S_n]]$. However simpler relations occur when there are coincidences in the normalized characters, e.g. two different irreps have the same normalized character. In fact the failure of T_2 to generate centre is always correctly predicted by the degeneracies of the normalized characters. If we take

$$\prod'_R \left(T_2 - \frac{\chi_R(T_2)}{d_R} \right) = 0 \quad (4.5.2)$$

where the product is taken over a maximal set of irreps with distinct normalized characters, we are getting an element in $\mathbb{C}[S_n]$ which vanishes in all irreps. It is a central element, so the matrix elements in any irrep are proportional to the identity. We conclude that the above element vanishes. Given that the Peter-Weyl theorem gives an isomorphism between $\mathbb{C}[S_n]$ and matrix elements of irreps, it follows that something which has vanishing matrix elements in all irreps should be identically zero.

Even for large n , it is possible to check that the centre of $\mathbb{C}[S_n]$ is generated by a small number of T_p 's. Using GAP we tested that $T_{[2, 1^{n-2}]}$ and $T_{[3, 1^{n-3}]}$ are enough to generate the centre for $\mathbb{C}[S_n]$ up to $n = 14$. The procedure we used to perform these checks is the following. We know that the set of projectors $\{P_R\}$, with R integer partition of n , generate the centre of S_n . We can compute the overlap of P_R with the k -th power of T_p , that we simply write as T_p^k :

$$\begin{aligned} \langle T_p^k, P_R \rangle &= \delta(T_p^k, P_R) = \frac{1}{n!} \sum_{S \vdash n} \chi_S(T_p^k) \chi_S(P_R) = \frac{1}{n!} \sum_{S \vdash n} d_S \left(\frac{\chi_S(T_p)}{d_S} \right)^k \chi_S(P_R) \\ &= d_R \left(\frac{\chi_R(T_p)}{d_R} \right)^k \end{aligned} \quad (4.5.3)$$

Similarly, we can derive

$$\langle T_p^k T_q^l, P_R \rangle = d_R \left(\frac{\chi_R(T_p)}{d_R} \right)^k \left(\frac{\chi_R(T_q)}{d_R} \right)^l \quad (4.5.4)$$

Now we construct the $AB \times p(n)$ matrix $M(A, B)$, whose matrix elements are the overlaps (4.5.4):

$$M(A, B)|_{(k,l),R} = d_R \left(\frac{\chi_R(T_p)}{d_R} \right)^k \left(\frac{\chi_R(T_q)}{d_R} \right)^l \quad (4.5.5)$$

with $0 \leq k < A$ and $0 \leq l < B$. By computing the rank of this matrix we obtain the number of independent central elements in $\mathbb{C}[S_n]$ that are obtained by taking at most $A - 1$ powers of T_p and $B - 1$ powers of T_q . This method can be easily generalised to obtain the number of central elements generated by the string of operators $T_{p_1}^{k_1} T_{p_2}^{k_2} \dots T_{p_N}^{k_N}$.

These studies on the centre of $\mathbb{C}[S_n]$ inspire a similar analysis for centre of $\mathcal{A}(m, n)$. The task is to find a minimal set of generators for $\mathcal{Z}(m, n)$ as a polynomial algebra. The importance of this problem is discussed in section 4.3.3. Concretely, we would like to determine $N^{\min}(\mathcal{Z}(m, n))$. There are many approaches one can take in this case, which would be interesting to investigate in the future. For example, using GAP we checked that low powers of the sum of two- and three-cycles permutations, $T_2^{(m+n)}$ and $T_3^{(m+n)}$, together with the generators of the centres of $\mathbb{C}[S_m]$ and $\mathbb{C}[S_n]$, generate the whole centre $\mathcal{Z}(m, n)$. We leave a more systematic discussion of this problem for future work.

4.5.2 Construction of quarter-BPS operators beyond zero coupling and the structure constants of $\mathcal{A}(m, n)$.

The centre of $\mathbb{C}[S_{m+n}]$ is denoted by $\mathcal{Z}[\mathbb{C}[S_{m+n}]]$. $\mathcal{Z}[\mathbb{C}[S_{m+n}]]$ is a commutative sub-algebra of $\mathcal{A}(m, n)$. The $\mathcal{A}(m, n)$ algebra is a module over $\mathcal{Z}[\mathbb{C}[S_{m+n}]]$. We can write

$$\mathcal{T}_p N_i = \tilde{C}_{pj}^k N_k \quad (4.5.6)$$

for some coefficients \tilde{C} . The \mathcal{T}_p are themselves linear combinations of necklaces:

$$\mathcal{T}_p = T_p^i N_i \quad (4.5.7)$$

Hence

$$\mathcal{T}_p N_i = T_p^j N_j N_i = T_p^j C_{jk}^l N_l \quad (4.5.8)$$

Another subspace in $\mathcal{A}(m, n)$ is the subspace of symmetrised traces. A symmetrised trace S_v can be parametrised by a *vector partition* v of (m, n) . We can expand S_v on the basis of

necklaces $\{N_k\}$ as

$$S_v = S_v^k N_k \quad (4.5.9)$$

Symmetrised traces and their products are quarter-BPS at weak coupling in the large N limit. One can get the complete set of $1/N$ corrected BPS states at large N by acting on S_v with Ω^{-1} which belongs to $\mathcal{Z}[\mathbb{C}[S_{m+n}]] \otimes \mathbb{C}(1/N)$ [26, 28, 29, 90]. The coefficients of T_p are easily computable. The expansion of T_p in terms of necklaces is also easily computable. The non-trivial part of the calculation is the C_{ij}^k of the necklace algebra $\mathcal{A}(m, n)$. For any symmetrised trace S_v , the corrected operator is

$$\Omega_k^{-1} S_v = \Omega_p^{-1} T_p S_v^j N_j = \Omega_p^{-1} S_v^j \tilde{C}_{pj}^k N_k = \Omega_p^{-1} S_v^j T_p^l C_{lj}^k N_k \quad (4.5.10)$$

Central quarter BPS sector

A subspace of symmetrised trace elements is central. The symmetrised trace elements give a subspace of $\mathcal{A}(m, n)$ and the central elements form another subspace. The intersection is the space of central symmetrised traces. The dimension of this subspace can be computed for small m, n using GAP. Suppose S^C is an element in this subspace. Then elements $\Omega^{-1} S^C$ in $\mathcal{A}(m, n)$ are very interesting. They are quarter-BPS beyond zero coupling and they are central, so computations of their correlators have the simplicity of the centre. The computations can be done using knowledge of the characters of S_m, S_n, S_{m+n} , without knowing branching coefficients. From AdS/CFT this central quarter BPS sector should have a dual in the space-time theory, *e.g.* some sub-class of states in the tensor product of super-graviton states. An interesting question is to compute their correlators in space-time and verify the matching with the gauge theory computations.

4.5.3 Non-commutative geometry and topological field theory

Studies in non-commutative geometry in string theory suggest that open strings can be associated to non-commutative algebras and the centre is related to closed strings [94]. If we apply this thinking to $\mathcal{A}(m, n)$ and $\mathcal{Z}(m, n)$, how do we interpret these emergent open and closed strings? The traditional view is that Yang-Mills theory is the open-string picture in AdS/CFT with the closed string picture given by the AdS description, so this is an intriguing question. Non-commutative algebras and their centre have also been discussed in non-commutative geometry in [95]. The study of the pair $\{\mathcal{A}(m, n), \mathcal{Z}(m, n)\}$ should form an interesting example of this discussion. Additionally we have the Cartan $\mathcal{M}(m, n)$ here, with physical relevance in distinguishing the multiplicity labels. So a more complete picture of strings and non-commutative geometry for the triple $\{\mathcal{A}(m, n), \mathcal{M}(m, n), \mathcal{Z}(m, n)\}$ looks desirable. Given that the infinite direct sum $\mathcal{A}(\infty, \infty)$ comes up in connection with matrix invariants, it would also be interesting to study the triple $\{\mathcal{A}(\infty, \infty), \mathcal{M}(\infty, \infty), \mathcal{Z}(\infty, \infty)\}$ from this point of view. Some relevant work in this direction is in [41] (see also [96]).

4.5.4 Other examples of permutation centralizer algebras and correlators

Based on our study of $\mathcal{A}(m, n)$, we outline some properties of the other examples of permutation centralizer algebras given in section 4.1 and sketch the connection to correlators. We leave a more detailed development for the future.

Consider $\mathcal{B}_N(m, n)$, which is the subspace of the Brauer algebra $B_N(m, n)$ invariant under $\mathbb{C}[S_m \times S_n]$. This is Example 3 in Section 4.1. Brauer algebras were used to construct gauge invariant operators in [27] from tensor products of a complex matrix and its conjugate. For an element b in the walled Brauer algebra $B_N(m, n)$, we use

$$tr_{m,n} (Z^{\otimes m} \otimes \bar{Z}^{\otimes n} b) \quad (4.5.11)$$

where the trace is taken in $V^{\otimes m} \otimes \bar{V}^{\otimes n}$, a tensor product of fundamentals and anti-fundamentals of $U(N)$. We focus here on the case $m + n \leq N$. The number of gauge invariant operators is

$$\sum_{\gamma, \alpha, \beta} (M_{\alpha, \beta}^{\gamma})^2 \quad (4.5.12)$$

where γ labels an irrep of $B_N(m, n)$, while α, β are irreps of S_m and S_n respectively. $M_{\alpha, \beta}^{\gamma}$ is a multiplicity with which (α, β) appears in the reduction of γ from $B_N(m, n)$ to its $\mathbb{C}[S_m \times S_n]$ sub-algebra. The sum of squared dimensions in (4.5.12) is the dimension of the algebra $\mathcal{B}_N(m, n)$. This is a non-commutative algebra. The dimension of its centre is the number of triples (γ, α, β) for which $M_{\alpha, \beta}^{\gamma}$ is non-vanishing. There is a maximally commuting sub-algebra of dimension equal to the sum

$$\sum_{\gamma, \alpha, \beta} M_{\alpha, \beta}^{\gamma} \quad (4.5.13)$$

This follows since the (γ, α, β) give a Wedderburn-Artin decomposition of $\mathcal{B}_N(m, n)$. A tractable sector of correlators should be given by the centre of $\mathcal{B}_N(m, n)$ and more detailed study of the structure of this centre will be useful.

The next algebra of interest is the sub-algebra $\mathcal{K}(n)$ of $\mathbb{C}[S_n] \times \mathbb{C}[S_n]$ which is invariant under conjugation by $Diag(\mathbb{C}[S_n])$. Let us denote this as $\mathcal{A}_{diag}(n, n)$. We can generate elements in this algebra by summing over the elements of the sub-group

$$\sigma_1 \otimes \sigma_2 \rightarrow \sum_{\gamma \in S_n} \gamma \sigma_1 \gamma^{-1} \otimes \gamma \sigma_2 \gamma^{-1} \quad (4.5.14)$$

The dimension of this algebra is

$$\sum_{R, S, T} C(R, S, T)^2 \quad (4.5.15)$$

where $C(R, S, T)$ is the Kronecker coefficient, i.e. the number of times the irrep T of S_n appears in the tensor product $R \otimes S$. The dimension of the centre is the number of triples (R, S, T) for

which the $C(R, S, T)$ is non-zero. A maximal commuting sub-algebra has dimension

$$\sum_{R,S,T} C(R, S, T) \quad (4.5.16)$$

These properties follow from the fact the Wedderburn-Artin decomposition of the algebra $\mathcal{K}(n)$ has blocks labelled by triples (R, S, T) with non-vanishing $C(R, S, T)$. An explicit formula for this decomposition is

$$Q_{\tau_1, \tau_2}^{R,S,T} = \sum_{\sigma_1, \sigma_2} \sum_{i_1, i_2, i_3, j_1, j_2} S_{i_1, i_2, i_3}^{R,S,T, \tau_1} S_{j_1, j_2, i_3}^{R,S,T, \tau_2} D_{i_1 j_1}^R(\sigma_1) D_{i_2 j_2}^S(\sigma_2) \sigma_1 \otimes \sigma_2 \quad (4.5.17)$$

The D 's are representation matrices for S_n irreps. The S 's are Clebsch-Gordan coefficients. One verifies, using equivariance properties of the Clebsch's that these are invariant under conjugation by the diagonal S_n .

There is another definition of $\mathcal{K}(n)$ which is more symmetric in (R, S, T) . $C(R, S, T)$ is also the multiplicity of invariants of the diagonal S_n acting on $R \otimes S \otimes T$. $\mathcal{K}(n)$ can be defined as the subalgebra of $\mathbb{C}[S_n] \otimes \mathbb{C}[S_n] \otimes \mathbb{C}[S_n]$ which is invariant under left action by the diagonal $\mathbb{C}[S_n]$ and right action by the diagonal $\mathbb{C}[S_n]$. These invariant elements can again be constructed by averaging

$$\sum_{\gamma_1, \gamma_2} (\gamma_1 \sigma_1 \gamma_2, \gamma_1 \sigma_2 \gamma_2, \gamma_1 \sigma_3 \gamma_2) \quad (4.5.18)$$

A representation basis is given by

$$\sigma_1 \otimes \sigma_2 \otimes \sigma_3 D_{i_1, j_1}^R(\sigma_1) D_{i_2, j_2}^S(\sigma_2) D_{i_3, j_3}^T(\sigma_3) S_{i_1, i_2, i_3}^{R,S,T, \tau_1} S_{j_1, j_2, j_3}^{R,S,T, \tau_2} \quad (4.5.19)$$

labelled by R, S, T, τ_1, τ_2 .

These triples of permutations $(\sigma_1, \sigma_2, \sigma_3)$, with equivalences given by left and right diagonal action have appeared in the enumeration invariants for tensor models built from 3-index tensors [97]. The simplification from a description in terms of permutation triples to one in terms of permutation pairs was also described there, which lead to a connection between 3-index tensor invariants and Belyi maps. By analogy with the discussion in this thesis, we expect that the centre of $\mathcal{K}(n)$ will lead to a class of simpler correlators in tensor models. The discussion of $\mathcal{A}(\infty, \infty)$ will analogously lead to

$$\mathcal{K}(\infty) = \bigoplus_{n=0}^{\infty} \mathcal{K}(n) \quad (4.5.20)$$

This space will have two products: one related to the algebra structure of $\mathcal{K}(n)$ and one related to the multiplication of tensor invariants. Somewhat related algebraic structures appear in [98] and it would be useful to better understand these relations. As a last remark, consider the Kronecker multiplicities $C(R, R, T)$, *i.e.* in the special case where $R = S$. These have also appeared in the

construction of gauge-invariant multi-matrix operators in a basis which is covariant under the global symmetries [28, 29]. The structure of $\mathcal{K}(n)$ can thus also be expected to have implications for multi-matrix correlators in the covariant basis.

Chapter 5

Conclusions and Outlook

In this thesis we considered free quiver gauge theories with gauge group $\prod_{a=1}^n U(N_a)$ and flavour group $\prod_{a=1}^n U(F_a) \times U(\bar{F}_a)$.

In Chapter 2, based on [1], we focused on the problem of counting of local holomorphic operators in flavoured quiver gauge theories. We used Schur-Weyl duality relating the representation theory of unitary groups to permutation groups in order to convert integrals over the gauge unitary groups for the counting into permutation sums. The sums involved multiple permutations with constraints. These constraints were expressed by introducing contour integrals. This led to an analogous infinite product formula for these flavoured quivers (2.1.8). For any quiver with n gauge nodes, all the factors in the infinite product are obtained by substitutions in one function $F^{[n]}(\{x_{ab}\}, \{t_a\}, \{\bar{t}_a\})$, with a, b ranging over the n nodes. The building block $F^{[n]}(\{x_{ab}\}, \{t_a\}, \{\bar{t}_a\})$ was found to be closely related to $F_0^{[n]}(\{x_{ab}\})$. The determinant and cofactors of the matrix $(1_n - X_n)$ played a prominent role in these formulae. We also obtained results for the counting of local operators at finite N in terms of Young diagrams and Littlewood-Richardson coefficients.

The flavoured counting at large N is determined by $F^{[n]}$, which is closely related to $F_0^{[n]}$, which in turn we have related to word counting problems associated to the complete n -node quiver. One formulation of the word counting problem was in terms of words made from letters corresponding to simple closed loops on the quiver. The letters do not commute if they share a node, otherwise they commute. In another formulation, the letters correspond to edges of the quiver. Distinct letters do not commute if they share a starting point. These open string bits form words, a subset of which obey a charge conservation condition. A non-trivial combinatoric equivalence between the open string and closed string counting problems is given by the Cartier-Foata theorem. We have come across these string-word-counting problems in connection with the counting formula for gauge invariants. It is natural to ask if such words, and their monoidal structure, are relevant beyond the counting of gauge theory invariants. One often finds that mathematical structures relevant to counting a class of objects are also relevant in the understanding of the interactions of such objects (see e.g. [35, 74] for a concrete application of this idea). Do the string-words found here play a role in interactions, namely in the computation of correlators of gauge-invariant operators in the free field limit and at weak coupling? Since

the work of Cartier-Foata has subsequently been related to statistical physics models [72, 99], this underlying mathematical structure could reveal new connections between four dimensional gauge theory and statistical physics.

In the context of AdS/CFT, comparisons between the counting of a class of local gauge-invariant operators and the spectrum of brane fluctuations was initiated in [49–51]. These papers considered the simplest quiver gauge theory, namely $N = 4$ SYM, and the additional fundamental matter corresponds to the addition of 7-branes in the dual $AdS_5 \times S^5$ background. The results presented in Chapter 2 of this thesis should be useful for generalizations of these results, such as increasing the number of 7-branes, and more substantially, going beyond the $N = 4$ SYM as starting point to more general quiver theories. The finite N aspects of counting, where operators are labelled by Young diagrams, should be related to giant gravitons. This will require the investigation of 3-brane giant gravitons in $AdS_5 \times S^5$, in the presence of the probe 7-branes. Some discussion of such configurations is initiated in the conclusions of [100]. Such detailed comparisons for the general class of flavoured quiver theories we considered here would undoubtedly deepen our understanding of AdS/CFT.

In the absence of a superpotential, holomorphic GIOs form the space of chiral operators in the theory. When we turn on a superpotential, equivalence classes related by setting to zero the derivatives of the super-potential, form the chiral ring [101, 102]. This jump in the spectrum of chiral primaries has been discussed in the context of AdS/CFT in [103]. An important future direction is to understand this jump in quantitative detail. We have found that the quiver diagram defining a theory contains powerful information on the counting of operators in the theory, and the weighted adjacency matrix played a key role in giving a general form for the generating functions at large N . It would be interesting to look for analogous general formulae, involving the weighted adjacency matrix, along with the superpotential data, for the case of chiral rings at non-zero superpotential. In a similar vein we may ask if indices in superconformal theories, for general quivers, can be expressed in terms of the weighted adjacency matrix. It will be interesting to investigate this theme in existing examples of index computations for quivers (e.g. [104–106]). Beyond counting questions, the transition to non-zero superpotential poses the question of the exact form of BPS operators. In cases where the 1-loop dilatation operator is known, such as $\mathcal{N} = 4$ SYM, we can find the BPS operators by solving for the null eigenstates among the holomorphic operators. Partial results at large N as well as finite N , building on the knowledge of free field bases of operators, are available in [28, 29, 35, 55, 74, 90, 91, 107]. A similar treatment should be possible for orbifolds of $\mathcal{N} = 4$. The counting of chiral operators with and without superpotential is of interest in studying the Hilbert series of moduli spaces arising from super-symmetric gauge-theories [78, 108, 109]. These moduli spaces often have an interpretation in terms of branes. Quiver gauge theories, with and without fundamental matter, have been studied in this context. The formulae obtained here, for finite N as well as large N , will be expected to have applications in the study of these moduli spaces. Another potential application of the present counting techniques is in the thermodynamics of AdS/CFT or toy models thereof, e.g. [110].

For quiver gauge theories with bi-fundamental matter (no fundamental matter), the counting and correlators of gauge invariant operators can be expressed in terms of defect observables in two dimensional topological field theories (TFT2). These theories are based on lattice gauge theory where permutation groups play the role of gauge groups [26]. The relevant two dimensional surfaces were obtained by a process of thickening the quiver. This leads us to expect that the counting and correlators for the present case can be expressed in terms of defect observables in TFT2 on Riemann surfaces with boundary. It will be very interesting to elaborate on this in the future. Another interesting future direction is the relation of gauge invariant correlators to the counting of branched covers. This has been discussed for the case of a single gauge group and one or more adjoint fields [90, 111–115]. The equation (3.3.12) giving the formula for the 2-point function in the permutation basis would be a good starting point. By tracing the flavour indices, we expect to see that powers of the flavour rank are related to the counting of covering surfaces with boundaries (see for example [116]).

In Chapter 3, based on [3], we found that the basis of Quiver Restricted Schur polynomials (3.2.19) diagonalises the two point function (3.3.1). Relying on diagrammatic methods, we also provided an analytical finite N expression for the three point function of holomorphic matrix invariants. The relevant diagram is shown in Fig. 34. An interesting future direction is the relation of gauge invariant correlators to the counting of branched covers. This has been discussed for the case of a single gauge group and one or more adjoint fields [90, 111–115]. The equation (3.3.12) giving the formula for the 2-point function in the permutation basis would be a good starting point. By tracing the flavour indices, we expect to see that powers of the flavour rank are related to the counting of covering surfaces with boundaries (see for example [116]).

Another interesting line of research would be to study the action of the one-loop dilatation operator on the basis of matrix invariants (3.2.19) for flavoured theories, possibly in some simple subsector. The action of the one-loop dilatation operator on the Schur basis for $\mathcal{N} = 4$ SYM has already been studied [35, 117]. For example, in the giant graviton sector of $\mathcal{N} = 4$ SYM, the explicit action of the one-loop dilatation operator corresponds to moving a single box in the Young diagram that parametrises the giant graviton. It is an open problem to find analogous results in flavoured theories: an interesting starting point would be $\mathcal{N} = 2$ SQCD with gauge group $SU(N)$ and flavour symmetry $SU(2N)$, which is a conformal theory. An explicit basis for its matrix invariants is given in (3.5.2).

Chapter 4 is based on the results of [2]. We initiated a systematic study of Permutation Centralizer Algebras (PCAs), in connection with gauge invariant operators. We focused our attention on the algebras $\mathcal{A}(m, n)$ which are related to restricted Schur operators studied in the context of giant gravitons in AdS/CFT. Other closely related algebras are related to the Brauer basis for multi-matrix invariants, the covariant basis and to tensor models.

While many of the key formulae we have used were already understood in the literature on giant gravitons, we have emphasized the intrinsic structure of $\mathcal{A}(m, n)$ as an associative algebra with a non-degenerate pairing. This means that it has a Wedderburn-Artin decomposition, which gives a basis for the algebra in terms of matrix-like linear combinations. The construction

of these matrix-units in terms of representation theory data from S_{m+n}, S_m, S_n has already been extensively used in the context of giant gravitons, although the link to the Wedderburn-Artin decomposition has not been made explicit before. In addition to explicating this link, the new emphasis in 4 has been on the structure of the centre $\mathcal{Z}(m, n)$ and the maximally commuting sub-algebra $\mathcal{M}(m, n)$.

We have used the structure of $\mathcal{M}(m, n)$ as a polynomial algebra over $\mathcal{Z}(m, n)$ to characterize the minimal number of charges needed to identify any 2-matrix gauge invariant (section 4.3.3). It will be interesting to generalize this discussion to gauge invariants for more general gauge groups.

Two key structural facts about $\mathcal{A}(m, n)$ have played a role in the computation of correlators in Section 4.4. The first is that $(x^m) * (y^n) = (x^m y^n)$ and the second is that $(x^m y^n)$ is part of $\mathcal{Z}(m, n)$. The non-degenerate pairing on $\mathcal{A}(m, n)$, when restricted to elements in the centre, can be expressed in terms of characters of S_n, S_m, S_{n+m} without requiring more detailed representation theory data such as matrix elements and branching coefficients. These are in general computationally hard to calculate, although there has been progress in the context of “perturbations of half-BPS giants”. This makes it very interesting to understand the structure of the centre $\mathcal{A}(m, n)$. A special case is $\mathcal{Z}[\mathbb{C}[S_n]]$, which is the algebra of class sums in S_n .

For the case of a single gauge group but multi-matrices (quiver with one node and multiple edges), a complete set of charges measuring the group theoretic labels of orthogonal bases for gauge invariant operators were given in [54]. They were constructed from Noether charges for enhanced symmetries in the zero coupling limit. We have shown that a minimal set of charges can be characterised by using properties of PCAs. We expect similar applications of PCAs to gauge invariant operators in general quiver theories (without fundamental matter) to proceed in a fairly similar manner. For the case of quivers with fundamental matter, we may expect that appropriate PCAs along with modules over these algebras will play a role. There are in fact two ways one might associate a PCA to quiver with fundamentals. One is to excise the flavour legs of the quiver to be left with a quiver with bi-fundamentals only. Putting back the legs might correspond to going from algebra to a broader construction involving modules over the algebra. The other way is to tie all the incoming and outgoing legs to a single new node, preserving their orientation. This latter procedure was useful in consideration of the counting of gauge invariant operators [1].

The broad summary of this thesis is that the quiver, combined with its corresponding permutation algebras and topological field theories, can be a powerful device in constructing correlators of gauge invariant observables and in exposing their hidden geometrical structures.

Appendix A

Quiver Characters and Correlators: Proofs

A.1 Operator invariance

In this appendix we will derive the identity (3.1.15). Let us consider a matrix Φ in the bi-fundamental $(\square, \bar{\square})$ representation of $U(N_a) \times U(N_b)$, and a permutation $\eta \in S_n$. Eq. (3.1.15) arises from the equivalence

$$\eta^{-1} (\Phi^{\otimes n}) \eta = \Phi^{\otimes n} \quad \Rightarrow \quad [\Phi^{\otimes n}, \eta] = 0 \quad (\text{A.1.1})$$

which follows from the identities

$$\begin{aligned} \langle e^{i_1}, e^{i_2}, \dots, e^{i_n} | \Phi^{\otimes n} | e_{j_1}, e_{j_2}, \dots, e_{j_n} \rangle &= (\Phi^{\otimes n})_{j_1, j_2, \dots, j_n}^{i_1, i_2, \dots, i_n} = \Phi_{j_1}^{i_1} \Phi_{j_2}^{i_2} \dots \Phi_{j_n}^{i_n} = \Phi_{j_{\eta(1)}}^{i_{\eta(1)}} \Phi_{j_{\eta(2)}}^{i_{\eta(2)}} \dots \Phi_{j_{\eta(n)}}^{i_{\eta(n)}} \\ &= (\Phi^{\otimes n})_{j_{\eta(1)}, j_{\eta(2)}, \dots, j_{\eta(n)}}^{i_{\eta(1)}, i_{\eta(2)}, \dots, i_{\eta(n)}} = \langle e^{i_{\eta(1)}}, e^{i_{\eta(2)}}, \dots, e^{i_{\eta(n)}} | \Phi^{\otimes n} | e_{j_{\eta(1)}}, e_{j_{\eta(2)}}, \dots, e_{j_{\eta(n)}} \rangle \\ &= \langle e^{i_1}, e^{i_2}, \dots, e^{i_n} | \eta^{-1} \Phi^{\otimes n} \eta | e_{j_1}, e_{j_2}, \dots, e_{j_n} \rangle, \quad \eta \in S_n \end{aligned} \quad (\text{A.1.2})$$

Here $|e_{j_1}, e_{j_2}, \dots, e_{j_n}\rangle \in V_{N_a}^{\otimes n}$ and $\langle e^{j_1}, e^{j_2}, \dots, e^{j_n} | \in \bar{V}_{N_b}^{\otimes n}$, V_{N_a} and \bar{V}_{N_b} being the fundamental and antifundamental representations of $U(N_a)$ and $U(N_b)$ respectively. In the following, we will need the two identities

$$\begin{aligned} (Q^{\otimes n} \rho)_{\mathbf{s}}^I &= \langle e^{i_1}, e^{i_2}, \dots, e^{i_n} | Q^{\otimes n} \rho | e_{s_1}, e_{s_2}, \dots, e_{s_n} \rangle \\ &= \langle e^{i_1}, e^{i_2}, \dots, e^{i_n} | Q^{\otimes n} | e_{s_{\rho(1)}}, e_{s_{\rho(2)}}, \dots, e_{s_{\rho(n)}} \rangle = (Q^{\otimes n})_{\rho(\mathbf{s})}^I \end{aligned} \quad (\text{A.1.3})$$

and

$$\begin{aligned} (\bar{\rho}^{-1} \bar{Q}^{\otimes n})_{\bar{J}}^{\bar{\mathbf{s}}} &= \langle e^{\bar{s}_1}, e^{\bar{s}_2}, \dots, e^{\bar{s}_n} | \bar{\rho}^{-1} \bar{Q}^{\otimes n} | e_{j_1}, e_{j_2}, \dots, e_{j_n} \rangle \\ &= \langle e^{\bar{s}_{\bar{\rho}(1)}}, e^{\bar{s}_{\bar{\rho}(2)}}, \dots, e^{\bar{s}_{\bar{\rho}(n)}} | \bar{Q}^{\otimes n} | e_{j_1}, e_{j_2}, \dots, e_{j_n} \rangle = (\bar{Q}^{\otimes n})_{\bar{J}}^{\bar{\rho}(\bar{\mathbf{s}})} \end{aligned} \quad (\text{A.1.4})$$

Now let us consider a generic GIO $\mathcal{O}_{\mathcal{Q}}(\vec{n}; \vec{s}; \vec{\sigma})$, built with $n_{ab,\alpha}$ type $\Phi_{ab,\alpha}$ fields, $n_{a,\beta}$ type $Q_{a,\beta}$ fields and $\bar{n}_{a,\gamma}$ type $\bar{Q}_{a,\gamma}$ fields. We also introduce the permutations

$$\vec{\eta} = \cup_{a,b,\alpha} \{\eta_{ab,\alpha}\}, \quad \eta_{ab,\alpha} \in S_{n_{ab,\alpha}} \quad (\text{A.1.5a})$$

$$\vec{\rho} = \cup_a \{\cup_{\beta} \rho_{a,\beta}; \cup_{\gamma} \bar{\rho}_{a,\gamma}\}, \quad \rho_{a,\beta} \in S_{n_{a,\beta}}, \quad \bar{\rho}_{a,\gamma} \in S_{\bar{n}_{a,\gamma}} \quad (\text{A.1.5b})$$

From (A.1.1), we then have the equivalences

$$\eta_{ab,\alpha}^{-1} \left(\Phi_{ab,\alpha}^{\otimes n_{ab,\alpha}} \right) \eta_{ab,\alpha} = \Phi_{ab,\alpha}^{\otimes n_{ab,\alpha}}, \quad \rho_{a,\beta}^{-1} \left(Q_{a,\beta}^{\otimes n_{a,\beta}} \right) \rho_{a,\beta} = Q_{a,\beta}^{\otimes n_{a,\beta}}, \quad \bar{\rho}_{a,\gamma}^{-1} \left(\bar{Q}_{a,\gamma}^{\otimes \bar{n}_{a,\gamma}} \right) \bar{\rho}_{a,\gamma} = \bar{Q}_{a,\gamma}^{\otimes \bar{n}_{a,\gamma}} \quad (\text{A.1.6})$$

for every $a, b, \alpha, \beta, \gamma$. Inserting these identities in (3.1.12) gives

$$\begin{aligned} \mathcal{O}_{\mathcal{Q}}(\vec{n}; \vec{s}; \vec{\sigma}) &= \prod_a \left[\prod_{b,\alpha} \left(\eta_{ab,\alpha}^{-1} \left(\Phi_{ab,\alpha}^{\otimes n_{ab,\alpha}} \right) \eta_{ab,\alpha} \right)_{J_{ab,\alpha}}^{I_{ab,\alpha}} \right] \otimes \left[\prod_{\beta} \left(\rho_{a,\beta}^{-1} \left(Q_{a,\beta}^{\otimes n_{a,\beta}} \right) \rho_{a,\beta} \right)_{\mathbf{s}_{a,\beta}}^{I_{a,\beta}} \right] \\ &\quad \otimes \left[\prod_{\gamma} \left(\bar{\rho}_{a,\gamma}^{-1} \left(\bar{Q}_{a,\gamma}^{\otimes \bar{n}_{a,\gamma}} \right) \bar{\rho}_{a,\gamma} \right)_{\bar{J}_{a,\gamma}}^{\bar{\mathbf{s}}_{a,\gamma}} \right] (\sigma_a)_{\times_{b,\alpha} J_{ba,\alpha} \times_{\gamma} \bar{J}_{a,\gamma}}^{\times_{b,\alpha} I_{ab,\alpha} \times_{\beta} I_{a,\beta}} \\ &= \prod_a \left[\prod_{b,\alpha} \left(\Phi_{ab,\alpha}^{\otimes n_{ab,\alpha}} \right)_{L_{ab,\alpha}}^{K_{ab,\alpha}} \right] \otimes \left[\prod_{\beta} \left(Q_{a,\beta}^{\otimes n_{a,\beta}} \rho_{a,\beta} \right)_{\mathbf{s}_{a,\beta}}^{K_{a,\beta}} \right] \otimes \left[\prod_{\gamma} \left(\bar{\rho}_{a,\gamma}^{-1} \bar{Q}_{a,\gamma}^{\otimes \bar{n}_{a,\gamma}} \right)_{\bar{L}_{a,\gamma}}^{\bar{\mathbf{s}}_{a,\gamma}} \right] \\ &\quad \times \left[\prod_{b,\alpha} \left(\eta_{ab,\alpha} \right)_{J_{ab,\alpha}}^{I_{ab,\alpha}} \right] \left[\prod_{\gamma} \left(\bar{\rho}_{a,\gamma} \right)_{\bar{J}_{a,\gamma}}^{\bar{L}_{a,\gamma}} \right] (\sigma_a)_{\times_{b,\alpha} J_{ba,\alpha} \times_{\gamma} \bar{J}_{a,\gamma}}^{\times_{b,\alpha} I_{ab,\alpha} \times_{\beta} I_{a,\beta}} \left[\prod_{b,\alpha} \left(\eta_{ab,\alpha}^{-1} \right)_{K_{ab,\alpha}}^{I_{ab,\alpha}} \right] \left[\prod_{\beta} \left(\rho_{a,\beta}^{-1} \right)_{K_{a,\beta}}^{I_{a,\beta}} \right] \end{aligned} \quad (\text{A.1.7})$$

Now we use the equations (A.1.3) and (A.1.4) to obtain

$$\begin{aligned} \mathcal{O}_{\mathcal{Q}}(\vec{n}; \vec{s}; \vec{\sigma}) &= \prod_a \left[\prod_{b,\alpha} \left(\Phi_{ab,\alpha}^{\otimes n_{ab,\alpha}} \right)_{L_{ab,\alpha}}^{K_{ab,\alpha}} \right] \otimes \left[\prod_{\beta} \left(Q_{a,\beta}^{\otimes n_{a,\beta}} \right)_{\rho_{a,\beta}(\mathbf{s}_{a,\beta})}^{K_{a,\beta}} \right] \otimes \left[\prod_{\gamma} \left(\bar{Q}_{a,\gamma}^{\otimes \bar{n}_{a,\gamma}} \right)_{\bar{L}_{a,\gamma}}^{\bar{\rho}_{a,\gamma}(\bar{\mathbf{s}}_{a,\gamma})} \right] \\ &\quad \times \left(\left(\times_{b,\alpha} \eta_{ba,\alpha} \times_{\gamma} \bar{\rho}_{a,\gamma} \right) \sigma_a \left(\times_{b,\alpha} \eta_{ab,\alpha}^{-1} \times_{\beta} \rho_{a,\beta}^{-1} \right) \right)_{\times_{b,\alpha} K_{ab,\alpha} \times_{\beta} K_{a,\beta}}^{\times_{b,\alpha} L_{ba,\alpha} \times_{\gamma} \bar{L}_{a,\gamma}} \\ &= \mathcal{O}_{\mathcal{Q}}(\vec{n}; \vec{\rho}(\vec{s}); \text{Adj}_{\vec{\eta} \times \vec{\rho}}(\vec{\sigma})) \end{aligned} \quad (\text{A.1.8})$$

where we also used the definition of $\text{Adj}_{\bar{\eta} \times \bar{\rho}}(\vec{\sigma})$, eq. (3.1.17):

$$\text{Adj}_{\bar{\eta} \times \bar{\rho}}(\vec{\sigma}) = \cup_a \{ (\times_{b,\alpha} \eta_{ba,\alpha} \times_{\gamma} \bar{\rho}_{a,\gamma}) \sigma_a (\times_{b,\alpha} \eta_{ab,\alpha}^{-1} \times_{\beta} \rho_{a,\beta}^{-1}) \} \quad (\text{A.1.9})$$

We thus have explicitly shown the equivalence (3.1.15).

As it usually is the case when working in this framework, (3.1.15) has a pictorial interpretation. We now give an example of this diagrammatic interpretation, for the simple case of an $\mathcal{N} = 2$ SQCD. The $\mathcal{N} = 1$ quiver for this model is the one depicted in Fig. 20. Let us then consider an $\mathcal{N} = 2$ SQCD GIO built with n adjoint fields ϕ and n_q quarks Q and antiquarks \bar{Q} . Each quark comes with a fixed state s_i state belonging to the fundamental representation of the flavour group $SU(F)$. We label the collection of these n_q states as $\mathbf{s} = (s_1, s_2, \dots, s_{n_q})$. Similarly, $\bar{\mathbf{s}} = (\bar{s}_1, \bar{s}_2, \dots, \bar{s}_{n_q})$ is the collection of the $SU(F)$ antifundamental states of the antiquarks \bar{Q} . The generic GIO $\mathcal{O}_{\mathcal{Q}}(n, n_q; \mathbf{s}, \bar{\mathbf{s}}; \sigma)$ can be drawn as in Fig. 42.

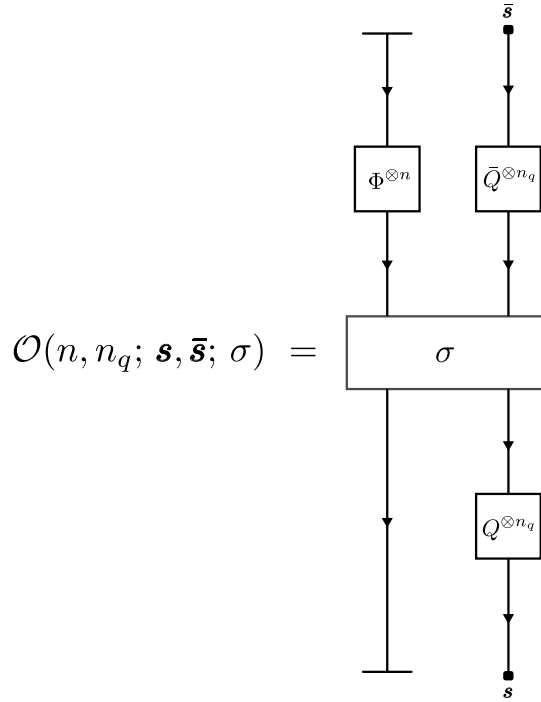

Figure 42: Diagram corresponding to a generic $\mathcal{N} = 2$ SQCD GIO.

The horizontal bars denotes the identification of the indices. Specialising eq. (3.1.15) to this case, we have the identity

$$\mathcal{O}(n, n_q; \mathbf{s}, \bar{\mathbf{s}}; \sigma) = \mathcal{O}(n, n_q; \rho(\mathbf{s}), \bar{\rho}(\bar{\mathbf{s}}); \text{Adj}_{\eta \times \rho}(\sigma)) \quad (\text{A.1.10})$$

for $\sigma \in S_{n+n_q}$, $\eta \in S_n$ and $\rho, \bar{\rho} \in S_{n_q}$. This equivalence is described in diagrammatic terms in Fig. 43.

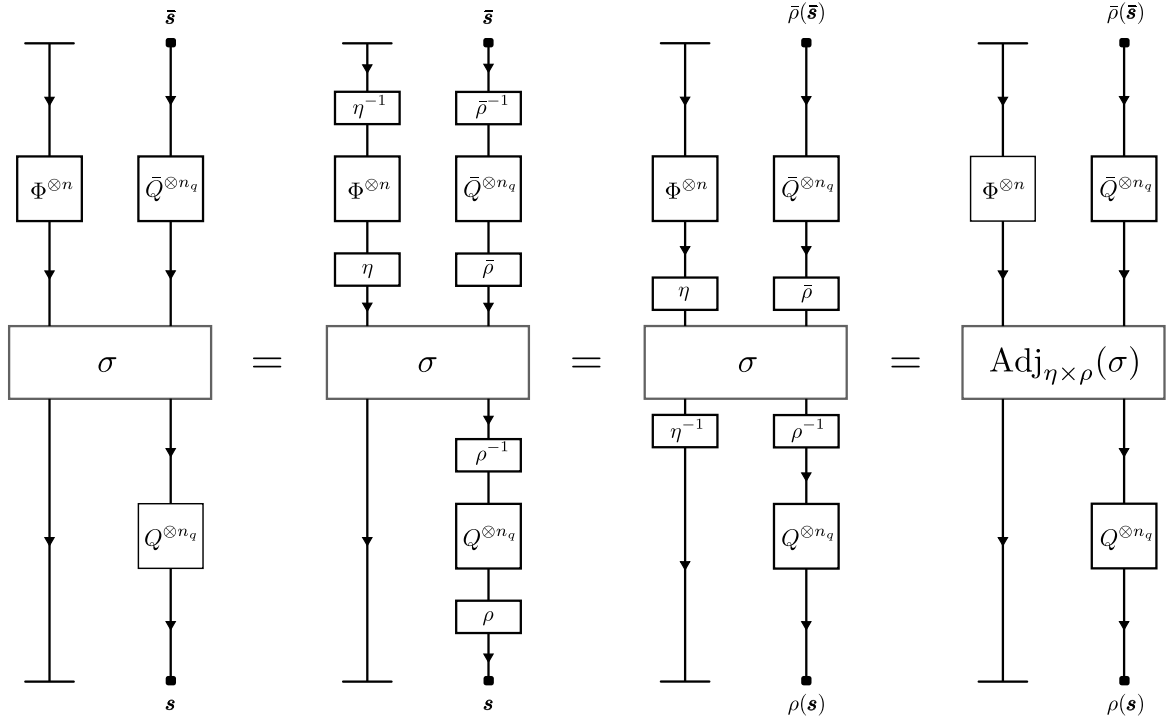

Figure 43: Diagrammatic interpretation of the identity (A.1.10).

A.2 Quiver character identities

In this appendix we will derive equations (3.2.23), (3.2.25) and (3.2.26). Many of the symmetric group identities that we will use in this appendix were already introduced and discussed in Appendix A of [26].

A.2.1 Invariance Relation

In this section we will prove formula (3.2.23):

$$\chi_{\mathcal{Q}}(\mathbf{L}, \vec{s}, \vec{\sigma}) = \chi_{\mathcal{Q}}(\mathbf{L}, \vec{\rho}(\vec{s}), \text{Adj}_{\vec{\rho} \times \vec{\eta}}(\vec{\sigma})) \quad (\text{A.2.1})$$

Using the definition of $\text{Adj}_{\vec{\rho} \times \vec{\eta}}(\vec{\sigma})$ given in (3.1.17)

$$\text{Adj}_{\vec{\rho} \times \vec{\eta}}(\vec{\sigma}) = \cup_a \{ (\times_{b,\alpha} \eta_{ba,\alpha} \times_{\gamma} \bar{\rho}_{a,\gamma}) \sigma_a (\times_{b,\alpha} \eta_{ab,\alpha}^{-1} \times_{\beta} \rho_{a,\beta}^{-1}) \} \quad (\text{A.2.2})$$

we start by writing

$$\begin{aligned}
 \chi_{\mathcal{Q}}(\mathbf{L}, \vec{s}, \text{Adj}_{\vec{\rho} \times \vec{\eta}}(\vec{\sigma})) &= c_{\mathbf{L}} \prod_a \sum_{i_a, j_a} \sum_{\substack{l_{ab, \alpha} \\ l_{a, \beta}, \bar{l}_{a, \gamma}}} D_{i_a, j_a}^{R_a} ((\times_{b, \alpha} \eta_{ba, \alpha} \times_{\gamma} \bar{\rho}_{a, \gamma}) \sigma_a (\times_{b, \alpha} \eta_{ab, \alpha}^{-1} \times_{\beta} \rho_{a, \beta}^{-1})) \\
 &\quad \times B_{j_a \rightarrow \cup_{b, \alpha} l_{ab, \alpha} \cup_{\beta} l_{a, \beta}}^{R_a \rightarrow \cup_{b, \alpha} r_{ab, \alpha} \cup_{\beta} r_{a, \beta}; \nu_a^-} \left(\prod_{\beta} C_{\mathbf{s}_{a, \beta}}^{r_{a, \beta}, S_{a, \beta}, l_{a, \beta}} \right) B_{i_a \rightarrow \cup_{b, \alpha} l_{ba, \alpha} \cup_{\gamma} \bar{l}_{a, \gamma}}^{R_a \rightarrow \cup_{b, \alpha} r_{ba, \alpha} \cup_{\gamma} \bar{r}_{a, \gamma}; \nu_a^+} \left(\prod_{\gamma} C_{\bar{r}_{a, \gamma}, \bar{S}_{a, \gamma}, \bar{l}_{a, \gamma}}^{\bar{s}_{a, \gamma}} \right) \\
 &= c_{\mathbf{L}} \prod_a \sum_{i_a, j_a} \sum_{\substack{l_{ab, \alpha} \\ l_{a, \beta}, \bar{l}_{a, \gamma}}} D_{i_a, i'_a}^{R_a} (\times_{b, \alpha} \eta_{ba, \alpha} \times_{\gamma} \bar{\rho}_{a, \gamma}) D_{i'_a, j'_a}^{R_a} (\sigma_a) D_{j'_a, j_a}^{R_a} (\times_{b, \alpha} \eta_{ab, \alpha}^{-1} \times_{\beta} \rho_{a, \beta}^{-1}) \\
 &\quad \times B_{j_a \rightarrow \cup_{b, \alpha} l_{ab, \alpha} \cup_{\beta} l_{a, \beta}}^{R_a \rightarrow \cup_{b, \alpha} r_{ab, \alpha} \cup_{\beta} r_{a, \beta}; \nu_a^-} \left(\prod_{\beta} C_{\mathbf{s}_{a, \beta}}^{r_{a, \beta}, S_{a, \beta}, l_{a, \beta}} \right) B_{i_a \rightarrow \cup_{b, \alpha} l_{ba, \alpha} \cup_{\gamma} \bar{l}_{a, \gamma}}^{R_a \rightarrow \cup_{b, \alpha} r_{ba, \alpha} \cup_{\gamma} \bar{r}_{a, \gamma}; \nu_a^+} \left(\prod_{\gamma} C_{\bar{r}_{a, \gamma}, \bar{S}_{a, \gamma}, \bar{l}_{a, \gamma}}^{\bar{s}_{a, \gamma}} \right)
 \end{aligned} \tag{A.2.3}$$

To ease the notation, for the remainder of this section we will drop the summation symbol in our equations. The sum over repeated symmetric group state indices will therefore be implicit. Notice however that there is no summation over the repeated representation labels $r_{ab, \alpha}$, $r_{a, \beta}$, $\bar{r}_{a, \gamma}$. Using the equivariance property of the branching coefficients [83]

$$D_{k, j}^R (\times_a \gamma_a) B_{j \rightarrow \cup_a l_a}^{R \rightarrow \cup_a r_a; \nu_a} = \left(\prod_a D_{l'_a, l_a}^{r_a} (\gamma_a) \right) B_{k \rightarrow \cup_a l'_a}^{R \rightarrow \cup_a r_a; \nu_a} \tag{A.2.4}$$

we can write

$$\begin{aligned}
 D_{j'_a, j_a}^{R_a} (\times_{b, \alpha} \eta_{ab, \alpha}^{-1} \times_{\beta} \rho_{a, \beta}^{-1}) B_{j_a \rightarrow \cup_{b, \alpha} l_{ab, \alpha} \cup_{\beta} l_{a, \beta}}^{R_a \rightarrow \cup_{b, \alpha} r_{ab, \alpha} \cup_{\beta} r_{a, \beta}; \nu_a^-} \\
 = \left(\prod_{b, \alpha} D_{l'_{ab, \alpha}, l_{ab, \alpha}}^{r_{ab, \alpha}} (\eta_{ab, \alpha}^{-1}) \prod_{\beta} D_{l'_{a, \beta}, l_{a, \beta}}^{r_{a, \beta}} (\rho_{a, \beta}^{-1}) \right) B_{j'_a \rightarrow \cup_{b, \alpha} l'_{ab, \alpha} \cup_{\beta} l'_{a, \beta}}^{R_a \rightarrow \cup_{b, \alpha} r_{ab, \alpha} \cup_{\beta} r_{a, \beta}; \nu_a^-}
 \end{aligned} \tag{A.2.5}$$

and

$$\begin{aligned}
 D_{i'_a, i_a}^{R_a} (\times_{b, \alpha} \eta_{ba, \alpha} \times_{\gamma} \bar{\rho}_{a, \gamma}) B_{i_a \rightarrow \cup_{b, \alpha} l_{ba, \alpha} \cup_{\gamma} \bar{l}_{a, \gamma}}^{R_a \rightarrow \cup_{b, \alpha} r_{ba, \alpha} \cup_{\gamma} \bar{r}_{a, \gamma}; \nu_a^+} \\
 = \left(\prod_{b, \alpha} D_{l_{ba, \alpha}, l_{ba, \alpha}''}^{r_{ba, \alpha}} (\eta_{ba, \alpha}) \prod_{\gamma} D_{\bar{l}_{a, \gamma}, \bar{l}_{a, \gamma}''}^{\bar{r}_{a, \gamma}} (\bar{\rho}_{a, \gamma}) \right) B_{i'_a \rightarrow \cup_{b, \alpha} l_{ba, \alpha}'' \cup_{\gamma} \bar{l}_{a, \gamma}''}^{R_a \rightarrow \cup_{b, \alpha} r_{ba, \alpha} \cup_{\gamma} \bar{r}_{a, \gamma}; \nu_a^+}
 \end{aligned} \tag{A.2.6}$$

Inserting the last two equations in (A.2.3) gives

$$\begin{aligned}
 \chi_{\mathcal{Q}}(\mathbf{L}, \vec{s}, \text{Adj}_{\vec{\rho} \times \vec{\eta}}(\vec{\sigma})) &= c_{\mathbf{L}} \prod_a D_{i'_a, j'_a}^{R_a}(\sigma_a) \left\{ \prod_{b, \alpha} D_{l'_{ab, \alpha}, l_{ab, \alpha}}^{r_{ab, \alpha}}(\eta_{ab, \alpha}^{-1}) D_{l_{ba, \alpha}, l_{ba, \alpha}''}^{r_{ba, \alpha}}(\eta_{ba, \alpha}) \right\} \\
 &\times B_{j'_a \rightarrow \cup_{b, \alpha} l'_{ab, \alpha} \cup_{\beta} l'_{a, \beta}}^{R_a \rightarrow \cup_{b, \alpha} r_{ab, \alpha} \cup_{\beta} r_{a, \beta}, \nu_a^-} \left\{ \prod_{\beta} D_{l_{a, \beta}, l'_{a, \beta}}^{r_{a, \beta}}(\rho_{a, \beta}) C_{\mathbf{s}_{a, \beta}}^{r_{a, \beta}, S_{a, \beta}, l_{a, \beta}} \right\} \\
 &\times B_{i'_a \rightarrow \cup_{b, \alpha} l_{ba, \alpha}'' \cup_{\gamma} l_{a, \gamma}''}^{R_a \rightarrow \cup_{b, \alpha} r_{ba, \alpha} \cup_{\gamma} \bar{r}_{a, \gamma}; \nu_a^+} \left\{ \prod_{\gamma} D_{\bar{l}_{a, \gamma}, \bar{l}_{a, \gamma}''}^{\bar{r}_{a, \gamma}}(\bar{\rho}_{a, \gamma}) C_{\bar{r}_{a, \gamma}, \bar{S}_{a, \gamma}, \bar{l}_{a, \gamma}}^{\bar{\mathbf{s}}_{a, \gamma}} \right\} \quad (\text{A.2.7})
 \end{aligned}$$

A first simplification comes from noticing that

$$\prod_{a, b, \alpha} D_{l'_{ab, \alpha}, l_{ab, \alpha}}^{r_{ab, \alpha}}(\eta_{ab, \alpha}^{-1}) D_{l_{ba, \alpha}, l_{ba, \alpha}''}^{r_{ba, \alpha}}(\eta_{ba, \alpha}) = \prod_{a, b, \alpha} \delta_{l'_{ab, \alpha}, l_{ab, \alpha}''} \quad (\text{A.2.8})$$

We now focus on the Clebsch-Gordan coefficients. Let us first consider the chain of equalities

$$\begin{aligned}
 D_{i, i'}^R(\sigma) C_{\mathbf{s}}^{R, M, i} &= D_{i, i'}^R(\sigma) \langle \mathbf{s} | R, M, i \rangle = \langle \mathbf{s} | D(\sigma) | R, M, i' \rangle \\
 &= \langle D(\sigma)^{-1} \mathbf{s} | R, M, i' \rangle = \langle \sigma^{-1}(\mathbf{s}) | R, M, i' \rangle = C_{\sigma^{-1}(\mathbf{s})}^{R, M, i'} \quad (\text{A.2.9})
 \end{aligned}$$

We can use this identity to write

$$D_{l_{a, \beta}, l'_{a, \beta}}^{r_{a, \beta}}(\rho_{a, \beta}) C_{\mathbf{s}_{a, \beta}}^{r_{a, \beta}, S_{a, \beta}, l_{a, \beta}} = C_{\rho_{a, \beta}^{-1}(\mathbf{s}_{a, \beta})}^{r_{a, \beta}, S_{a, \beta}, l'_{a, \beta}} \quad (\text{A.2.10})$$

and

$$D_{\bar{l}_{a, \gamma}, \bar{l}_{a, \gamma}''}^{\bar{r}_{a, \gamma}}(\bar{\rho}_{a, \gamma}) C_{\bar{r}_{a, \gamma}, \bar{S}_{a, \gamma}, \bar{l}_{a, \gamma}}^{\bar{\mathbf{s}}_{a, \gamma}} = C_{\bar{\rho}_{a, \gamma}^{-1}(\bar{\mathbf{s}}_{a, \gamma})}^{\bar{r}_{a, \gamma}, \bar{S}_{a, \gamma}, \bar{l}_{a, \gamma}''} \quad (\text{A.2.11})$$

Using these results in (A.2.7) we then get

$$\begin{aligned}
 \chi_{\mathcal{Q}}(\mathbf{L}, \vec{s}, \text{Adj}_{\vec{\rho} \times \vec{\eta}}(\vec{\sigma})) &= c_{\mathbf{L}} \prod_a D_{i'_a, j'_a}^{R_a}(\sigma_a) \left(\prod_{b, \alpha} \delta_{l'_{ab, \alpha}, l_{ab, \alpha}''} \right) \\
 &\times B_{j'_a \rightarrow \cup_{b, \alpha} l'_{ab, \alpha} \cup_{\beta} l'_{a, \beta}}^{R_a \rightarrow \cup_{b, \alpha} r_{ab, \alpha} \cup_{\beta} r_{a, \beta}, \nu_a^-} \left\{ \prod_{\beta} C_{\rho_{a, \beta}^{-1}(\mathbf{s}_{a, \beta})}^{r_{a, \beta}, S_{a, \beta}, l'_{a, \beta}} \right\} \\
 &\times B_{i'_a \rightarrow \cup_{b, \alpha} l_{ba, \alpha}'' \cup_{\gamma} l_{a, \gamma}''}^{R_a \rightarrow \cup_{b, \alpha} r_{ba, \alpha} \cup_{\gamma} \bar{r}_{a, \gamma}; \nu_a^+} \left\{ \prod_{\gamma} C_{\bar{\rho}_{a, \gamma}^{-1}(\bar{\mathbf{s}}_{a, \gamma})}^{\bar{r}_{a, \gamma}, \bar{S}_{a, \gamma}, \bar{l}_{a, \gamma}''} \right\} \quad (\text{A.2.12})
 \end{aligned}$$

$$\begin{aligned}
 &= c_{\mathbf{L}} \prod_a D_{i'_a, j'_a}^{R_a}(\sigma_a) B_{j'_a \rightarrow \cup_{b, \alpha} l'_{ab, \alpha} \cup_{\beta} l'_{a, \beta}}^{R_a \rightarrow \cup_{b, \alpha} r_{ab, \alpha} \cup_{\beta} r_{a, \beta}, \nu_a^-} \prod_{\beta} C_{\rho_{a, \beta}^{-1}(\mathbf{s}_{a, \beta})}^{r_{a, \beta}, S_{a, \beta}, l'_{a, \beta}} \\
 &\quad \times B_{i'_a \rightarrow \cup_{b, \alpha} l'_{ba, \alpha} \cup_{\gamma} l_{a, \gamma}''}^{R_a \rightarrow \cup_{b, \alpha} r_{ba, \alpha} \cup_{\gamma} \bar{r}_{a, \gamma}, \nu_a^+} \prod_{\gamma} C_{\bar{r}_{a, \gamma}, \bar{S}_{a, \gamma}, \bar{l}_{a, \gamma}''}^{\bar{\rho}_{a, \gamma}^{-1}(\bar{\mathbf{s}}_{a, \gamma})} = \chi_{\mathcal{Q}}(\mathbf{L}, \bar{\rho}^{-1}(\bar{\mathbf{s}}), \bar{\sigma})
 \end{aligned}$$

Substituting $\bar{\mathbf{s}} \rightarrow \bar{\rho}(\bar{\mathbf{s}})$, we finally get

$$\chi_{\mathcal{Q}}(\mathbf{L}, \bar{\mathbf{s}}, \bar{\sigma}) = \chi_{\mathcal{Q}}(\mathbf{L}, \bar{\rho}(\bar{\mathbf{s}}), \text{Adj}_{\bar{\rho} \times \bar{\eta}}(\bar{\sigma})) \quad (\text{A.2.13})$$

Our proposition is thus proven.

A.2.2 Orthogonality relations

In this section we will prove the quiver character orthogonality equations (3.2.25) and (3.2.26).

Orthogonality in \mathbf{L}

Let us start with eq. (3.2.25):

$$\sum_{\bar{\mathbf{s}}} \sum_{\bar{\sigma}} \chi_{\mathcal{Q}}(\mathbf{L}, \bar{\mathbf{s}}, \bar{\sigma}) \chi_{\mathcal{Q}}(\tilde{\mathbf{L}}, \bar{\mathbf{s}}, \bar{\sigma}) = \delta_{\mathbf{L}, \tilde{\mathbf{L}}} \quad (\text{A.2.14})$$

This formula is actually a particular case of the more general identity

$$\begin{aligned}
 &\sum_{\bar{\mathbf{s}}} \sum_{\bar{\sigma}} \chi_{\mathcal{Q}}(\mathbf{L}, \bar{\mathbf{s}}, \bar{\sigma}^l \cdot \bar{\sigma}) \chi_{\mathcal{Q}}(\tilde{\mathbf{L}}, \bar{\mathbf{s}}, \bar{\sigma}) \\
 &= c_{\mathbf{L}} c_{\tilde{\mathbf{L}}} \prod_a \frac{n_a!}{d(R_a)} \text{Tr} \left(D^{R_a}(\sigma'_a) P_{R_a \rightarrow \cup_{b, \alpha} r_{ba, \alpha} \cup_{\gamma} \bar{r}_{a, \gamma}}^{\nu_a^+, \bar{\nu}_a^+} \right) \delta_{R_a, \tilde{R}_a} \\
 &\quad \times \left(\prod_{b, \alpha} \delta_{r_{ab, \alpha}, \tilde{r}_{ab, \alpha}} \right) \left(\prod_{\beta} d(r_{a, \beta}) \delta_{r_{a, \beta}, \tilde{r}_{a, \beta}} \delta_{S_{a, \beta}, \tilde{S}_{a, \beta}} \right) \left(\prod_{\gamma} \delta_{\bar{r}_{a, \gamma}, \tilde{\bar{r}}_{a, \gamma}} \delta_{\bar{S}_{a, \gamma}, \tilde{\bar{S}}_{a, \gamma}} \right) \delta_{\nu_a^-, \bar{\nu}_a^-}
 \end{aligned} \quad (\text{A.2.15})$$

Here $P_{R_a \rightarrow \cup_{b, \alpha} r_{ba, \alpha} \cup_{\gamma} \bar{r}_{a, \gamma}}^{\nu_a^+, \bar{\nu}_a^+}$ is a linear operator whose matrix elements are

$$P_{R_a \rightarrow \cup_{b, \alpha} r_{ba, \alpha} \cup_{\gamma} \bar{r}_{a, \gamma}}^{\nu_a^+, \bar{\nu}_a^+} \Big|_{\tilde{i}_a, \tilde{i}_a} = B_{\tilde{i}_a \rightarrow \cup_{b, \alpha} l_{ba, \alpha} \cup_{\gamma} \bar{l}_{a, \gamma}}^{R_a \rightarrow \cup_{b, \alpha} r_{ba, \alpha} \cup_{\gamma} \bar{r}_{a, \gamma}, \nu_a^+} B_{i_a \rightarrow \cup_{b, \alpha} l_{ba, \alpha} \cup_{\gamma} \bar{l}_{a, \gamma}}^{R_a \rightarrow \cup_{b, \alpha} r_{ba, \alpha} \cup_{\gamma} \bar{r}_{a, \gamma}, \nu_a^+} \quad (\text{A.2.16})$$

Let us prove eq. (A.2.15). As a first step we expanding its LHS to get

$$\begin{aligned}
 & \sum_{\vec{s}} \sum_{\vec{\sigma}} \chi_{\mathcal{Q}}(\mathbf{L}, \vec{s}, \vec{\sigma}' \cdot \vec{\sigma}) \chi_{\mathcal{Q}}(\tilde{\mathbf{L}}, \vec{s}, \vec{\sigma}) \\
 &= c_{\mathbf{L}} c_{\tilde{\mathbf{L}}} \sum_{\vec{s}} \sum_{\vec{\sigma}} \prod_a D_{i_a, j_a}^{R_a}(\sigma'_a \cdot \sigma_a) D_{\tilde{i}_a, \tilde{j}_a}^{\tilde{R}_a}(\sigma_a) \\
 & \quad \times B_{j_a \rightarrow \cup_{b, \alpha} l_{ab, \alpha} \cup_{\beta} l_{a, \beta}}^{R_a \rightarrow \cup_{b, \alpha} r_{ab, \alpha} \cup_{\beta} r_{a, \beta}; \nu_a^-} B_{\tilde{j}_a \rightarrow \cup_{b, \alpha} \tilde{l}_{ab, \alpha} \cup_{\beta} \tilde{l}_{a, \beta}}^{\tilde{R}_a \rightarrow \cup_{b, \alpha} \tilde{r}_{ab, \alpha} \cup_{\beta} \tilde{r}_{a, \beta}; \tilde{\nu}_a^-} \prod_{\beta} C_{\mathbf{s}_{a, \beta}}^{r_{a, \beta}, S_{a, \beta}, l_{a, \beta}} C_{\mathbf{s}_{a, \beta}}^{\tilde{r}_{a, \beta}, \tilde{S}_{a, \beta}, \tilde{l}_{a, \beta}} \\
 & \quad \times B_{i_a \rightarrow \cup_{b, \alpha} l_{ba, \alpha} \cup_{\gamma} \tilde{l}_{a, \gamma}}^{R_a \rightarrow \cup_{b, \alpha} r_{ba, \alpha} \cup_{\gamma} \tilde{r}_{a, \gamma}; \nu_a^+} B_{\tilde{i}_a \rightarrow \cup_{b, \alpha} \tilde{l}_{ba, \alpha} \cup_{\gamma} \tilde{l}_{a, \gamma}}^{\tilde{R}_a \rightarrow \cup_{b, \alpha} \tilde{r}_{ba, \alpha} \cup_{\gamma} \tilde{r}_{a, \gamma}; \tilde{\nu}_a^+} \prod_{\gamma} C_{\tilde{r}_{a, \gamma}, \tilde{S}_{a, \gamma}, \tilde{l}_{a, \gamma}}^{\bar{\mathbf{s}}_{a, \gamma}} C_{\tilde{r}_{a, \gamma}, \tilde{S}_{a, \gamma}, \tilde{l}_{a, \gamma}}^{\bar{\mathbf{s}}_{a, \gamma}} \quad (\text{A.2.17})
 \end{aligned}$$

The next step is to rewrite the known relation

$$\sum_{\sigma \in \mathcal{S}_n} D_{i, j}^R(\sigma) D_{p, q}^{R'}(\sigma) = \frac{n!}{d(R)} \delta_{R, R'} \delta_{i, p} \delta_{j, q} \quad (\text{A.2.18})$$

into the form

$$\begin{aligned}
 \sum_{\sigma_a} D_{i_a, j_a}^{R_a}(\sigma'_a \cdot \sigma_a) D_{\tilde{i}_a, \tilde{j}_a}^{\tilde{R}_a}(\sigma_a) &= \sum_{k_a} D_{i_a, k_a}^{R_a}(\sigma'_a) \frac{n_a!}{d(R_a)} \delta_{R_a, \tilde{R}_a} \delta_{k_a, \tilde{i}_a} \delta_{j_a, \tilde{j}_a} \\
 &= D_{i_a, \tilde{i}_a}^{R_a}(\sigma'_a) \frac{n_a!}{d(R_a)} \delta_{R_a, \tilde{R}_a} \delta_{j_a, \tilde{j}_a} \quad (\text{A.2.19})
 \end{aligned}$$

This identity can be inserted into eq. (A.2.17) to get

$$\begin{aligned}
 & \sum_{\vec{s}} \sum_{\vec{\sigma}} \chi_{\mathcal{Q}}(\mathbf{L}, \vec{s}, \vec{\sigma}' \cdot \vec{\sigma}) \chi_{\mathcal{Q}}(\tilde{\mathbf{L}}, \vec{s}, \vec{\sigma}) \\
 &= c_{\mathbf{L}} c_{\tilde{\mathbf{L}}} \sum_{\vec{s}} \prod_a \frac{n_a!}{d(R_a)} \delta_{R_a, \tilde{R}_a} D_{i_a, \tilde{i}_a}^{R_a}(\sigma'_a) \\
 & \quad \times \delta_{j_a, \tilde{j}_a} B_{j_a \rightarrow \cup_{b, \alpha} l_{ab, \alpha} \cup_{\beta} l_{a, \beta}}^{R_a \rightarrow \cup_{b, \alpha} r_{ab, \alpha} \cup_{\beta} r_{a, \beta}; \nu_a^-} B_{\tilde{j}_a \rightarrow \cup_{b, \alpha} \tilde{l}_{ab, \alpha} \cup_{\beta} \tilde{l}_{a, \beta}}^{\tilde{R}_a \rightarrow \cup_{b, \alpha} \tilde{r}_{ab, \alpha} \cup_{\beta} \tilde{r}_{a, \beta}; \tilde{\nu}_a^-} \prod_{\beta} C_{\mathbf{s}_{a, \beta}}^{r_{a, \beta}, S_{a, \beta}, l_{a, \beta}} C_{\mathbf{s}_{a, \beta}}^{\tilde{r}_{a, \beta}, \tilde{S}_{a, \beta}, \tilde{l}_{a, \beta}} \\
 & \quad \times B_{i_a \rightarrow \cup_{b, \alpha} l_{ba, \alpha} \cup_{\gamma} \tilde{l}_{a, \gamma}}^{R_a \rightarrow \cup_{b, \alpha} r_{ba, \alpha} \cup_{\gamma} \tilde{r}_{a, \gamma}; \nu_a^+} B_{\tilde{i}_a \rightarrow \cup_{b, \alpha} \tilde{l}_{ba, \alpha} \cup_{\gamma} \tilde{l}_{a, \gamma}}^{\tilde{R}_a \rightarrow \cup_{b, \alpha} \tilde{r}_{ba, \alpha} \cup_{\gamma} \tilde{r}_{a, \gamma}; \tilde{\nu}_a^+} \prod_{\gamma} C_{\tilde{r}_{a, \gamma}, \tilde{S}_{a, \gamma}, \tilde{l}_{a, \gamma}}^{\bar{\mathbf{s}}_{a, \gamma}} C_{\tilde{r}_{a, \gamma}, \tilde{S}_{a, \gamma}, \tilde{l}_{a, \gamma}}^{\bar{\mathbf{s}}_{a, \gamma}} \quad (\text{A.2.20})
 \end{aligned}$$

Now using the orthogonality relation (3.2.7) in eq. (A.2.20), we further obtain

$$\begin{aligned}
 & \sum_{\vec{s}} \sum_{\vec{\sigma}} \chi_{\mathcal{Q}}(\mathbf{L}, \vec{s}, \vec{\sigma}' \cdot \vec{\sigma}) \chi_{\mathcal{Q}}(\tilde{\mathbf{L}}, \vec{s}, \vec{\sigma}) \\
 &= c_{\mathbf{L}} c_{\tilde{\mathbf{L}}} \sum_{\vec{s}} \prod_a \frac{n_a!}{d(R_a)} \delta_{R_a, \tilde{R}_a} \left(\prod_{b, \alpha} \delta_{r_{ab, \alpha}, \tilde{r}_{ab, \alpha}} \delta_{l_{ab, \alpha}, \tilde{l}_{ab, \alpha}} \right) \delta_{\nu_a^-, \tilde{\nu}_a^-} D_{i_a, \tilde{i}_a}^{R_a}(\sigma'_a)
 \end{aligned}$$

$$\begin{aligned}
 & \times \left(\prod_{\beta} \delta_{r_{a,\beta}, \tilde{r}_{a,\beta}} \delta_{l_{a,\beta}, \tilde{l}_{a,\beta}} C_{\mathbf{s}_{a,\beta}}^{r_{a,\beta}, S_{a,\beta}, l_{a,\beta}} C_{\mathbf{s}_{a,\beta}}^{\tilde{r}_{a,\beta}, \tilde{S}_{a,\beta}, \tilde{l}_{a,\beta}} \right) \\
 & \times B_{i_a \rightarrow \cup_{b,\alpha} l_{ba,\alpha} \cup_{\gamma} \tilde{l}_{a,\gamma}}^{R_a \rightarrow \cup_{b,\alpha} r_{ba,\alpha} \cup_{\gamma} \tilde{r}_{a,\gamma}; \nu_a^+} B_{\tilde{i}_a \rightarrow \cup_{b,\alpha} \tilde{l}_{ba,\alpha} \cup_{\gamma} \tilde{l}_{a,\gamma}}^{R_a \rightarrow \cup_{b,\alpha} r_{ba,\alpha} \cup_{\gamma} \tilde{r}_{a,\gamma}; \tilde{\nu}_a^+} \prod_{\gamma} C_{\tilde{r}_{a,\gamma}, \tilde{S}_{a,\gamma}, \tilde{l}_{a,\gamma}}^{\tilde{\mathbf{s}}_{a,\gamma}} C_{\tilde{r}_{a,\gamma}, \tilde{S}_{a,\gamma}, \tilde{l}_{a,\gamma}}^{\tilde{\mathbf{s}}_{a,\gamma}} \\
 = & c_L c_{\tilde{L}} \sum_{\vec{s}} \prod_a \frac{n_a!}{d(R_a)} \delta_{R_a, \tilde{R}_a} \left(\prod_{b,\alpha} \delta_{r_{ab,\alpha}, \tilde{r}_{ab,\alpha}} \right) \left(\prod_{\beta} \delta_{r_{a,\beta}, \tilde{r}_{a,\beta}} \right) \delta_{\nu_a^-, \tilde{\nu}_a^-} D_{i_a, \tilde{i}_a}^{R_a}(\sigma'_a) \\
 & \times \prod_{\beta} C_{\mathbf{s}_{a,\beta}}^{r_{a,\beta}, S_{a,\beta}, l_{a,\beta}} C_{\mathbf{s}_{a,\beta}}^{\tilde{r}_{a,\beta}, \tilde{S}_{a,\beta}, \tilde{l}_{a,\beta}} \\
 & \times B_{i_a \rightarrow \cup_{b,\alpha} l_{ba,\alpha} \cup_{\gamma} \tilde{l}_{a,\gamma}}^{R_a \rightarrow \cup_{b,\alpha} r_{ba,\alpha} \cup_{\gamma} \tilde{r}_{a,\gamma}; \nu_a^+} B_{\tilde{i}_a \rightarrow \cup_{b,\alpha} \tilde{l}_{ba,\alpha} \cup_{\gamma} \tilde{l}_{a,\gamma}}^{R_a \rightarrow \cup_{b,\alpha} r_{ba,\alpha} \cup_{\gamma} \tilde{r}_{a,\gamma}; \tilde{\nu}_a^+} \prod_{\gamma} C_{\tilde{r}_{a,\gamma}, \tilde{S}_{a,\gamma}, \tilde{l}_{a,\gamma}}^{\tilde{\mathbf{s}}_{a,\gamma}} C_{\tilde{r}_{a,\gamma}, \tilde{S}_{a,\gamma}, \tilde{l}_{a,\gamma}}^{\tilde{\mathbf{s}}_{a,\gamma}} \quad (\text{A.2.21})
 \end{aligned}$$

Let us focus on the pair of Clebsch-Gordan coefficients $C_{\mathbf{s}_{a,\beta}}^{r_{a,\beta}, S_{a,\beta}, l_{a,\beta}} C_{\mathbf{s}_{a,\beta}}^{\tilde{r}_{a,\beta}, \tilde{S}_{a,\beta}, \tilde{l}_{a,\beta}}$ in this formula. It is immediate to verify that, for a $U(F)$ Clebsch-Gordan coefficient $C_{\mathbf{s}}^{r,S,i}$

$$\begin{aligned}
 \sum_{\mathbf{s}} C_{\mathbf{s}}^{r,S,i} C_{\mathbf{s}}^{r',S',i'} &= \sum_{\mathbf{s}} \langle r, S, i | \mathbf{s} \rangle \langle r', S', i' | \mathbf{s} \rangle = \langle r, S, i | \left(\sum_{\mathbf{s}} |\mathbf{s}\rangle \langle \mathbf{s}| \right) | r', S', i' \rangle \\
 &= \langle r, S, i | 1 | r', S', i' \rangle = \delta_{r,r'} \delta_{S,S'} \delta_{i,i'} \quad (\text{A.2.22})
 \end{aligned}$$

Therefore we can write

$$\sum_{l_{a,\beta}} \sum_{\mathbf{s}_{a,\beta}} C_{\mathbf{s}_{a,\beta}}^{r_{a,\beta}, S_{a,\beta}, l_{a,\beta}} C_{\mathbf{s}_{a,\beta}}^{\tilde{r}_{a,\beta}, \tilde{S}_{a,\beta}, \tilde{l}_{a,\beta}} = \sum_{l_{a,\beta}} \delta_{S_{a,\beta}, \tilde{S}_{a,\beta}} = d(r_{a,\beta}) \delta_{S_{a,\beta}, \tilde{S}_{a,\beta}} \quad (\text{A.2.23})$$

Inserting this in (A.2.21) we obtain

$$\begin{aligned}
 & \sum_{\vec{s}} \sum_{\vec{\sigma}} \chi_{\mathcal{Q}}(\mathbf{L}, \vec{s}, \vec{\sigma}' \cdot \vec{\sigma}) \chi_{\mathcal{Q}}(\tilde{\mathbf{L}}, \vec{s}, \vec{\sigma}) \\
 = & c_L c_{\tilde{L}} \prod_a \frac{n_a!}{d(R_a)} \delta_{R_a, \tilde{R}_a} \left(\prod_{b,\alpha} \delta_{r_{ab,\alpha}, \tilde{r}_{ab,\alpha}} \right) \left(\prod_{\beta} d(r_{a,\beta}) \delta_{r_{a,\beta}, \tilde{r}_{a,\beta}} \delta_{S_{a,\beta}, \tilde{S}_{a,\beta}} \right) \delta_{\nu_a^-, \tilde{\nu}_a^-} D_{i_a, \tilde{i}_a}^{R_a}(\sigma'_a) \\
 & \times B_{i_a \rightarrow \cup_{b,\alpha} l_{ba,\alpha} \cup_{\gamma} \tilde{l}_{a,\gamma}}^{R_a \rightarrow \cup_{b,\alpha} r_{ba,\alpha} \cup_{\gamma} \tilde{r}_{a,\gamma}; \nu_a^+} B_{\tilde{i}_a \rightarrow \cup_{b,\alpha} \tilde{l}_{ba,\alpha} \cup_{\gamma} \tilde{l}_{a,\gamma}}^{R_a \rightarrow \cup_{b,\alpha} r_{ba,\alpha} \cup_{\gamma} \tilde{r}_{a,\gamma}; \tilde{\nu}_a^+} \prod_{\gamma} \sum_{\tilde{\mathbf{s}}_{a,\gamma}} C_{\tilde{r}_{a,\gamma}, \tilde{S}_{a,\gamma}, \tilde{l}_{a,\gamma}}^{\tilde{\mathbf{s}}_{a,\gamma}} C_{\tilde{r}_{a,\gamma}, \tilde{S}_{a,\gamma}, \tilde{l}_{a,\gamma}}^{\tilde{\mathbf{s}}_{a,\gamma}} \\
 = & c_L c_{\tilde{L}} \prod_a \frac{n_a!}{d(R_a)} \delta_{R_a, \tilde{R}_a} \left(\prod_{b,\alpha} \delta_{r_{ab,\alpha}, \tilde{r}_{ab,\alpha}} \right) \left(\prod_{\beta} d(r_{a,\beta}) \delta_{r_{a,\beta}, \tilde{r}_{a,\beta}} \delta_{S_{a,\beta}, \tilde{S}_{a,\beta}} \right) \delta_{\nu_a^-, \tilde{\nu}_a^-} D_{i_a, \tilde{i}_a}^{R_a}(\sigma'_a) \\
 & \times B_{i_a \rightarrow \cup_{b,\alpha} l_{ba,\alpha} \cup_{\gamma} \tilde{l}_{a,\gamma}}^{R_a \rightarrow \cup_{b,\alpha} r_{ba,\alpha} \cup_{\gamma} \tilde{r}_{a,\gamma}; \nu_a^+} B_{\tilde{i}_a \rightarrow \cup_{b,\alpha} \tilde{l}_{ba,\alpha} \cup_{\gamma} \tilde{l}_{a,\gamma}}^{R_a \rightarrow \cup_{b,\alpha} r_{ba,\alpha} \cup_{\gamma} \tilde{r}_{a,\gamma}; \tilde{\nu}_a^+} \left(\prod_{\gamma} \delta_{\tilde{r}_{a,\gamma}, \tilde{r}_{a,\gamma}} \delta_{\tilde{S}_{a,\gamma}, \tilde{S}_{a,\gamma}} \delta_{\tilde{l}_{a,\gamma}, \tilde{l}_{a,\gamma}} \right)
 \end{aligned}$$

$$\begin{aligned}
 &= c_L c_{\tilde{L}} \prod_a \frac{n_a!}{d(R_a)} \delta_{R_a, \tilde{R}_a} \left(\prod_{b, \alpha} \delta_{r_{ab, \alpha}, \tilde{r}_{ab, \alpha}} \right) \left(\prod_{\beta} d(r_{a, \beta}) \delta_{r_{a, \beta}, \tilde{r}_{a, \beta}} \delta_{S_{a, \beta}, \tilde{S}_{a, \beta}} \right) \\
 &\quad \times \left(\prod_{\gamma} \delta_{\tilde{r}_{a, \gamma}, \tilde{r}_{a, \gamma}} \delta_{\tilde{S}_{a, \gamma}, \tilde{S}_{a, \gamma}} \right) \delta_{\nu_a^-, \tilde{\nu}_a^-} D_{i_a, \tilde{i}_a}^{R_a} (\sigma'_a) B_{i_a \rightarrow \cup_{b, \alpha} l_{ba, \alpha} \cup_{\gamma} \tilde{l}_{a, \gamma}}^{R_a \rightarrow \cup_{b, \alpha} r_{ba, \alpha} \cup_{\gamma} \tilde{r}_{a, \gamma}; \nu_a^+} B_{\tilde{i}_a \rightarrow \cup_{b, \alpha} l_{ba, \alpha} \cup_{\gamma} \tilde{l}_{a, \gamma}}^{R_a \rightarrow \cup_{b, \alpha} r_{ba, \alpha} \cup_{\gamma} \tilde{r}_{a, \gamma}; \tilde{\nu}_a^+}
 \end{aligned} \tag{A.2.24}$$

In the second equality above we again used (A.2.22):

$$\sum_{\vec{s}_{a, \gamma}} C_{\tilde{r}_{a, \gamma}, \tilde{S}_{a, \gamma}, \tilde{l}_{a, \gamma}}^{\vec{s}_{a, \gamma}} C_{\tilde{r}_{a, \gamma}, \tilde{S}_{a, \gamma}, \tilde{l}_{a, \gamma}}^{\vec{s}_{a, \gamma}} = \delta_{\tilde{r}_{a, \gamma}, \tilde{r}_{a, \gamma}} \delta_{\tilde{S}_{a, \gamma}, \tilde{S}_{a, \gamma}} \delta_{\tilde{l}_{a, \gamma}, \tilde{l}_{a, \gamma}} \tag{A.2.25}$$

We now define the projector-like operator $P_{R_a \rightarrow \cup_{b, \alpha} r_{ba, \alpha} \cup_{\gamma} \tilde{r}_{a, \gamma}}^{\nu_a^+, \tilde{\nu}_a^+}$, whose matrix elements are

$$P_{R_a \rightarrow \cup_{b, \alpha} r_{ba, \alpha} \cup_{\gamma} \tilde{r}_{a, \gamma}}^{\nu_a^+, \tilde{\nu}_a^+} \Big|_{i_a, \tilde{i}_a} = B_{i_a \rightarrow \cup_{b, \alpha} l_{ba, \alpha} \cup_{\gamma} \tilde{l}_{a, \gamma}}^{R_a \rightarrow \cup_{b, \alpha} r_{ba, \alpha} \cup_{\gamma} \tilde{r}_{a, \gamma}; \nu_a^+} B_{i_a \rightarrow \cup_{b, \alpha} l_{ba, \alpha} \cup_{\gamma} \tilde{l}_{a, \gamma}}^{R_a \rightarrow \cup_{b, \alpha} r_{ba, \alpha} \cup_{\gamma} \tilde{r}_{a, \gamma}; \tilde{\nu}_a^+} \tag{A.2.26}$$

For $\nu_a^+ = \tilde{\nu}_a^+$ the operator $P_{R_a \rightarrow \cup_{b, \alpha} r_{ba, \alpha} \cup_{\gamma} \tilde{r}_{a, \gamma}}^{\nu_a^+, \tilde{\nu}_a^+}$ is the projector on the $(\cup_{b, \alpha} r_{ba, \alpha} \cup_{\gamma} \tilde{r}_{a, \gamma}; \nu_a^+)$ subspace of R_a , but when $\nu_a^+ \neq \tilde{\nu}_a^+$ it is rather an intertwining operator mapping the copies ν_a^+ and $\tilde{\nu}_a^+$ of the same subspace $\cup_{b, \alpha} r_{ba, \alpha} \cup_{\gamma} \tilde{r}_{a, \gamma} \subset R_a$ one to another. With this definition, we can finally write

$$\begin{aligned}
 &\sum_{\vec{s}} \sum_{\vec{\sigma}} \chi_{\mathcal{Q}}(\mathbf{L}, \vec{s}, \vec{\sigma}' \cdot \vec{\sigma}) \chi_{\mathcal{Q}}(\tilde{\mathbf{L}}, \vec{s}, \vec{\sigma}) \\
 &= c_L c_{\tilde{L}} \prod_a \frac{n_a!}{d(R_a)} \text{Tr} \left(D^{R_a} (\sigma'_a) P_{R_a \rightarrow \cup_{b, \alpha} r_{ba, \alpha} \cup_{\gamma} \tilde{r}_{a, \gamma}}^{\nu_a^+, \tilde{\nu}_a^+} \right) \delta_{R_a, \tilde{R}_a} \\
 &\quad \times \left(\prod_{b, \alpha} \delta_{r_{ab, \alpha}, \tilde{r}_{ab, \alpha}} \right) \left(\prod_{\beta} d(r_{a, \beta}) \delta_{r_{a, \beta}, \tilde{r}_{a, \beta}} \delta_{S_{a, \beta}, \tilde{S}_{a, \beta}} \right) \left(\prod_{\gamma} \delta_{\tilde{r}_{a, \gamma}, \tilde{r}_{a, \gamma}} \delta_{\tilde{S}_{a, \gamma}, \tilde{S}_{a, \gamma}} \right) \delta_{\nu_a^-, \tilde{\nu}_a^-}
 \end{aligned} \tag{A.2.27}$$

which is eq. (A.2.15). Consider now the case in which $\vec{\sigma}' = \vec{1}$. Then

$$\begin{aligned}
 &\text{Tr} \left(D^{R_a} (1) P_{R_a \rightarrow \cup_{b, \alpha} r_{ba, \alpha} \cup_{\gamma} \tilde{r}_{a, \gamma}}^{\nu_a^+, \tilde{\nu}_a^+} \right) = \text{Tr} \left(P_{R_a \rightarrow \cup_{b, \alpha} r_{ba, \alpha} \cup_{\gamma} \tilde{r}_{a, \gamma}}^{\nu_a^+, \tilde{\nu}_a^+} \right) \\
 &= \sum_{\substack{l_{ba, \alpha} \\ l_{a, \gamma}}} \left(\sum_{i_a} B_{i_a \rightarrow \cup_{b, \alpha} l_{ba, \alpha} \cup_{\gamma} \tilde{l}_{a, \gamma}}^{R_a \rightarrow \cup_{b, \alpha} r_{ba, \alpha} \cup_{\gamma} \tilde{r}_{a, \gamma}; \nu_a^+} B_{i_a \rightarrow \cup_{b, \alpha} l_{ba, \alpha} \cup_{\gamma} \tilde{l}_{a, \gamma}}^{R_a \rightarrow \cup_{b, \alpha} r_{ba, \alpha} \cup_{\gamma} \tilde{r}_{a, \gamma}; \tilde{\nu}_a^+} \right) \\
 &= \delta_{\nu_a^+, \tilde{\nu}_a^+} \sum_{\substack{l_{ba, \alpha} \\ l_{a, \gamma}}} \left(\prod_{b, \alpha} \delta_{l_{ba, \alpha}, l_{ba, \alpha}} \right) \left(\prod_{\gamma} \delta_{l_{a, \gamma}, l_{a, \gamma}} \right) = \delta_{\nu_a^+, \tilde{\nu}_a^+} \left(\prod_{b, \alpha} d(r_{ba, \alpha}) \right) \left(\prod_{\gamma} d(\tilde{r}_{a, \gamma}) \right)
 \end{aligned} \tag{A.2.28}$$

where the third equality follows from the orthogonality relation (3.2.7). Using this identity in (A.2.15) we get

$$\begin{aligned}
 & \sum_{\vec{s}} \sum_{\vec{\sigma}} \chi_{\mathcal{Q}}(\mathbf{L}, \vec{s}, \vec{\sigma}) \chi_{\mathcal{Q}}(\tilde{\mathbf{L}}, \vec{s}, \vec{\sigma}) \\
 &= c_{\mathbf{L}} c_{\tilde{\mathbf{L}}} \prod_a \frac{n_a!}{d(R_a)} \delta_{R_a, \tilde{R}_a} \delta_{\nu_a^-, \tilde{\nu}_a^-} \delta_{\nu_a^+, \tilde{\nu}_a^+} \left(\prod_{b, \alpha} d(r_{ab, \alpha}) \delta_{r_{ab, \alpha}, \tilde{r}_{ab, \alpha}} \right) \\
 & \quad \times \left(\prod_{\beta} d(r_{a, \beta}) \delta_{r_{a, \beta}, \tilde{r}_{a, \beta}} \delta_{S_{a, \beta}, \tilde{S}_{a, \beta}} \right) \left(\prod_{\gamma} d(\bar{r}_{a, \gamma}) \delta_{\bar{r}_{a, \gamma}, \tilde{\bar{r}}_{a, \gamma}} \delta_{\tilde{S}_{a, \gamma}, \tilde{\tilde{S}}_{a, \gamma}} \right) \quad (\text{A.2.29})
 \end{aligned}$$

Recalling the definition of the set of labels $\mathbf{L} = \{R_a, r_{ab, \alpha}, r_{a, \beta}, S_{a, \beta}, \bar{r}_{a, \gamma}, \tilde{S}_{a, \gamma}, \nu_a^+, \nu_a^-\}$, we can thus write

$$\begin{aligned}
 & \sum_{\vec{s}} \sum_{\vec{\sigma}} \chi_{\mathcal{Q}}(\mathbf{L}, \vec{s}, \vec{\sigma}) \chi_{\mathcal{Q}}(\tilde{\mathbf{L}}, \vec{s}, \vec{\sigma}) \\
 &= \delta_{\mathbf{L}, \tilde{\mathbf{L}}} c_{\mathbf{L}} c_{\tilde{\mathbf{L}}} \prod_a \frac{n_a!}{d(R_a)} \left(\prod_{b, \alpha} d(r_{ab, \alpha}) \right) \left(\prod_{\beta} d(r_{a, \beta}) \right) \left(\prod_{\gamma} d(\bar{r}_{a, \gamma}) \right) = \delta_{\mathbf{L}, \tilde{\mathbf{L}}} \quad (\text{A.2.30})
 \end{aligned}$$

The identity (A.2.14) is proven.

Orthogonality in $\vec{s}, \vec{\sigma}$

In this section we are going to prove (3.2.26):

$$\sum_{\mathbf{L}} \chi_{\mathcal{Q}}(\mathbf{L}, \vec{s}, \vec{\sigma}) \chi_{\mathcal{Q}}(\mathbf{L}, \vec{t}, \vec{\tau}) = \frac{1}{c_{\vec{n}}} \sum_{\vec{\eta} \times \vec{\rho}} \delta(\text{Adj}_{\vec{\eta} \times \vec{\rho}}(\vec{\sigma}) \vec{\tau}^{-1}) \delta_{\vec{\rho}(\vec{s}), \vec{t}} \quad (\text{A.2.31})$$

We start by writing two useful identities, which will allow us to connect state indices appearing in the first quiver character with state indices appearing in the second quiver character. Consider contracting both sides of the equation [83]

$$\sum_{\sigma \in S_n} D_{i, j}^r(\sigma) D_{k, l}^{r'}(\sigma) = \frac{n!}{d(r)} \delta_{r, r'} \delta_{i, k} \delta_{j, l} \quad (\text{A.2.32})$$

with $B_{I \rightarrow i, \dots}^{R \rightarrow r, \dots; \nu^-} B_{J \rightarrow j, \dots}^{R \rightarrow r, \dots; \nu^+} B_{K \rightarrow k, \dots}^{R \rightarrow r', \dots; \nu^+} B_{L \rightarrow l, \dots}^{R \rightarrow r', \dots; \nu^-}$ and then summing over the representation $r' \vdash n$. By doing so, we get the identity

$$\begin{aligned}
 & B_{I \rightarrow i, \dots}^{R \rightarrow r, \dots; \nu^-} B_{K \rightarrow i, \dots}^{R \rightarrow r, \dots; \nu^+} B_{L \rightarrow l, \dots}^{R \rightarrow r, \dots; \nu^-} B_{J \rightarrow l, \dots}^{R \rightarrow r, \dots; \nu^+} \\
 &= \frac{d(r)}{n!} \sum_{\sigma \in S_n} \sum_{r' \vdash n} B_{I \rightarrow i, \dots}^{R \rightarrow r, \dots; \nu^-} B_{J \rightarrow j, \dots}^{R \rightarrow r, \dots; \nu^+} B_{K \rightarrow k, \dots}^{R \rightarrow r', \dots; \nu^+} B_{L \rightarrow l, \dots}^{R \rightarrow r', \dots; \nu^-} D_{i, j}^r(\sigma) D_{k, l}^{r'}(\sigma) \quad (\text{A.2.33})
 \end{aligned}$$

Alternatively, contracting both sides of (A.2.32) with $C_{\mathbf{s}}^{r',S,k} C_{\mathbf{t}}^{r',S,l}$ and summing over the representations $r' \vdash n$, we obtain

$$C_{\mathbf{s}}^{r,S,i} C_{\mathbf{t}}^{r,S,j} = \frac{d(r)}{n!} \sum_{\sigma \in S_n} D_{i,j}^r(\sigma) \left(\sum_{r' \vdash n} D_{k,l}^{r'}(\sigma) C_{\mathbf{s}}^{r',S,k} C_{\mathbf{t}}^{r',S,l} \right) \quad (\text{A.2.34})$$

This is the second identity we are going to need.

Let us then consider the product

$$\begin{aligned} \chi_{\mathcal{Q}}(\mathbf{L}, \vec{s}, \vec{\sigma}) \chi_{\mathcal{Q}}(\mathbf{L}, \vec{t}, \vec{\tau}) &= c_{\mathbf{L}}^2 \prod_a D_{i_a, j_a}^{R_a}(\sigma_a) D_{i'_a, j'_a}^{R_a}(\tau_a) \\ &\times B_{j_a \rightarrow \cup_{b,\alpha} r_{ab,\alpha} \cup_{\beta} r_{a,\beta}; \nu_a^-}^{R_a \rightarrow \cup_{b,\alpha} r_{ab,\alpha} \cup_{\beta} r_{a,\beta}} \left(\prod_{\beta} C_{\mathbf{s}_{a,\beta}}^{r_{a,\beta}, S_{a,\beta}, l_{a,\beta}} \right) B_{i_a \rightarrow \cup_{b,\alpha} l_{ba,\alpha} \cup_{\gamma} \bar{r}_{a,\gamma}; \nu_a^+}^{R_a \rightarrow \cup_{b,\alpha} l_{ba,\alpha} \cup_{\gamma} \bar{r}_{a,\gamma}} \left(\prod_{\gamma} C_{\bar{r}_{a,\gamma}, \bar{S}_{a,\gamma}, \bar{l}_{a,\gamma}}^{\bar{s}_{a,\gamma}} \right) \\ &\times B_{j'_a \rightarrow \cup_{b,\alpha} l'_{ab,\alpha} \cup_{\beta} l'_{a,\beta}}^{R_a \rightarrow \cup_{b,\alpha} l'_{ab,\alpha} \cup_{\beta} l'_{a,\beta}} \left(\prod_{\beta} C_{\mathbf{t}_{a,\beta}}^{r_{a,\beta}, S_{a,\beta}, l'_{a,\beta}} \right) B_{i'_a \rightarrow \cup_{b,\alpha} l'_{ba,\alpha} \cup_{\gamma} \bar{l}'_{a,\gamma}; \nu_a^+}^{R_a \rightarrow \cup_{b,\alpha} l'_{ba,\alpha} \cup_{\gamma} \bar{l}'_{a,\gamma}} \left(\prod_{\gamma} C_{\bar{r}_{a,\gamma}, \bar{S}_{a,\gamma}, \bar{l}'_{a,\gamma}}^{\bar{t}_{a,\gamma}} \right) \end{aligned} \quad (\text{A.2.35})$$

Using (A.2.33) and (A.2.34) in (A.2.35) we find

$$\begin{aligned} \chi_{\mathcal{Q}}(\mathbf{L}, \vec{s}, \vec{\sigma}) \chi_{\mathcal{Q}}(\mathbf{L}, \vec{t}, \vec{\tau}) &= c_{\mathbf{L}}^2 \sum_{\vec{\eta}, \vec{\rho}} \sum_{\{r'_{ab,\alpha}\}} \sum_{\{r'_{a,\beta}\}} \sum_{\{\bar{r}'_{a,\gamma}\}} \\ &\times \prod_a \left(\prod_{b,\alpha} \frac{d(r_{ab,\alpha})}{n_{ab,\alpha}!} \right) \left(\prod_{\beta} \frac{d(r_{a,\beta})}{n_{a,\beta}!} \right) \left(\prod_{\gamma} \frac{d(\bar{r}_{a,\gamma})}{\bar{n}_{a,\gamma}!} \right) D_{i_a, j_a}^{R_a}(\sigma_a) D_{i'_a, j'_a}^{R_a}(\tau_a) \\ &\times \left[\left(\prod_{b,\alpha} D_{p_{ab,\alpha}, p'_{ab,\alpha}}^{r_{ab,\alpha}}(\eta_{ab,\alpha}) \right) \left(\prod_{\beta} D_{p_{a,\beta}, p'_{a,\beta}}^{r_{a,\beta}}(\rho_{a,\beta}) \right) B_{j_a \rightarrow \cup_{b,\alpha} p_{ab,\alpha} \cup_{\beta} p_{a,\beta}; \nu_a^-}^{R_a \rightarrow \cup_{b,\alpha} p_{ab,\alpha} \cup_{\beta} p_{a,\beta}} \right] \\ &\times \left(\prod_{\beta} D_{q_{a,\beta}, q'_{a,\beta}}^{r'_{a,\beta}}(\rho_{a,\beta}) C_{\mathbf{s}_{a,\beta}}^{r'_{a,\beta}, S_{a,\beta}, q_{a,\beta}} C_{\mathbf{t}_{a,\beta}}^{r'_{a,\beta}, S_{a,\beta}, q'_{a,\beta}} \right) \\ &\times \left[\left(\prod_{b,\alpha} D_{q_{ba,\alpha}, q'_{ba,\alpha}}^{r'_{ba,\alpha}}(\eta_{ba,\alpha}) \right) \left(\prod_{\gamma} D_{\bar{p}_{a,\gamma}, \bar{p}'_{a,\gamma}}^{\bar{r}'_{a,\gamma}}(\bar{\rho}_{a,\gamma}) \right) B_{i_a \rightarrow \cup_{b,\alpha} q_{ba,\alpha} \cup_{\gamma} \bar{p}_{a,\gamma}; \nu_a^+}^{R_a \rightarrow \cup_{b,\alpha} q_{ba,\alpha} \cup_{\gamma} \bar{p}_{a,\gamma}} \right] \\ &\times \left(\prod_{\gamma} D_{\bar{q}_{a,\gamma}, \bar{q}'_{a,\gamma}}^{\bar{r}'_{a,\gamma}}(\bar{\rho}_{a,\gamma}) C_{\bar{r}'_{a,\gamma}, \bar{S}_{a,\gamma}, \bar{q}_{a,\gamma}}^{\bar{s}_{a,\gamma}} C_{\bar{r}'_{a,\gamma}, \bar{S}_{a,\gamma}, \bar{q}'_{a,\gamma}}^{\bar{t}_{a,\gamma}} \right) \\ &\times B_{j'_a \rightarrow \cup_{b,\alpha} p'_{ab,\alpha} \cup_{\beta} p'_{a,\beta}}^{R_a \rightarrow \cup_{b,\alpha} p'_{ab,\alpha} \cup_{\beta} p'_{a,\beta}} B_{i'_a \rightarrow \cup_{b,\alpha} q'_{ba,\alpha} \cup_{\gamma} \bar{p}'_{a,\gamma}}^{R_a \rightarrow \cup_{b,\alpha} q'_{ba,\alpha} \cup_{\gamma} \bar{p}'_{a,\gamma}} \end{aligned} \quad (\text{A.2.36})$$

where $\{r'_{ab,\alpha}\}$, $\{r'_{a,\beta}\}$ and $\{\bar{r}'_{a,\gamma}\}$ are shorthands for $\cup_{a,b,\alpha} \{r'_{ab,\alpha}\}$, $\cup_{a,\beta} \{r'_{a,\beta}\}$ and $\cup_{a,\gamma} \{\bar{r}'_{a,\gamma}\}$ re-

spectively. We now use the equivariance property of the branching coefficients (eq. (A.2.4)) to rewrite the terms in the square brackets above as

$$\begin{aligned} & \left(\prod_{b,\alpha} D_{p_{ab,\alpha}, p'_{ab,\alpha}}^{r_{ab,\alpha}}(\eta_{ab,\alpha}) \right) \left(\prod_{\beta} D_{p_{a,\beta}, p'_{a,\beta}}^{r_{a,\beta}}(\rho_{a,\beta}) \right) B_{j_a \rightarrow \cup_{b,\alpha} p_{ab,\alpha} \cup_{\beta} p_{a,\beta}}^{R_a \rightarrow \cup_{b,\alpha} r_{ab,\alpha} \cup_{\beta} r_{a,\beta}; \nu_a^-} \\ & = D_{j_a, l_a}^{R_a} (\times_{b,\alpha} \eta_{ab,\alpha} \times_{\beta} \rho_{a,\beta}) B_{l_a \rightarrow \cup_{b,\alpha} p'_{ab,\alpha} \cup_{\beta} p'_{a,\beta}}^{R_a \rightarrow \cup_{b,\alpha} r_{ab,\alpha} \cup_{\beta} r_{a,\beta}; \nu_a^-} \end{aligned} \quad (\text{A.2.37})$$

and

$$\begin{aligned} & \left(\prod_{b,\alpha} D_{q_{ba,\alpha}, q'_{ba,\alpha}}^{r'_{ba,\alpha}}(\eta_{ba,\alpha}) \right) \left(\prod_{\gamma} D_{\bar{p}_{a,\gamma}, \bar{p}'_{a,\gamma}}^{\bar{r}_{a,\gamma}}(\bar{\rho}_{a,\gamma}) \right) B_{i_a \rightarrow \cup_{b,\alpha} q_{ba,\alpha} \cup_{\gamma} \bar{p}_{a,\gamma}}^{R_a \rightarrow \cup_{b,\alpha} r'_{ba,\alpha} \cup_{\gamma} \bar{r}_{a,\gamma}; \nu_a^+} \\ & = D_{i_a, l'_a}^{R_a} (\times_{b,\alpha} \eta_{ba,\alpha} \times_{\gamma} \rho_{a,\gamma}) B_{l'_a \rightarrow \cup_{b,\alpha} q'_{ba,\alpha} \cup_{\gamma} \bar{p}'_{a,\gamma}}^{R_a \rightarrow \cup_{b,\alpha} r'_{ba,\alpha} \cup_{\gamma} \bar{r}_{a,\gamma}; \nu_a^+} \end{aligned} \quad (\text{A.2.38})$$

On the other hand, we can use eqs. (A.2.10) and (A.2.11) to write the Clebsch-Gordan coefficient terms as

$$\prod_{\beta} D_{q_{a,\beta}, q'_{a,\beta}}^{r'_{a,\beta}}(\rho_{a,\beta}) C_{\mathbf{s}_{a,\beta}}^{r'_{a,\beta}, S_{a,\beta}, q_{a,\beta}} C_{\mathbf{t}_{a,\beta}}^{r'_{a,\beta}, S_{a,\beta}, q'_{a,\beta}} = \prod_{\beta} C_{\rho_{a,\beta}^{-1}(\mathbf{s}_{a,\beta})}^{r'_{a,\beta}, S_{a,\beta}, q'_{a,\beta}} C_{\mathbf{t}_{a,\beta}}^{r'_{a,\beta}, S_{a,\beta}, q_{a,\beta}} \quad (\text{A.2.39})$$

(there is no sum over the $r_{a,\beta}$ and $S_{a,\beta}$ labels) and

$$\prod_{\gamma} D_{\bar{q}_{a,\gamma}, \bar{q}'_{a,\gamma}}^{\bar{r}'_{a,\gamma}}(\bar{\rho}_{a,\gamma}) C_{\bar{\mathbf{r}}_{a,\gamma}, \bar{S}_{a,\gamma}, \bar{q}_{a,\gamma}}^{\bar{\mathbf{s}}_{a,\gamma}} C_{\bar{\mathbf{r}}_{a,\gamma}, \bar{S}_{a,\gamma}, \bar{q}'_{a,\gamma}}^{\bar{\mathbf{t}}_{a,\gamma}} = \prod_{\gamma} C_{\bar{\mathbf{r}}_{a,\gamma}, \bar{S}_{a,\gamma}, \bar{q}'_{a,\gamma}}^{\bar{\rho}_{a,\gamma}^{-1}(\bar{\mathbf{s}}_{a,\gamma})} C_{\bar{\mathbf{r}}_{a,\gamma}, \bar{S}_{a,\gamma}, \bar{q}_{a,\gamma}}^{\bar{\mathbf{t}}_{a,\gamma}} \quad (\text{A.2.40})$$

(again no sum over the $\bar{r}_{a,\gamma}$ and $\bar{S}_{a,\gamma}$ labels).

Inserting the last four equations in (A.2.36), taking the transpose of the matrix element on the RHS of (A.2.38) and relabelling the dummy permutation variables as $\vec{\eta} \rightarrow \vec{\eta}^{-1}, \vec{\rho} \rightarrow \vec{\rho}^{-1}$ gives

$$\begin{aligned} \chi_{\mathcal{Q}}(\mathbf{L}, \vec{s}, \vec{\sigma}) \chi_{\mathcal{Q}}(\mathbf{L}, \vec{t}, \vec{\tau}) &= \frac{1}{c_{\vec{n}}} \sum_{\vec{\eta}, \vec{\rho}} \sum_{\{s_{ab,\alpha}\}} \sum_{\{s_{a,\beta}\}} \sum_{\{\bar{s}_{a,\gamma}\}} \prod_a \frac{d(R_a)}{n_a!} \\ & \times D_{l'_a, i_a}^{R_a} (\times_{b,\alpha} \eta_{ba,\alpha} \times_{\gamma} \rho_{a,\gamma}) D_{i_a, j_a}^{R_a}(\sigma_a) D_{j_a, l_a}^{R_a} (\times_{b,\alpha} \eta_{ab,\alpha}^{-1} \times_{\beta} \rho_{a,\beta}^{-1}) D_{i'_a, j'_a}^{R_a}(\tau_a) \\ & \times \left[B_{l_a \rightarrow \cup_{b,\alpha} p_{ab,\alpha} \cup_{\beta} p_{a,\beta}}^{R_a \rightarrow \cup_{b,\alpha} r_{ab,\alpha} \cup_{\beta} r_{a,\beta}; \nu_a^-} B_{j_a \rightarrow \cup_{b,\alpha} p'_{ab,\alpha} \cup_{\beta} p'_{a,\beta}}^{R_a \rightarrow \cup_{b,\alpha} r_{ab,\alpha} \cup_{\beta} r_{a,\beta}; \nu_a^-} \right] \\ & \times \left[B_{l'_a \rightarrow \cup_{b,\alpha} q'_{ba,\alpha} \cup_{\gamma} \bar{p}'_{a,\gamma}}^{R_a \rightarrow \cup_{b,\alpha} s_{ba,\alpha} \cup_{\gamma} \bar{r}_{a,\gamma}; \nu_a^+} B_{i'_a \rightarrow \cup_{b,\alpha} q_{ba,\alpha} \cup_{\gamma} \bar{p}_{a,\gamma}}^{R_a \rightarrow \cup_{b,\alpha} s_{ba,\alpha} \cup_{\gamma} \bar{r}_{a,\gamma}; \nu_a^+} \right] \\ & \times \left(\prod_{\beta} C_{\rho_{a,\beta}(\mathbf{s}_{a,\beta})}^{s_{a,\beta}, S_{a,\beta}, q_{a,\beta}} C_{\mathbf{t}_{a,\beta}}^{s_{a,\beta}, S_{a,\beta}, q_{a,\beta}} \right) \left(\prod_{\gamma} C_{\bar{s}_{a,\gamma}, \bar{S}_{a,\gamma}, \bar{q}_{a,\gamma}}^{\bar{\rho}_{a,\gamma}(\bar{\mathbf{s}}_{a,\gamma})} C_{\bar{\mathbf{r}}_{a,\gamma}, \bar{S}_{a,\gamma}, \bar{q}_{a,\gamma}}^{\bar{\mathbf{t}}_{a,\gamma}} \right) \end{aligned} \quad (\text{A.2.41})$$

where we also used the definitions of $c_{\mathbf{L}}$ and $c_{\vec{n}}$ given in (3.2.21) and (3.2.27). Now, from eq. (A.2.16) we have

$$\left[B_{l_a \rightarrow \cup_{b,\alpha} r'_{ab,\alpha} \cup_{\beta} r'_{a,\beta}}^{R_a \rightarrow \cup_{b,\alpha} r_{ab,\alpha} \cup_{\beta} r_{a,\beta}; \nu_a^-} B_{j'_a \rightarrow \cup_{b,\alpha} r'_{ab,\alpha} \cup_{\beta} r'_{a,\beta}}^{R_a \rightarrow \cup_{b,\alpha} r_{ab,\alpha} \cup_{\beta} r_{a,\beta}; \nu_a^-} \right] = P_{R_a \rightarrow \cup_{b,\alpha} r_{ab,\alpha} \cup_{\beta} r_{a,\beta}}^{\nu_a^-, \nu_a^-} \Big|_{l_a, j'_a} \quad (\text{A.2.42})$$

$$\left[B_{l'_a \rightarrow \cup_{b,\alpha} q'_{ba,\alpha} \cup_{\gamma} \bar{p}'_{a,\gamma}}^{R_a \rightarrow \cup_{b,\alpha} r'_{ba,\alpha} \cup_{\gamma} \bar{r}_{a,\gamma}; \nu_a^+} B_{i'_a \rightarrow \cup_{b,\alpha} q'_{ba,\alpha} \cup_{\gamma} \bar{p}'_{a,\gamma}}^{R_a \rightarrow \cup_{b,\alpha} r'_{ba,\alpha} \cup_{\gamma} \bar{r}_{a,\gamma}; \nu_a^+} \right] = P_{R_a \rightarrow \cup_{b,\alpha} r'_{ba,\alpha} \cup_{\gamma} \bar{r}_{a,\gamma}}^{\nu_a^+, \nu_a^+} \Big|_{l'_a, i'_a} \quad (\text{A.2.43})$$

so that we can write

$$\begin{aligned} \chi_{\mathcal{Q}}(\mathbf{L}, \vec{s}, \vec{\sigma}) \chi_{\mathcal{Q}}(\mathbf{L}, \vec{t}, \vec{\tau}) &= \frac{1}{c_{\vec{n}}} \sum_{\vec{\eta}, \vec{\rho}} \sum_{\{r'_{ab,\alpha}\}} \prod_a \frac{d(R_a)}{n_a!} D_{l'_a, l_a}^{R_a} (\text{Adj}_{\vec{\eta} \times \vec{\rho}}(\sigma_a)) D_{i'_a, j'_a}^{R_a}(\tau_a) \\ &\times P_{R_a \rightarrow \cup_{b,\alpha} r_{ab,\alpha} \cup_{\beta} r_{a,\beta}}^{\nu_a^-, \nu_a^-} \Big|_{l_a, j'_a} P_{R_a \rightarrow \cup_{b,\alpha} r'_{ba,\alpha} \cup_{\gamma} \bar{r}_{a,\gamma}}^{\nu_a^+, \nu_a^+} \Big|_{l'_a, i'_a} \\ &\times \left(\sum_{\{r'_{a,\beta}\}} \prod_{\beta} C_{\rho_{a,\beta}(\mathbf{s}_{a,\beta})}^{r'_{a,\beta}, S_{a,\beta}, q_{a,\beta}} C_{\mathbf{t}_{a,\beta}}^{r'_{a,\beta}, S_{a,\beta}, q_{a,\beta}} \right) \left(\sum_{\{\bar{r}'_{a,\gamma}\}} \prod_{\gamma} C_{\bar{r}'_{a,\gamma}, \bar{S}_{a,\gamma}, \bar{q}_{a,\gamma}}^{\bar{\rho}_{a,\gamma}(\bar{\mathbf{s}}_{a,\gamma})} C_{\bar{r}'_{a,\gamma}, \bar{S}_{a,\gamma}, \bar{q}_{a,\gamma}}^{\bar{\mathbf{t}}_{a,\gamma}} \right) \end{aligned} \quad (\text{A.2.44})$$

where we defined

$$\text{Adj}_{\vec{\eta} \times \vec{\rho}}(\sigma_a) = (\times_{b,\alpha} \eta_{ba,\alpha} \times_{\gamma} \rho_{a,\gamma})(\sigma_a) (\times_{b,\alpha} \eta_{ab,\alpha}^{-1} \times_{\beta} \rho_{a,\beta}^{-1}) \quad (\text{A.2.45})$$

Now we can proceed to sum over $\mathbf{L} = \{R_a, r_{ab,\alpha}, r_{a,\beta}, S_{a,\beta}, \bar{r}_{a,\gamma}, \bar{S}_{a,\gamma}, \nu_a^+, \nu_a^-\}$. This introduces, among others, a summation over the flavour states $S_{a,\beta}$ and $\bar{S}_{a,\gamma}$. Consider then a pair of Clebsch-Gordan coefficients like the ones appearing in the last line of eq. (A.2.44). It is easy to write the relation

$$\sum_{r,S,i} C_{\rho(\mathbf{s})}^{r,S,i} C_{\mathbf{t}}^{r,S,i} = \langle \rho(\mathbf{s}) | \left(\sum_{r,S,i} |r,S,i\rangle \langle r,S,i| \right) | \mathbf{t} \rangle = \langle \rho(\mathbf{s}) | 1 | \mathbf{t} \rangle = \delta_{\rho(\mathbf{s}), \mathbf{t}} \quad (\text{A.2.46})$$

We then have the identity

$$\sum_{r'_{a,\beta}, S_{a,\beta}, q_{a,\beta}} C_{\rho_{a,\beta}(\mathbf{s}_{a,\beta})}^{r'_{a,\beta}, S_{a,\beta}, q_{a,\beta}} C_{\mathbf{t}_{a,\beta}}^{r'_{a,\beta}, S_{a,\beta}, q_{a,\beta}} = \delta_{\rho_{a,\beta}(\mathbf{s}_{a,\beta}), \mathbf{t}_{a,\beta}} \quad (\text{A.2.47})$$

and similarly

$$\sum_{\bar{r}'_{a,\gamma}, \bar{S}_{a,\gamma}, \bar{q}_{a,\gamma}} C_{\bar{r}'_{a,\gamma}, \bar{S}_{a,\gamma}, \bar{q}_{a,\gamma}}^{\bar{\rho}_{a,\gamma}(\bar{\mathbf{s}}_{a,\gamma})} C_{\bar{r}'_{a,\gamma}, \bar{S}_{a,\gamma}, \bar{q}_{a,\gamma}}^{\bar{\mathbf{t}}_{a,\gamma}} = \delta_{\bar{\rho}_{a,\gamma}(\bar{\mathbf{s}}_{a,\gamma}), \bar{\mathbf{t}}_{a,\gamma}} \quad (\text{A.2.48})$$

Inserting this result in eq. (A.2.44) we obtain

$$\begin{aligned}
 & \sum_{\mathbf{L}} \chi_{\mathcal{Q}}(\mathbf{L}, \vec{s}, \vec{\sigma}) \chi_{\mathcal{Q}}(\mathbf{L}, \vec{t}, \vec{\tau}) \\
 &= \frac{1}{c_{\vec{n}}} \sum_{\vec{\eta}, \vec{\rho}} \prod_a \sum_{R_a} \frac{d(R_a)}{n_a!} D_{l'_a, l_a}^{R_a} (\text{Adj}_{\vec{\eta} \times \vec{\rho}}(\sigma_a)) D_{l'_a, j'_a}^{R_a}(\tau_a) \\
 & \quad \times \sum_{\cup_{b, \alpha} \{r_{ab, \alpha}\}} \sum_{\substack{\cup_{\beta} \{r_{a, \beta}\} \\ \nu_a^-}} P_{R_a \rightarrow \cup_{b, \alpha} r_{ab, \alpha} \cup_{\beta} r_{a, \beta}}^{\nu_a^-, \nu_a^-} \Big|_{l_a, j'_a} \sum_{\cup_{b, \alpha} \{r'_{ba, \alpha}\}} \sum_{\substack{\cup_{\gamma} \{\bar{r}_{a, \gamma}\} \\ \nu_a^+}} P_{R_a \rightarrow \cup_{b, \alpha} r'_{ba, \alpha} \cup_{\gamma} \bar{r}_{a, \gamma}}^{\nu_a^+, \nu_a^+} \Big|_{l'_a, i'_a} \\
 & \quad \times \left(\prod_{\beta} \delta_{\rho_{a, \beta}(\mathbf{s}_{a, \beta}), \mathbf{t}_{a, \beta}} \right) \left(\prod_{\gamma} \delta_{\bar{\rho}_{a, \gamma}(\bar{\mathbf{s}}_{a, \gamma}), \bar{\mathbf{t}}_{a, \gamma}} \right) \tag{A.2.49}
 \end{aligned}$$

Now using the projector identity

$$\sum_{\cup_i \{r_i\}, \nu} P_{R \rightarrow \cup_i r_i}^{\nu, \nu} \Big|_{k, l} = \delta_{k, l} \tag{A.2.50}$$

we further get

$$\begin{aligned}
 \sum_{\mathbf{L}} \chi_{\mathcal{Q}}(\mathbf{L}, \vec{s}, \vec{\sigma}) \chi_{\mathcal{Q}}(\mathbf{L}, \vec{t}, \vec{\tau}) &= \frac{1}{c_{\vec{n}}} \sum_{\vec{\eta}, \vec{\rho}} \prod_a \sum_{R_a} \frac{d(R_a)}{n_a!} \chi_{R_a} (\text{Adj}_{\vec{\eta} \times \vec{\rho}}(\sigma_a) \tau_a^{-1}) \\
 & \quad \times \left(\prod_{\beta} \delta_{\rho_{a, \beta}(\mathbf{s}_{a, \beta}), \mathbf{t}_{a, \beta}} \right) \left(\prod_{\gamma} \delta_{\bar{\rho}_{a, \gamma}(\bar{\mathbf{s}}_{a, \gamma}), \bar{\mathbf{t}}_{a, \gamma}} \right) \tag{A.2.51}
 \end{aligned}$$

Finally, through the identity

$$\sum_{R \vdash n} \frac{d(R)}{n!} \chi_R(\sigma) = \delta(\sigma) \tag{A.2.52}$$

we can rewrite (A.2.51) as

$$\begin{aligned}
 & \sum_{\mathbf{L}} \chi_{\mathcal{Q}}(\mathbf{L}, \vec{s}, \vec{\sigma}) \chi_{\mathcal{Q}}(\mathbf{L}, \vec{t}, \vec{\tau}) = \\
 &= \frac{1}{c_{\vec{n}}} \sum_{\vec{\eta}, \vec{\rho}} \prod_a \delta (\text{Adj}_{\vec{\eta} \times \vec{\rho}}(\sigma_a) \tau_a^{-1}) \left(\prod_{\beta} \delta_{\rho_{a, \beta}(\mathbf{s}_{a, \beta}), \mathbf{t}_{a, \beta}} \right) \left(\prod_{\gamma} \delta_{\bar{\rho}_{a, \gamma}(\bar{\mathbf{s}}_{a, \gamma}), \bar{\mathbf{t}}_{a, \gamma}} \right) \\
 &= \frac{1}{c_{\vec{n}}} \sum_{\vec{\eta}, \vec{\rho}} \delta (\text{Adj}_{\vec{\eta} \times \vec{\rho}}(\vec{\sigma}) \vec{\tau}^{-1}) \delta_{\vec{\rho}(\vec{s}), \vec{t}} \tag{A.2.53}
 \end{aligned}$$

This last equation is exactly (3.2.26).

A.3 Deriving the holomorphic gauge invariant operator ring structure constants

In this appendix we will derive the analytical expression for the holomorphic GIO ring structure constants $G_{\mathbf{L}^{(1)}, \mathbf{L}^{(2)}, \mathbf{L}^{(3)}}$, corresponding to the diagram given in Fig. 34. We will divide the computation into five main steps, for improved clarity. In the following subsection 3.4.1 we will explicitly derive the chiral ring structure constants for an $\mathcal{N} = 2$ SQCD, by using diagrammatic techniques alone.

1) The permutation basis product

In this first step we are going to rewrite the product of two operators in the permutation basis, $\mathcal{O}_{\mathcal{Q}}(\vec{n}_1, \vec{s}^{(1)}, \vec{\sigma}^{(1)}) \mathcal{O}_{\mathcal{Q}}(\vec{n}_2, \vec{s}^{(2)}, \vec{\sigma}^{(2)})$, as a single operator $\mathcal{O}_{\mathcal{Q}}(\vec{n}_3, \vec{s}^{(3)}, \vec{\sigma}^{(3)})$, specified by appropriate labels \vec{n}_3 , $\vec{s}^{(3)}$ and $\vec{\sigma}^{(3)}$. We use the defining equation (3.1.12) for $\mathcal{O}_{\mathcal{Q}}(\vec{n}, \vec{s}, \vec{\sigma})$ to write this product as

$$\begin{aligned}
 & \mathcal{O}_{\mathcal{Q}}(\vec{n}_1, \vec{s}^{(1)}, \vec{\sigma}^{(1)}) \mathcal{O}_{\mathcal{Q}}(\vec{n}_2, \vec{s}^{(2)}, \vec{\sigma}^{(2)}) \\
 &= \prod_a \left[\prod_{b, \alpha} \left(\Phi_{ab, \alpha}^{\otimes n_{ab, \alpha}^{(1)}} \right)_{J_{ab, \alpha}^{(1)}}^{I_{ab, \alpha}^{(1)}} \right] \otimes \left[\prod_{\beta} \left(Q_{a, \beta}^{\otimes n_{a, \beta}^{(1)}} \right)_{\mathbf{s}_{a, \beta}^{(1)}}^{I_{a, \beta}^{(1)}} \right] \otimes \left[\prod_{\gamma} \left(\bar{Q}_{a, \gamma}^{\otimes \bar{n}_{a, \gamma}^{(1)}} \right)_{\bar{J}_{a, \gamma}^{(1)}}^{\bar{\mathbf{s}}_{a, \gamma}^{(1)}} \right] \left(\sigma_a^{(1)} \right)_{\times_{b, \alpha} J_{ba, \alpha}^{(1)} \times_{\gamma} \bar{J}_{a, \gamma}^{(1)}}^{\times_{b, \alpha} I_{ab, \alpha}^{(1)} \times_{\beta} I_{a, \beta}^{(1)}} \\
 & \times \prod_a \left[\prod_{b, \alpha} \left(\Phi_{ab, \alpha}^{\otimes n_{ab, \alpha}^{(2)}} \right)_{J_{ab, \alpha}^{(2)}}^{I_{ab, \alpha}^{(2)}} \right] \otimes \left[\prod_{\beta} \left(Q_{a, \beta}^{\otimes n_{a, \beta}^{(2)}} \right)_{\mathbf{s}_{a, \beta}^{(2)}}^{I_{a, \beta}^{(2)}} \right] \otimes \left[\prod_{\gamma} \left(\bar{Q}_{a, \gamma}^{\otimes \bar{n}_{a, \gamma}^{(2)}} \right)_{\bar{J}_{a, \gamma}^{(2)}}^{\bar{\mathbf{s}}_{a, \gamma}^{(2)}} \right] \left(\sigma_a^{(2)} \right)_{\times_{b, \alpha} J_{ba, \alpha}^{(2)} \times_{\gamma} \bar{J}_{a, \gamma}^{(2)}}^{\times_{b, \alpha} I_{ab, \alpha}^{(2)} \times_{\beta} I_{a, \beta}^{(2)}} \\
 &= \prod_a \left[\prod_{b, \alpha} \left(\Phi_{ab, \alpha}^{\otimes (n_{ab, \alpha}^{(1)} + n_{ab, \alpha}^{(2)})} \right)_{J_{ab, \alpha}^{(1)} \times J_{ab, \alpha}^{(2)}}^{I_{ab, \alpha}^{(1)} \times I_{ab, \alpha}^{(2)}} \right] \left[\prod_{\beta} \left(Q_{a, \beta}^{\otimes (n_{a, \beta}^{(1)} + n_{a, \beta}^{(2)})} \right)_{\mathbf{s}_{a, \beta}^{(1)} \times \mathbf{s}_{a, \beta}^{(2)}}^{I_{a, \beta}^{(1)} \times I_{a, \beta}^{(2)}} \right] \\
 & \otimes \left[\prod_{\gamma} \left(\bar{Q}_{a, \gamma}^{\otimes (\bar{n}_{a, \gamma}^{(1)} + \bar{n}_{a, \gamma}^{(2)})} \right)_{\bar{J}_{a, \gamma}^{(1)} \times \bar{J}_{a, \gamma}^{(2)}}^{\bar{\mathbf{s}}_{a, \gamma}^{(1)} \times \bar{\mathbf{s}}_{a, \gamma}^{(2)}} \right] \left(\sigma_a^{(1)} \times \sigma_a^{(2)} \right)_{\times_{b, \alpha} J_{ba, \alpha}^{(1)} \times_{\gamma} \bar{J}_{a, \gamma}^{(1)} \times_{b, \alpha} J_{ba, \alpha}^{(2)} \times_{\gamma} \bar{J}_{a, \gamma}^{(2)}}^{\times_{b, \alpha} I_{ab, \alpha}^{(1)} \times_{\beta} I_{a, \beta}^{(1)} \times_{b, \alpha} I_{ab, \alpha}^{(2)} \times_{\beta} I_{a, \beta}^{(2)}}
 \end{aligned} \tag{A.3.1}$$

In the following we will continue to use the shorthand notation

$$\begin{aligned}
 |e_{i_1}, e_{i_2}, \dots, e_{i_n}\rangle &= |I\rangle, & I &= (i_1, i_2, \dots, i_n), \\
 \langle e^{j_1}, e^{j_2}, \dots, e^{j_n} | &= \langle J|, & J &= (j_1, j_2, \dots, j_n)
 \end{aligned}$$

which was already introduced in the previous sections. For each gauge node a , let us now define the λ_{a-} and λ_{a+} permutations such that

$$\lambda_{a-} \left| \times_{b, \alpha} I_{ab, \alpha}^{(1)} \times_{\beta} I_{a, \beta}^{(1)} \times_{b, \alpha} I_{ab, \alpha}^{(2)} \times_{\beta} I_{a, \beta}^{(2)} \right\rangle = \left| \times_{b, \alpha} \left(I_{ab, \alpha}^{(1)} \times I_{ab, \alpha}^{(2)} \right) \times_{\beta} \left(I_{a, \beta}^{(1)} \times I_{a, \beta}^{(2)} \right) \right\rangle \tag{A.3.2}$$

and

$$\lambda_{a+}^{-1} \left| \times_{b,\alpha} J_{ba,\alpha}^{(1)} \times_{\gamma} \bar{J}_{a,\gamma}^{(1)} \times_{b,\alpha} J_{ba,\alpha}^{(2)} \times_{\gamma} \bar{J}_{a,\gamma}^{(2)} \right\rangle = \left| \times_{b,\alpha} \left(J_{ba,\alpha}^{(1)} \times J_{ba,\alpha}^{(2)} \right) \times_{\gamma} \left(\bar{J}_{a,\gamma}^{(1)} \times \bar{J}_{a,\gamma}^{(2)} \right) \right\rangle \quad (\text{A.3.3})$$

These permutations have been chosen such that, when suitably acting on the $\sigma_a^{(1)} \times \sigma_a^{(2)}$ component of (A.3.1), the resulting term has the right index structure to match the index structure of the associated field component,

$$\left[\prod_{b,\alpha} \Phi_{ab,\alpha}^{\otimes (n_{ab,\alpha}^{(1)} + n_{ab,\alpha}^{(2)})} \right] \left[\prod_{\beta} Q_{a,\beta}^{\otimes (n_{a,\beta}^{(1)} + n_{a,\beta}^{(2)})} \right] \left[\prod_{\gamma} \bar{Q}_{a,\gamma}^{\otimes (\bar{n}_{a,\gamma}^{(1)} + \bar{n}_{a,\gamma}^{(1)})} \right] \times_{b,\alpha} \left(I_{ab,\alpha}^{(1)} \times I_{ab,\alpha}^{(2)} \right) \times_{\beta} \left(I_{a,\beta}^{(1)} \times I_{a,\beta}^{(2)} \right) \times_{b,\alpha} \left(J_{ba,\alpha}^{(1)} \times J_{ba,\alpha}^{(2)} \right) \times_{\gamma} \left(\bar{J}_{a,\gamma}^{(1)} \times \bar{J}_{a,\gamma}^{(2)} \right) \quad (\text{A.3.4})$$

We have in fact

$$\left(\sigma_a^{(1)} \times \sigma_a^{(2)} \right) \times_{b,\alpha} J_{ba,\alpha}^{(1)} \times_{\gamma} \bar{J}_{a,\gamma}^{(1)} \times_{b,\alpha} J_{ba,\alpha}^{(2)} \times_{\gamma} \bar{J}_{a,\gamma}^{(2)} \times_{b,\alpha} I_{ab,\alpha}^{(1)} \times_{\beta} I_{a,\beta}^{(1)} \times_{b,\alpha} I_{ab,\alpha}^{(2)} \times_{\beta} I_{a,\beta}^{(2)} = \left(\lambda_{a+}^{-1} \left(\sigma_a^{(1)} \times \sigma_a^{(2)} \right) \lambda_{a-}^{-1} \right) \times_{b,\alpha} \left(J_{ba,\alpha}^{(1)} \times J_{ba,\alpha}^{(2)} \right) \times_{\gamma} \left(\bar{J}_{a,\gamma}^{(1)} \times \bar{J}_{a,\gamma}^{(2)} \right) \times_{b,\alpha} \left(I_{ab,\alpha}^{(1)} \times I_{ab,\alpha}^{(2)} \right) \times_{\beta} \left(I_{a,\beta}^{(1)} \times I_{a,\beta}^{(2)} \right) \quad (\text{A.3.5})$$

The purpose of λ_{a-} and λ_{a+} is therefore to change the embedding into $[n_a]$ corresponding to the ordering of the upper (lower) $U(N_a)$ indices of the fields coming into (departing from) node a , eq. (3.1.9) (eq. (3.1.10)). It can be seen that the index structure of the RHS of (A.3.5) now matches the one in (A.3.4). Inserting (A.3.5) into (A.3.1), we then obtain

$$\mathcal{O}_{\mathcal{Q}}(\vec{n}_1, \vec{s}^{(1)}, \vec{\sigma}^{(1)}) \mathcal{O}_{\mathcal{Q}}(\vec{n}_2, \vec{s}^{(2)}, \vec{\sigma}^{(2)}) = \mathcal{O}_{\mathcal{Q}}(\vec{n}_{1+2}, \vec{s}^{(1)} \cup \vec{s}^{(2)}, \vec{\lambda}_+^{-1} \left(\vec{\sigma}^{(1)} \times \vec{\sigma}^{(2)} \right) \vec{\lambda}_-^{-1}) \quad (\text{A.3.6})$$

where

$$\begin{aligned} \vec{n}_{1+2} &= \cup_a \left\{ \cup_{b,\alpha} \{n_{ab,\alpha}^{(1)}, n_{ab,\alpha}^{(2)}\}; \cup_{\beta} \{n_{a,\beta}^{(1)}, n_{a,\beta}^{(2)}\}; \cup_{\gamma} \{\bar{n}_{a,\gamma}^{(1)}, \bar{n}_{a,\gamma}^{(2)}\} \right\}, \\ \vec{s}^{(1)} \cup \vec{s}^{(2)} &= \cup_a \{ \cup_{\beta} \{s_{a,\beta}^{(1)}, s_{a,\beta}^{(2)}\}; \cup_{\gamma} \{\bar{s}_{a,\gamma}^{(1)}, \bar{s}_{a,\gamma}^{(2)}\} \}, \\ \vec{\lambda}_+^{-1} \left(\vec{\sigma}^{(1)} \times \vec{\sigma}^{(2)} \right) \vec{\lambda}_-^{-1} &= \cup_a \{ \lambda_{a+}^{-1} \left(\sigma_a^{(1)} \times \sigma_a^{(2)} \right) \lambda_{a-}^{-1} \} \end{aligned} \quad (\text{A.3.7})$$

2) Using the inversion formula

In this step we are going to use eq. (A.3.6) to write a first expression for the $G_{\mathbf{L}^{(1)}, \mathbf{L}^{(2)}, \mathbf{L}^{(3)}}$ coefficients. Let us start from the product $\mathcal{O}_{\mathcal{Q}}(\mathbf{L}^{(1)}) \mathcal{O}_{\mathcal{Q}}(\mathbf{L}^{(2)})$, that we expand as

$$\begin{aligned} &\mathcal{O}_{\mathcal{Q}}(\mathbf{L}^{(1)}) \mathcal{O}_{\mathcal{Q}}(\mathbf{L}^{(2)}) \\ &= \sum_{\vec{s}^{(1)}, \vec{s}^{(2)}} \sum_{\vec{\sigma}^{(1)}, \vec{\sigma}^{(2)}} \chi_{\mathcal{Q}}(\mathbf{L}^{(1)}, \vec{s}^{(1)}, \vec{\sigma}^{(1)}) \chi_{\mathcal{Q}}(\mathbf{L}^{(2)}, \vec{s}^{(2)}, \vec{\sigma}^{(2)}) \mathcal{O}_{\mathcal{Q}}(\vec{n}_1, \vec{s}^{(1)}, \vec{\sigma}^{(1)}) \mathcal{O}_{\mathcal{Q}}(\vec{n}_2, \vec{s}^{(2)}, \vec{\sigma}^{(2)}) \end{aligned} \quad (\text{A.3.8})$$

Plugging eq. (A.3.6) into this equation we get

$$\begin{aligned} \mathcal{O}_{\mathcal{Q}}(\mathbf{L}^{(1)}) \mathcal{O}_{\mathcal{Q}}(\mathbf{L}^{(2)}) &= \sum_{\vec{s}^{(1)}, \vec{s}^{(2)}} \sum_{\vec{\sigma}^{(1)}, \vec{\sigma}^{(2)}} \chi_{\mathcal{Q}}(\mathbf{L}^{(1)}, \vec{s}^{(1)}, \vec{\sigma}^{(1)}) \chi_{\mathcal{Q}}(\mathbf{L}^{(2)}, \vec{s}^{(2)}, \vec{\sigma}^{(2)}) \\ &\quad \times \mathcal{O}_{\mathcal{Q}}(\vec{n}_{1+2}, \vec{s}^{(1)} \cup \vec{s}^{(2)}, \vec{\lambda}_+^{-1} (\vec{\sigma}^{(1)} \times \vec{\sigma}^{(2)}) \vec{\lambda}_-^{-1}) \end{aligned} \quad (\text{A.3.9})$$

We now use the inversion formula (3.2.32) to get

$$\begin{aligned} \mathcal{O}_{\mathcal{Q}}(\mathbf{L}^{(1)}) \mathcal{O}_{\mathcal{Q}}(\mathbf{L}^{(2)}) &= \sum_{\mathbf{L}^{(3)}} \left\{ \sum_{\vec{s}^{(1)}, \vec{s}^{(2)}} \sum_{\vec{\sigma}^{(1)}, \vec{\sigma}^{(2)}} \chi_{\mathcal{Q}}(\mathbf{L}^{(1)}, \vec{s}^{(1)}, \vec{\sigma}^{(1)}) \chi_{\mathcal{Q}}(\mathbf{L}^{(2)}, \vec{s}^{(2)}, \vec{\sigma}^{(2)}) \right. \\ &\quad \left. \times \chi_{\mathcal{Q}}(\mathbf{L}^{(3)}, \vec{s}^{(1)} \cup \vec{s}^{(2)}, \vec{\lambda}_+^{-1} (\vec{\sigma}^{(1)} \times \vec{\sigma}^{(2)}) \vec{\lambda}_-^{-1}) \right\} \mathcal{O}_{\mathcal{Q}}(\mathbf{L}^{(3)}) \end{aligned} \quad (\text{A.3.10})$$

from which we obtain an expression for $G_{\mathbf{L}^{(1)}, \mathbf{L}^{(2)}, \mathbf{L}^{(3)}}$:

$$\begin{aligned} &G_{\mathbf{L}^{(1)}, \mathbf{L}^{(2)}, \mathbf{L}^{(3)}} \\ &= \sum_{\vec{s}^{(1)}, \vec{s}^{(2)}} \sum_{\vec{\sigma}^{(1)}, \vec{\sigma}^{(2)}} \chi_{\mathcal{Q}}(\mathbf{L}^{(1)}, \vec{s}^{(1)}, \vec{\sigma}^{(1)}) \chi_{\mathcal{Q}}(\mathbf{L}^{(2)}, \vec{s}^{(2)}, \vec{\sigma}^{(2)}) \chi_{\mathcal{Q}}(\mathbf{L}^{(3)}, \vec{s}^{(1)} \cup \vec{s}^{(2)}, \vec{\lambda}_+^{-1} (\vec{\sigma}^{(1)} \times \vec{\sigma}^{(2)}) \vec{\lambda}_-^{-1}) \\ &= c_{\mathbf{L}^{(1)}} c_{\mathbf{L}^{(2)}} c_{\mathbf{L}^{(3)}} \sum_{\vec{s}^{(1)}, \vec{s}^{(2)}} \sum_{\vec{\sigma}^{(1)}, \vec{\sigma}^{(2)}} \prod_a D_{i_a^{(1)}, j_a^{(1)}}^{R_a^{(1)}}(\sigma_a^{(1)}) D_{i_a^{(2)}, j_a^{(2)}}^{R_a^{(2)}}(\sigma_a^{(2)}) D_{i_a^{(3)}, j_a^{(3)}}^{R_a^{(3)}}(\lambda_{a+}^{-1} (\sigma_a^{(1)} \times \sigma_a^{(2)}) \lambda_{a-}^{-1}) \\ &\quad \times \left(\prod_{p=1}^3 B_{j_a^{(p)} \rightarrow \cup_{b,\alpha} l_{ab,\alpha}^{(p)} \cup_{\beta} l_{a,\beta}^{(p)}}^{R_a^{(p)} \rightarrow \cup_{b,\alpha} r_{ab,\alpha}^{(p)} \cup_{\beta} r_{a,\beta}^{(p)}; \nu_a^{-(p)}} B_{i_a^{(p)} \rightarrow \cup_{b,\alpha} l_{ba,\alpha}^{(p)} \cup_{\gamma} l_{a,\gamma}^{(p)}}^{R_a^{(p)} \rightarrow \cup_{b,\alpha} r_{ba,\alpha}^{(p)} \cup_{\gamma} r_{a,\gamma}^{(p)}; \nu_a^{+(p)}} \right) \\ &\quad \times \left(\prod_{\beta} C_{\mathbf{s}_{a,\beta}^{(1)}}^{r_{a,\beta}^{(1)}, S_{a,\beta}^{(1)}, l_{a,\beta}^{(1)}} C_{\mathbf{s}_{a,\beta}^{(2)}}^{r_{a,\beta}^{(2)}, S_{a,\beta}^{(2)}, l_{a,\beta}^{(2)}} C_{\mathbf{s}_{a,\beta}^{(3)}}^{r_{a,\beta}^{(3)}, S_{a,\beta}^{(3)}, l_{a,\beta}^{(3)}} \right) \left(\prod_{\gamma} C_{\bar{r}_{a,\gamma}, \bar{S}_{a,\gamma}, \bar{l}_{a,\gamma}}^{\bar{\mathbf{s}}_{a,\gamma}^{(1)}} C_{\bar{r}_{a,\gamma}, \bar{S}_{a,\gamma}, \bar{l}_{a,\gamma}}^{\bar{\mathbf{s}}_{a,\gamma}^{(2)}} C_{\bar{r}_{a,\gamma}, \bar{S}_{a,\gamma}, \bar{l}_{a,\gamma}}^{\bar{\mathbf{s}}_{a,\gamma}^{(1)} \cup \bar{\mathbf{s}}_{a,\gamma}^{(2)}} \right) \end{aligned} \quad (\text{A.3.11})$$

3) Fusing of gauge edges

At this stage the chiral ring structure constants are given as a product of three definite quantities, *i.e.* three quiver characters. We now proceed to fuse together their gauge edges, by using standard representation theory identities. Let us then focus on the permutation dependent

piece of eq. (A.3.11), namely

$$\begin{aligned}
 & \sum_{\vec{\sigma}^{(1)}, \vec{\sigma}^{(2)}} \prod_a D_{i_a^{(1)}, j_a^{(1)}}^{R_a^{(1)}}(\sigma_a^{(1)}) D_{i_a^{(2)}, j_a^{(2)}}^{R_a^{(2)}}(\sigma_a^{(2)}) D_{i_a^{(3)}, j_a^{(3)}}^{R_a^{(3)}}(\lambda_{a+}^{-1} (\sigma_a^{(1)} \times \sigma_a^{(2)}) \lambda_{a-}^{-1}) \\
 &= \sum_{\vec{\sigma}^{(1)}, \vec{\sigma}^{(2)}} \prod_a D_{i_a^{(1)}, j_a^{(1)}}^{R_a^{(1)}}(\sigma_a^{(1)}) D_{i_a^{(2)}, j_a^{(2)}}^{R_a^{(2)}}(\sigma_a^{(2)}) D_{i_a^{(3)}, h_a^{(3)}}^{R_a^{(3)}}(\lambda_{a+}^{-1}) D_{h_a^{(3)}, g_a^{(3)}}^{R_a^{(3)}}(\sigma_a^{(1)} \times \sigma_a^{(2)}) D_{g_a^{(3)}, j_a^{(3)}}^{R_a^{(3)}}(\lambda_{a-}^{-1})
 \end{aligned} \tag{A.3.12}$$

Using the identity

$$D_{ij}^R(\sigma^{(1)} \times \sigma^{(2)}) = \sum_{r_1, r_2, \mu} B_{i \rightarrow l_1, l_2}^{R \rightarrow r_1, r_2; \mu} B_{j \rightarrow k_1, k_2}^{R \rightarrow r_1, r_2; \mu} D_{l_1, k_1}^{r_1}(\sigma^{(1)}) D_{l_2, k_2}^{r_2}(\sigma^{(2)}) \tag{A.3.13}$$

we can write

$$\begin{aligned}
 & \sum_{\vec{\sigma}^{(1)}, \vec{\sigma}^{(2)}} \prod_a D_{i_a^{(1)}, j_a^{(1)}}^{R_a^{(1)}}(\sigma_a^{(1)}) D_{i_a^{(2)}, j_a^{(2)}}^{R_a^{(2)}}(\sigma_a^{(2)}) D_{i_a^{(3)}, h_a^{(3)}}^{R_a^{(3)}}(\lambda_{a+}^{-1}) D_{h_a^{(3)}, g_a^{(3)}}^{R_a^{(3)}}(\sigma_a^{(1)} \times \sigma_a^{(2)}) D_{g_a^{(3)}, j_a^{(3)}}^{R_a^{(3)}}(\lambda_{a-}^{-1}) \\
 &= \sum_{\vec{\sigma}^{(1)}, \vec{\sigma}^{(2)}} \prod_a D_{i_a^{(1)}, j_a^{(1)}}^{R_a^{(1)}}(\sigma_a^{(1)}) D_{i_a^{(2)}, j_a^{(2)}}^{R_a^{(2)}}(\sigma_a^{(2)}) D_{i_a^{(3)}, h_a^{(3)}}^{R_a^{(3)}}(\lambda_{a+}^{-1}) D_{g_a^{(3)}, j_a^{(3)}}^{R_a^{(3)}}(\lambda_{a-}^{-1}) \\
 &\quad \times \left(\sum_{S_a^{(1)}, S_a^{(2)}, \mu_a} B_{h_a^{(3)} \rightarrow l_a^{(1)}, l_a^{(2)}}^{R_a^{(3)} \rightarrow S_a^{(1)}, S_a^{(2)}; \mu_a} B_{g_a^{(3)} \rightarrow k_a^{(1)}, k_a^{(2)}}^{R_a^{(3)} \rightarrow S_a^{(1)}, S_a^{(2)}; \mu_a} D_{l_a^{(1)}, k_a^{(1)}}^{S_a^{(1)}}(\sigma_a^{(1)}) D_{l_a^{(2)}, k_a^{(2)}}^{S_a^{(2)}}(\sigma_a^{(2)}) \right) \\
 &= \prod_a \frac{n_a^{(1)}! n_a^{(2)}!}{d(R_a^{(1)}) d(R_a^{(2)})} D_{i_a^{(3)}, h_a^{(3)}}^{R_a^{(3)}}(\lambda_{a+}^{-1}) D_{g_a^{(3)}, j_a^{(3)}}^{R_a^{(3)}}(\lambda_{a-}^{-1}) \\
 &\quad \times \sum_{S_a^{(1)}, S_a^{(2)}, \mu_a} B_{h_a^{(3)} \rightarrow l_a^{(1)}, l_a^{(2)}}^{R_a^{(3)} \rightarrow S_a^{(1)}, S_a^{(2)}; \mu_a} B_{g_a^{(3)} \rightarrow k_a^{(1)}, k_a^{(2)}}^{R_a^{(3)} \rightarrow S_a^{(1)}, S_a^{(2)}; \mu_a} \prod_{q=1}^2 \delta_{R_a^{(q)}, S_a^{(q)}} \delta_{i_a^{(q)}, l_a^{(q)}} \delta_{j_a^{(q)}, k_a^{(q)}} \\
 &= \prod_a \frac{n_a^{(1)}! n_a^{(2)}!}{d(R_a^{(1)}) d(R_a^{(2)})} \\
 &\quad \times \sum_{\mu_a} \left(D_{i_a^{(3)}, h_a^{(3)}}^{R_a^{(3)}}(\lambda_{a+}^{-1}) B_{h_a^{(3)} \rightarrow i_a^{(1)}, i_a^{(2)}}^{R_a^{(3)} \rightarrow R_a^{(1)}, R_a^{(2)}; \mu_a} \right) \left(D_{j_a^{(3)}, g_a^{(3)}}^{R_a^{(3)}}(\lambda_{a-}^{-1}) B_{g_a^{(3)} \rightarrow j_a^{(1)}, j_a^{(2)}}^{R_a^{(3)} \rightarrow R_a^{(1)}, R_a^{(2)}; \mu_a} \right)
 \end{aligned} \tag{A.3.14}$$

where in the second equality we used

$$\sum_{\sigma \in S_n} D_{ij}^R(\sigma) D_{kl}^S(\sigma) = \frac{n!}{d(R)} \delta_{R,S} \delta_{i,k} \delta_{j,l} \tag{A.3.15}$$

It is important to stress that all the steps that we will be describing in this appendix can be also interpreted diagrammatically. For example, (A.3.14) can be understood through the diagram in Fig. 44.

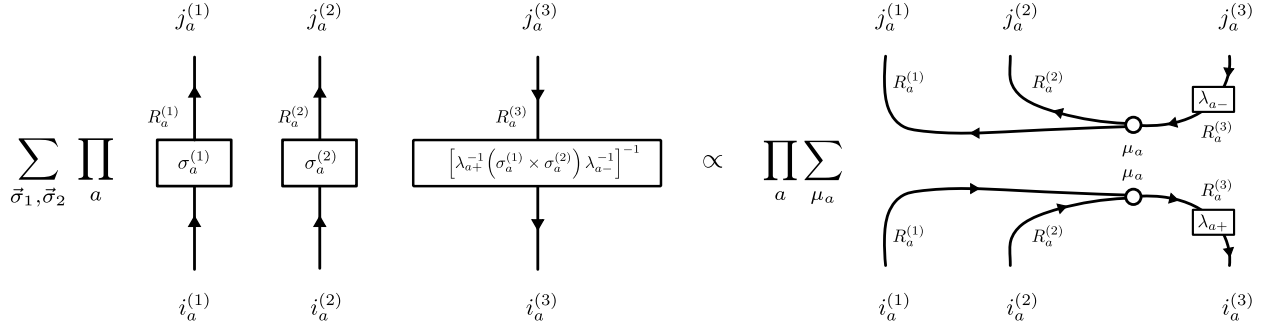

Figure 44: Diagrammatic interpretation of eq. (A.3.14).

Similar pictures can be drawn for all the following steps. In equation (A.3.14) (or equivalently, in Fig. 44) we see the emergence of the first of the selection rules already anticipated in section 3.4. This selection rule is expressed by the terms

$$B_{h_a^{(3)} \rightarrow i_a^{(1)}, i_a^{(2)}}^{R_a^{(3)} \rightarrow R_a^{(1)}, R_a^{(2)}; \mu_a}, \quad B_{g_a^{(3)} \rightarrow j_a^{(1)}, j_a^{(2)}}^{R_a^{(3)} \rightarrow R_a^{(1)}, R_a^{(2)}; \mu_a} \quad (\text{A.3.16})$$

These coefficients are non-zero only if the restriction of the $S_{n_1+n_2}$ representation $R_a^{(3)}$ to $S_{n_1} \times S_{n_2}$ contains the representation $R_a^{(1)} \otimes R_a^{(2)}$, $\forall a$.

4) Fusing of the quark/antiquark edges

In this step we will perform the fusing of the edges corresponding to the fundamental/anti-fundamental matter fields. This involves summing over the quark/antiquark states $\mathbf{s}_{a,\beta}^{(1,2)}$ and $\bar{\mathbf{s}}_{a,\gamma}^{(1,2)}$. Let us then turn to the Clebsch-Gordan parts of equation (A.3.11), that is

$$\sum_{\mathbf{s}_{a,\beta}^{(1)}, \mathbf{s}_{a,\beta}^{(2)}} C_{\mathbf{s}_{a,\beta}^{(1)}}^{r_{a,\beta}^{(1)}, S_{a,\beta}^{(1)}, l_{a,\beta}^{(1)}} C_{\mathbf{s}_{a,\beta}^{(2)}}^{r_{a,\beta}^{(2)}, S_{a,\beta}^{(2)}, l_{a,\beta}^{(2)}} C_{\mathbf{s}_{a,\beta}^{(1)} \cup \mathbf{s}_{a,\beta}^{(2)}}^{r_{a,\beta}^{(3)}, S_{a,\beta}^{(3)}, l_{a,\beta}^{(3)}} \quad (\text{A.3.17})$$

and

$$\sum_{\bar{\mathbf{s}}_{a,\gamma}^{(1)}, \bar{\mathbf{s}}_{a,\gamma}^{(2)}} C_{\bar{r}_{a,\gamma}^{(1)}, \bar{S}_{a,\gamma}^{(1)}, \bar{l}_{a,\gamma}^{(1)}}^{\bar{\mathbf{s}}_{a,\gamma}^{(1)}} C_{\bar{r}_{a,\gamma}^{(2)}, \bar{S}_{a,\gamma}^{(2)}, \bar{l}_{a,\gamma}^{(2)}}^{\bar{\mathbf{s}}_{a,\gamma}^{(2)}} C_{\bar{r}_{a,\gamma}^{(3)}, \bar{S}_{a,\gamma}^{(3)}, \bar{l}_{a,\gamma}^{(3)}}^{\bar{\mathbf{s}}_{a,\gamma}^{(1)} \cup \bar{\mathbf{s}}_{a,\gamma}^{(2)}} \quad (\text{A.3.18})$$

Consider for example the former. Aiming at simplifying notation, we rewrite it here dropping the a, β labels:

$$\sum_{\mathbf{s}^{(1)}, \mathbf{s}^{(2)}} C_{\mathbf{s}^{(1)}}^{r^{(1)}, S^{(1)}, l^{(1)}} C_{\mathbf{s}^{(2)}}^{r^{(2)}, S^{(2)}, l^{(2)}} C_{\mathbf{s}^{(1)} \cup \mathbf{s}^{(2)}}^{r^{(3)}, S^{(3)}, l^{(3)}} \quad (\text{A.3.19})$$

We can expand this quantity as

$$\begin{aligned}
 & \sum_{\mathbf{s}^{(1)}, \mathbf{s}^{(2)}} C_{\mathbf{s}^{(1)}}^{r^{(1)}, S^{(1)}, l^{(1)}} C_{\mathbf{s}^{(2)}}^{r^{(2)}, S^{(2)}, l^{(2)}} C_{\mathbf{s}^{(1)} \cup \mathbf{s}^{(2)}}^{r^{(3)}, S^{(3)}, l^{(3)}} \\
 &= \sum_{\mathbf{s}^{(1)}, \mathbf{s}^{(2)}} \langle r^{(1)}, S^{(1)}, l^{(1)} | \mathbf{s}^{(1)} \rangle \langle r^{(2)}, S^{(2)}, l^{(2)} | \mathbf{s}^{(2)} \rangle \langle r^{(3)}, S^{(3)}, l^{(3)} | \mathbf{s}^{(1)} \cup \mathbf{s}^{(2)} \rangle \\
 &= \sum_{\mathbf{s}^{(1)}, \mathbf{s}^{(2)}} \left(\langle r^{(1)}, S^{(1)}, l^{(1)} | \otimes \langle r^{(2)}, S^{(2)}, l^{(2)} | \right) \left(|\mathbf{s}^{(1)}\rangle \otimes |\mathbf{s}^{(2)}\rangle \right) \langle r^{(3)}, S^{(3)}, l^{(3)} | \mathbf{s}^{(1)} \cup \mathbf{s}^{(2)} \rangle \\
 &= \langle r^{(1)}, S^{(1)}, l^{(1)} | \otimes \langle r^{(2)}, S^{(2)}, l^{(2)} | \left(\sum_{\mathbf{s}^{(1)}, \mathbf{s}^{(2)}} |\mathbf{s}^{(1)}\rangle \otimes |\mathbf{s}^{(2)}\rangle \langle \mathbf{s}^{(1)} | \otimes \langle \mathbf{s}^{(2)} | \right) | r^{(3)}, S^{(3)}, l^{(3)} \rangle \\
 &= \left(\langle r^{(1)}, S^{(1)}, l^{(1)} | \otimes \langle r^{(2)}, S^{(2)}, l^{(2)} | \right) | r^{(3)}, S^{(3)}, l^{(3)} \rangle \\
 &= \langle \{r^{(1)}, r^{(2)}\}, \{S^{(1)}, S^{(2)}\}, \{l^{(1)}, l^{(2)}\} | r^{(3)}, S^{(3)}, l^{(3)} \rangle
 \end{aligned} \tag{A.3.20}$$

Since the generic state $|r, S, l\rangle \in V_r^{S_n} \otimes V_r^{U(F)}$ is by definition the tensor product $|r, S, l\rangle = |r, S\rangle \otimes |r, l\rangle$, we may separately decompose the two states $|r^{(3)}, S^{(3)}, l^{(3)}\rangle$ and $\{|r^{(1)}, r^{(2)}\}, \{S^{(1)}, S^{(2)}\}, \{l^{(1)}, l^{(2)}\}\rangle$ as follows. We factorise the former according to the decomposition (3.2.3), which in this case reads

$$V_{r^{(3)}}^{S_{n^{(3)}}} = \bigoplus_{u^{(1)} \vdash n^{(1)}} \bigoplus_{u^{(2)} \vdash n^{(2)}} \left(V_{u^{(1)}}^{S_{n^{(1)}}} \otimes V_{u^{(2)}}^{S_{n^{(2)}}} \right) \otimes V_{r^{(3)}}^{u^{(1)}, u^{(2)}} \tag{A.3.21}$$

We then write

$$\begin{aligned}
 |r^{(3)}, S^{(3)}, l^{(3)}\rangle &= |r^{(3)}, S^{(3)}\rangle \otimes |r^{(3)}, l^{(3)}\rangle \\
 &= \sum_{u^{(1)}, u^{(2)}} \sum_{p^{(1)}, p^{(2)}} \sum_{\nu} B_{l^{(3)} \rightarrow p^{(1)}, p^{(2)}}^{r^{(3)} \rightarrow u^{(1)}, u^{(2)}; \nu} |r^{(3)}, S^{(3)}\rangle \otimes |\{u^{(1)}, u^{(2)}\}, \{p^{(1)}, p^{(2)}\}; \nu\rangle \\
 &= \sum_{u^{(1)}, u^{(2)}} \sum_{p^{(1)}, p^{(2)}} \sum_{\nu} B_{l^{(3)} \rightarrow p^{(1)}, p^{(2)}}^{r^{(3)} \rightarrow u^{(1)}, u^{(2)}; \nu} |\{u^{(1)}, u^{(2)}, r^{(3)}\}, \{p^{(1)}, p^{(2)}\}, S^{(3)}; \nu\rangle
 \end{aligned} \tag{A.3.22}$$

For the latter we use instead the the unitary group decomposition (3.2.9), which in this case takes the explicit form

$$V_{r^{(1)}}^{U(F)} \otimes V_{r^{(2)}}^{U(F)} = \bigoplus_{u^{(3)} \vdash n^{(3)}} V_{u^{(3)}}^{U(F)} \otimes V_{u^{(3)}}^{r^{(1)}, r^{(2)}}, \quad n^{(3)} = n^{(1)} + n^{(2)} \tag{A.3.23}$$

We therefore have

$$\begin{aligned}
 \left| \{r^{(1)}, r^{(2)}\}, \{S^{(1)}, S^{(2)}\}, \{l^{(1)}, l^{(2)}\} \right\rangle &= \left| \{r^{(1)}, r^{(2)}\}, \{S^{(1)}, S^{(2)}\} \right\rangle \otimes \left| \{r^{(1)}, r^{(2)}\}, \{l^{(1)}, l^{(2)}\} \right\rangle \\
 &= \sum_{u^{(3)}} \sum_{P^{(3)}} \sum_{\tilde{\nu}} C_{P^{(3)} \rightarrow S^{(1)}, S^{(2)}}^{u^{(3)}; \tilde{\nu} \rightarrow r^{(1)}, r^{(2)}} \left| u^{(3)}, P^{(3)}; \tilde{\nu} \right\rangle \otimes \left| \{r^{(1)}, r^{(2)}\}, \{l^{(1)}, l^{(2)}\} \right\rangle \\
 &= \sum_{u^{(3)}} \sum_{P^{(3)}} \sum_{\tilde{\nu}} C_{P^{(3)} \rightarrow S^{(1)}, S^{(2)}}^{u^{(3)}; \tilde{\nu} \rightarrow r^{(1)}, r^{(2)}} \left| \{r^{(1)}, r^{(2)}, u^{(3)}\}, \{l^{(1)}, l^{(2)}\}, P^{(3)}; \tilde{\nu} \right\rangle \quad (\text{A.3.24})
 \end{aligned}$$

The vector spaces $V_{r^{(3)}}^{u^{(1)}, u^{(2)}}$ in (A.3.21) and $V_{u^{(3)}}^{r^{(1)}, r^{(2)}}$ in (A.3.23) are both multiplicity vector spaces. We recall that $\dim(V_{r^{(3)}}^{r^{(1)}, r^{(2)}}) = g(r^{(1)}, r^{(2)}; r^{(3)})$, where g is the Littlewood-Richardson coefficient. Notice that both the states on the far RHSs of (A.3.22) and (A.3.24) live in the tensor space \mathcal{W} , where

$$\mathcal{W} = V_{r^{(1)}}^{S^{(1)}} \otimes V_{r^{(2)}}^{S^{(2)}} \otimes V_{r^{(3)}}^{U(F)} \otimes V_{r^{(3)}}^{r^{(1)}, r^{(2)}} \quad (\text{A.3.25})$$

Taking the scalar product of (A.3.22) and (A.3.23) then gives

$$\begin{aligned}
 \langle \{r^{(1)}, r^{(2)}\}, \{S^{(1)}, S^{(2)}\}, \{l^{(1)}, l^{(2)}\} | r^{(3)}, S^{(3)}, l^{(3)} \rangle \\
 &= \left(\prod_{k=1}^3 \sum_{u^{(k)}} \right) \left(\prod_{q=1}^2 \sum_{p^{(q)}} \right) \sum_{P^{(3)}} \sum_{\nu, \tilde{\nu}} B_{l^{(3)} \rightarrow p^{(1)}, p^{(2)}}^{r^{(3)} \rightarrow u^{(1)}, u^{(2)}; \nu} C_{P^{(3)} \rightarrow S^{(1)}, S^{(2)}}^{u^{(3)}; \tilde{\nu} \rightarrow r^{(1)}, r^{(2)}} \\
 &\quad \times \left(\prod_{k=1}^3 \delta_{r^{(k)}, u^{(k)}} \right) \left(\prod_{q=1}^2 \delta_{l^{(q)}, p^{(q)}} \right) \delta_{S^{(3)}, P^{(3)}} \delta_{\nu, \tilde{\nu}} \\
 &= \sum_{\nu} B_{l^{(3)} \rightarrow l^{(1)}, l^{(2)}}^{r^{(3)} \rightarrow r^{(1)}, r^{(2)}; \nu} C_{S^{(3)} \rightarrow S^{(1)}, S^{(2)}}^{r^{(3)}; \nu \rightarrow r^{(1)}, r^{(2)}} \quad (\text{A.3.26})
 \end{aligned}$$

We conclude that

$$\sum_{\mathbf{s}^{(1)}, \mathbf{s}^{(2)}} C_{\mathbf{s}^{(1)}}^{r^{(1)}, S^{(1)}, l^{(1)}} C_{\mathbf{s}^{(2)}}^{r^{(2)}, S^{(2)}, l^{(2)}} C_{\mathbf{s}^{(1)} \cup \mathbf{s}^{(2)}}^{r^{(3)}, S^{(3)}, l^{(3)}} = \sum_{\nu} B_{l^{(3)} \rightarrow l^{(1)}, l^{(2)}}^{r^{(3)} \rightarrow r^{(1)}, r^{(2)}; \nu} C_{S^{(3)} \rightarrow S^{(1)}, S^{(2)}}^{r^{(3)}; \nu \rightarrow r^{(1)}, r^{(2)}} \quad (\text{A.3.27})$$

The diagrammatic interpretation of eq. (A.3.27) is drawn in Fig. 45.

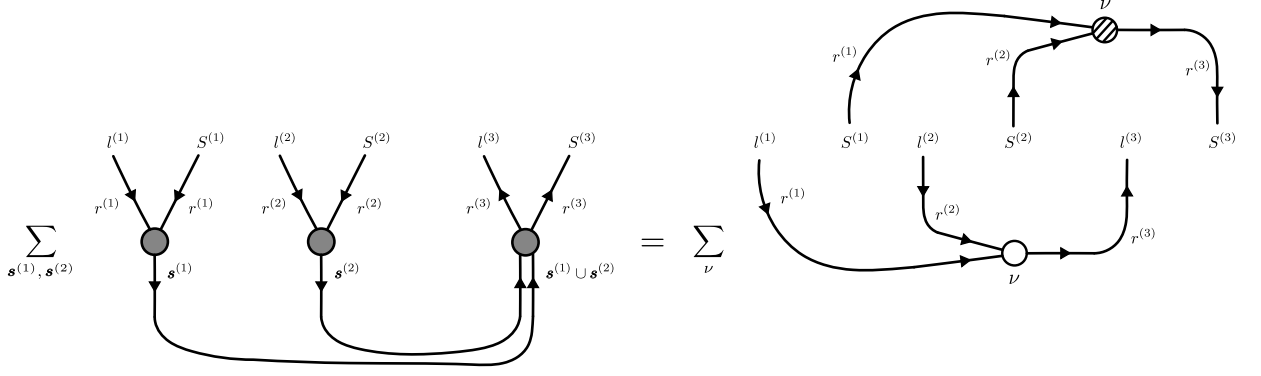

Figure 45: Diagrammatic interpretation of eq. (A.3.27).

Reintroducing the a, β notation, we then obtain

$$\sum_{\mathbf{s}_{a,\beta}^{(1)}, \mathbf{s}_{a,\beta}^{(2)}} C_{\mathbf{s}_{a,\beta}^{(1)}}^{r_{a,\beta}^{(1)}, S_{a,\beta}^{(1)}, l_{a,\beta}^{(1)}} C_{\mathbf{s}_{a,\beta}^{(2)}}^{r_{a,\beta}^{(2)}, S_{a,\beta}^{(2)}, l_{a,\beta}^{(2)}} C_{\mathbf{s}_{a,\beta}^{(1)} \cup \mathbf{s}_{a,\beta}^{(2)}}^{r_{a,\beta}^{(3)}, S_{a,\beta}^{(3)}, l_{a,\beta}^{(3)}} = \sum_{\nu_{a,\beta}} B_{l_{a,\beta}^{(3)} \rightarrow l_{a,\beta}^{(1)}, l_{a,\beta}^{(2)}}^{r_{a,\beta}^{(3)} \rightarrow r_{a,\beta}^{(1)}, r_{a,\beta}^{(2)}; \nu_{a,\beta}} C_{S_{a,\beta}^{(3)} \rightarrow S_{a,\beta}^{(1)}, S_{a,\beta}^{(2)}}^{r_{a,\beta}^{(3)}; \nu_{a,\beta} \rightarrow r_{a,\beta}^{(1)}, r_{a,\beta}^{(2)}} \quad (\text{A.3.28})$$

Similarly, we can show that for (A.3.18)

$$\sum_{\bar{\mathbf{s}}_{a,\gamma}^{(1)}, \bar{\mathbf{s}}_{a,\gamma}^{(2)}} C_{\bar{\mathbf{s}}_{a,\gamma}^{(1)}}^{\bar{r}_{a,\gamma}^{(1)}, \bar{S}_{a,\gamma}^{(1)}, \bar{l}_{a,\gamma}^{(1)}} C_{\bar{\mathbf{s}}_{a,\gamma}^{(2)}}^{\bar{r}_{a,\gamma}^{(2)}, \bar{S}_{a,\gamma}^{(2)}, \bar{l}_{a,\gamma}^{(2)}} C_{\bar{\mathbf{s}}_{a,\gamma}^{(1)} \cup \bar{\mathbf{s}}_{a,\gamma}^{(2)}}^{\bar{r}_{a,\gamma}^{(3)}, \bar{S}_{a,\gamma}^{(3)}, \bar{l}_{a,\gamma}^{(3)}} = \sum_{\bar{\nu}_{a,\gamma}} B_{\bar{l}_{a,\gamma}^{(3)} \rightarrow \bar{l}_{a,\gamma}^{(1)}, \bar{l}_{a,\gamma}^{(2)}}^{\bar{r}_{a,\gamma}^{(3)} \rightarrow \bar{r}_{a,\gamma}^{(1)}, \bar{r}_{a,\gamma}^{(2)}; \bar{\nu}_{a,\gamma}} C_{\bar{S}_{a,\gamma}^{(3)} \rightarrow \bar{S}_{a,\gamma}^{(1)}, \bar{S}_{a,\gamma}^{(2)}}^{\bar{r}_{a,\gamma}^{(3)}; \bar{\nu}_{a,\gamma} \rightarrow \bar{r}_{a,\gamma}^{(1)}, \bar{r}_{a,\gamma}^{(2)}} \quad (\text{A.3.29})$$

From eq. (A.3.28) and (A.3.29) (or equivalently by considering Fig. 45) one can see the manifestation of another selection rule for the holomorphic GIO ring structure constants. In particular, the coefficients $B_{l_{a,\beta}^{(3)} \rightarrow l_{a,\beta}^{(1)}, l_{a,\beta}^{(2)}}^{r_{a,\beta}^{(3)} \rightarrow r_{a,\beta}^{(1)}, r_{a,\beta}^{(2)}; \nu_{a,\beta}}$ are identically zero if the restriction of the $S_{n_{a,\beta}^{(1)} + n_{a,\beta}^{(2)}}$ representation $r_{a,\beta}^{(3)}$ to $S_{n_{a,\beta}^{(1)}} \times S_{n_{a,\beta}^{(2)}}$ does not contain the representation $r_{a,\beta}^{(1)} \otimes r_{a,\beta}^{(2)}$. A similar condition holds for the coefficients $B_{\bar{l}_{a,\gamma}^{(3)} \rightarrow \bar{l}_{a,\gamma}^{(1)}, \bar{l}_{a,\gamma}^{(2)}}^{\bar{r}_{a,\gamma}^{(3)} \rightarrow \bar{r}_{a,\gamma}^{(1)}, \bar{r}_{a,\gamma}^{(2)}; \bar{\nu}_{a,\gamma}}$.

Inserting eqs. (A.3.14), (A.3.28) and (A.3.29) into (A.3.11) we then get

$$\begin{aligned} G_{\mathbf{L}^{(1)}, \mathbf{L}^{(2)}, \mathbf{L}^{(3)}} &= c_{\mathbf{L}^{(1)}} c_{\mathbf{L}^{(2)}} c_{\mathbf{L}^{(3)}} \prod_a \frac{n_a^{(1)}! n_a^{(2)}!}{d(R_a^{(1)}) d(R_a^{(2)})} \\ &\times \sum_{\mu_a} \left(D_{i_a^{(3)}, h_a^{(3)}}^{R_a^{(3)}} (\lambda_{a+}) B_{h_a^{(3)} \rightarrow i_a^{(1)}, i_a^{(2)}}^{R_a^{(3)} \rightarrow R_a^{(1)}, R_a^{(2)}; \mu_a} \right) \left(D_{j_a^{(3)}, g_a^{(3)}}^{R_a^{(3)}} (\lambda_{a-}) B_{g_a^{(3)} \rightarrow j_a^{(1)}, j_a^{(2)}}^{R_a^{(3)} \rightarrow R_a^{(1)}, R_a^{(2)}; \mu_a} \right) \\ &\times \left(\prod_{p=1}^3 B_{j_a^{(p)} \rightarrow \cup_{b,\alpha} l_{ab,\alpha}^{(p)} \cup \beta l_{a,\beta}^{(p)}}^{R_a^{(p)} \rightarrow \cup_{b,\alpha} r_{ab,\alpha}^{(p)} \cup \beta r_{a,\beta}^{(p)}; \nu_a^{-(p)}} B_{i_a^{(p)} \rightarrow \cup_{b,\alpha} l_{ba,\alpha}^{(p)} \cup \gamma \bar{l}_{a,\gamma}^{(p)}}^{R_a^{(p)} \rightarrow \cup_{b,\alpha} r_{ba,\alpha}^{(p)} \cup \gamma \bar{r}_{a,\gamma}^{(p)}; \nu_a^{+(p)}} \right) \end{aligned}$$

$$\begin{aligned}
 & \times \left(\prod_{\beta} \sum_{\nu_{a,\beta}} B_{l_{a,\beta}^{(3)} \rightarrow l_{a,\beta}^{(1)}, l_{a,\beta}^{(2)}}^{\gamma_{a,\beta}^{(3)} \rightarrow r_{a,\beta}^{(1)}, r_{a,\beta}^{(2)}; \nu_{a,\beta}} C_{S_{a,\beta}^{(3)} \rightarrow S_{a,\beta}^{(1)}, S_{a,\beta}^{(2)}}^{r_{a,\beta}^{(3)}; \nu_{a,\beta} \rightarrow r_{a,\beta}^{(1)}, r_{a,\beta}^{(2)}} \right) \\
 & \times \left(\prod_{\gamma} \sum_{\bar{\nu}_{a,\gamma}} B_{\bar{l}_{a,\gamma}^{(3)} \rightarrow \bar{l}_{a,\gamma}^{(1)}, \bar{l}_{a,\gamma}^{(2)}}^{\bar{\gamma}_{a,\gamma}^{(3)} \rightarrow \bar{r}_{a,\gamma}^{(1)}, \bar{r}_{a,\gamma}^{(2)}; \bar{\nu}_{a,\gamma}} C_{\bar{S}_{a,\gamma}^{(3)} \rightarrow \bar{S}_{a,\gamma}^{(1)}, \bar{S}_{a,\gamma}^{(2)}}^{\bar{r}_{a,\gamma}^{(3)}; \bar{\nu}_{a,\gamma} \rightarrow \bar{r}_{a,\gamma}^{(1)}, \bar{r}_{a,\gamma}^{(2)}} \right) \tag{A.3.30}
 \end{aligned}$$

5) Fusing the bi-fundamental edges and factorising the \pm nodes

The two tasks of this last step are to fuse the edges corresponding to the bi-fundamental fields and to factorise the positive and negative node of the split-node quiver. We start by considering the product

$$D_{j_a^{(3)}, g_a^{(3)}}^{R_a^{(3)}}(\lambda_{a-}) B_{g_a^{(3)} \rightarrow j_a^{(1)}, j_a^{(2)}}^{R_a^{(3)} \rightarrow R_a^{(1)}, R_a^{(2)}; \mu_a} \left(\prod_{p=1}^3 B_{j_a^{(p)} \rightarrow \cup_{b,\alpha} l_{ab,\alpha}^{(p)} \cup_{\beta} l_{a,\beta}^{(p)}}^{R_a^{(p)} \rightarrow \cup_{b,\alpha} r_{ab,\alpha}^{(p)} \cup_{\beta} r_{a,\beta}^{(p)}; \nu_a^{-(p)}} \right) \tag{A.3.31}$$

which appears in eq. (A.3.30). We want to decompose this term into a product of branching coefficients of the form $B_{l_{ab,\alpha}^{(3)} \rightarrow l_{ab,\alpha}^{(1)}, l_{ab,\alpha}^{(2)}}^{r_{ab,\alpha}^{(3)} \rightarrow r_{ab,\alpha}^{(1)}, r_{ab,\alpha}^{(2)}}$.

First we notice that the equivariance property of the branching coefficients

$$D_{k,j}^R(\times_a \gamma_a) B_{j \rightarrow \cup_a l_a}^{R \rightarrow \cup_a r_a; \nu_a} = \left(\prod_a D_{l_a, l_a}^{r_a}(\gamma_a) \right) B_{k \rightarrow \cup_a l_a}^{R \rightarrow \cup_a r_a; \nu_a} \tag{A.3.32}$$

also implies

$$B_{i \rightarrow \cup_a l_a}^{R \rightarrow \cup_a r_a; \nu_a} = D_{i,k}^R(\times_a \gamma_a) \left(\prod_a D_{l_a, l_a}^{r_a}(\gamma_a) \right) B_{k \rightarrow \cup_a l_a}^{R \rightarrow \cup_a r_a; \nu_a} \tag{A.3.33}$$

for a collection of permutations $\cup_a \{\gamma_a \in S_{n_a}\}$, where each r_a is a partition of the integer n_a . We can use this identity to write (A.3.31) as

$$\begin{aligned}
 & D_{j_a^{(3)}, g_a^{(3)}}^{R_a^{(3)}}(\lambda_{a-}) B_{g_a^{(3)} \rightarrow j_a^{(1)}, j_a^{(2)}}^{R_a^{(3)} \rightarrow R_a^{(1)}, R_a^{(2)}; \mu_a} \left(\prod_{p=1}^3 B_{j_a^{(p)} \rightarrow \cup_{b,\alpha} l_{ab,\alpha}^{(p)} \cup_{\beta} l_{a,\beta}^{(p)}}^{R_a^{(p)} \rightarrow \cup_{b,\alpha} r_{ab,\alpha}^{(p)} \cup_{\beta} r_{a,\beta}^{(p)}; \nu_a^{-(p)}} \right) \\
 & = \left(D_{j_a^{(1)}, k_a^{(1)}}^{R_a^{(1)}}(\times_{b,\alpha} \eta_{ab,\alpha}^{(1)} \times 1) D_{j_a^{(2)}, k_a^{(2)}}^{R_a^{(2)}}(\times_{b,\alpha} \eta_{ab,\alpha}^{(2)} \times 1) \right. \\
 & \quad \times D_{j_a^{(3)}, k_a^{(3)}}^{R_a^{(3)}} \left(\lambda_{a-} \left(\times_{b,\alpha} \eta_{ab,\alpha}^{(1)} \times 1 \times_{b,\alpha} \eta_{ab,\alpha}^{(2)} \times 1 \right) \right) B_{k_a^{(3)} \rightarrow k_a^{(1)}, k_a^{(2)}}^{R_a^{(3)} \rightarrow R_a^{(1)}, R_a^{(2)}; \mu_a} \\
 & \quad \times \left(\prod_{p=1}^3 B_{j_a^{(p)} \rightarrow \cup_{b,\alpha} l_{ab,\alpha}^{(p)} \cup_{\beta} l_{a,\beta}^{(p)}}^{R_a^{(p)} \rightarrow \cup_{b,\alpha} r_{ab,\alpha}^{(p)} \cup_{\beta} r_{a,\beta}^{(p)}; \nu_a^{-(p)}} \right) \tag{A.3.34}
 \end{aligned}$$

where $(\times_{b,\alpha} \eta_{ab,\alpha}^{(p)} \times 1) \in S_{n_a^{(p)}}$ and $\eta_{ab,\alpha}^{(p)} \in S_{n_{ab,\alpha}^{(p)}}$, for $p = 1, 2$.

Let us now go back to the equation defining the λ_{a-} permutations, (A.3.2). It is easy to see that

$$\lambda_{a-} \left(\times_{b,\alpha} \eta_{ab,\alpha}^{(1)} \times_{\beta} \rho_{a,\beta}^{(1)} \times_{b,\alpha} \eta_{ab,\alpha}^{(2)} \times_{\beta} \rho_{a,\beta}^{(2)} \right) = \left[\times_{b,\alpha} \left(\eta_{ab,\alpha}^{(1)} \times \eta_{ab,\alpha}^{(2)} \right) \times_{\beta} \left(\rho_{a,\beta}^{(1)} \times \rho_{a,\beta}^{(2)} \right) \right] \lambda_{a-} \quad (\text{A.3.35})$$

We can use this identity in (A.3.34) to get

$$\begin{aligned} & D_{j_a^{(3)}, g_a^{(3)}}^{R_a^{(3)}} (\lambda_{a-}) B_{g_a^{(3)} \rightarrow j_a^{(1)}, j_a^{(2)}}^{R_a^{(3)} \rightarrow R_a^{(1)}, R_a^{(2)}; \mu_a} \left(\prod_{p=1}^3 B_{j_a^{(p)} \rightarrow \cup_{b,\alpha} r_{ab,\alpha}^{(p)} \cup_{\beta} r_{a,\beta}^{(p)}; \nu_a^{-(p)}}^{R_a^{(p)} \rightarrow \cup_{b,\alpha} r_{ab,\alpha}^{(p)} \cup_{\beta} r_{a,\beta}^{(p)}} \right) \\ &= \left(D_{j_a^{(1)}, k_a^{(1)}}^{R_a^{(1)}} (\times_{b,\alpha} \eta_{ab,\alpha}^{(1)} \times 1) D_{j_a^{(2)}, k_a^{(2)}}^{R_a^{(2)}} (\times_{b,\alpha} \eta_{ab,\alpha}^{(2)} \times 1) \right. \\ &\quad \times D_{j_a^{(3)}, k_a^{(3)}}^{R_a^{(3)}} \left(\left(\times_{b,\alpha} \left(\eta_{ab,\alpha}^{(1)} \times \eta_{ab,\alpha}^{(2)} \right) \times 1 \right) \lambda_{a-} \right) B_{k_a^{(3)} \rightarrow k_a^{(1)}, k_a^{(2)}}^{R_a^{(3)} \rightarrow R_a^{(1)}, R_a^{(2)}; \mu_a} \left. \right) \\ &\quad \times \left(\prod_{p=1}^3 B_{j_a^{(p)} \rightarrow \cup_{b,\alpha} l_{ab,\alpha}^{(p)} \cup_{\beta} l_{a,\beta}^{(p)}}^{R_a^{(p)} \rightarrow \cup_{b,\alpha} r_{ab,\alpha}^{(p)} \cup_{\beta} r_{a,\beta}^{(p)}; \nu_a^{-(p)}} \right) \end{aligned} \quad (\text{A.3.36})$$

Next we use the identity (A.3.32) in eq. (A.3.36) as follows, for $p = 1, 2$:

$$\begin{aligned} & D_{j_a^{(p)}, k_a^{(p)}}^{R_a^{(p)}} (\times_{b,\alpha} \eta_{ab,\alpha}^{(p)} \times 1) B_{j_a^{(p)} \rightarrow \cup_{b,\alpha} l_{ab,\alpha}^{(p)} \cup_{\beta} l_{a,\beta}^{(p)}}^{R_a^{(p)} \rightarrow \cup_{b,\alpha} r_{ab,\alpha}^{(p)} \cup_{\beta} r_{a,\beta}^{(p)}; \nu_a^{-(p)}} \\ &= \left(\prod_{b,\alpha} D_{l_{ab,\alpha}^{(p)}, q_{ab,\alpha}^{(p)}}^{r_{ab,\alpha}^{(p)}} \left(\eta_{ab,\alpha}^{(p)} \right) \right) \left(\prod_{\beta} \delta_{l_{a,\beta}^{(p)}, q_{a,\beta}^{(p)}} \right) B_{k_a^{(p)} \rightarrow \cup_{b,\alpha} q_{ab,\alpha}^{(p)} \cup_{\beta} q_{a,\beta}^{(p)}}^{R_a^{(p)} \rightarrow \cup_{b,\alpha} r_{ab,\alpha}^{(p)} \cup_{\beta} r_{a,\beta}^{(p)}; \nu_a^{-(p)}} \\ &= \left(\prod_{b,\alpha} D_{l_{ab,\alpha}^{(p)}, q_{ab,\alpha}^{(p)}}^{r_{ab,\alpha}^{(p)}} \left(\eta_{ab,\alpha}^{(p)} \right) \right) B_{k_a^{(p)} \rightarrow \cup_{b,\alpha} q_{ab,\alpha}^{(p)} \cup_{\beta} l_{a,\beta}^{(p)}}^{R_a^{(p)} \rightarrow \cup_{b,\alpha} r_{ab,\alpha}^{(p)} \cup_{\beta} r_{a,\beta}^{(p)}; \nu_a^{-(p)}} \end{aligned} \quad (\text{A.3.37})$$

Similarly, we use (A.3.32) also for the term

$$\begin{aligned} & D_{j_a^{(3)}, k_a^{(3)}}^{R_a^{(3)}} \left(\left(\times_{b,\alpha} \left(\eta_{ab,\alpha}^{(1)} \times \eta_{ab,\alpha}^{(2)} \right) \times 1 \right) \lambda_{a-} \right) B_{j_a^{(3)} \rightarrow \cup_{b,\alpha} l_{ab,\alpha}^{(3)} \cup_{\beta} l_{a,\beta}^{(3)}}^{R_a^{(3)} \rightarrow \cup_{b,\alpha} r_{ab,\alpha}^{(3)} \cup_{\beta} r_{a,\beta}^{(3)}; \nu_a^{-(3)}} \\ &= D_{g_a^{(3)}, k_a^{(3)}}^{R_a^{(3)}} (\lambda_{a-}) D_{j_a^{(3)}, g_a^{(3)}}^{R_a^{(3)}} \left(\times_{b,\alpha} \left(\eta_{ab,\alpha}^{(1)} \times \eta_{ab,\alpha}^{(2)} \right) \times 1 \right) B_{j_a^{(3)} \rightarrow \cup_{b,\alpha} l_{ab,\alpha}^{(3)} \cup_{\beta} l_{a,\beta}^{(3)}}^{R_a^{(3)} \rightarrow \cup_{b,\alpha} r_{ab,\alpha}^{(3)} \cup_{\beta} r_{a,\beta}^{(3)}; \nu_a^{-(3)}} \\ &= D_{g_a^{(3)}, k_a^{(3)}}^{R_a^{(3)}} (\lambda_{a-}) \left(\prod_{b,\alpha} D_{l_{ab,\alpha}^{(3)}, q_{ab,\alpha}^{(3)}}^{r_{ab,\alpha}^{(3)}} \left(\eta_{ab,\alpha}^{(1)} \times \eta_{ab,\alpha}^{(2)} \right) \right) B_{g_a^{(3)} \rightarrow \cup_{b,\alpha} q_{ab,\alpha}^{(3)} \cup_{\beta} l_{a,\beta}^{(3)}}^{R_a^{(3)} \rightarrow \cup_{b,\alpha} r_{ab,\alpha}^{(3)} \cup_{\beta} r_{a,\beta}^{(3)}; \nu_a^{-(3)}} \end{aligned} \quad (\text{A.3.38})$$

Putting these last equations together, we get to

$$\begin{aligned}
 & D_{j_a^{(3)}, g_a^{(3)}}^{R_a^{(3)}}(\lambda_{a-}) B_{g_a^{(3)} \rightarrow j_a^{(1)}, j_a^{(2)}}^{R_a^{(3)} \rightarrow R_a^{(1)}, R_a^{(2)}; \mu_a} \left(\prod_{p=1}^3 B_{j_a^{(p)} \rightarrow \cup_{b,\alpha} r_{ab,\alpha}^{(p)} \cup_{\beta} r_{a,\beta}^{(p)}; \nu_a^{-(p)}}^{R_a^{(p)}} \right) \\
 &= \left(\prod_{b,\alpha} D_{l_{ab,\alpha}^{(1)}, q_{ab,\alpha}^{(1)}}^{r_{ab,\alpha}^{(1)}} \left(\eta_{ab,\alpha}^{(1)} \right) D_{l_{ab,\alpha}^{(2)}, q_{ab,\alpha}^{(2)}}^{r_{ab,\alpha}^{(2)}} \left(\eta_{ab,\alpha}^{(2)} \right) D_{l_{ab,\alpha}^{(3)}, q_{ab,\alpha}^{(3)}}^{r_{ab,\alpha}^{(3)}} \left(\eta_{ab,\alpha}^{(1)} \times \eta_{ab,\alpha}^{(2)} \right) \right) B_{k_a^{(3)} \rightarrow k_a^{(1)}, k_a^{(2)}}^{R_a^{(3)} \rightarrow R_a^{(1)}, R_a^{(2)}; \mu_a} \\
 & \quad \times \left[D_{g_a^{(3)}, k_a^{(3)}}^{R_a^{(3)}}(\lambda_{a-}) B_{g_a^{(3)} \rightarrow \cup_{b,\alpha} r_{ab,\alpha}^{(3)} \cup_{\beta} r_{a,\beta}^{(3)}; \nu_a^{-(3)}}^{R_a^{(3)}} \right] \prod_{p=1}^2 B_{k_a^{(p)} \rightarrow \cup_{b,\alpha} r_{ab,\alpha}^{(p)} \cup_{\beta} r_{a,\beta}^{(p)}; \nu_a^{-(p)}}^{R_a^{(p)}} \quad (\text{A.3.39})
 \end{aligned}$$

Notice that the quantity on the LHS above is independent of the permutations η . We can then sum over all possible permutations η on the RHS, provided we divide by the number of permutations themselves: we thus obtain

$$\begin{aligned}
 & D_{j_a^{(3)}, g_a^{(3)}}^{R_a^{(3)}}(\lambda_{a-}) B_{g_a^{(3)} \rightarrow j_a^{(1)}, j_a^{(2)}}^{R_a^{(3)} \rightarrow R_a^{(1)}, R_a^{(2)}; \mu_a} \left(\prod_{p=1}^3 B_{j_a^{(p)} \rightarrow \cup_{b,\alpha} r_{ab,\alpha}^{(p)} \cup_{\beta} r_{a,\beta}^{(p)}; \nu_a^{-(p)}}^{R_a^{(p)}} \right) \\
 &= \frac{1}{\prod_{b,\alpha} n_{ab,\alpha}^{(1)}! n_{ab,\alpha}^{(2)}!} \left\{ \sum_{\cup_{b,\alpha} \{\eta_{b,\alpha}^{(1)}, \eta_{b,\alpha}^{(2)}\}} \prod_{b,\alpha} D_{l_{ab,\alpha}^{(1)}, q_{ab,\alpha}^{(1)}}^{r_{ab,\alpha}^{(1)}} \left(\eta_{ab,\alpha}^{(1)} \right) D_{l_{ab,\alpha}^{(2)}, q_{ab,\alpha}^{(2)}}^{r_{ab,\alpha}^{(2)}} \left(\eta_{ab,\alpha}^{(2)} \right) \right. \\
 & \quad \left. \times D_{l_{ab,\alpha}^{(3)}, q_{ab,\alpha}^{(3)}}^{r_{ab,\alpha}^{(3)}} \left(\eta_{ab,\alpha}^{(1)} \times \eta_{ab,\alpha}^{(2)} \right) \right\} B_{k_a^{(3)} \rightarrow k_a^{(1)}, k_a^{(2)}}^{R_a^{(3)} \rightarrow R_a^{(1)}, R_a^{(2)}; \mu_a} \\
 & \quad \times \left[D_{g_a^{(3)}, k_a^{(3)}}^{R_a^{(3)}}(\lambda_{a-}) B_{g_a^{(3)} \rightarrow \cup_{b,\alpha} r_{ab,\alpha}^{(3)} \cup_{\beta} r_{a,\beta}^{(3)}; \nu_a^{-(3)}}^{R_a^{(3)}} \right] \prod_{p=1}^2 B_{k_a^{(p)} \rightarrow \cup_{b,\alpha} r_{ab,\alpha}^{(p)} \cup_{\beta} r_{a,\beta}^{(p)}; \nu_a^{-(p)}}^{R_a^{(p)}} \quad (\text{A.3.40})
 \end{aligned}$$

The quantity inside the curly brackets above has the same structure of the far LHS of eq. (A.3.14). Performing similar steps to the ones presented in that equation we obtain, dropping the a, b, α notation for improved clarity

$$\begin{aligned}
 & \sum_{\eta^{(1)}, \eta^{(2)}} D_{l^{(1)}, q^{(1)}}^{r^{(1)}} \left(\eta^{(1)} \right) D_{l^{(2)}, q^{(2)}}^{r^{(2)}} \left(\eta^{(2)} \right) D_{l^{(3)}, q^{(3)}}^{r^{(3)}} \left(\eta^{(1)} \times \eta^{(2)} \right) \\
 &= \frac{n^{(1)}! n^{(2)}!}{d(r^{(1)}) d(r^{(2)})} \sum_{\nu} B_{l^{(3)} \rightarrow l^{(1)}, l^{(2)}}^{r^{(3)} \rightarrow r^{(1)}, r^{(2)}; \nu} B_{q^{(3)} \rightarrow q^{(1)}, q^{(2)}}^{r^{(3)} \rightarrow r^{(1)}, r^{(2)}; \nu} \quad (\text{A.3.41})
 \end{aligned}$$

Inserting this identity in (A.3.40) we get

$$\begin{aligned}
 & D_{j_a^{(3)}, g_a^{(3)}}^{R_a^{(3)}}(\lambda_{a-}) B_{g_a^{(3)} \rightarrow j_a^{(1)}, j_a^{(2)}}^{R_a^{(3)} \rightarrow R_a^{(1)}, R_a^{(2)}; \mu_a} \left(\prod_{p=1}^3 B_{j_a^{(p)} \rightarrow \cup_{b,\alpha} r_{ab,\alpha}^{(p)} \cup_{\beta} r_{a,\beta}^{(p)}; \nu_a^{-(p)}}^{R_a^{(p)} \rightarrow \cup_{b,\alpha} r_{ab,\alpha}^{(p)} \cup_{\beta} r_{a,\beta}^{(p)}} \right) \\
 &= \sum_{\cup_{b,\alpha} \{\nu_{ab,\alpha}\}} \left\{ \prod_{b,\alpha} \frac{1}{d(r_{ab,\alpha}^{(1)}) d(r_{ab,\alpha}^{(2)})} B_{l_{ab,\alpha}^{(3)} \rightarrow l_{ab,\alpha}^{(1)}, l_{ab,\alpha}^{(2)}}^{r_{ab,\alpha}^{(3)} \rightarrow r_{ab,\alpha}^{(1)}, r_{ab,\alpha}^{(2)}; \nu_{ab,\alpha}} B_{q_{ab,\alpha}^{(3)} \rightarrow q_{ab,\alpha}^{(1)}, q_{ab,\alpha}^{(2)}}^{r_{ab,\alpha}^{(3)} \rightarrow r_{ab,\alpha}^{(1)}, r_{ab,\alpha}^{(2)}; \nu_{ab,\alpha}} \right\} B_{k_a^{(3)} \rightarrow k_a^{(1)}, k_a^{(2)}}^{R_a^{(3)} \rightarrow R_a^{(1)}, R_a^{(2)}; \mu_a} \\
 & \quad \times \left[D_{g_a^{(3)}, k_a^{(3)}}^{R_a^{(3)}}(\lambda_{a-}) B_{g_a^{(3)} \rightarrow \cup_{b,\alpha} r_{ab,\alpha}^{(3)} \cup_{\beta} r_{a,\beta}^{(3)}; \nu_a^{-(3)}}^{R_a^{(3)} \rightarrow \cup_{b,\alpha} r_{ab,\alpha}^{(3)} \cup_{\beta} r_{a,\beta}^{(3)}} \right] \prod_{p=1}^2 B_{k_a^{(p)} \rightarrow \cup_{b,\alpha} q_{ab,\alpha}^{(p)} \cup_{\beta} l_{a,\beta}^{(p)}}^{R_a^{(p)} \rightarrow \cup_{b,\alpha} r_{ab,\alpha}^{(p)} \cup_{\beta} r_{a,\beta}^{(p)}; \nu_a^{-(p)}}
 \end{aligned} \tag{A.3.42}$$

Using the substitutions $k_a^{(3)} \rightarrow t_a^{(3)}$ and $g_a^{(3)} \rightarrow k_a^{(3)}$ we can then write

$$\begin{aligned}
 & D_{j_a^{(3)}, g_a^{(3)}}^{R_a^{(3)}}(\lambda_{a-}) B_{g_a^{(3)} \rightarrow j_a^{(1)}, j_a^{(2)}}^{R_a^{(3)} \rightarrow R_a^{(1)}, R_a^{(2)}; \mu_a} \left(\prod_{p=1}^3 B_{j_a^{(p)} \rightarrow \cup_{b,\alpha} r_{ab,\alpha}^{(p)} \cup_{\beta} r_{a,\beta}^{(p)}; \nu_a^{-(p)}}^{R_a^{(p)} \rightarrow \cup_{b,\alpha} r_{ab,\alpha}^{(p)} \cup_{\beta} r_{a,\beta}^{(p)}} \right) \\
 &= \sum_{\cup_{b,\alpha} \{\nu_{ab,\alpha}\}} \left\{ \prod_{b,\alpha} \frac{1}{d(r_{ab,\alpha}^{(1)}) d(r_{ab,\alpha}^{(2)})} B_{l_{ab,\alpha}^{(3)} \rightarrow l_{ab,\alpha}^{(1)}, l_{ab,\alpha}^{(2)}}^{r_{ab,\alpha}^{(3)} \rightarrow r_{ab,\alpha}^{(1)}, r_{ab,\alpha}^{(2)}; \nu_{ab,\alpha}} B_{q_{ab,\alpha}^{(3)} \rightarrow q_{ab,\alpha}^{(1)}, q_{ab,\alpha}^{(2)}}^{r_{ab,\alpha}^{(3)} \rightarrow r_{ab,\alpha}^{(1)}, r_{ab,\alpha}^{(2)}; \nu_{ab,\alpha}} \right\} \\
 & \quad \times B_{t_a^{(3)} \rightarrow k_a^{(1)}, k_a^{(2)}}^{R_a^{(3)} \rightarrow R_a^{(1)}, R_a^{(2)}; \mu_a} \left[D_{k_a^{(3)}, t_a^{(3)}}^{R_a^{(3)}}(\lambda_{a-}) B_{k_a^{(3)} \rightarrow \cup_{b,\alpha} r_{ab,\alpha}^{(3)} \cup_{\beta} r_{a,\beta}^{(3)}; \nu_a^{-(3)}}^{R_a^{(3)} \rightarrow \cup_{b,\alpha} r_{ab,\alpha}^{(3)} \cup_{\beta} r_{a,\beta}^{(3)}} \right] \\
 & \quad \times \prod_{p=1}^2 B_{k_a^{(p)} \rightarrow \cup_{b,\alpha} q_{ab,\alpha}^{(p)} \cup_{\beta} l_{a,\beta}^{(p)}}^{R_a^{(p)} \rightarrow \cup_{b,\alpha} r_{ab,\alpha}^{(p)} \cup_{\beta} r_{a,\beta}^{(p)}; \nu_a^{-(p)}} \\
 &= \sum_{\cup_{b,\alpha} \{\nu_{ab,\alpha}\}} \left\{ \prod_{b,\alpha} \frac{1}{d(r_{ab,\alpha}^{(1)}) d(r_{ab,\alpha}^{(2)})} B_{l_{ab,\alpha}^{(3)} \rightarrow l_{ab,\alpha}^{(1)}, l_{ab,\alpha}^{(2)}}^{r_{ab,\alpha}^{(3)} \rightarrow r_{ab,\alpha}^{(1)}, r_{ab,\alpha}^{(2)}; \nu_{ab,\alpha}} B_{q_{ab,\alpha}^{(3)} \rightarrow q_{ab,\alpha}^{(1)}, q_{ab,\alpha}^{(2)}}^{r_{ab,\alpha}^{(3)} \rightarrow r_{ab,\alpha}^{(1)}, r_{ab,\alpha}^{(2)}; \nu_{ab,\alpha}} \right\} \\
 & \quad \times D_{k_a^{(3)}, t_a^{(3)}}^{R_a^{(3)}}(\lambda_{a-}) B_{t_a^{(3)} \rightarrow k_a^{(1)}, k_a^{(2)}}^{R_a^{(3)} \rightarrow R_a^{(1)}, R_a^{(2)}; \mu_a} \prod_{p=1}^3 B_{k_a^{(p)} \rightarrow \cup_{b,\alpha} q_{ab,\alpha}^{(p)} \cup_{\beta} l_{a,\beta}^{(p)}}^{R_a^{(p)} \rightarrow \cup_{b,\alpha} r_{ab,\alpha}^{(p)} \cup_{\beta} r_{a,\beta}^{(p)}; \nu_a^{-(p)}}
 \end{aligned} \tag{A.3.43}$$

We see here the manifestation of the last selection rule, enforced by the branching coefficients

$B_{l_{ab,\alpha}^{(3)} \rightarrow l_{ab,\alpha}^{(1)}, l_{ab,\alpha}^{(2)}}^{r_{ab,\alpha}^{(3)} \rightarrow r_{ab,\alpha}^{(1)}, r_{ab,\alpha}^{(2)}; \nu_{ab,\alpha}}$. These quantities are non zero only if the restriction of the $S_{n_{ab,\alpha}^{(1)} + n_{ab,\alpha}^{(2)}}$

representation $r_{ab,\alpha}^{(3)}$ to $S_{n_{ab,\alpha}^{(1)}} \times S_{n_{ab,\alpha}^{(2)}}$ contains the representation $r_{ab,\alpha}^{(1)} \otimes r_{ab,\alpha}^{(2)}$.

With the identity (A.3.43) we have achieved a factorisation of the branching coefficients over all the nodes of the quiver. Moreover, the positive and negative node of every split-node a are now disentangled. There are no symmetric group states $q_{ab,\alpha}^{(i)}$ ($i = 1, 2, 3$), associated with the negative node of the split-node a , that mix with symmetric group states $l_{ab,\alpha}^{(i)}$ ($i = 1, 2, 3$), associated with its positive node.

Plugging eq. (A.3.43) into (A.3.30), we get

$$\begin{aligned}
 G_{\mathbf{L}^{(1)}, \mathbf{L}^{(2)}, \mathbf{L}^{(3)}} &= c_{\mathbf{L}^{(1)}} c_{\mathbf{L}^{(2)}} c_{\mathbf{L}^{(3)}} \prod_a \frac{n_a^{(1)}! n_a^{(2)}!}{d(R_a^{(1)}) d(R_a^{(2)})} \frac{1}{\prod_{b,\alpha} d(r_{ab,\alpha}^{(1)}) d(r_{ab,\alpha}^{(2)})} \sum_{\mu_a} \\
 &\times \left(D_{k_a^{(3)}, t_a^{(3)}}^{R_a^{(3)}} (\lambda_{a-}) B_{t_a^{(3)} \rightarrow k_a^{(1)}, k_a^{(2)}}^{R_a^{(3)} \rightarrow R_a^{(1)}, R_a^{(2)}; \mu_a} \prod_{p=1}^3 B_{k_a^{(p)} \rightarrow \cup_{b,\alpha} r_{ab,\alpha}^{(p)} \cup_{\beta} r_{a,\beta}^{(p)}; \nu_a^{-(p)}}^{R_a^{(p)} \rightarrow \cup_{b,\alpha} r_{ab,\alpha}^{(p)} \cup_{\beta} r_{a,\beta}^{(p)}; \nu_a^{-(p)}} \right) \\
 &\times \left(D_{i_a^{(3)}, h_a^{(3)}}^{R_a^{(3)}} (\lambda_{a+}^{-1}) B_{h_a^{(3)} \rightarrow i_a^{(1)}, i_a^{(2)}}^{R_a^{(3)} \rightarrow R_a^{(1)}, R_a^{(2)}; \mu_a} \prod_{p=1}^3 B_{i_a^{(p)} \rightarrow \cup_{b,\alpha} \bar{r}_{ba,\alpha}^{(p)} \cup_{\gamma} \bar{r}_{a,\gamma}^{(p)}; \nu_a^{+(p)}}^{R_a^{(p)} \rightarrow \cup_{b,\alpha} \bar{r}_{ba,\alpha}^{(p)} \cup_{\gamma} \bar{r}_{a,\gamma}^{(p)}; \nu_a^{+(p)}} \right) \\
 &\times \left(\prod_{b,\alpha} \sum_{\nu_{ab,\alpha}} B_{l_{ab,\alpha}^{(3)} \rightarrow l_{ab,\alpha}^{(1)}, l_{ab,\alpha}^{(2)}}^{r_{ab,\alpha}^{(3)} \rightarrow r_{ab,\alpha}^{(1)}, r_{ab,\alpha}^{(2)}; \nu_{ab,\alpha}} B_{q_{ab,\alpha}^{(3)} \rightarrow q_{ab,\alpha}^{(1)}, q_{ab,\alpha}^{(2)}}^{r_{ab,\alpha}^{(3)} \rightarrow r_{ab,\alpha}^{(1)}, r_{ab,\alpha}^{(2)}; \nu_{ab,\alpha}} \right) \\
 &\times \left(\prod_{\beta} \sum_{\nu_{a,\beta}} B_{l_{a,\beta}^{(3)} \rightarrow l_{a,\beta}^{(1)}, l_{a,\beta}^{(2)}}^{r_{a,\beta}^{(3)} \rightarrow r_{a,\beta}^{(1)}, r_{a,\beta}^{(2)}; \nu_{a,\beta}} C_{S_{a,\beta}^{(3)} \rightarrow S_{a,\beta}^{(1)}, S_{a,\beta}^{(2)}}^{r_{a,\beta}^{(3)}; \nu_{a,\beta} \rightarrow r_{a,\beta}^{(1)}, r_{a,\beta}^{(2)}} \right) \\
 &\times \left(\prod_{\gamma} \sum_{\bar{\nu}_{a,\gamma}} B_{\bar{l}_{a,\gamma}^{(3)} \rightarrow \bar{l}_{a,\gamma}^{(1)}, \bar{l}_{a,\gamma}^{(2)}}^{\bar{r}_{a,\gamma}^{(3)} \rightarrow \bar{r}_{a,\gamma}^{(1)}, \bar{r}_{a,\gamma}^{(2)}; \bar{\nu}_{a,\gamma}} C_{\bar{S}_{a,\gamma}^{(3)} \rightarrow \bar{S}_{a,\gamma}^{(1)}, \bar{S}_{a,\gamma}^{(2)}}^{\bar{r}_{a,\gamma}^{(3)}; \bar{\nu}_{a,\gamma} \rightarrow \bar{r}_{a,\gamma}^{(1)}, \bar{r}_{a,\gamma}^{(2)}} \right) \tag{A.3.44}
 \end{aligned}$$

The latter equation can be finally rewritten as

$$\begin{aligned}
 G_{\mathbf{L}^{(1)}, \mathbf{L}^{(2)}, \mathbf{L}^{(3)}} &= c_{\mathbf{L}^{(1)}} c_{\mathbf{L}^{(2)}} c_{\mathbf{L}^{(3)}} \prod_a \frac{n_a^{(1)}! n_a^{(2)}!}{d(R_a^{(1)}) d(R_a^{(2)})} \frac{1}{\prod_{b,\alpha} d(r_{ab,\alpha}^{(1)}) d(r_{ab,\alpha}^{(2)})} \sum_{\mu_a} \left(\prod_{b,\alpha} \sum_{\nu_{ab,\alpha}} \right) \\
 &\times \left[D_{k_a^{(3)}, t_a^{(3)}}^{R_a^{(3)}} (\lambda_{a-}) B_{t_a^{(3)} \rightarrow k_a^{(1)}, k_a^{(2)}}^{R_a^{(3)} \rightarrow R_a^{(1)}, R_a^{(2)}; \mu_a} \left(\prod_{p=1}^3 B_{k_a^{(p)} \rightarrow \cup_{b,\alpha} r_{ab,\alpha}^{(p)} \cup_{\beta} r_{a,\beta}^{(p)}; \nu_a^{-(p)}}^{R_a^{(p)} \rightarrow \cup_{b,\alpha} r_{ab,\alpha}^{(p)} \cup_{\beta} r_{a,\beta}^{(p)}; \nu_a^{-(p)}} \right) \right. \\
 &\times \left. \left(\prod_{b,\alpha} \sum_{q_{ab,\alpha}} B_{q_{ab,\alpha}^{(3)} \rightarrow q_{ab,\alpha}^{(1)}, q_{ab,\alpha}^{(2)}}^{r_{ab,\alpha}^{(3)} \rightarrow r_{ab,\alpha}^{(1)}, r_{ab,\alpha}^{(2)}; \nu_{ab,\alpha}} \right) \left(\prod_{\beta} \sum_{\nu_{a,\beta}} B_{l_{a,\beta}^{(3)} \rightarrow l_{a,\beta}^{(1)}, l_{a,\beta}^{(2)}}^{r_{a,\beta}^{(3)} \rightarrow r_{a,\beta}^{(1)}, r_{a,\beta}^{(2)}; \nu_{a,\beta}} C_{S_{a,\beta}^{(3)} \rightarrow S_{a,\beta}^{(1)}, S_{a,\beta}^{(2)}}^{r_{a,\beta}^{(3)}; \nu_{a,\beta} \rightarrow r_{a,\beta}^{(1)}, r_{a,\beta}^{(2)}} \right) \right] \\
 &\times \left[D_{i_a^{(3)}, h_a^{(3)}}^{R_a^{(3)}} (\lambda_{a+}^{-1}) B_{h_a^{(3)} \rightarrow i_a^{(1)}, i_a^{(2)}}^{R_a^{(3)} \rightarrow R_a^{(1)}, R_a^{(2)}; \mu_a} \left(\prod_{p=1}^3 B_{i_a^{(p)} \rightarrow \cup_{b,\alpha} \bar{r}_{ba,\alpha}^{(p)} \cup_{\gamma} \bar{r}_{a,\gamma}^{(p)}; \nu_a^{+(p)}}^{R_a^{(p)} \rightarrow \cup_{b,\alpha} \bar{r}_{ba,\alpha}^{(p)} \cup_{\gamma} \bar{r}_{a,\gamma}^{(p)}; \nu_a^{+(p)}} \right) \right. \\
 &\times \left. \left(\prod_{b,\alpha} \sum_{l_{ba,\alpha}} B_{l_{ba,\alpha}^{(3)} \rightarrow l_{ba,\alpha}^{(1)}, l_{ba,\alpha}^{(2)}}^{\bar{r}_{ba,\alpha}^{(3)} \rightarrow \bar{r}_{ba,\alpha}^{(1)}, \bar{r}_{ba,\alpha}^{(2)}; \nu_{ba,\alpha}} \right) \left(\prod_{\gamma} \sum_{\bar{\nu}_{a,\gamma}} B_{\bar{l}_{a,\gamma}^{(3)} \rightarrow \bar{l}_{a,\gamma}^{(1)}, \bar{l}_{a,\gamma}^{(2)}}^{\bar{r}_{a,\gamma}^{(3)} \rightarrow \bar{r}_{a,\gamma}^{(1)}, \bar{r}_{a,\gamma}^{(2)}; \bar{\nu}_{a,\gamma}} C_{\bar{S}_{a,\gamma}^{(3)} \rightarrow \bar{S}_{a,\gamma}^{(1)}, \bar{S}_{a,\gamma}^{(2)}}^{\bar{r}_{a,\gamma}^{(3)}; \bar{\nu}_{a,\gamma} \rightarrow \bar{r}_{a,\gamma}^{(1)}, \bar{r}_{a,\gamma}^{(2)}} \right) \right] \tag{A.3.45}
 \end{aligned}$$

The last equation shows that, at each node a in the quiver, the holomorphic GIO ring structure constant factorises into two components, one associated with the positive node and one asso-

ciated with the negative node of the corresponding split node a . Figure 34 shows a pictorial interpretation of this formula.

A.4 Quiver restricted Schur polynomials for an $\mathcal{N} = 2$ SQCD: $\vec{n} = (2, 2, 2)$ field content

In this appendix we will summarise the main steps which led to the expression of the operators in (3.5.43). In particular we will derive all the fourteen different quiver characters, corresponding to the set of labels \mathbf{L}_i described in (3.5.36), $i = 1, 2, \dots, 14$. The operators (3.5.43) are then readily obtained by using the definition (3.2.19).

We start from $\mathcal{O}(\mathbf{L}_1)$ and $\mathcal{O}(\mathbf{L}_2)$. Their quiver characters can be immediately computed to be respectively

$$\chi(\mathbf{L}_1, \vec{s}, \sigma) = \frac{1}{\sqrt{4!}} C_{s_1, s_2}^{\overline{ij}} C_{\bar{s}_1, \bar{s}_2}^{\overline{pq}}, \quad \chi(\mathbf{L}_2, \vec{s}, \sigma) = \frac{1}{\sqrt{4!}} \text{sign}(\sigma) C_{s_1, s_2}^{\overline{ij}} C_{\bar{s}_1, \bar{s}_2}^{\overline{pq}} \quad (\text{A.4.1})$$

Here we used the Clebsch-Gordan coefficients already derived in (3.5.29). We will keep using this notation for the rest of this appendix.

Let us now turn to the three dimensional representation $\begin{smallmatrix} \square & \square & \square \end{smallmatrix}$ of S_4 . We choose a basis $\{e_1, e_2, e_3\}$ in which the three Jucys-Murphy elements (12), (13) + (23), (14) + (24) + (34) of S_4 have the eigenvalues in table 3.

	(12)	(13) + (23)	(14) + (24) + (34)
e_1	1	-1	2
e_2	-1	1	2
e_3	1	2	-1

Table 3: Eigenvalues of the Jucys-Murphy elements (12), (13) + (23), (14) + (24) + (34) on our chosen basis $\{e_1, e_2, e_3\}$ for the standard representation of S_4 .

Alternatively, we can specify our basis choice with the standard Young tableaux

$$e_1 \sim \begin{smallmatrix} \square & \square & \square \\ \square \end{smallmatrix}, \quad e_2 \sim \begin{smallmatrix} \square & \square & \square \\ \square \end{smallmatrix}, \quad e_3 \sim \begin{smallmatrix} \square & \square & \square \\ \square \end{smallmatrix} \quad (\text{A.4.2})$$

We now consider the group restriction $S_4|_{S_2 \times S_2} = \{(1), (12), (34), (12)(34)\}$. Under this restriction, the $\begin{smallmatrix} \square & \square & \square \\ \square \end{smallmatrix}$ decomposes as

$$\begin{smallmatrix} \square & \square & \square \\ \square \end{smallmatrix} \Big|_{S_2 \times S_2} = \begin{smallmatrix} \square & \square \\ \square \end{smallmatrix} \otimes \begin{smallmatrix} \square & \square \\ \square \end{smallmatrix} \oplus \begin{smallmatrix} \square \\ \square \end{smallmatrix} \otimes \begin{smallmatrix} \square & \square \\ \square \end{smallmatrix} \oplus \begin{smallmatrix} \square & \square \\ \square \end{smallmatrix} \otimes \begin{smallmatrix} \square \\ \square \end{smallmatrix} \quad (\text{A.4.3})$$

The branching coefficients for this group reduction will then be the matrix elements of the

orthogonal operator B such that

$$\begin{aligned}
 B^{-1}D^{\square\square}((1))B &= \begin{pmatrix} 1 & 0 & 0 \\ 0 & 1 & 0 \\ 0 & 0 & 1 \end{pmatrix}, & B^{-1}D^{\square\square}((12))B &= \begin{pmatrix} 1 & 0 & 0 \\ 0 & -1 & 0 \\ 0 & 0 & 1 \end{pmatrix}, \\
 B^{-1}D^{\square\square}((34))B &= \begin{pmatrix} 1 & 0 & 0 \\ 0 & 1 & 0 \\ 0 & 0 & -1 \end{pmatrix}, & B^{-1}D^{\square\square}((12)(34))B &= \begin{pmatrix} 1 & 0 & 0 \\ 0 & -1 & 0 \\ 0 & 0 & -1 \end{pmatrix}
 \end{aligned} \tag{A.4.4}$$

In our basis choice (A.4.2) the matrix B reads

$$B = \frac{1}{\sqrt{3}} \begin{pmatrix} \sqrt{2} & 0 & -1 \\ 0 & \sqrt{3} & 0 \\ 1 & 0 & \sqrt{2} \end{pmatrix} \tag{A.4.5}$$

The branching coefficient for (A.4.3) are then

$$\begin{aligned}
 B_{1 \rightarrow 1,1}^{\square\square \rightarrow \square, \square} &= \sqrt{\frac{2}{3}}, & B_{1 \rightarrow 1,1}^{\square\square \rightarrow \square, \square\square} &= 0, & B_{1 \rightarrow 1,1}^{\square\square \rightarrow \square, \square\square} &= -\frac{1}{\sqrt{3}}, \\
 B_{2 \rightarrow 1,1}^{\square\square \rightarrow \square, \square} &= 0, & B_{2 \rightarrow 1,1}^{\square\square \rightarrow \square, \square\square} &= 1, & B_{2 \rightarrow 1,1}^{\square\square \rightarrow \square, \square\square} &= 0, \\
 B_{3 \rightarrow 1,1}^{\square\square \rightarrow \square, \square} &= 1, & B_{3 \rightarrow 1,1}^{\square\square \rightarrow \square, \square\square} &= 0, & B_{3 \rightarrow 1,1}^{\square\square \rightarrow \square, \square\square} &= \sqrt{\frac{2}{3}}
 \end{aligned} \tag{A.4.6}$$

We now define the orthogonal projectors

$$\begin{aligned}
 P_{i,j}^{\square\square \rightarrow \square, \square} &= B_{i \rightarrow 1,1}^{\square\square \rightarrow \square, \square} B_{j \rightarrow 1,1}^{\square\square \rightarrow \square, \square}, & P_{i,j}^{\square\square \rightarrow \square, \square\square} &= B_{i \rightarrow 1,1}^{\square\square \rightarrow \square, \square\square} B_{j \rightarrow 1,1}^{\square\square \rightarrow \square, \square\square}, \\
 P_{i,j}^{\square\square \rightarrow \square, \square\square} &= B_{i \rightarrow 1,1}^{\square\square \rightarrow \square, \square\square} B_{j \rightarrow 1,1}^{\square\square \rightarrow \square, \square\square}
 \end{aligned} \tag{A.4.7}$$

which project the $\square\square\square$ of S_4 on the $\square\square \otimes \square\square$, on the $\square \otimes \square\square$ and on the $\square\square \otimes \square$ of $S_2 \times S_2$ respectively. We also define a fourth operator, that we label T , as

$$T_{i,j} = B_{i \rightarrow 1,1}^{\square\square \rightarrow \square, \square} B_{j \rightarrow 1,1}^{\square\square \rightarrow \square, \square} \tag{A.4.8}$$

These matrices explicitly read

$$\begin{aligned}
 P^{\square\square \rightarrow \square, \square} &= \frac{1}{3} \begin{pmatrix} 2 & 0 & \sqrt{2} \\ 0 & 0 & 0 \\ \sqrt{2} & 0 & 1 \end{pmatrix}, & P^{\square\square \rightarrow \square, \square} &= \begin{pmatrix} 0 & 0 & 0 \\ 0 & 1 & 0 \\ 0 & 0 & 0 \end{pmatrix}, \\
 P^{\square\square \rightarrow \square, \square} &= \frac{1}{3} \begin{pmatrix} 1 & 0 & -\sqrt{2} \\ 0 & 0 & 0 \\ -\sqrt{2} & 0 & 2 \end{pmatrix}, & T &= \frac{1}{3} \begin{pmatrix} -\sqrt{2} & 0 & 2 \\ 0 & 0 & 0 \\ -1 & 0 & \sqrt{2} \end{pmatrix}
 \end{aligned} \tag{A.4.9}$$

The quiver character for $\mathcal{O}(\mathbf{L}_3)$, $\mathcal{O}(\mathbf{L}_4)$, $\mathcal{O}(\mathbf{L}_5)$, $\mathcal{O}(\mathbf{L}_6)$, $\mathcal{O}(\mathbf{L}_7)$ are then

$$\begin{aligned}
 \chi(\mathbf{L}_3, \vec{s}, \sigma) &= \frac{1}{2\sqrt{2}} \text{Tr} [D^{\square\square}(\sigma) P^{\square\square \rightarrow \square, \square}] C_{s_1, s_2}^{\begin{smallmatrix} i & j \\ \hline \end{smallmatrix}} C_{\bar{s}_1, \bar{s}_2}^{\begin{smallmatrix} \bar{p} & \bar{q} \\ \hline \end{smallmatrix}}, \\
 \chi(\mathbf{L}_4, \vec{s}, \sigma) &= \frac{1}{2\sqrt{2}} \text{Tr} [D^{\square\square}(\sigma) P^{\square\square \rightarrow \square, \square}] C_{s_1, s_2}^{\begin{smallmatrix} i & j \\ \hline \end{smallmatrix}} C_{\bar{s}_1, \bar{s}_2}^{\begin{smallmatrix} \bar{p} & \bar{q} \\ \hline \end{smallmatrix}}, \\
 \chi(\mathbf{L}_5, \vec{s}, \sigma) &= \frac{1}{2\sqrt{2}} \text{Tr} [D^{\square\square}(\sigma) P^{\square\square \rightarrow \square, \square}] C_{s_1, s_2}^{\begin{smallmatrix} i \\ \hline j \end{smallmatrix}} C_{\bar{s}_1, \bar{s}_2}^{\begin{smallmatrix} \bar{p} \\ \hline \bar{q} \end{smallmatrix}}, \\
 \chi(\mathbf{L}_6, \vec{s}, \sigma) &= \frac{1}{2\sqrt{2}} \text{Tr} [D^{\square\square}(\sigma) T] C_{s_1, s_2}^{\begin{smallmatrix} i & j \\ \hline \end{smallmatrix}} C_{\bar{s}_1, \bar{s}_2}^{\begin{smallmatrix} \bar{p} \\ \hline \bar{q} \end{smallmatrix}}, \\
 \chi(\mathbf{L}_7, \vec{s}, \sigma) &= \frac{1}{2\sqrt{2}} \text{Tr} [D^{\square\square}(\sigma) T^t] C_{s_1, s_2}^{\begin{smallmatrix} i \\ \hline j \end{smallmatrix}} C_{\bar{s}_1, \bar{s}_2}^{\begin{smallmatrix} \bar{p} & \bar{q} \\ \hline \end{smallmatrix}}
 \end{aligned} \tag{A.4.10}$$

Here T^t is the transpose of the matrix T in (A.4.8).

We now focus on the $\begin{smallmatrix} \square & \square \\ \hline \square \end{smallmatrix}$ representation of S_4 . This representation can be obtained by tensoring together the standard and the sign representation of S_4 :

$$\begin{smallmatrix} \square & \square \\ \hline \square \end{smallmatrix} = \begin{smallmatrix} \square & \square & \square \\ \hline \square \end{smallmatrix} \otimes \begin{smallmatrix} \square \\ \hline \square \\ \hline \square \end{smallmatrix} \tag{A.4.11}$$

In the following, we will continue to use (A.4.2) as our basis choice for the standard representation $\begin{smallmatrix} \square & \square \\ \hline \square \end{smallmatrix}$. Under the group restriction $S_4|_{S_2 \times S_2} = \{(1), (12), (34), (12)(34)\}$, the $\begin{smallmatrix} \square & \square \\ \hline \square \end{smallmatrix}$ decomposes as

$$\begin{smallmatrix} \square & \square \\ \hline \square \end{smallmatrix} \Big|_{S_2 \times S_2} = \begin{smallmatrix} \square & \square \\ \hline \square \end{smallmatrix} \otimes \begin{smallmatrix} \square \\ \hline \square \end{smallmatrix} \oplus \begin{smallmatrix} \square \\ \hline \square \end{smallmatrix} \otimes \begin{smallmatrix} \square & \square \\ \hline \square \end{smallmatrix} \oplus \begin{smallmatrix} \square \\ \hline \square \end{smallmatrix} \otimes \begin{smallmatrix} \square \\ \hline \square \end{smallmatrix} \tag{A.4.12}$$

As in the previous instance, the branching coefficients for this group reduction are the matrix

elements of the orthogonal operator B , such that

$$\begin{aligned}
 B^{-1}D^{\boxplus}((1))B &= \begin{pmatrix} 1 & 0 & 0 \\ 0 & 1 & 0 \\ 0 & 0 & 1 \end{pmatrix}, & B^{-1}D^{\boxplus}((12))B &= \begin{pmatrix} 1 & 0 & 0 \\ 0 & -1 & 0 \\ 0 & 0 & -1 \end{pmatrix}, \\
 B^{-1}D^{\boxplus}((34))B &= \begin{pmatrix} -1 & 0 & 0 \\ 0 & 1 & 0 \\ 0 & 0 & -1 \end{pmatrix}, & B^{-1}D^{\boxplus}((12)(34))B &= \begin{pmatrix} -1 & 0 & 0 \\ 0 & -1 & 0 \\ 0 & 0 & 1 \end{pmatrix}
 \end{aligned} \tag{A.4.13}$$

In our basis choice, the matrix B reads

$$B = \frac{1}{\sqrt{3}} \begin{pmatrix} 0 & -1 & \sqrt{2} \\ \sqrt{3} & 0 & 0 \\ 0 & \sqrt{2} & 1 \end{pmatrix} \tag{A.4.14}$$

The branching coefficient for (A.4.12) are thus

$$\begin{aligned}
 B_{1 \rightarrow 1,1}^{\boxplus \rightarrow \square, \boxplus} &= 0, & B_{1 \rightarrow 1,1}^{\boxplus \rightarrow \boxplus, \square} &= -\frac{1}{\sqrt{3}}, & B_{1 \rightarrow 1,1}^{\boxplus \rightarrow \boxplus, \boxplus} &= \sqrt{\frac{2}{3}}, \\
 B_{2 \rightarrow 1,1}^{\boxplus \rightarrow \square, \boxplus} &= 1, & B_{2 \rightarrow 1,1}^{\boxplus \rightarrow \boxplus, \square} &= 0, & B_{2 \rightarrow 1,1}^{\boxplus \rightarrow \boxplus, \boxplus} &= 0, \\
 B_{3 \rightarrow 1,1}^{\boxplus \rightarrow \square, \boxplus} &= 0, & B_{3 \rightarrow 1,1}^{\boxplus \rightarrow \boxplus, \square} &= \sqrt{\frac{2}{3}}, & B_{3 \rightarrow 1,1}^{\boxplus \rightarrow \boxplus, \boxplus} &= \frac{1}{\sqrt{3}}
 \end{aligned} \tag{A.4.15}$$

Closely following the procedure of the previous paragraph, we define the orthogonal projectors

$$\begin{aligned}
 P_{i,j}^{\boxplus \rightarrow \square, \boxplus} &= B_{i \rightarrow 1,1}^{\boxplus \rightarrow \square, \boxplus} B_{j \rightarrow 1,1}^{\boxplus \rightarrow \square, \boxplus}, & P_{i,j}^{\boxplus \rightarrow \boxplus, \square} &= B_{i \rightarrow 1,1}^{\boxplus \rightarrow \boxplus, \square} B_{j \rightarrow 1,1}^{\boxplus \rightarrow \boxplus, \square}, \\
 P_{i,j}^{\boxplus \rightarrow \boxplus, \boxplus} &= B_{i \rightarrow 1,1}^{\boxplus \rightarrow \boxplus, \boxplus} B_{j \rightarrow 1,1}^{\boxplus \rightarrow \boxplus, \boxplus}
 \end{aligned} \tag{A.4.16}$$

These operators project the \boxplus of S_4 on the $\square \otimes \square$, on the $\boxplus \otimes \square$ and on the $\boxplus \otimes \boxplus$ of $S_2 \times S_2$ respectively. We also introduce the operator V :

$$V_{i,j} = B_{i \rightarrow 1,1}^{\boxplus \rightarrow \boxplus, \square} B_{j \rightarrow 1,1}^{\boxplus \rightarrow \boxplus, \boxplus} \tag{A.4.17}$$

These matrices explicitly read

$$\begin{aligned}
 P^{\boxplus \rightarrow \boxtimes, \boxplus} &= \begin{pmatrix} 0 & 0 & 0 \\ 0 & 1 & 0 \\ 0 & 0 & 0 \end{pmatrix}, & P^{\boxplus \rightarrow \boxplus, \boxtimes} &= \frac{1}{3} \begin{pmatrix} 1 & 0 & -\sqrt{2} \\ 0 & 0 & 0 \\ -\sqrt{2} & 0 & 2 \end{pmatrix}, \\
 P^{\boxplus \rightarrow \boxplus, \boxplus} &= \frac{1}{3} \begin{pmatrix} 2 & 0 & \sqrt{2} \\ 0 & 0 & 0 \\ -\sqrt{2} & 0 & 1 \end{pmatrix}, & V &= \frac{1}{3} \begin{pmatrix} -\sqrt{2} & 0 & -1 \\ 0 & 0 & 0 \\ 2 & 0 & \sqrt{2} \end{pmatrix}
 \end{aligned} \tag{A.4.18}$$

Notice that $V = T^t$, where T is the matrix defined in (A.4.9). The quiver character for $\mathcal{O}(\mathbf{L}_8)$, $\mathcal{O}(\mathbf{L}_9)$, $\mathcal{O}(\mathbf{L}_{10})$, $\mathcal{O}(\mathbf{L}_{11})$, $\mathcal{O}(\mathbf{L}_{12})$ are therefore

$$\begin{aligned}
 \chi(\mathbf{L}_8, \vec{s}, \sigma) &= \frac{1}{2\sqrt{2}} \operatorname{Tr} \left[D^{\boxplus}(\sigma) P^{\boxplus \rightarrow \boxtimes, \boxplus} \right] C_{s_1, s_2}^{\begin{smallmatrix} i \\ j \end{smallmatrix}} C_{\vec{s}_1, \vec{s}_2}^{\begin{smallmatrix} p \\ q \end{smallmatrix}}, \\
 \chi(\mathbf{L}_9, \vec{s}, \sigma) &= \frac{1}{2\sqrt{2}} \operatorname{Tr} \left[D^{\boxplus}(\sigma) P^{\boxplus \rightarrow \boxplus, \boxtimes} \right] C_{s_1, s_2}^{\begin{smallmatrix} i & j \\ & \end{smallmatrix}} C_{\vec{s}_1, \vec{s}_2}^{\begin{smallmatrix} p & q \\ & \end{smallmatrix}}, \\
 \chi(\mathbf{L}_{10}, \vec{s}, \sigma) &= \frac{1}{2\sqrt{2}} \operatorname{Tr} \left[D^{\boxplus}(\sigma) P^{\boxplus \rightarrow \boxplus, \boxplus} \right] C_{s_1, s_2}^{\begin{smallmatrix} i \\ j \end{smallmatrix}} C_{\vec{s}_1, \vec{s}_2}^{\begin{smallmatrix} p \\ q \end{smallmatrix}}, \\
 \chi(\mathbf{L}_{11}, \vec{s}, \sigma) &= \frac{1}{2\sqrt{2}} \operatorname{Tr} \left[D^{\boxplus}(\sigma) V \right] C_{s_1, s_2}^{\begin{smallmatrix} i & j \\ & \end{smallmatrix}} C_{\vec{s}_1, \vec{s}_2}^{\begin{smallmatrix} p \\ q \end{smallmatrix}}, \\
 \chi(\mathbf{L}_{12}, \vec{s}, \sigma) &= \frac{1}{2\sqrt{2}} \operatorname{Tr} \left[D^{\boxplus}(\sigma) V^t \right] C_{s_1, s_2}^{\begin{smallmatrix} i \\ j \end{smallmatrix}} C_{\vec{s}_1, \vec{s}_2}^{\begin{smallmatrix} p & q \\ & \end{smallmatrix}}
 \end{aligned} \tag{A.4.19}$$

Two operators still remain. They can be obtained by considering the S_4 $\begin{smallmatrix} \square & \square \\ \square & \square \end{smallmatrix}$ representation branching

$$\begin{smallmatrix} \square & \square \\ \square & \square \end{smallmatrix} \Big|_{S_2 \times S_2} = \begin{smallmatrix} \square & \square \\ \square & \square \end{smallmatrix} \otimes \begin{smallmatrix} \square & \square \\ \square & \square \end{smallmatrix} \oplus \begin{smallmatrix} \square \\ \square \end{smallmatrix} \otimes \begin{smallmatrix} \square \\ \square \end{smallmatrix} \tag{A.4.20}$$

The $\begin{smallmatrix} \square & \square \\ \square & \square \end{smallmatrix}$ representation of S_4 is really a representation of the quotient group $S_4/\{(1), (12)(34), (13)(24), (14)(23)\}$, which in turn is isomorphic to S_3 . This representation is thus just the standard representation of S_3 pulled back to S_4 via this quotient [68]. We choose a basis $\{e_1, e_2\}$ in which the Jucys-Murphy elements (12), (13) + (23), (14) + (24) + (34) of S_4 have the eigenvalues in table 4.

	(12)	(13) + (23)	(14) + (24) + (34)
e_1	1	-1	0
e_2	-1	1	0

Table 4: Eigenvalues of the Jucys-Murphy elements (12), (13) + (23), (14) + (24) + (34) on our chosen basis $\{e_1, e_2\}$ for the two-dimensional representation of S_4 .

The standard Young tableaux labelling of this basis is

$$e_1 \sim \begin{array}{|c|c|} \hline 1 & 2 \\ \hline 3 & 4 \\ \hline \end{array}, \quad e_2 \sim \begin{array}{|c|c|} \hline 1 & 3 \\ \hline 2 & 4 \\ \hline \end{array} \quad (\text{A.4.21})$$

An explicit representation of $\begin{array}{|c|c|} \hline \square & \square \\ \hline \end{array}$ is therefore obtained by considering the set of matrices

$$\begin{aligned} D^{\square}((1)) &= D^{\square}((12)(34)) = D^{\square}((13)(24)) = D^{\square}((14)(23)) = \begin{pmatrix} 1 & 0 \\ 0 & 1 \end{pmatrix}, \\ D^{\square}((12)) &= D^{\square}((34)) = D^{\square}((1324)) = D^{\square}((1423)) = \begin{pmatrix} 1 & 0 \\ 0 & -1 \end{pmatrix}, \\ D^{\square}((13)) &= D^{\square}((24)) = D^{\square}((1234)) = D^{\square}((1432)) = \begin{pmatrix} -\frac{1}{2} & -\frac{\sqrt{3}}{2} \\ -\frac{\sqrt{3}}{2} & \frac{1}{2} \end{pmatrix}, \\ D^{\square}((23)) &= D^{\square}((14)) = D^{\square}((1342)) = D^{\square}((1243)) = \begin{pmatrix} -\frac{1}{2} & \frac{\sqrt{3}}{2} \\ \frac{\sqrt{3}}{2} & \frac{1}{2} \end{pmatrix}, \\ D^{\square}((123)) &= D^{\square}((243)) = D^{\square}((142)) = D^{\square}((134)) = \begin{pmatrix} -\frac{1}{2} & -\frac{\sqrt{3}}{2} \\ \frac{\sqrt{3}}{2} & -\frac{1}{2} \end{pmatrix}, \\ D^{\square}((132)) &= D^{\square}((143)) = D^{\square}((234)) = D^{\square}((124)) = \begin{pmatrix} -\frac{1}{2} & \frac{\sqrt{3}}{2} \\ -\frac{\sqrt{3}}{2} & -\frac{1}{2} \end{pmatrix}, \end{aligned} \quad (\text{A.4.22})$$

With this basis choice, under the group restriction $S_4|_{S_2 \times S_2} = \{(1), (12), (34), (12)(34)\}$, we have

$$D^{\square}((1)) = \begin{pmatrix} 1 & 0 \\ 0 & 1 \end{pmatrix}, \quad D^{\square}((12)) = \begin{pmatrix} 1 & 0 \\ 0 & -1 \end{pmatrix}, \quad (\text{A.4.23})$$

$$D^{\square}((34)) = \begin{pmatrix} 1 & 0 \\ 0 & -1 \end{pmatrix}, \quad D^{\square}((12)(34)) = \begin{pmatrix} 1 & 0 \\ 0 & 1 \end{pmatrix}$$

The decomposition (A.4.20) is already manifest. The branching coefficients for this reduction are then

$$B_{j \rightarrow 1,1}^{\square \rightarrow \square, \square} = \delta_{j,1}, \quad B_{j \rightarrow 1,1}^{\square \rightarrow \square, \square} = \delta_{j,2}, \quad j = 1, 2 \quad (\text{A.4.24})$$

We can now write the orthogonal projectors

$$\begin{aligned}
 P_{i,j}^{\boxplus \rightarrow \square, \square} &= B_{i \rightarrow 1,1}^{\boxplus \rightarrow \square, \square} B_{j \rightarrow 1,1}^{\boxplus \rightarrow \square, \square} \longrightarrow P^{\boxplus \rightarrow \square, \square} = \begin{pmatrix} 1 & 0 \\ 0 & 0 \end{pmatrix}, \\
 P_{i,j}^{\boxplus \rightarrow \boxplus, \boxplus} &= B_{i \rightarrow 1,1}^{\boxplus \rightarrow \boxplus, \boxplus} B_{j \rightarrow 1,1}^{\boxplus \rightarrow \boxplus, \boxplus} \longrightarrow P^{\boxplus \rightarrow \boxplus, \boxplus} = \begin{pmatrix} 0 & 0 \\ 0 & 1 \end{pmatrix}
 \end{aligned} \tag{A.4.25}$$

projecting the \boxplus of S_4 on the $\square \otimes \square$ and on the $\boxplus \otimes \boxplus$ of $S_2 \times S_2$ respectively. The quiver characters for the remaining two operators, $\mathcal{O}(\mathbf{L}_{13})$ and $\mathcal{O}(\mathbf{L}_{14})$, are then

$$\begin{aligned}
 \chi(\mathbf{L}_{13}, \vec{s}, \sigma) &= \frac{1}{2\sqrt{3}} \text{Tr} [D^{\boxplus}(\sigma) P^{\boxplus \rightarrow \square, \square}] C_{s_1, s_2}^{\begin{smallmatrix} i & j \\ \square & \square \end{smallmatrix}} C_{\vec{s}_1, \vec{s}_2}^{\begin{smallmatrix} \bar{p} & \bar{q} \\ \square & \square \end{smallmatrix}}, \\
 \chi(\mathbf{L}_{14}, \vec{s}, \sigma) &= \frac{1}{2\sqrt{3}} \text{Tr} [D^{\boxplus}(\sigma) P^{\boxplus \rightarrow \boxplus, \boxplus}] C_{s_1, s_2}^{\begin{smallmatrix} i & j \\ \boxplus & \boxplus \end{smallmatrix}} C_{\vec{s}_1, \vec{s}_2}^{\begin{smallmatrix} \bar{p} & \bar{q} \\ \boxplus & \boxplus \end{smallmatrix}}
 \end{aligned} \tag{A.4.26}$$

Appendix B

Proofs and Derivation of the Counting Formulae

B.1 Generating function

B.1.1 Derivation of the generating function

In this appendix we will derive eq. (2.2.25). Our starting point will be eq. (2.2.14):

$$\mathcal{Z}(\{x_{ab,\alpha}\}, \{\mathcal{T}_{a,\beta}\}, \{\bar{\mathcal{T}}_{a,\gamma}\}) = \sum_{\{n_{ab,\alpha}\}} \sum_{\substack{\{n_{a,\beta}\} \\ \{\bar{n}_{a,\gamma}\}}} \left(\prod_{a,b,\alpha} x_{ab,\alpha}^{n_{ab,\alpha}} \right) \sum_{\substack{R_a \vdash n_a \\ l(R_a) \leq N_a}} \sum_{\{r_{ab,\alpha} \vdash n_{ab,\alpha}\}} \sum_{\substack{\{r_{a,\beta} \vdash n_{a,\beta}\} \\ \{\bar{r}_{a,\gamma} \vdash \bar{n}_{a,\gamma}\}}} \quad (\text{B.1.1})$$

$$\prod_a g(\cup_{b,\alpha} r_{ab,\alpha} \cup_{\beta} r_{a,\beta}; R_a) g(\cup_{b,\alpha} \bar{r}_{ba,\alpha} \cup_{\gamma} \bar{r}_{a,\gamma}; R_a) \left(\prod_{\beta} \chi_{r_{a,\beta}}(\mathcal{T}_{a,\beta}) \right) \left(\prod_{\gamma} \chi_{\bar{r}_{a,\gamma}}(\bar{\mathcal{T}}_{a,\gamma}) \right)$$

in which we will take the large N limit, in such a way that we will be allowed to drop the constraints on the sums over R_a . The derivation will involve well known symmetric group identities. In particular, we will use the equation

$$\chi_R(U) = \sum_{\sigma \in S_n} \frac{\chi_R(\sigma)}{n!} \prod_i (\text{Tr } U^i)^{[\sigma]^{(i)}}, \quad U \in U(F) \quad (\text{B.1.2a})$$

where R is a partition of n , $[\sigma]^{(i)}$ is the number of cycles of length i in the conjugacy class $[\sigma]$ of the permutation $\sigma \in S_n$ and $\text{Tr}(U)$ is the trace taken in the fundamental representation of $U(F)$. We will also use the formulae

$$\sum_{R \vdash n} \chi_R(\sigma) \chi_R(\tau) = \sum_{\gamma \in S_n} \delta(\gamma \sigma \gamma^{-1} \tau^{-1}), \quad (\text{B.1.2b})$$

and

$$g(\cup_a r_a; R) = \left(\prod_a \sum_{\sigma_a} \right) \chi_R(\times_a \sigma_a) \prod_a \frac{\chi_{r_a}(\sigma_a)}{n_a!} \quad (\text{B.1.2c})$$

Here r_a are partitions of n_a and $\delta(\sigma)$ is the symmetric group delta function, which equals one iff σ is the identity permutation. With these relations we can rewrite \mathcal{Z} in (B.1.1) as

$$\begin{aligned} \mathcal{Z} = & \sum_{\vec{n}} \sum_{\vec{\sigma}, \vec{\sigma}'} \prod_a \left(\prod_{b, \alpha} \sum_{r_{ab, \alpha}} \frac{x_{ab, \alpha}^{\sum_i i [\sigma_{ab, \alpha}]^{(i)}}}{(n_{ab, \alpha}!)^2} \chi_{r_{ab, \alpha}}(\sigma_{ab, \alpha}) \chi_{r_{ab, \alpha}}(\sigma'_{ab, \alpha}) \right) \\ & \times \left(\prod_{\beta} \sum_{r_{a, \beta}} \frac{\prod_i (\text{Tr } \mathcal{T}_{a, \beta}^i)^{[\sigma_{a, \beta}]^{(i)}}}{(n_{a, \beta}!)^2} \chi_{r_{a, \beta}}(\sigma_{a, \beta}) \chi_{r_{a, \beta}}(\sigma'_{a, \beta}) \right) \\ & \times \left(\prod_{\gamma} \sum_{r_{a, \gamma}} \frac{\prod_i (\text{Tr } \bar{\mathcal{T}}_{a, \gamma}^i)^{[\bar{\sigma}_{a, \gamma}]^{(i)}}}{(\bar{n}_{a, \gamma}!)^2} \chi_{\bar{r}_{a, \gamma}}(\bar{\sigma}_{a, \gamma}) \chi_{\bar{r}_{a, \gamma}}(\bar{\sigma}'_{a, \gamma}) \right) \\ & \times \sum_{R_a} \chi_{R_a}(\times_{b, \alpha} \sigma_{ab, \alpha} \times_{\beta} \sigma'_{a, \beta}) \chi_{R_a}(\times_{b, \alpha} \sigma'_{ba, \alpha} \times_{\gamma} \bar{\sigma}'_{a, \gamma}) \end{aligned} \quad (\text{B.1.3})$$

where we defined

$$\begin{aligned} \vec{\sigma} &= \cup_{a, b, \alpha} \{\sigma_{ab, \alpha}\} \cup_{a, \beta} \{\sigma_{a, \beta}\} \cup_{a, \gamma} \{\bar{\sigma}_{a, \gamma}\}, \\ \sigma_{ab, \alpha} &\in S_{n_{ab, \alpha}}, \quad \sigma_{a, \beta} \in S_{n_{a, \beta}}, \quad \bar{\sigma}_{a, \gamma} \in S_{\bar{n}_{a, \gamma}} \end{aligned} \quad (\text{B.1.4})$$

and similarly

$$\vec{n} = \cup_{a, b, \alpha} \{n_{ab, \alpha}\} \cup_{a, \beta} \{n_{a, \beta}\} \cup_{a, \gamma} \{\bar{n}_{a, \gamma}\} \quad (\text{B.1.5})$$

Summing over the representations $R_a, r_{ab, \alpha}, r_{a, \beta}, \bar{r}_{a, \gamma}$ then gives, using (B.1.2b)

$$\begin{aligned} \mathcal{Z} = & \sum_{\vec{n}} \sum_{\vec{\sigma}, \vec{\sigma}'} \sum_{\vec{\rho}} \prod_a \left(\prod_{b, \alpha} \frac{x_{ab, \alpha}^{\sum_i i [\sigma_{ab, \alpha}]^{(i)}}}{(n_{ab, \alpha}!)^2} \delta(\rho_{ab, \alpha} \sigma_{ab, \alpha} \rho_{ab, \alpha}^{-1} \sigma'_{ab, \alpha}) \right) \\ & \times \left(\prod_{\beta} \frac{\prod_i (\text{Tr } \mathcal{T}_{a, \beta}^i)^{[\sigma_{a, \beta}]^{(i)}}}{(n_{a, \beta}!)^2} \delta(\rho_{a, \beta} \sigma_{a, \beta} \rho_{a, \beta}^{-1} \sigma'_{a, \beta}) \right) \\ & \times \left(\prod_{\gamma} \frac{\prod_i (\text{Tr } \bar{\mathcal{T}}_{a, \gamma}^i)^{[\bar{\sigma}_{a, \gamma}]^{(i)}}}{(\bar{n}_{a, \gamma}!)^2} \delta(\bar{\rho}_{a, \gamma} \bar{\sigma}_{a, \gamma} \bar{\rho}_{a, \gamma}^{-1} \bar{\sigma}'_{a, \gamma}) \right) \\ & \times \sum_{\Gamma_a} \delta(\Gamma_a (\times_{b, \alpha} \sigma_{ab, \alpha} \times_{\beta} \sigma'_{a, \beta}) \Gamma_a^{-1} (\times_{b, \alpha} \sigma'_{ba, \alpha} \times_{\gamma} \bar{\sigma}'_{a, \gamma})^{-1}) \end{aligned} \quad (\text{B.1.6})$$

with

$$\begin{aligned}\vec{\rho} &= \cup_{a,b,\alpha} \{\rho_{ab,\alpha}\} \cup_{a,\beta} \{\rho_{a,\beta}\} \cup_{a,\gamma} \{\bar{\rho}_{a,\gamma}\}, \\ \rho_{ab,\alpha} &\in \mathcal{S}_{n_{ab,\alpha}}, \quad \rho_{a,\beta} \in \mathcal{S}_{n_{a,\beta}}, \quad \bar{\rho}_{a,\gamma} \in \mathcal{S}_{\bar{n}_{a,\gamma}}\end{aligned}\quad (\text{B.1.7})$$

If we now sum over the $\vec{\sigma}'$ permutations we get, redefining the dummy Γ_a permutations as $\Gamma_a \rightarrow (\times_{b,\alpha} \rho_{ba,\alpha} \times_{\gamma} \bar{\rho}_{a,\gamma})^{-1} \Gamma_a (\times_{b,\alpha} 1 \times_{\beta} \rho_{a,\beta})$:

$$\begin{aligned}\mathcal{Z} &= \sum_{\vec{n}} \sum_{\vec{\sigma}, \vec{\rho}} \prod_a \left(\prod_{b,\alpha} \frac{x_{ab,\alpha}^{\sum_i i [\sigma_{ab,\alpha}]^{(i)}}}{(n_{ab,\alpha}!)^2} \right) \left(\prod_{\beta} \frac{\prod_i (\text{Tr } \mathcal{T}_{a,\beta}^i)^{[\sigma_{a,\beta}]^{(i)}}}{(n_{a,\beta}!)^2} \right) \left(\prod_{\gamma} \frac{\prod_i (\text{Tr } \bar{\mathcal{T}}_{a,\gamma}^i)^{[\bar{\sigma}_{a,\gamma}]^{(i)}}}{(\bar{n}_{a,\gamma}!)^2} \right) \\ &\quad \times \sum_{\Gamma_a} \delta \left(\Gamma_a (\times_{b,\alpha} \sigma_{ab,\alpha} \times_{\beta} \sigma_{a,\beta}) \Gamma_a^{-1} (\times_{b,\alpha} \sigma_{ba,\alpha} \times_{\gamma} \bar{\sigma}_{a,\gamma})^{-1} \right)\end{aligned}\quad (\text{B.1.8})$$

Finally, by summing over the now trivial $\vec{\rho}$ permutations we obtain

$$\begin{aligned}\mathcal{Z} &= \sum_{\vec{n}} \sum_{\vec{\sigma}} \prod_a \left(\prod_{b,\alpha} \frac{x_{ab,\alpha}^{\sum_i i [\sigma_{ab,\alpha}]^{(i)}}}{n_{ab,\alpha}!} \right) \left(\prod_{\beta} \frac{1}{n_{a,\beta}!} \right) \left(\prod_{\gamma} \frac{1}{\bar{n}_{a,\gamma}!} \right) \\ &\quad \times H_a(\{\sigma_{ab,\alpha}\}, \{\sigma_{a,\beta}\}, \{\bar{\sigma}_{a,\gamma}\}; \{\mathcal{T}_{a,\beta}\}, \{\bar{\mathcal{T}}_{a,\gamma}\})\end{aligned}\quad (\text{B.1.9})$$

where we defined

$$\begin{aligned}H_a(\{\sigma_{ab,\alpha}\}, \{\sigma_{a,\beta}\}, \{\bar{\sigma}_{a,\gamma}\}; \{\mathcal{T}_{a,\beta}\}, \{\bar{\mathcal{T}}_{a,\gamma}\}) &= \left(\prod_{\beta,i} (\text{Tr } \mathcal{T}_{a,\beta}^i)^{[\sigma_{a,\beta}]^{(i)}} \right) \left(\prod_{\gamma,i} (\text{Tr } \bar{\mathcal{T}}_{a,\gamma}^i)^{[\bar{\sigma}_{a,\gamma}]^{(i)}} \right) \\ &\quad \times \sum_{\Gamma_a} \delta \left(\Gamma_a (\times_{b,\alpha} \sigma_{ab,\alpha} \times_{\beta} \sigma_{a,\beta}) \Gamma_a^{-1} (\times_{b,\alpha} \sigma_{ba,\alpha} \times_{\gamma} \bar{\sigma}_{a,\gamma})^{-1} \right)\end{aligned}\quad (\text{B.1.10})$$

Eq. (B.1.9) is a function of the conjugacy class of the permutations σ , rather than of the permutations themselves. Exploiting this fact we can rewrite it as follows. Let us introduce the vectors of integers $\vec{p}_{ab,\alpha} = \cup_i \{p_{ab,\alpha}^{(i)}\}$, $\vec{p}_{a,\beta} = \cup_i \{p_{a,\beta}^{(i)}\}$ and $\vec{p}_{a,\gamma} = \cup_i \{\bar{p}_{a,\gamma}^{(i)}\}$. Here $p_{ab,\alpha}^{(i)}$ is the number of cycles of length i in the permutation $\sigma_{ab,\alpha}$, while $p_{a,\beta}^{(i)}$ and $\bar{p}_{a,\gamma}^{(i)}$ are the number of cycles of length i in the permutations $\sigma_{a,\beta}$ and $\bar{\sigma}_{a,\gamma}$ respectively. In accordance with eq. (B.1.4) we have

$$\sum_{i=1}^{\infty} i p_{ab,\alpha}^{(i)} = n_{ab,\alpha}, \quad |\vec{p}_{ab,\alpha}| = \frac{n_{ab,\alpha}!}{\prod_i p_{ab,\alpha}^{(i)} i^{p_{ab,\alpha}^{(i)}}}, \quad (\text{B.1.11})$$

and similarly for $\vec{p}_{a,\beta}$ and $\vec{p}_{a,\gamma}$. For notational purposes, it will be convenient to introduce the compact shorthand $\mathbf{p} = \cup_{ab,\alpha} \vec{p}_{ab,\alpha} \cup_{a,\beta} \vec{p}_{a,\beta} \cup_{a,\gamma} \vec{p}_{a,\gamma}$. With this notation we can rewrite (B.1.9)

as

$$\begin{aligned} \mathcal{Z} = \sum_{\vec{n}} \sum_{\mathbf{p}} \prod_a \left(\prod_{b,\alpha} \frac{|\vec{p}_{ab,\alpha}|}{n_{ab,\alpha}!} x_{ab,\alpha}^{\sum_i i p_{ab,\alpha}^{(i)}} \right) & \left(\prod_{\beta} \frac{|\vec{p}_{a,\beta}|}{n_{a,\beta}!} \right) \left(\prod_{\gamma} \frac{|\vec{p}_{a,\gamma}|}{\bar{n}_{a,\gamma}!} \right) \\ & \times H_a(\{\vec{p}_{ab,\alpha}\}, \{\vec{p}_{a,\beta}\}, \{\vec{p}_{a,\gamma}\}; \{\mathcal{T}_{a,\beta}\}, \{\bar{\mathcal{T}}_{a,\gamma}\}) \end{aligned} \quad (\text{B.1.12})$$

where now $H_a(\{\vec{p}_{ab,\alpha}\}, \{\vec{p}_{a,\beta}\}, \{\vec{p}_{a,\gamma}\}; \{\mathcal{T}_{a,\beta}\}, \{\bar{\mathcal{T}}_{a,\gamma}\})$ reads, after summing over the Γ_a permutations

$$\begin{aligned} H_a(\{\vec{p}_{ab,\alpha}\}, \{\vec{p}_{a,\beta}\}, \{\vec{p}_{a,\gamma}\}; \{\mathcal{T}_{a,\beta}\}, \{\bar{\mathcal{T}}_{a,\gamma}\}) &= \prod_i \left(\prod_{\beta} (\text{Tr } \mathcal{T}_{a,\beta}^i)^{p_{a,\beta}^{(i)}} \right) \left(\prod_{\gamma} (\text{Tr } \bar{\mathcal{T}}_{a,\gamma}^i)^{\bar{p}_{a,\gamma}^{(i)}} \right) \\ & \times \delta_a \left(\sum_{b,\alpha} (p_{ab,\alpha}^{(i)} - p_{ba,\alpha}^{(i)}) + \sum_{\beta} p_{a,\beta}^{(i)} - \sum_{\gamma} \bar{p}_{a,\gamma}^{(i)} \right) i^{\sum_{b,\alpha} p_{ba,\alpha}^{(i)} + \sum_{\gamma} \bar{p}_{a,\gamma}^{(i)}} \left(\sum_{b,\alpha} p_{ba,\alpha}^{(i)} + \sum_{\gamma} \bar{p}_{a,\gamma}^{(i)} \right)! \end{aligned} \quad (\text{B.1.13})$$

Using (B.1.13) and (B.1.11) in (B.1.12) gives then

$$\begin{aligned} \mathcal{Z} = \sum_{\mathbf{p}} \prod_i \prod_a \frac{(\sum_{b,\alpha} p_{ba,\alpha}^{(i)} + \sum_{\gamma} \bar{p}_{a,\gamma}^{(i)})!}{i^{\sum_{\beta} p_{a,\beta}^{(i)}}} & \left(\prod_{b,\alpha} \frac{x_{ab,\alpha}^{i p_{ab,\alpha}^{(i)}}}{p_{ab,\alpha}^{(i)}!} \right) \left(\prod_{\beta} \frac{(\text{Tr } \mathcal{T}_{a,\beta}^i)^{p_{a,\beta}^{(i)}}}{p_{a,\beta}^{(i)}!} \right) \\ & \times \left(\prod_{\gamma} \frac{(\text{Tr } \bar{\mathcal{T}}_{a,\gamma}^i)^{\bar{p}_{a,\gamma}^{(i)}}}{\bar{p}_{a,\gamma}^{(i)}!} \right) \delta_a \left(\sum_{b,\alpha} (p_{ab,\alpha}^{(i)} - p_{ba,\alpha}^{(i)}) + \sum_{\beta} p_{a,\beta}^{(i)} - \sum_{\gamma} \bar{p}_{a,\gamma}^{(i)} \right) \end{aligned} \quad (\text{B.1.14})$$

which is eq. (2.2.25).

Note that if we define the function $F^{[n]}(\{x_{ab}\}, \{t_a\}, \{\bar{t}_a\})$ as

$$\begin{aligned} F^{[n]}(\{x_{ab}\}, \{t_a\}, \{\bar{t}_a\}) &= \sum_{\vec{p}} \prod_{a=1}^n \left(\bar{p}_a + \sum_{b=1}^n p_{ba} \right)! \delta_a \left(p_a - \bar{p}_a + \sum_{b=1}^n (p_{ab} - p_{ba}) \right) \\ & \times \left(\prod_{b=1}^n \frac{x_{ab}^{p_{ab}}}{p_{ab}!} \right) \left(\frac{t_a^{p_a}}{p_a!} \right) \left(\frac{\bar{t}_a^{\bar{p}_a}}{\bar{p}_a!} \right) \end{aligned} \quad (\text{B.1.15})$$

where now $\vec{p} \equiv \cup_{a,b} \{p_{ab}\} \cup_a \{p_a, \bar{p}_a\}$, we can immediately obtain the generating function \mathcal{Z} (B.1.14) through the relation

$$\begin{aligned} \mathcal{Z}(\{x_{ab,\alpha}\}, \{\mathcal{T}_{a,\beta}\}, \{\bar{\mathcal{T}}_{a,\gamma}\}) &= \prod_i F^{[n]} \left(\left\{ x_{ab} \rightarrow \sum_{\alpha} x_{ab,\alpha}^i \right\}, \left\{ t_a \rightarrow \sum_{\beta} \frac{\text{Tr}(\mathcal{T}_{a,\beta}^i)}{i} \right\}, \left\{ \bar{t}_a \rightarrow \sum_{\gamma} \text{Tr}(\bar{\mathcal{T}}_{a,\gamma}^i) \right\} \right) \end{aligned} \quad (\text{B.1.16})$$

In fact, the RHS of (B.1.16) reads

$$\begin{aligned} & \prod_i \sum_{\vec{p}} \prod_a \left(\bar{p}_a + \sum_c p_{ca} \right)! \delta_a \left(p_a - \bar{p}_a + \sum_c (p_{ac} - p_{ca}) \right) \\ & \quad \times \left(\prod_b \frac{\left(\sum_\alpha x_{ab,\alpha}^i \right)^{p_{ab}}}{p_{ab}!} \right) \left(\frac{\left(\sum_\beta \frac{\text{Tr}(\mathcal{T}_{a,\beta}^i)}{i} \right)^{p_a}}{p_a!} \right) \left(\frac{\left(\sum_\gamma \text{Tr}(\bar{\mathcal{T}}_{a,\gamma}^i) \right)^{\bar{p}_a}}{\bar{p}_a!} \right) \end{aligned} \quad (\text{B.1.17})$$

and through the identity

$$\left(\sum_{a=1}^n z_a \right)^k = \sum_{\vec{p}} \delta \left(k - \sum_{a=1}^n p_a \right) k! \prod_{a=1}^n \frac{z_a^{p_a}}{p_a!}, \quad \vec{p} = (p_1, p_2, \dots, p_n) \quad (\text{B.1.18})$$

we can write (B.1.17) as

$$\begin{aligned} & \prod_i \sum_{\vec{p}} \prod_a \left(\bar{p}_a + \sum_b p_{ba} \right)! \delta_a \left(p_a - \bar{p}_a + \sum_b (p_{ab} - p_{ba}) \right) \\ & \quad \times \left(\sum_{\vec{p}_{ab}^{(i)}} \delta \left(p_{ab} - \sum_\alpha p_{ab,\alpha}^{(i)} \right) \prod_{b,\alpha} \frac{x_{ab,\alpha}^{ip_{ab,\alpha}^{(i)}}}{p_{ab,\alpha}^{(i)}!} \right) \\ & \quad \times \left(\sum_{\vec{p}_a^{(i)}} \delta \left(p_a - \sum_\beta p_{a,\beta}^{(i)} \right) \prod_\beta \frac{(\text{Tr} \mathcal{T}_{a,\beta}^i)^{p_{a,\beta}^{(i)}}}{i^{p_{a,\beta}^{(i)}} p_{a,\beta}^{(i)}!} \right) \left(\sum_{\vec{p}_a^{(i)}} \delta \left(\bar{p}_a - \sum_\gamma \bar{p}_{a,\gamma}^{(i)} \right) \prod_\gamma \frac{(\text{Tr} \bar{\mathcal{T}}_{a,\gamma}^i)^{\bar{p}_{a,\gamma}^{(i)}}}{\bar{p}_{a,\gamma}^{(i)}!} \right) \end{aligned} \quad (\text{B.1.19})$$

where $\vec{p}_{ab}^{(i)} = \cup_{b,\alpha} \{p_{ab,\alpha}^{(i)}\}$, $\vec{p}_a^{(i)} = \cup_\beta \{p_{a,\beta}^{(i)}\}$ and $\vec{\bar{p}}_a^{(i)} = \cup_\gamma \{\bar{p}_{a,\gamma}^{(i)}\}$. Summing over \vec{p} gives, exploiting

the second, third and fourth Kronecker deltas in the expression above

$$\begin{aligned}
 & \prod_i \prod_a \sum_{\vec{p}_{ab}^{(i)}} \sum_{\vec{p}_a^{(i)}} \sum_{\vec{p}_a^{(i)}} \left(\sum_{b,\alpha} p_{ba,\alpha}^{(i)} + \sum_{\gamma} \bar{p}_{a,\gamma}^{(i)} \right)! \delta_a \left(\sum_{b,\alpha} (p_{ab,\alpha}^{(i)} - p_{ba,\alpha}^{(i)}) + \sum_{\beta} p_{a,\beta}^{(i)} - \sum_{\gamma} \bar{p}_{a,\gamma}^{(i)} \right) \\
 & \times \left(\prod_{b,\alpha} \frac{x_{ab,\alpha}^{ip_{ab,\alpha}^{(i)}}}{p_{ab,\alpha}^{(i)}} \right) \left(\prod_{\beta} \frac{(\text{Tr } \mathcal{T}_{a,\beta}^i)^{p_{a,\beta}^{(i)}}}{i^{p_{a,\beta}^{(i)}} p_{a,\beta}^{(i)}!} \right) \left(\prod_{\gamma} \frac{(\text{Tr } \bar{\mathcal{T}}_{a,\gamma}^i)^{\bar{p}_{a,\gamma}^{(i)}}}{\bar{p}_{a,\gamma}^{(i)}!} \right) \\
 & = \sum_{\mathbf{p}} \prod_i \prod_a \frac{(\sum_{b,\alpha} p_{ba,\alpha}^{(i)} + \sum_{\gamma} \bar{p}_{a,\gamma}^{(i)})!}{i^{\sum_{\beta} p_{a,\beta}^{(i)}}} \left(\prod_{b,\alpha} \frac{x_{ab,\alpha}^{ip_{ab,\alpha}^{(i)}}}{p_{ab,\alpha}^{(i)}} \right) \left(\prod_{\beta} \frac{(\text{Tr } \mathcal{T}_{a,\beta}^i)^{p_{a,\beta}^{(i)}}}{p_{a,\beta}^{(i)}!} \right) \\
 & \times \left(\prod_{\gamma} \frac{(\text{Tr } \bar{\mathcal{T}}_{a,\gamma}^i)^{\bar{p}_{a,\gamma}^{(i)}}}{\bar{p}_{a,\gamma}^{(i)}!} \right) \delta_a \left(\sum_{b,\alpha} (p_{ab,\alpha}^{(i)} - p_{ba,\alpha}^{(i)}) + \sum_{\beta} p_{a,\beta}^{(i)} - \sum_{\gamma} \bar{p}_{a,\gamma}^{(i)} \right) = \mathcal{Z} \quad (\text{B.1.20})
 \end{aligned}$$

where in the second equality we used $\mathbf{p} \equiv \cup_{b,\alpha} \vec{p}_{ab,\alpha} \cup_{a,\beta} \vec{p}_{a,\beta} \cup_{a,\gamma} \vec{p}_{a,\gamma}$ and the third one follows from (B.1.14). We can now appreciate how every property of \mathcal{Z} is determined by the $F^{[n]}$ function, which will play the role of fundamental building block of the generating function. In the following we will then focus mainly on the latter, which will improve the clarity of the exposition: the generating function Z can be obtained at any time through the relation (B.1.16).

B.1.2 A contour integral formulation for $F^{[n]}$

All of the Kronecker deltas δ_a in eq. (B.1.15) ensure that, at each node a in the quiver, there are as many fields flowing in as there are flowing out, ensuring the balance of the incoming and outgoing edge variables p_{ab} , p_a , \bar{p}_a . Using the contour integral resolution of the Kronecker delta

$$\delta_a = \oint_{\mathcal{C}} \frac{dz}{2\pi iz} z^a, \quad (\text{B.1.21})$$

where \mathcal{C} is a closed path that encloses the origin, we can write a contour integral formulation for $F^{[n]}$, and thus for \mathcal{Z} . Let us then use (B.1.21) in (B.1.15), to get

$$F^{[n]} = \sum_{\vec{p}} \prod_a \left(\bar{p}_a + \sum_c p_{ca} \right)! \left(\prod_b \frac{x_{ab}^{p_{ab}}}{p_{ab}!} \right) \left(\frac{t_a^{p_a}}{p_a!} \right) \left(\frac{\bar{t}_a^{\bar{p}_a}}{\bar{p}_a!} \right) \oint_{\mathcal{C}_a} \frac{dz_a}{2\pi iz_a} z_a^{p_a - \bar{p}_a + \sum_b (p_{ab} - p_{ba})} \quad (\text{B.1.22})$$

or, conveniently rearranging the integrands above,

$$\begin{aligned}
 F^{[n]} &= \sum_{\bar{p}} \left(\prod_a \oint_{\mathcal{C}_a} \frac{dz_a}{2\pi i z_a} \right) \prod_a \left(\prod_b \frac{(z_b x_{ba} z_a^{-1})^{p_{ba}}}{p_{ba}!} \right) \left(\frac{(z_a t_a)^{p_a}}{p_a!} \right) \\
 &\quad \times \left(\bar{p}_a + \sum_c p_{ca} \right)! \left(\frac{(z_a^{-1} \bar{t}_a)^{\bar{p}_a}}{\bar{p}_a!} \right)
 \end{aligned} \tag{B.1.23}$$

Summing over the p_a s gives the exponentials

$$\sum_{p_a} \frac{(z_a t_a)^{p_a}}{p_a!} = \exp(z_a t_a) \tag{B.1.24}$$

while it is a little bit trickier to sum over the \bar{p}_a s. Using the identity

$$\left(\bar{p}_a + \sum_c p_{ca} \right)! = \left(\sum_c p_{ca} \right)! \left(1 + \sum_c p_{ca} \right)_{(\bar{p}_a)} \tag{B.1.25}$$

where $(a)_n = a(a+1)\cdots(a+n-1)$ is the Pochhammer symbol, we can rewrite (B.1.23) as

$$\begin{aligned}
 F^{[n]} &= \left(\prod_a \sum_{\bar{p}_a, \bar{p}_a} \oint_{\mathcal{C}_a} \frac{dz_a}{2\pi i z_a} \right) \prod_a \left(\sum_c p_{ca} \right)! \left(\prod_b \frac{(z_b x_{ba} z_a^{-1})^{p_{ba}}}{p_{ba}!} \right) \\
 &\quad \times \exp(z_a t_a) \left(1 + \sum_c p_{ca} \right)_{(\bar{p}_a)} \left(\frac{(z_a^{-1} \bar{t}_a)^{\bar{p}_a}}{\bar{p}_a!} \right)
 \end{aligned} \tag{B.1.26}$$

where we also used (B.1.24). In the following section B.1.2 we show that

$$\sum_{\bar{p}_a} \left(1 + \sum_c p_{ca} \right)_{(\bar{p}_a)} \left(\frac{(z_a^{-1} \bar{t}_a)^{\bar{p}_a}}{\bar{p}_a!} \right) = \left(\frac{1}{1 - z_a^{-1} \bar{t}_a} \right)^{1 + \sum_c p_{ca}} \tag{B.1.27}$$

We impose absolute convergence of the sums on the LHS, which ensures that we can swap the sum and integral symbols in (B.1.26). Using (B.1.27) in (B.1.26), we can write $F^{[n]}$ as

$$F^{[n]} = \left(\prod_a \sum_{\bar{p}_a} \oint_{\mathcal{C}_a} \frac{dz_a}{2\pi i z_a} \right) \prod_a \frac{\exp(z_a t_a)}{1 - z_a^{-1} \bar{t}_a} \left(\sum_c p_{ca} \right)! \prod_b \frac{1}{p_{ba}!} \left(\frac{z_b x_{ba} z_a^{-1}}{1 - z_a^{-1} \bar{t}_a} \right)^{p_{ba}} \tag{B.1.28}$$

Now we just have to compute the p_{ab} sums. In section B.1.2 we show that

$$\left(\prod_b \sum_{p_{ba}} \right) \left(\sum_b p_{ba} \right)! \prod_b \frac{1}{p_{ba}!} \left(\frac{z_b x_{ba} z_a^{-1}}{1 - z_a^{-1} \bar{t}_a} \right)^{p_{ba}} = \frac{1 - z_a^{-1} \bar{t}_a}{1 - z_a^{-1} (\bar{t}_a + \sum_b z_b x_{ba})} \tag{B.1.29}$$

where again we impose the absolute convergence of all the sums on the LHS, for the same reason just discussed. Eq. (B.1.28) has now become

$$F^{[n]}(\{x_{ab}\}, \{t_a\}, \{\bar{t}_a\}) = \left(\prod_a \oint_{\mathcal{C}_a} \frac{dz_a}{2\pi i z_a} \right) \prod_a \frac{\exp(z_a t_a)}{1 - z_a^{-1} (\bar{t}_a + \sum_b z_b x_{ba})} \quad (\text{B.1.30})$$

We can rewrite the latter equation more compactly as

$$F^{[n]}(\{x_{ab}\}, \{t_a\}, \{\bar{t}_a\}) = \left(\prod_a \oint_{\mathcal{C}_a} \frac{dz_a}{2\pi i} \right) \prod_a I_a(\vec{z}; \vec{x}_a, t_a, \bar{t}_a) \quad (\text{B.1.31})$$

where $\vec{z} = (z_1, z_2, \dots, z_n)$, n being the number of nodes of the quiver, $\vec{x}_a = \cup_b \{x_{ba}\}$ and

$$I_a(\vec{z}; \vec{x}_a, t_a, \bar{t}_a) = \frac{\exp(z_a t_a)}{z_a - (\bar{t}_a + \sum_b z_b x_{ba})} \quad (\text{B.1.32})$$

Eq. (2.2.28) is thus obtained.

Summing over \bar{p}_a

We want to prove eq (B.1.27)

$$\sum_{\bar{p}_a} \left(1 + \sum_c p_{ca} \right)_{(\bar{p}_a)} \left(\frac{(z_a^{-1} \bar{t}_a)^{\bar{p}_a}}{\bar{p}_a!} \right) = \left(\frac{1}{1 - z_a^{-1} \bar{t}_a} \right)^{1 + \sum_c p_{ca}} \quad (\text{B.1.33})$$

for any node a of the quiver. We also have to take care about the convergence of all the sums on the LHS of this equation. These z_a variables will eventually be integrated over closed curves \mathcal{C}_a in the complex plane, which we will use to compute the contour integrals in (B.1.26) through residues theorem. As discussed in the previous section, we require absolute convergence of the sums on the LHS,

$$\sum_{\bar{p}_a} \left(1 + \sum_c p_{ca} \right)_{(\bar{p}_a)} \left| \frac{(z_a^{-1} \bar{t}_a)^{\bar{p}_a}}{\bar{p}_a!} \right| < \infty \quad (\text{B.1.34})$$

Throughout this section we will therefore restrict to the z_a that satisfy this constraint. With the mappings

$$x \rightarrow 1 + \sum_c p_{ca} \quad (\text{B.1.35})$$

$$z \rightarrow z_a^{-1} \bar{t}_a \quad (\text{B.1.36})$$

the equality (B.1.33) reads

$$\sum_p (x)_{(p)} \frac{z^p}{p!} = \frac{1}{(1-z)^x} \quad (\text{B.1.37})$$

This is a known identity, and can be derived with the chain of equalities

$$\frac{1}{(1-z)^x} = \sum_{p=0}^{\infty} \binom{p+x-1}{p} z^p = \sum_{p=0}^{\infty} \frac{(p+x-1)!}{(x-1)! p!} z^p = \sum_{p=0}^{\infty} \frac{(x)_{(p)}}{p!} z^p \quad (\text{B.1.38})$$

The first step above holds only when $|z| < 1$. Our proposition is thus proven.

Summing over p_{ab}

We want now to prove (B.1.29), for each node a of the quiver:

$$\left(\prod_b \sum_{p_{ba}} \right) \left(\sum_b p_{ba} \right)! \prod_b \frac{1}{p_{ba}!} \left(\frac{z_b x_{ba} z_a^{-1}}{1 - z_a^{-1} \bar{t}_a} \right)^{p_{ba}} = \frac{1 - z_a^{-1} \bar{t}_a}{1 - z_a^{-1} (\bar{t}_a + \sum_b z_b x_{ba})} \quad (\text{B.1.39})$$

As in the previous section, we work in a region of the $\cup_a \{z_a\}$ variables where the sums converge absolutely:

$$\left(\prod_b \sum_{p_{ba}} \right) \left(\sum_b p_{ba} \right)! \prod_b \frac{1}{p_{ba}!} \left| \frac{z_b x_{ba} z_a^{-1}}{1 - z_a^{-1} \bar{t}_a} \right|^{p_{ba}} < \infty \quad (\text{B.1.40})$$

and we will restrict our computation to the set of $\cup_a \{z_a\}$ that satisfy such a constraint.

Let us then prove the simpler identity

$$\sum_{\vec{p}} \left(\sum_b p_b \right)! \prod_b \frac{1}{p_b!} \left(\frac{z_b}{1-y} \right)^{p_b} = \frac{1-y}{1 - \left(y + \sum_b z_b \right)} \quad (\text{B.1.41})$$

with $\vec{p} = \cup_b \{p_b\}$, which turns into (B.1.39) through the mappings

$$z_b \rightarrow z_b x_{ba} z_a^{-1}, \quad y \rightarrow z_a^{-1} \bar{t}_a, \quad p_b \rightarrow p_{ba} \quad (\text{B.1.42})$$

Similarly, the condition for absolute convergence (B.1.40) becomes

$$\sum_{\vec{p}} \left(\sum_b p_b \right)! \prod_b \frac{1}{p_b!} \left| \frac{z_b}{1-y} \right|^{p_b} < \infty \quad (\text{B.1.43})$$

We will prove (B.1.41) twice, starting from its right hand side, by choosing two different

ways of factorising the ratio

$$\frac{1-y}{1-\left(y+\sum_b z_b\right)}=\frac{1-y}{\left(1-z_a\right)-\left(y+\sum_{b \neq a} z_b\right)} \quad (\text{B.1.44})$$

In the first one we will factor out the term $(1-y)/(1-z_a)$ and in the second one the term $(1-y)/(1-(y+\sum_{b \neq c} z_b))$. We will then expand in power series the remaining part of each expression, to obtain two different power expansions. The upshot is that we will obtain two different sets of constraints for the convergence of the power series. Both sets of constraints will hold in the region of absolute convergence (B.1.40), and they will determine the pole prescription for the contour integrals in (2.2.28).

First factorisation

We start from the RHS of eq. (B.1.41). We are going to factor out the term $(1-y)/(1-z_a)$ and expand in a power series the remaining part of the expression. Let us then write

$$\frac{1-y}{1-\left(y+\sum_b z_b\right)}=\frac{1-y}{1-z_a} \frac{1}{1-\left(\frac{y+\sum_{b \neq a} z_b}{1-z_a}\right)} \quad (\text{B.1.45})$$

and let us expand the second factor on the RHS above to get

$$\frac{1-y}{1-\left(y+\sum_b z_b\right)}=\frac{1-y}{1-z_a} \sum_{n=0}^{\infty}\left(\frac{y+\sum_{b \neq a} z_b}{1-z_a}\right)^n \quad (\text{B.1.46})$$

with the constraint

$$\left|\frac{y+\sum_{b \neq a} z_b}{1-z_a}\right|<1 \quad (\text{B.1.47})$$

We now rewrite eq. (B.1.46) as

$$\frac{1-y}{1-\left(y+\sum_b z_b\right)}=(1-y) \sum_{n=0}^{\infty}\left(y+\sum_{b \neq a} z_b\right)^n \frac{1}{\left(1-z_a\right)^{n+1}} \quad (\text{B.1.48})$$

in order to expand the two terms $\left(y+\sum_{b \neq a} z_b\right)^n$ and $\left(1-z_a\right)^{-(n+1)}$ separately. For the first one we get

$$\left(y+\sum_{b \neq a} z_b\right)^n=\left(\prod_{b \neq a} \sum_{p_b=0}^{\infty}\right) \sum_{p_y=0}^{\infty} \frac{y^{p_y}}{p_y!} n! \delta\left(n-p_y-\sum_{b \neq a} p_b\right) \prod_{b \neq a} \frac{z_b^{p_b}}{p_b!} \quad (\text{B.1.49})$$

while for the second one, using eq. (B.1.38), we obtain

$$\frac{1}{(1-z_a)^{n+1}} = \sum_{p_a=0}^{\infty} \frac{(p_a+n)!}{n!} \frac{z_a^{p_a}}{p_a!} \quad (\text{B.1.50})$$

The last equality is valid for $|z_a| < 1$. Inserting eqs. (B.1.49) and (B.1.50) into eq. (B.1.48), and rearranging the order of the sums⁷ to let the sum over n act first we get

$$\begin{aligned} \frac{1-y}{1-\left(y+\sum_b z_b\right)} &= (1-y) \sum_{n=0}^{\infty} \sum_{\vec{p}} \sum_{p_y=0}^{\infty} \frac{y^{p_y}}{p_y!} \delta\left(n-p_y-\sum_{b \neq a} p_b\right) (p_a+n)! \prod_b \frac{z_b^{p_b}}{p_b!} \\ &= (1-y) \sum_{\vec{p}} \sum_{p_y=0}^{\infty} \frac{y^{p_y}}{p_y!} \left(p_y+\sum_b p_b\right)! \prod_b \frac{z_b^{p_b}}{p_b!} \end{aligned} \quad (\text{B.1.51})$$

Now, since

$$\sum_{n=0}^{\infty} \frac{(a+n)!}{n!} y^n = a! \frac{1}{(1-y)^{1+a}}, \quad |y| < 1 \quad (\text{B.1.52})$$

we can sum over p_y in the last line of eq. (B.1.51) to obtain

$$\begin{aligned} \frac{1-y}{1-\left(y+\sum_b z_b\right)} &= (1-y) \sum_{\vec{p}} \frac{(\sum_b p_b)!}{(1-y)^{1+\sum_b p_b}} \prod_b \frac{z_b^{p_b}}{p_b!} = \sum_{\vec{p}} \frac{(\sum_b p_b)!}{\prod_b (1-y)^{p_b}} \prod_b \frac{z_b^{p_b}}{p_b!} \\ &= \sum_{\vec{p}} \left(\sum_b p_b\right)! \prod_b \frac{1}{p_b!} \left(\frac{z_b}{1-y}\right)^{p_b} \end{aligned} \quad (\text{B.1.53})$$

together with the constraint

$$|y| < 1 \quad (\text{B.1.54})$$

Eq. (B.1.53) is exactly eq. (B.1.41), which becomes our initial proposition (B.1.39) through the substitutions (B.1.42). In the steps presented above, we got three constraints:

$$\left\{ \left| \frac{y + \sum_{b \neq a} z_b}{1 - z_a} \right| < 1 \right\}, \quad \{|z_a| < 1\}, \quad \{|y| < 1\} \quad (\text{B.1.55})$$

⁷Since we are only considering $\{z_a\}$ variables that satisfy absolute convergence condition (B.1.43), this is a legitimate operation.

The first one becomes, through the substitutions (B.1.42),

$$\left\{ \left| \frac{z_a^{-1} \bar{t}_a + \sum_{b \neq a} z_b x_{ba} z_a^{-1}}{1 - x_{aa}} \right| < 1 \right\} \quad (\text{B.1.56})$$

which we can also write as the set \mathcal{K}_a^+

$$\mathcal{K}_a^+ = \left\{ z_a \in \mathbb{C} \text{ s.t. } |z_a| > \left| \frac{\bar{t}_a + \sum_{b \neq a} z_b x_{ba}}{1 - x_{aa}} \right| \right\} \quad (\text{B.1.57})$$

We stress that the set of $\cup_a \{z_a\}$ that satisfy the latter constraint *includes* the set of $\cup_a \{z_a\}$ that makes the sums in (B.1.41) absolutely convergent, to which we restricted our computation. On the other hand, imposing (B.1.55) alone would not be enough to guarantee the validity of all the steps presented in this section.

Second factorisation

We will now show (B.1.39) in a different way, again starting from the RHS of eq. (B.1.41). This time we factor out the term $(1 - y)/(1 - (y + \sum_{b \neq c} z_b))$, to expand in a power series the remaining part of the expression. Let us then begin by writing

$$\begin{aligned} \frac{1 - y}{1 - \left(y + \sum_b z_b\right)} &= \frac{1 - y}{\left(1 - \left(y + \sum_{b \neq c} z_b\right)\right) - z_c} \\ &= \frac{1 - y}{1 - \left(y + \sum_{b \neq c} z_b\right)} \frac{1}{1 - \frac{z_c}{1 - \left(y + \sum_{b \neq c} z_b\right)}} \end{aligned} \quad (\text{B.1.58})$$

Now we expand the second term in the line above in power series, to get

$$\frac{1 - y}{1 - \left(y + \sum_b z_b\right)} = \frac{1 - y}{1 - \left(y + \sum_{b \neq c} z_b\right)} \sum_{n=0}^{\infty} \left(\frac{z_c}{1 - \left(y + \sum_{b \neq c} z_b\right)} \right)^n \quad (\text{B.1.59})$$

along with the constraint

$$\left| \frac{z_c}{1 - \left(y + \sum_{b \neq c} z_b \right)} \right| < 1 \quad (\text{B.1.60})$$

All these steps are similar to the ones in eqs. (B.1.41)-(B.1.47). Proceeding in the same fashion we first write

$$\frac{1-y}{1 - \left(y + \sum_b z_b \right)} = (1-y) \sum_{n=0}^{\infty} z_c^n \frac{1}{\left(1 - \left(y + \sum_{b \neq c} z_b \right) \right)^{n+1}} \quad (\text{B.1.61})$$

Then we expand the rational part of the RHS in power series, rearranging the order of the sums in such a way that the sum over k acts first, to get

$$\begin{aligned} \frac{1}{\left(1 - \left(y + \sum_{b \neq c} z_b \right) \right)^{n+1}} &= \sum_{k=0}^{\infty} \frac{(k+n)!}{k! n!} \left(y + \sum_{b \neq c} z_b \right)^k \\ &= \sum_{k=0}^{\infty} \frac{(k+n)!}{k! n!} \left(\prod_{b \neq c} \sum_{p_b=0}^{\infty} \right) \sum_{p_y=0}^{\infty} \frac{y^{p_y}}{p_y!} \delta \left(k - p_y - \sum_{b \neq c} p_b \right) k! \prod_{b \neq c} \frac{z_b^{p_b}}{p_b!} \\ &= \left(\prod_{b \neq c} \sum_{p_b=0}^{\infty} \right) \sum_{p_y=0}^{\infty} \frac{y^{p_y}}{p_y!} \frac{(n + p_y + \sum_{b \neq c} p_b)!}{n!} \prod_{b \neq c} \frac{z_b^{p_b}}{p_b!} \end{aligned} \quad (\text{B.1.62})$$

together with the constraint (coming from the first equality)

$$\left| y + \sum_{b \neq c} z_b \right| < 1 \quad (\text{B.1.63})$$

Using eq. (B.1.62) in (B.1.61) we get

$$\begin{aligned} \frac{1-y}{1 - \left(y + \sum_b z_b \right)} &= (1-y) \sum_{n=0}^{\infty} \sum_{\vec{p}} \sum_{p_y=0}^{\infty} \frac{y^{p_y}}{p_y!} \delta(p_c - n) \left(n + p_y + \sum_{b \neq c} p_b \right)! \prod_b \frac{z_b^{p_b}}{p_b!} \\ &= (1-y) \sum_{\vec{p}} \sum_{p_y=0}^{\infty} \frac{y^{p_y}}{p_y!} \left(p_y + \sum_b p_b \right)! \prod_b \frac{z_b^{p_b}}{p_b!} \end{aligned} \quad (\text{B.1.64})$$

where we again rearranged the order of the sums to let the sum over n act first. Now this equation is identical to eq. (B.1.51), and we know that if we impose the constraint

$$|y| < 1 \tag{B.1.65}$$

(B.1.64) is enough to prove (B.1.39). Our initial proposition is again proven.

In the derivation we got, among others, the constraint

$$\left\{ \left| \frac{z_c}{1 - \left(y + \sum_{b \neq c} z_b \right)} \right| < 1 \right\} \tag{B.1.66}$$

which with the substitutions (B.1.42) becomes

$$\left\{ \left| \frac{z_c x_{ca} z_a^{-1}}{1 - \left(z_a^{-1} \bar{t}_a + \sum_{b \neq c} z_b x_{ba} z_a^{-1} \right)} \right| < 1 \right\} \tag{B.1.67}$$

The same quantity can also be described in terms of the set $k_{c,a}^-$, defined as

$$k_{c,a}^- = \left\{ z_c \in \mathbb{C} \text{ s.t. } |z_c| < \left| \frac{z_a - \left(\bar{t}_a + \sum_{b \neq c} z_b x_{ba} \right)}{x_{ca}} \right| \right\} \tag{B.1.68}$$

This constraint has to be interpreted in the same manner as the one in (B.1.57): $k_{c,a}^-$ includes the set of $\cup_a \{z_a\}$ that makes (B.1.41) absolutely convergent.

Fixing node a , the derivation above holds for any $c \neq a$. This means that we can obtain constraints like the one in (B.1.66) for all the nodes $c \neq a$ of the quiver, that we can impose *all at the same time*. We can then define the set

$$\mathcal{K}_a^- = \bigcap_{c \neq a} k_{c,a}^- = \bigcap_{c \neq a} \left\{ z_c \in \mathbb{C} \text{ s.t. } |z_c| < \left| \frac{z_c - \left(\bar{t}_a + \sum_{b \neq c} z_b x_{ba} \right)}{x_{ca}} \right| \right\} \tag{B.1.69}$$

Just like \mathcal{K}_a^+ (eq. (B.1.57)), this constraint will be of central importance when we will compute

the integrals in (2.2.28): the set \mathcal{K}_a , defined as

$$\begin{aligned} \mathcal{K}_a &= \mathcal{K}_a^+ \cap \mathcal{K}_a^- \\ &= \left\{ z_a \in \mathbb{C} \text{ s.t. } |z_a| > \left| \frac{\bar{t}_a + \sum_{b \neq a} z_b x_{ba}}{1 - x_{aa}} \right| \right\} \\ &\quad \bigcap_{c \neq a} \left\{ z_c \in \mathbb{C} \text{ s.t. } |z_c| < \left| \frac{z_c - \left(\bar{t}_a + \sum_{b \neq c} z_b x_{ba} \right)}{x_{ca}} \right| \right\} \end{aligned} \quad (\text{B.1.70})$$

will in fact determine which poles are to be included by the contour \mathcal{C}_a .

B.2 Residues and constraints

In this appendix we will present the rule for including/excluding poles when calculating the contour integrals in eq. (2.2.28), that is

$$F^{[n]}(\{x_{ab}\}, \{t_a\}, \{\bar{t}_a\}) = \left(\prod_a \oint_{\mathcal{C}_a} \frac{dz_a}{2\pi i} \right) \prod_a I_a(\vec{z}; \vec{x}_a, t_a, \bar{t}_a) \quad (\text{B.2.1})$$

We recall that the integrands I_a are defined by

$$I_a(\vec{z}; \vec{x}_a, t_a, \bar{t}_a) = \frac{\exp(z_a t_a)}{z_a - (\bar{t}_a + \sum_b z_b x_{ba})} \quad (\text{B.2.2})$$

The prescription is that we have to pick only the z_a pole coming from the I_a factor in the integrand of (B.2.1), for each a . Let us show how this rule arises.

If the quiver under study has n nodes, each I_a will have n poles, one for each z variable. Explicitly

$$z_a^* = \frac{\bar{t}_a + \sum_{b \neq a} z_b x_{ba}}{1 - x_{aa}}, \quad z_c^* = \frac{z_a - \left(\bar{t}_a + \sum_{b \neq c} z_b x_{ba} \right)}{x_{ca}}, \quad \forall c \neq a \quad (\text{B.2.3})$$

From appendix B.1.2 we know however that we have to restrict to the set of $\cup_a \{z_a\}$ that belongs

to the intersection of the set (B.1.70)

$$\begin{aligned}
 \mathcal{K}_a &= \left\{ z_a \in \mathbb{C} \text{ s.t. } |z_a| > \left| \frac{\bar{t}_a + \sum_{b \neq a} z_b x_{ba}}{1 - x_{aa}} \right| \right\} \\
 &\quad \bigcap_{c \neq a} \left\{ z_c \in \mathbb{C} \text{ s.t. } |z_c| < \left| \frac{z_a - \left(\bar{t}_a + \sum_{b \neq c} z_b x_{ba} \right)}{x_{ca}} \right| \right\} \\
 &= \{z_a \in \mathbb{C} \text{ s.t. } |z_a| > |z_a^*|\} \bigcap_{c \neq a} \{z_c \in \mathbb{C} \text{ s.t. } |z_c| < |z_c^*|\}
 \end{aligned} \tag{B.2.4}$$

with the set of $\cup_a \{z_a\}$ satisfying the condition of absolute convergence (B.1.40):

$$\left(\prod_b \sum_{p_{ba}} \right) \left(\sum_b p_{ba} \right)! \prod_b \frac{1}{p_{ba}!} \left| \frac{z_b x_{ba} z_a^{-1}}{1 - z_a^{-1} \bar{t}_a} \right|^{p_{ba}} < \infty \tag{B.2.5}$$

In the same appendix, we also argued that the former constraint (B.2.4) includes the latter (B.2.5): this means that if we impose (B.2.5), then (B.2.4) is also valid. But this is telling us that for *any* I_a we only have to pick up the pole relative to the z_a variable, and discard all the others. However this is a prescription which holds only before we perform any integration: after we do so, the poles for each of the remaining z variables will have a different equation. This problem is anyway easily overcome: the constraint in (B.2.4) comes from the sums in (B.1.28) that contribute to the I_a piece of the integrand (B.2.1) alone. So in principle we could have chosen any a in (B.1.28), performed the sums over $\cup_b p_{ba}$ only, got the I_a term together with the constraint above, inferred from the previous discussion that only the z_a pole has to be picked up and finally compute the z_a integration (all the other z_a appearing in (B.1.28) are regular and have no pole). Let us then imagine to be in such a situation, and for concreteness say that we have chosen to integrate over z_1 . After the z_1 integration has been done, we are left with $n - 1$ sums (n being the number of nodes in the quiver) of the form already discussed in appendix B.1.2, that is

$$\left(\prod_b \sum_{p_{ba}} \right) \left(\sum_b p_{ba} \right)! \prod_b \frac{1}{p_{ba}!} \left(\frac{z_b x_{ba} z_a^{-1}}{1 - z_a^{-1} \bar{t}_a} \right)^{p_{ba}} = \frac{1 - z_a^{-1} \bar{t}_a}{1 - z_a^{-1} (\bar{t}_a + \sum_b z_b x_{ba})}, \quad a \neq 1 \tag{B.2.6}$$

where now every z_1 has to be substituted with its pole equation, which will be of the form

$$z_1 \rightarrow z_1^*(z_2, z_3, \dots, z_n; \vec{x}) = \sum_{c > 1} z_c a_c \tag{B.2.7}$$

for some coefficients a_c . As usual, we impose absolute convergence of the sums on the LHS

of (B.2.6). Adapting the notation of appendix B.1.2 to the present case, let us work with the simpler identity

$$\left(\prod_b \sum_{p_b=0}^{\infty} \right) \left(\sum_b p_b \right)! \left(\prod_{b>1} \frac{z_b^{p_b}}{p_b!} \right) \frac{(z_1^*)^{p_1}}{p_1!} = \frac{1}{1 - \sum_{b>1} z_b - z_1^*} \quad (\text{B.2.8})$$

which becomes (B.2.6) through the substitutions

$$z_b \rightarrow \frac{z_b x_{ba} z_a^{-1}}{1 - z_a^{-1} \bar{t}_a}, \quad p_b \rightarrow p_{ba} \quad (\text{B.2.9})$$

Note that now we have

$$z_1^* \rightarrow \frac{z_1^* x_{1a} z_a^{-1}}{1 - z_a^{-1} \bar{t}_a} = \sum_{c>1} \frac{z_c a_c x_{1a} z_a^{-1}}{1 - z_a^{-1} \bar{t}_a} = \sum_{c>1} \frac{z_c \tilde{x}_{ca} z_a^{-1}}{1 - z_a^{-1} \bar{t}_a} = \sum_{c>1} \tilde{z}_c \quad (\text{B.2.10})$$

in which we defined

$$\tilde{x}_{ca} = a_c x_{1a}, \quad \tilde{z}_c = \frac{z_c \tilde{x}_{ca} z_a^{-1}}{1 - z_a^{-1} \bar{t}_a} \quad (\text{B.2.11})$$

Consider now the LHS of (B.2.8) and write it as

$$\begin{aligned} & \left(\prod_b \sum_{p_b=0}^{\infty} \right) \left(\sum_b p_b \right)! \left(\prod_{b>1} \frac{z_b^{p_b}}{p_b!} \right) \frac{(z_1^*)^{p_1}}{p_1!} = \left(\prod_b \sum_{p_b=0}^{\infty} \right) \left(\sum_b p_b \right)! \left(\prod_{b>1} \frac{z_b^{p_b}}{p_b!} \right) \frac{1}{p_1!} \left(\sum_{c>1} \tilde{z}_c \right)^{p_1} \\ & = \left(\prod_b \sum_{p_b=0}^{\infty} \right) \left(\sum_b p_b \right)! \left(\prod_{b>1} \frac{z_b^{p_b}}{p_b!} \right) \left(\prod_{c>1} \sum_{q_c=0}^{\infty} \right) \delta \left(p_1 - \sum_{c>1} q_c \right) \prod_{c>1} \frac{\tilde{z}_c^{q_c}}{q_c!} \end{aligned} \quad (\text{B.2.12})$$

After summing over p_1 we obtain

$$\begin{aligned} & \left(\prod_b \sum_{p_b=0}^{\infty} \right) \left(\sum_b p_b \right)! \left(\prod_{b>1} \frac{z_b^{p_b}}{p_b!} \right) \frac{(z_1^*)^{p_1}}{p_1!} \\ & = \left(\prod_{b>1} \sum_{\substack{p_b=0 \\ q_b=0}}^{\infty} \right) \left(\sum_{b>1} p_b + \sum_{c>1} q_c \right)! \left(\prod_{b>1} \frac{z_b^{p_b}}{p_b!} \right) \prod_{c>1} \frac{\tilde{z}_c^{q_c}}{q_c!} \\ & = \left(\prod_{b>1} \sum_{\substack{p_b=0 \\ q_b=0}}^{\infty} \right) \left(\sum_{b>1} (p_b + q_b) \right)! \left(\prod_{b>1} \frac{z_b^{p_b}}{p_b!} \frac{\tilde{z}_b^{q_b}}{q_b!} \right) \end{aligned} \quad (\text{B.2.13})$$

where the last equality follows from noticing that the b and c labels in the products and sums run over the same set of variables. Now multiplying the far right hand side of the above equation

by $\prod_{b>1} \frac{(p_b+q_b)!}{(p_b+q_b)!} = 1$ and inserting the identity

$$\prod_{b>1} \sum_{\lambda_b=0}^{\infty} \delta(\lambda_b - p_b - q_b) = 1, \quad (\text{B.2.14})$$

we get, exploiting the support of the delta function

$$\begin{aligned} & \left(\prod_b \sum_{p_b=0}^{\infty} \right) \left(\sum_b p_b \right)! \left(\prod_{b>1} \frac{z_b^{p_b}}{p_b!} \right) \frac{(z_1^*)^{p_1}}{p_1!} \\ &= \left(\prod_{b>1} \sum_{\substack{p_b=0 \\ q_b=0}}^{\infty} \sum_{\lambda_b=0}^{\infty} \right) \left(\sum_{b>1} \lambda_b \right)! \left(\prod_{b>1} \frac{1}{\lambda_b!} \right) \prod_{b>1} \delta(\lambda_b - p_b - q_b) \frac{\lambda_b!}{p_b! q_b!} z_b^{p_b} \tilde{z}_b^{q_b} \\ &= \left(\prod_{b>1} \sum_{\lambda_b=0}^{\infty} \right) \left(\sum_{b>1} \lambda_b \right)! \prod_{b>1} \frac{1}{\lambda_b!} \left[\sum_{\substack{p_b=0 \\ q_b=0}}^{\infty} \delta(\lambda_b - p_b - q_b) \frac{\lambda_b!}{p_b! q_b!} z_b^{p_b} \tilde{z}_b^{q_b} \right] \end{aligned} \quad (\text{B.2.15})$$

The quantity inside the square bracket is of the form

$$\sum_{k_1, k_2=0}^{\infty} \delta(n - k_1 - k_2) \frac{n!}{k_1! k_2!} a^{k_1} b^{k_2} = (a + b)^n, \quad (\text{B.2.16})$$

so that we eventually have, relabelling $\lambda_b \rightarrow p_b$

$$\left(\prod_b \sum_{p_b=0}^{\infty} \right) \left(\sum_b p_b \right)! \left(\prod_{b>1} \frac{z_b^{p_b}}{p_b!} \right) \frac{(z_1^*)^{p_1}}{p_1!} = \left(\prod_{b>1} \sum_{p_b=0}^{\infty} \right) \left(\sum_{b>1} p_b \right)! \prod_{b>1} \frac{(z_b + \tilde{z}_b)^{p_b}}{p_b!} \quad (\text{B.2.17})$$

for the LHS of eq. (B.2.8).

Consider now the RHS of the same formula: it reads

$$\frac{1}{1 - \sum_{b>1} z_b - z_1^*} = \frac{1}{1 - \sum_{b>1} z_b - \sum_{c>1} \tilde{z}_c} = \frac{1}{1 - \sum_{b>1} (z_b + \tilde{z}_b)} \quad (\text{B.2.18})$$

Equating the right hand sides of the last two equations we then get

$$\left(\prod_{b>1} \sum_{p_b=0}^{\infty} \right) \left(\sum_{b>1} p_b \right)! \prod_{b>1} \frac{(z_b + \tilde{z}_b)^{p_b}}{p_b!} = \frac{1}{1 - \sum_{b>1} (z_b + \tilde{z}_b)} \quad (\text{B.2.19})$$

Using the substitutions in (B.2.9) and defining the new quantity $\hat{x}_{ba} \equiv x_{ba} + \tilde{x}_{ba}$ we immediately obtain

$$z_b + \tilde{z}_b \rightarrow \frac{z_b x_{ba} z_a^{-1}}{1 - z_a^{-1} \bar{t}_a} + \frac{z_b \tilde{x}_{ba} z_a^{-1}}{1 - z_a^{-1} \bar{t}_a} = \frac{z_b (x_{ba} + \tilde{x}_{ba}) z_a^{-1}}{1 - z_a^{-1} \bar{t}_a} \equiv \frac{z_b \hat{x}_{ba} z_a^{-1}}{1 - z_a^{-1} \bar{t}_a} \quad (\text{B.2.20})$$

so that eq. (B.2.19) becomes

$$\begin{aligned} & \left(\prod_{b>1} \sum_{p_{ba}=0}^{\infty} \right) \left(\sum_{b>1} p_{ba} \right)! \prod_{b>1} \frac{1}{p_{ba}!} \left(\frac{z_b \hat{x}_{ba} z_a^{-1}}{1 - z_a^{-1} \bar{t}_a} \right)^{p_{ba}} \\ &= \frac{1 - z_a^{-1} \bar{t}_a}{1 - z_a^{-1} \left(\bar{t}_a + \sum_{b>1} z_b \hat{x}_{ba} \right)}, \quad a \neq 1 \end{aligned} \quad (\text{B.2.21})$$

This is exactly the equation in (B.1.39) with the substitution $x_{ba} \rightarrow \hat{x}_{ba}$ and the removal of the first node. We have already proven such an equality in appendix B.1.2, where we have also obtained the set of constraints in (B.2.4). This means that the constraints coming from the convergence of the sums on the LHS of (B.2.21) can be described by the intersection of the set

$$\begin{aligned} \hat{\mathcal{K}}_a = & \left\{ z_a \in \mathbb{C} \text{ s.t. } |z_a| > \left| \frac{\bar{t}_a + \sum_{b \neq a, 1} z_b \hat{x}_{ba}}{1 - \hat{x}_{aa}} \right| \right\} \\ & \bigcap_{c \neq a} \left\{ z_c \in \mathbb{C} \text{ s.t. } |z_c| < \left| \frac{z_c - \left(\bar{t}_a + \sum_{b \neq c, 1} z_b \hat{x}_{ba} \right)}{\hat{x}_{ca}} \right| \right\}, \quad a \neq 1 \end{aligned} \quad (\text{B.2.22})$$

with the set of $\cup_{a>1} \{z_a\}$ satisfying the absolute convergence condition

$$\left(\prod_{b>1} \sum_{p_{ba}=0}^{\infty} \right) \left(\sum_{b>1} p_{ba} \right)! \prod_{b>1} \frac{1}{p_{ba}!} \left| \frac{z_b \hat{x}_{ba} z_a^{-1}}{1 - z_a^{-1} \bar{t}_a} \right|^{p_{ba}} < \infty, \quad a \neq 1 \quad (\text{B.2.23})$$

We stress once again that the former includes the latter. Such an intersection gives us a prescription on which poles to include/exclude after one integration has been done: in complete analogy to the situation discussed at the beginning of this section, we find that only the z_a pole coming from the I_a term in the integrand of (B.2.1) has to be picked up, $\forall a \neq 1$. The steps presented here are trivially generalisable, and they can be redone in the exact same way integration after integration. We can then say that, *at any level of integration*, only the z_a pole in the I_a factor has to be enclosed by \mathcal{C}_a in (B.2.1). This is our pole prescription to perform integrals.

B.3 Three node unflavoured quiver example

In this section we will provide an explicit example of application of the formulae presented in section 2.3 to the three node unflavoured case. Let us start by writing z_1^* , z_2^* and z_3^* . According

to eq. (2.3.9), the equation for $z_1^*(z_2, z_3; \vec{x})$ is obtained by solving for z_1 the equation

$$I_1^{-1}(z_1, z_2, z_3; \vec{x}) = z_1 - \sum_{b=1}^3 z_b x_{b,1} = 0 \quad (\text{B.3.1})$$

that gives

$$z_1^*(z_2, z_3; \vec{x}) = \sum_{i>1} z_i \frac{x_{i,1}}{1 - x_{1,1}} \quad (\text{B.3.2})$$

From (2.3.10) we then have

$$a_{i,1} = \frac{x_{i,1}}{1 - x_{1,1}} \quad (\text{B.3.3})$$

We now turn to $z_2^*(z_3; \vec{x})$, which is obtained by solving for z_2 the equation

$$I_2^{-1}(z_1^*, z_2, z_3) = z_2 - \sum_{b>1}^3 z_b x_{b,2} - z_1^* x_{1,2} = 0 \quad (\text{B.3.4})$$

Using (B.3.2) we get

$$z_2^*(z_3; \vec{x}) = \sum_{i>2} z_i \frac{(x_{i,1} x_{1,2} + x_{i,2}(1 - x_{1,1}))}{(1 - x_{1,1})(1 - x_{2,2}) - x_{1,2} x_{2,1}} \quad (\text{B.3.5})$$

so that

$$a_{i,2} = \frac{(x_{i,1} x_{1,2} + x_{i,2}(1 - x_{1,1}))}{(1 - x_{1,1})(1 - x_{2,2}) - x_{1,2} x_{2,1}} \quad (\text{B.3.6})$$

Finally, $I_3^{-1}(z_1^*, z_2^*, z_3) = 0$ is solved by $z_3^* = 0$. We can now write down the pole coefficients $\hat{a}_{i,p}^{[r]}$, which we will need in computing $F_0^{[3]}$. Following the definition given in (2.3.13), we have

$$\hat{a}_{i,p}^{[0]} = 0, \quad (\text{B.3.7})$$

$$\hat{a}_{i,p}^{[1]} = a_{i,p} + \sum_{\lambda=p+1}^1 a_{i,\lambda}^{[1]} a_{\lambda,p} = a_{i,p} \quad (\text{B.3.8})$$

and

$$\hat{a}_{i,p}^{[2]} = a_{i,p} + \sum_{\lambda=p+1}^2 a_{i,\lambda}^{[2]} a_{\lambda,p} = \begin{cases} a_{i,1} + \hat{a}_{i,2}^{[2]} a_{2,1} = a_{i,1} + a_{i,2} a_{2,1} & \text{if } p = 1 \\ a_{i,p} & \text{if } p > 1 \end{cases} \quad (\text{B.3.9})$$

Using eqs. (B.3.3) and (B.3.6), and noting that

$$1 - x_{1,1} = G_{[1]}, \quad (1 - x_{1,1})(1 - x_{2,2}) - x_{1,2} x_{2,1} = G_{[2]} \quad (\text{B.3.10})$$

we can also write

$$\hat{a}_{i,p}^{[2]} = \begin{cases} a_{i,1} + \frac{a_{i,2} x_{2,1}}{G_{[1]}} = \frac{x_{i,2} x_{2,1} + x_{i,1}(1 - x_{2,2})}{G_{[2]}} & \text{if } p = 1 \\ a_{i,p} & \text{if } p > 1 \end{cases} \quad (\text{B.3.11})$$

By using eq. (2.3.12),

$$z_j^{*[r]} = z_j^*(z_{r+1}, \dots, z_n; \vec{x}) = \sum_{i>r} z_i \hat{a}_{i,j}^{[r]}, \quad 1 \leq j \leq r \quad (\text{B.3.12})$$

we then obtain

$$z_1^{*[1]}(z_2, z_3, \vec{x}) = \sum_{i>1}^3 z_i \hat{a}_{i,1}^{[1]} = \sum_{i=2,3} \frac{z_i x_{i,1}}{G_{[1]}} \quad (\text{B.3.13})$$

and similarly

$$z_1^{*[2]}(z_3, \vec{x}) = \sum_{i>2}^3 z_i \hat{a}_{i,1}^{[2]} = z_3 \frac{x_{3,2} x_{2,1} + x_{3,1}(1 - x_{2,2})}{G_{[2]}}, \quad (\text{B.3.14})$$

$$z_2^{*[2]}(z_3, \vec{x}) = \sum_{i>2}^3 z_i \hat{a}_{i,2}^{[2]} = z_3 \frac{x_{3,1} x_{1,2} + x_{3,2}(1 - x_{1,1})}{G_{[2]}} \quad (\text{B.3.15})$$

Finally, we can compute $F_0^{[3]}$ using formula (2.3.23). We have

$$\begin{aligned} F_0^{[3]} &= \prod_{i=1}^3 H_i(\vec{x}) = \prod_{i=1}^3 \left(1 - x_{i,i} - \sum_{q=1}^{i-1} \hat{a}_{i,q}^{[i-1]} x_{q,i} \right)^{-1} \quad (\text{B.3.16}) \\ &= (1 - x_{1,1})^{-1} \left(1 - x_{2,2} - \hat{a}_{2,1}^{[1]} x_{1,2} \right)^{-1} \left(1 - x_{3,3} - \hat{a}_{3,1}^{[2]} x_{1,3} - \hat{a}_{3,2}^{[2]} x_{2,3} \right)^{-1} \\ &= (1 - x_{1,1})^{-1} \left(1 - x_{2,2} - a_{2,1} x_{1,2} \right)^{-1} \left(1 - x_{3,3} - a_{3,1} x_{1,3} - a_{3,2} \left(\frac{x_{2,1} x_{1,3}}{1 - x_{1,1}} + x_{2,3} \right) \right)^{-1} \end{aligned}$$

Using the equations for $a_{2,1}$ and $a_{3,1}$ defined in (B.3.3) and $a_{3,2}$ defined in (B.3.6), we get

$$\begin{aligned}
 F_0^{[3]} &= ((1 - x_{1,1})(1 - x_{2,2}) - x_{1,2}x_{2,1})^{-1} \left(1 - x_{3,3} - \frac{x_{1,3}x_{3,1}}{1 - x_{1,1}} \right. \\
 &\quad \left. - \frac{x_{3,1}x_{1,2} + x_{3,2}(1 - x_{1,1})}{(1 - x_{1,1})(1 - x_{2,2}) - x_{1,2}x_{2,1}} \left(\frac{x_{2,1}x_{1,3}}{1 - x_{1,1}} + x_{2,3} \right) \right)^{-1} \\
 &= \left(((1 - x_{1,1})(1 - x_{2,2}) - x_{1,2}x_{2,1}) \left(1 - x_{3,3} - \frac{x_{1,3}x_{3,1}}{1 - x_{1,1}} \right) \right. \\
 &\quad \left. - (x_{3,1}x_{1,2} + x_{3,2}(1 - x_{1,1})) \left(\frac{x_{2,1}x_{1,3}}{1 - x_{1,1}} + x_{2,3} \right) \right)^{-1} \\
 &= (1 - x_{1,1} - x_{2,2} - x_{3,3} - x_{1,2}x_{2,1} + x_{1,1}x_{2,2} - x_{1,3}x_{3,1} + x_{1,1}x_{3,3} - x_{2,3}x_{3,2} + x_{2,2}x_{3,3} \\
 &\quad - x_{1,1}x_{2,2}x_{3,3} + x_{1,1}x_{2,3}x_{3,2} + x_{2,2}x_{1,3}x_{3,1} + x_{3,3}x_{1,2}x_{2,1} - x_{1,2}x_{2,3}x_{3,1} - x_{1,3}x_{3,2}x_{2,1})^{-1}
 \end{aligned} \tag{B.3.17}$$

which concludes our computation.

B.3.1 Permutation formula

Let us now give an example of the application of formula (2.3.34) in this simple case of a three node unflavoured quiver. We have already computed the correct answer $F_0^{[3]}$ in the previous section, so we can explicitly check that (2.3.34) indeed reproduces the correct result. Let us call the three nodes of the quiver simply 1, 2 and 3. We can immediately write the simple loops $y_{\sigma^{(i)}}(\{x_{ab}\})$ using eq. (2.3.36):

$$\begin{aligned}
 y_{(1)}(\{x_{ab}\}) &= x_{11}, & y_{(2)}(\{x_{ab}\}) &= x_{22}, & y_{(3)}(\{x_{ab}\}) &= x_{33}, \\
 y_{(12)}(\{x_{ab}\}) &= x_{12}x_{21}, & y_{(13)}(\{x_{ab}\}) &= x_{13}x_{31}, & y_{(23)}(\{x_{ab}\}) &= x_{23}x_{32}, \\
 y_{(123)}(\{x_{ab}\}) &= x_{12}x_{23}x_{31} & y_{(132)}(\{x_{ab}\}) &= x_{13}x_{32}x_{21}
 \end{aligned} \tag{B.3.18}$$

From these quantities we can construct $y_{\sigma}(\{x_{ab}\})$, for every σ , by using the definition in eq. (2.3.35):

$$y_{\sigma}(\{x_{ab}\}) = (-1)^{c_{\sigma}} \prod_i y_{\sigma^{(i)}}(\{x_{ab}\}) \tag{B.3.19}$$

For example, if we had $\sigma = (12)(3)$, then

$$y_{(12)(3)}(\{x_{ab}\}) = (-1)^2 y_{(12)}(\{x_{ab}\}) y_{(3)}(\{x_{ab}\}) = x_{12}x_{21} x_{33} \tag{B.3.20}$$

the power 2 in the -1 comes from the fact that $\sigma = (12)(3)$ is a product of two cycles. Getting back to our three node quiver example, there are 7 non empty subsets that we can form out of

the set $\{1, 2, 3\}$, namely $\{1\}$, $\{2\}$, $\{3\}$, $\{12\}$, $\{13\}$, $\{23\}$, $\{123\}$. According to eq. (2.3.35) we then have

$$\sum_{\sigma \in \text{Sym}(\{1\})} y_{\sigma}(\{x_{ab}\}) = y_{(1)}(\{x_{ab}\}) = -x_{1,1}, \quad (\text{B.3.21a})$$

$$\sum_{\sigma \in \text{Sym}(\{2\})} y_{\sigma}(\{x_{ab}\}) = y_{(2)}(\{x_{ab}\}) = -x_{2,2}, \quad (\text{B.3.21b})$$

$$\sum_{\sigma \in \text{Sym}(\{3\})} y_{\sigma}(\{x_{ab}\}) = y_{(3)}(\{x_{ab}\}) = -x_{3,3}, \quad (\text{B.3.21c})$$

$$\sum_{\sigma \in \text{Sym}(\{12\})} y_{\sigma}(\{x_{ab}\}) = y_{(1)(2)}(\{x_{ab}\}) + y_{(12)}(\{x_{ab}\}) = x_{1,1}x_{2,2} - x_{1,2}x_{2,1}, \quad (\text{B.3.21d})$$

$$\sum_{\sigma \in \text{Sym}(\{13\})} y_{\sigma}(\{x_{ab}\}) = y_{(1)(3)}(\{x_{ab}\}) + y_{(13)}(\{x_{ab}\}) = x_{1,1}x_{3,3} - x_{1,3}x_{3,1}, \quad (\text{B.3.21e})$$

$$\sum_{\sigma \in \text{Sym}(\{23\})} y_{\sigma}(\{x_{ab}\}) = y_{(2)(3)}(\{x_{ab}\}) + y_{(23)}(\{x_{ab}\}) = x_{2,2}x_{3,3} - x_{2,3}x_{3,2}, \quad (\text{B.3.21f})$$

$$\begin{aligned} \sum_{\sigma \in \text{Sym}(\{123\})} y_{\sigma}(\{x_{ab}\}) &= y_{(1)(2)(3)}(\{x_{ab}\}) + y_{(12)(3)}(\{x_{ab}\}) + y_{(13)(2)}(\{x_{ab}\}) \\ &\quad + y_{(23)(1)}(\{x_{ab}\}) + y_{(123)}(\{x_{ab}\}) + y_{(132)}(\{x_{ab}\}) \\ &= -x_{1,1}x_{2,2}x_{3,3} + x_{1,2}x_{2,1}x_{3,3} + x_{1,3}x_{3,1}x_{2,2} \\ &\quad + x_{2,3}x_{3,2}x_{1,1} - x_{1,2}x_{2,3}x_{3,1} - x_{1,3}x_{3,2}x_{2,1} \end{aligned} \quad (\text{B.3.21g})$$

Summing all of the terms above we get

$$\begin{aligned} F_0^{[3]} &= (1 - x_{1,1} - x_{2,2} - x_{3,3} - x_{1,2}x_{2,1} + x_{1,1}x_{2,2} - x_{1,3}x_{3,1} + x_{1,1}x_{3,3} - x_{2,3}x_{3,2} + x_{2,2}x_{3,3} \\ &\quad - x_{1,1}x_{2,2}x_{3,3} + x_{1,1}x_{2,3}x_{3,2} + x_{2,2}x_{1,3}x_{3,1} + x_{3,3}x_{1,2}x_{2,1} - x_{1,2}x_{2,3}x_{3,1} - x_{1,3}x_{3,2}x_{2,1})^{-1} \end{aligned} \quad (\text{B.3.22})$$

in perfect agreement with (B.3.17).

B.3.2 Determinant formula

To conclude this section we now calculate $F_0^{[3]}$ yet another time, using the determinant formula:

$$F_0^{[n]} = \frac{1}{\det(1_n - X_n)}, \quad X_n|_{ij} = x_{ij}, \quad 1 \leq (i, j) \leq n \quad (\text{B.3.23})$$

This is the simplest way to calculate $F_0^{[3]}$. Since

$$X_3 = \begin{pmatrix} x_{11} & x_{12} & x_{13} \\ x_{21} & x_{22} & x_{23} \\ x_{31} & x_{32} & x_{33} \end{pmatrix} \quad (\text{B.3.24})$$

we have

$$F_0^{[3]} = \det^{-1}(1_3 - X_3) = \det^{-1} \begin{pmatrix} 1 - x_{11} & -x_{12} & -x_{13} \\ -x_{21} & 1 - x_{22} & -x_{23} \\ -x_{31} & -x_{32} & 1 - x_{33} \end{pmatrix} \quad (\text{B.3.25})$$

and so we immediately get

$$\begin{aligned} F_0^{[3]} = & (1 - x_{1,1} - x_{2,2} - x_{3,3} - x_{1,2}x_{2,1} + x_{1,1}x_{2,2} - x_{1,3}x_{3,1} + x_{1,1}x_{3,3} - x_{2,3}x_{3,2} + x_{2,2}x_{3,3} \\ & - x_{1,1}x_{2,2}x_{3,3} + x_{1,1}x_{2,3}x_{3,2} + x_{2,2}x_{1,3}x_{3,1} + x_{3,3}x_{1,2}x_{2,1} - x_{1,2}x_{2,3}x_{3,1} - x_{1,3}x_{3,2}x_{2,1})^{-1} \end{aligned} \quad (\text{B.3.26})$$

This is the same result we obtained using other computational methods earlier in this section.

B.4 An equation for the pole coefficients in term of paths

In this section we will prove eq. (2.3.25):

$$G_{[r]} \hat{a}_{p,q}^{[r]} = \sum_{t=0}^{r-1} \left(\sum_{\substack{i_1, i_2, \dots, i_t=1 \\ i_1 \neq i_2 \neq \dots \neq i_t \neq q}}^r G_{[r] \setminus \{q, \cup_{h=1}^t i_h\}} x_{p, i_1} x_{i_1, i_2} x_{i_2, i_3} \cdots x_{i_{t-1}, i_t} x_{i_t, q} \right) \quad (\text{B.4.1})$$

In the case $q = r$ this identity becomes particularly easy to prove, so let us start with this one.

From the definitions (2.3.13b) and (2.3.14) we get

$$\hat{a}_{i,r}^{[r]} = a_{i,r} = \frac{x_{i,r} + \sum_{\lambda=1}^{r-1} \hat{a}_{i,\lambda}^{[r-1]} x_{\lambda,r}}{1 - \left(x_{r,r} + \sum_{\lambda=1}^{r-1} \hat{a}_{r,\lambda}^{[r-1]} x_{\lambda,r} \right)} \quad (\text{B.4.2})$$

Now let us multiply and divide the far RHS above by $G_{[r-1]}$: recalling eqs. (2.3.30) and (2.3.32) we have

$$G_{[r-1]} \left[1 - \left(x_{r,r} + \sum_{\lambda=1}^{r-1} \hat{a}_{r,\lambda}^{[r-1]} x_{\lambda,r} \right) \right] = G_{[r-1]} \frac{G_{[r]}}{G_{[r-1]}} = G_{[r]} \quad (\text{B.4.3})$$

so that we can write eq. (B.4.2) as

$$G_{[r]} \hat{a}_{i,r}^{[r]} = G_{[r-1]} x_{i,r} + \sum_{\lambda \in [r-1]} G_{[r-1]} \hat{a}_{i,\lambda}^{[r-1]} x_{\lambda,r} \quad (\text{B.4.4})$$

Using the last equation we can prove eq. (B.4.1), for the $q = r$ case, by induction. The identity is trivial for 1 point: it just reads

$$G_{[1]} \hat{a}_{i,1}^{[1]} = G_{[1] \setminus \{1\}} x_{i,1} = G_{[0]} x_{i,1} \quad (\text{B.4.5})$$

for any $i > 1$, and since

$$G_{[0]} = 1, \quad G_{[1]} = 1 - x_{1,1}, \quad \hat{a}_{i,1}^{[1]} = a_{i,1} = \frac{x_{i,1}}{1 - x_{1,1}} \quad (\text{B.4.6})$$

eq. (B.4.5) is trivially satisfied. Let us now assume (B.4.1) is true for $r - 1$ points and let us show that it holds for r points too. We can then use (B.4.1) in the terms $G_{[r-1]} \hat{a}_{i,\lambda}^{[r-1]}$ of (B.4.4), to obtain

$$\begin{aligned} G_{[r]} \hat{a}_{i,r}^{[r]} &= G_{[r-1]} x_{i,r} \\ &+ \sum_{\lambda=1}^{r-1} \sum_{t=0}^{r-2} \sum_{\substack{i_1, i_2, \dots, i_t=1 \\ i_1 \neq i_2 \neq \dots \neq i_t \neq \lambda}}^{r-1} G_{[r-1] \setminus \{\lambda, \cup_{h=1}^t i_h\}} x_{i,i_1} x_{i_1,i_2} x_{i_2,i_3} \cdots x_{i_{t-1},i_t} x_{i_t,\lambda} x_{\lambda,r} \end{aligned} \quad (\text{B.4.7})$$

The next step is just a relabelling of the summation variables: first relabel $\lambda \rightarrow i_{t+1}$ and then $t \rightarrow t' = t + 1$ to get (dropping the prime symbol on t)

$$\begin{aligned} G_{[r]} \hat{a}_{i,r}^{[r]} &= G_{[r-1]} x_{i,r} \\ &+ \sum_{t=1}^{r-1} \sum_{\substack{i_1, i_2, \dots, i_t=1 \\ i_1 \neq i_2 \neq \dots \neq i_t}}^{r-1} G_{[r-1] \setminus \{\cup_{h=1}^t i_h\}} x_{i,i_1} x_{i_1,i_2} x_{i_2,i_3} \cdots x_{i_{t-1},i_t} x_{i_t,r} \end{aligned} \quad (\text{B.4.8})$$

Note that the first term on the RHS of the above equation is just the $t = 0$ component of the sum following it, so that

$$G_{[r]} \hat{a}_{i,r}^{[r]} = \sum_{t=0}^{r-1} \sum_{\substack{i_1, i_2, \dots, i_t=1 \\ i_1 \neq i_2 \neq \dots \neq i_t}}^{r-1} G_{[r-1] \setminus \{\cup_{h=1}^t i_h\}} x_{i,i_1} x_{i_1,i_2} x_{i_2,i_3} \cdots x_{i_{t-1},i_t} x_{i_t,r} \quad (\text{B.4.9})$$

which using $G_{[r-1]} = G_{[r] \setminus \{r\}}$ we can write as

$$G_{[r]} \hat{a}_{i,r}^{[r]} = \sum_{t=0}^{r-1} \left(\sum_{\substack{i_1, i_2, \dots, i_t=1 \\ i_1 \neq i_2 \neq \dots \neq i_t \neq r}}^r G_{[r] \setminus \{r, \cup_{h=1}^t i_h\}} x_{i,i_1} x_{i_1,i_2} x_{i_2,i_3} \cdots x_{i_{t-1},i_t} x_{i_t,r} \right) \quad (\text{B.4.10})$$

which is exactly eq. (B.4.1) for the case $q = r$. This observation concludes the first part of our proof.

The case $q \neq r$ could be potentially difficult to analyse, but we can overcome this complication using a trick: loosely speaking we will change the order of integration in (2.3.1), in such a way that the z_q variable, corresponding to the q node, will be integrated last. This will allow us to use the same induction process mentioned above, with trivial modifications. To begin with, we will argue that the order of integration does not affect the expression for the $\hat{a}_{i,j}^{[r]}$ coefficients defined in (2.3.12) and (2.3.13).

Consider again eq. (2.3.12):

$$z_j^{*[r]} = z_j^*(z_{r+1}, \dots, z_n; \vec{x}) = \sum_{i>r} z_i \hat{a}_{i,j}^{[r]} \quad (\text{B.4.11})$$

These are the equations for the poles of the z_j ($1 \leq j \leq r$) variables after we have integrated over z_1, z_2, \dots, z_r *in this order*, which in section 2.3 we called ‘natural ordering’. We labelled this *ordered* set as $\{z_1, z_2, \dots, z_r\} \equiv [r]$. Now consider integrating over the same set of variables z_1, z_2, \dots, z_r , but in a *different order*, which we call $\{z_{\sigma(1)}, z_{\sigma(2)}, \dots, z_{\sigma(r)}\} \equiv [r]_\sigma$. We then have, analogously to eq. (B.4.11),

$$z_{\sigma(j)}^{*[r]_\sigma} = z_{\sigma(j)}^*(z_{r+1}, \dots, z_n; \vec{x}) = \sum_{i>r} z_i \hat{a}_{i,\sigma(j)}^{[r]_\sigma} \quad (\text{B.4.12})$$

The key observation is that equations (B.4.11) and (B.4.12) have to contain the same set of equations. To see this, suppose that we want to calculate the z_{r+1} pole equation. Following section 2.3 we would have

$$(1 - x_{r+1,r+1})z_{r+1} = \sum_{b>r+1} z_b x_{b,r+1} + \sum_{i=1,\dots,r} z_i^{*[r]} x_{i,r+1}, \quad (\text{B.4.13})$$

if we use the $[r]$ set (the natural ordering), and

$$\begin{aligned} (1 - x_{r+1,r+1})z_{r+1} &= \sum_{b>r+1} z_b x_{b,r+1} + \sum_{i=1,\dots,r} z_{\sigma(i)}^{*[r]_\sigma} x_{\sigma(i),r+1} \\ &\equiv \sum_{b>r+1} z_b x_{b,r+1} + \sum_{i=1,\dots,r} z_i^{*[r]_\sigma} x_{i,r+1} \end{aligned} \quad (\text{B.4.14})$$

if we use the $[r]_\sigma$ set. Now take the difference of the two equations above to get

$$0 = \sum_{i=1,\dots,r} \left(z_i^{*[r]} - z_i^{*[r]_\sigma} \right) x_{i,r+1} \quad (\text{B.4.15})$$

Since $x_{i,r+1}$ does not appear inside $z_i^{*[r]}$ or $z_i^{*[r]_\sigma}$, for any i , the only way that the RHS of (B.4.15)

can be zero is that each term in the sum vanish on its own, so that

$$z_i^{*[r]} = z_i^{*[r]\sigma} \quad \forall i \in \{1, 2, \dots, r\} \quad (\text{B.4.16})$$

This indeed shows that (B.4.11) and (B.4.12) do contain the same set of equations. More precisely, since eq. (B.4.16) does not depend on a particular σ , we see that the order in which we compute integrals does not matter: after r integrations, whatever the order, the pole equations will be described by (B.4.11). Eq. (B.4.16) also implies that

$$\hat{a}_{i,q}^{[r]} = \hat{a}_{i,q}^{[r]\sigma} \quad (\text{B.4.17})$$

if $[r]$ and $[r]\sigma$ differ only by the order of their elements. This is what we need to prove the identity (B.4.1) for generic q . The proof will be based upon a comparison between \hat{a} coefficients computed in two different orderings.

Let us then choose the ordering $[r]_{\sigma_q} = \{z_1, z_2, \dots, z_{q-1}, z_{q+1}, \dots, z_r, z_q\}$, which we will just call $[r]_q$ for notational purposes. From (B.4.17) we have then

$$\hat{a}_{i,q}^{[r]} = \hat{a}_{i,q}^{[r]_q} = \frac{x_{i,q} + \sum_{\lambda \in [r-1]_q} \hat{a}_{i,\lambda}^{[r-1]_q} x_{\lambda,q}}{1 - \left(x_{q,q} + \sum_{\lambda \in [r-1]_q} \hat{a}_{q,\lambda}^{[r-1]_q} x_{\lambda,q} \right)} \quad (\text{B.4.18})$$

in which the last equality follows from (2.3.14): with the ordering $[r]_q$, z_q is in fact the last variable to be integrated over, so that it plays the role of the starting point (2.3.13b) in the recursion relation (2.3.13a). We are therefore in the same configuration discussed at the beginning of this section, where the right lower index of \hat{a} corresponds to the last one in the ordering $[r]_q$: we can therefore redo the steps (B.4.2) - (B.4.10), with trivial modifications, to obtain

$$G_{[r]} \hat{a}_{i,q}^{[r]} = G_{[r]} \hat{a}_{i,q}^{[r]_q} = \sum_{t=0}^{r-1} \left(\sum_{\substack{i_1, i_2, \dots, i_t=1 \\ i_1 \neq i_2 \neq \dots \neq i_t \neq q}}^r G_{[r] \setminus \{q, \cup_{h=1}^t i_h\}} x_{i,i_1} x_{i_1,i_2} x_{i_2,i_3} \cdots x_{i_{t-1},i_t} x_{i_t,q} \right) \quad (\text{B.4.19})$$

Eq. (B.4.1) is then proved.

B.5 The building block $F_0^{[n]}$ and closed string word counting: Examples

Let us consider the 2-node case. We will verify that the coefficients in the expansion of $F_0^{[2]}$ count words made from letters corresponding to simple loops in the 2-node quiver, with one edge for every specified start and end point. Thus there are letters $\hat{y}_1, \hat{y}_2, \hat{y}_{12}$. We require that letters corresponding to loops which do not share a node commute. Thus here we have $\hat{y}_1 \hat{y}_2 = \hat{y}_2 \hat{y}_1$. It

is useful to define

$$y_1 \equiv x_{11}, \quad y_2 \equiv x_{22}, \quad y_{12} \equiv x_{12}x_{21} \quad (\text{B.5.1})$$

together with

$$\begin{aligned} F_0^{[2]} &= \frac{1}{1 - y_1 - y_2 - y_{12} + y_1 y_2} = \frac{1}{(1 - y_1)(1 - y_2) - y_{12}} \\ &= \frac{1}{(1 - y_1)(1 - y_2)} \frac{1}{1 - \frac{y_{12}}{(1 - y_1)(1 - y_2)}} \end{aligned} \quad (\text{B.5.2})$$

Expanding this we get

$$\begin{aligned} F_0^{[2]} &= \sum_{n_1, n_2=0}^{\infty} y_1^{n_1} y_2^{n_2} \sum_{m=0}^{\infty} \left(\frac{y_{12}}{(1 - y_1)(1 - y_2)} \right)^m \\ &= \sum_{n_1, n_2=0}^{\infty} \sum_{m=0}^{\infty} \sum_{k_1, k_2=0}^{\infty} y_1^{n_1} y_2^{n_2} y^m y_1^{k_1} y_2^{k_2} \frac{(m + k_1 - 1)! (m + k_2 - 1)!}{k_1! (m - 1)! k_2! (m - 1)!} \end{aligned} \quad (\text{B.5.3})$$

and defining $N_1 = n_1 + k_1$ and $N_2 = n_2 + k_2$ we can write

$$F_0^{[2]} = \sum_{N_1, N_2, m=0}^{\infty} y_1^{N_1} y_2^{N_2} y^m \sum_{k_1=0}^{N_1} \sum_{k_2=0}^{N_2} \frac{(m + k_1 - 1)! (m + k_2 - 1)!}{k_1! (m - 1)! k_2! (m - 1)!} \quad (\text{B.5.4})$$

Finally, using the identity

$$\sum_{k_1=0}^{N_1} \frac{(m + k_1 - 1)!}{k_1! (m - 1)!} = \frac{(m + N_1)!}{m! N_1!} = \sum_{k_1=0}^{N_1} \frac{(m)_{k_1}}{k_1!} \quad (\text{B.5.5})$$

the expansion of $F_0^{[2]}$ reads

$$F_0^{[2]} = \sum_{N_1, N_2, m=0}^{\infty} y_1^{N_1} y_2^{N_2} y^m \frac{(m + N_1)! (m + N_2)!}{m! N_1! m! N_2!} \quad (\text{B.5.6})$$

The coefficient counts the number of words made from letters $\hat{y}_1, \hat{y}_2, \hat{y}_{12}$, with the condition that $\hat{y}_1 \hat{y}_2 = \hat{y}_2 \hat{y}_1$. The words containing m copies of \hat{y}_{12} can be built by writing the \hat{y}_{12} letters out in a line, with spaces between them, and then inserting the N_1 \hat{y}_1 letters in any of the $m + 1$ slots. Now build a sequence of N_1 numbers, recording which slot the first \hat{y}_1 goes into, which the second goes into and so on. Each number in the sequence is something between 1 and $m + 1$. Such a sequence can be mapped to a state $e_{a_1} \otimes e_{a_2} \dots \otimes e_{a_{N_1}}$. Sequences related by the symmetrization procedure of shuffling around the N_1 factors correspond to same word, because what matters is what goes in the $m + 1$ slots, not the order in which the N_1 copies of x_{11} were put there. Thus the sequences are in one-one correspondence with a basis for the symmetric

tensors $Sym(V_{m+1}^{\otimes N_1})$. The dimension of this space is precisely

$$\dim\left(Sym(V_{m+1}^{\otimes N_1})\right) = \frac{(m+N_1)!}{m!N_1!} \quad (\text{B.5.7})$$

Then we can insert the \hat{y}_2 in the $m+1$ slots and we get the other factor. This proves that, in the 2-node case, the words in the language we defined are counted by the $F_0^{[2]}$ -function.

Let us now turn to the three node case. Let us define

$$y_i \equiv x_{ii}, \quad y_{ij} \equiv x_{ij}x_{ji}, \quad y_{ijk} \equiv x_{ij}x_{jk}x_{ki} \quad (\text{B.5.8})$$

In this case

$$\begin{aligned} F_0^{[3]} &= (1-y_1)^{-1}(1-y_2)^{-1}(1-y_3)^{-1} \left[1 - \frac{y_{12}}{(1-y_1)(1-y_2)} - \frac{y_{13}}{(1-y_1)(1-y_3)} \right. \\ &\quad \left. - \frac{y_{23}}{(1-y_2)(1-y_3)} - \frac{y_{123}}{(1-y_1)(1-y_2)(1-y_3)} - \frac{y_{132}}{(1-y_1)(1-y_2)(1-y_3)} \right]^{-1} \\ &= \sum_{m_1, m_2, m_3=0}^{\infty} \sum_{p_1, \dots, p_5=0}^{\infty} y_1^{m_1} y_2^{m_2} y_3^{m_3} y_{12}^{p_1} y_{13}^{p_2} y_{23}^{p_3} y_{123}^{p_4} y_{132}^{p_5} \\ &\quad \times \frac{(p_1 + p_2 + \dots + p_5)!}{p_1!p_2!p_3!p_4!p_5!} \frac{1}{(1-y_1)^{p_1+p_2+p_4+p_5} (1-y_2)^{p_1+p_3+p_4+p_5} (1-y_3)^{p_2+p_3+p_4+p_5}} \\ &= \sum_{m_1, m_2, m_3=0}^{\infty} \sum_{p_1, \dots, p_5=0}^{\infty} y_1^{m_1} y_2^{m_2} y_3^{m_3} y_{12}^{p_1} y_{13}^{p_2} y_{23}^{p_3} y_{123}^{p_4} y_{132}^{p_5} \frac{(p_1 + p_2 + \dots + p_5)!}{p_1!p_2!p_3!p_4!p_5!} \\ &\quad \times \sum_{l_1, l_2, l_3=0}^{\infty} \frac{(p_1 + p_2 + p_4 + p_5)_{l_1}}{l_1!} \frac{(p_1 + p_3 + p_4 + p_5)_{l_2}}{l_2!} \frac{(p_2 + p_3 + p_4 + p_5)_{l_3}}{l_3!} y_1^{l_1} y_2^{l_2} y_3^{l_3} \\ &= \sum_{n_1, n_2, n_3=0}^{\infty} \sum_{p_1, \dots, p_5=0}^{\infty} y_1^{n_1} y_2^{n_2} y_3^{n_3} y_{12}^{p_1} y_{13}^{p_2} y_{23}^{p_3} y_{123}^{p_4} y_{132}^{p_5} \frac{(p_1 + p_2 + \dots + p_5)!}{p_1!p_2!p_3!p_4!p_5!} \quad (\text{B.5.9}) \\ &\quad \times \sum_{l_1=0}^{n_1} \sum_{l_2=0}^{n_2} \sum_{l_3=0}^{n_3} \frac{(p_1 + p_2 + p_4 + p_5)_{l_1}}{l_1!} \frac{(p_1 + p_3 + p_4 + p_5)_{l_2}}{l_2!} \frac{(p_2 + p_3 + p_4 + p_5)_{l_3}}{l_3!} y_1^{l_1} y_2^{l_2} y_3^{l_3} \end{aligned}$$

Finally we use the identity (B.5.5) above three times, to get

$$\begin{aligned} F_0^{[3]} &= \sum_{n_1, n_2, n_3=0}^{\infty} \sum_{p_1, \dots, p_5=0}^{\infty} y_1^{n_1} y_2^{n_2} y_3^{n_3} y_{12}^{p_1} y_{13}^{p_2} y_{23}^{p_3} y_{123}^{p_4} y_{132}^{p_5} \frac{(p_1 + p_2 + \dots + p_5)!}{p_1!p_2!p_3!p_4!p_5!} \quad (\text{B.5.10}) \\ &\quad \times \binom{p_1 + p_2 + p_4 + p_5 + n_1}{n_1} \binom{p_1 + p_3 + p_4 + p_5 + n_2}{n_2} \binom{p_2 + p_3 + p_4 + p_5}{n_3} \end{aligned}$$

For the closed string words in this case, there are letters $\hat{y}_i, \hat{y}_{ij}, \hat{y}_{ijk}$. The five letters $\hat{y}_{12}, \hat{y}_{13}, \hat{y}_{23}$,

$\hat{y}_{123}, \hat{y}_{132}$ do not commute with each other. $\hat{y}_1, \hat{y}_2, \hat{y}_3$ commute with each other. \hat{y}_1 commutes with \hat{y}_{23} . \hat{y}_2 commutes with \hat{y}_{13} , and \hat{y}_3 commutes with \hat{y}_{12} . We can build an arbitrary word by first fixing the numbers p_1, p_2, \dots, p_5 of the letters from the set $\{\hat{y}_{ij}, \hat{y}_{ijk}\}$. Then choose an order of these. The first multinomial factor

$$\frac{(p_1 + \dots + p_5)!}{p_1! \dots p_5!} \quad (\text{B.5.11})$$

gives the number of choices of this order. For each fixed order of these, we can insert the \hat{y}_i . Consider the insertion of the \hat{y}_1 and choose the number n_1 of them. We have $(p_1 + p_2 + p_4 + p_5 + 1)$ slots which specify where, relative to $\hat{y}_{12}, \hat{y}_{13}, \hat{y}_{123}, \hat{y}_{132}$, we are inserting these. As in the 2-node case, this is the dimension of $Sym^{n_1}(V_{p_1+p_2+p_4+p_5+1})$ which is given by

$$\binom{p_1 + p_2 + p_4 + p_5 + n_1}{n_1} \quad (\text{B.5.12})$$

The position relative to \hat{y}_{23} is immaterial in the word counting because \hat{y}_1 commutes with this. Hence p_3 does not appear in the above formula. In the same way, the insertion of the \hat{y}_2 and \hat{y}_3 account for the additional binomial factors. Since the \hat{y}_i commute with each other, the insertion of the \hat{y}_2 is insensitive to the previous insertion of the \hat{y}_1 . Likewise the insertion of the \hat{y}_3 is insensitive to the positions of the \hat{y}_1, \hat{y}_2 . Hence the word counting for specified $p_1, \dots, p_5, n_1, n_2, n_3$ has separate factors corresponding to insertions of $\hat{y}_1, \hat{y}_2, \hat{y}_3$ among the mutually non-commuting set $\{\hat{y}_{ij}, \hat{y}_{ijk}\}$.

These examples illustrate the general fact that the function $F_0^{[n]}(\{x_{ab}\})$ counts words made from letters corresponding to simple loops in the complete n -node quiver, with the condition that letters corresponding to loops without a shared node commute.

B.6 Deriving the flavoured $F^{[n]}$ function

In this section we will prove eq. (2.5.16):

$$F^{[n]} = F_0^{[n]} \exp\left(t_p \bar{t}_q \partial^{p,q} \log F_0^{[n]}\right) \quad (\text{B.6.1})$$

We will start from eq. (2.5.13):

$$F^{[n]} = \prod_{j=1}^n \left(\frac{\exp\left(\hat{a}_{0,j}^{[n]} t_j\right)}{1 - x_{j,j} - \sum_{i=1}^{j-1} \hat{a}_{j,i}^{[j-1]} x_{i,j}} \right) \quad (\text{B.6.2})$$

We already know that the denominator of (B.6.2) is

$$\prod_{l=1}^n \left(1 - x_{l,l} - \sum_{q=1}^{l-1} \hat{a}_{l,q}^{[l-1]} x_{q,l} \right) = \prod_{l=1}^n \frac{G^{[l]}}{G^{[l-1]}} = G^{[n]} \quad (\text{B.6.3})$$

so that we only need to work on its numerator, which is the exponentiation of the sum $\sum_{k=1}^n \hat{a}_{0,k}^{[n]} t_k$. As we did in section 2.5, let us now set $\bar{t}_p = x_{0,p}$ and $t_p = x_{p,0}$. We can multiply and divide (B.6.3) by $G^{[n]}$ to get

$$\sum_{k=1}^n \hat{a}_{0,k}^{[n]} x_{k,0} = \frac{1}{G^{[n]}} \sum_{k=1}^n G^{[n]} \hat{a}_{0,k}^{[n]} x_{k,0} \quad (\text{B.6.4})$$

Using eq. (2.3.25) on each of the terms $G^{[n]} \hat{a}_{0,k}^{[n]}$ in the sum above gives

$$\begin{aligned} \sum_{k=1}^n \hat{a}_{0,k}^{[n]} x_{k,0} &= \frac{1}{G^{[n]}} \sum_{k=1}^n x_{k,0} \sum_{t=0}^{n-1} \sum_{\substack{i_1, i_2, \dots, i_t=1 \\ i_1 \neq i_2 \neq \dots \neq i_t \neq k}}^n G^{[n] \setminus \{k, \cup_{h=1}^t i_h\}} x_{0, i_1} x_{i_1, i_2} x_{i_2, i_3} \cdots x_{i_{t-1}, i_t} x_{i_t, k} \\ &= \frac{1}{G^{[n]}} \sum_{k=1}^n \sum_{t=0}^{n-1} \sum_{\substack{i_1, i_2, \dots, i_t=1 \\ i_1 \neq i_2 \neq \dots \neq i_t \neq k}}^n G^{[n] \setminus \{k, \cup_{h=1}^t i_h\}} x_{0, i_1} x_{i_1, i_2} x_{i_2, i_3} \cdots x_{i_{t-1}, i_t} x_{i_t, k} x_{k, 0} \end{aligned} \quad (\text{B.6.5})$$

Consider the product of x_{ab} coefficients in the equation above,

$$x_{0, i_1} x_{i_1, i_2} x_{i_2, i_3} \cdots x_{i_{t-1}, i_t} x_{i_t, k} x_{k, 0} \quad (\text{B.6.6})$$

This can be interpreted as a path on the quiver starting from node 0, passing through t intermediate nodes i_h , $1 \leq h \leq t$, reaching node k and returning back at node 0. Crucially, since all the i_h nodes in this term do not ever take the value k (because of the summation ranges in (B.6.5)), such a path never intersects itself. Our aim now is to factor out the 0 node from such a term, rewriting it as a path starting from node k , passing through the same t intermediate nodes i_h and ending at node k again. We can achieve this goal by letting an appropriate derivative act on the string of x_{ab} coefficients in (B.6.6). Consider the identity

$$\begin{aligned} &x_{0, i_1} x_{i_1, i_2} x_{i_2, i_3} \cdots x_{i_{t-1}, i_t} x_{i_t, k} x_{k, 0} \\ &= x_{k, 0} \left(x_{0, i_1} \frac{\partial}{\partial x_{k, i_1}} + x_{0, k} \frac{\partial}{\partial x_{k, k}} \right) x_{k, i_1} x_{i_1, i_2} x_{i_2, i_3} \cdots x_{i_{t-1}, i_t} x_{i_t, k} \end{aligned} \quad (\text{B.6.7})$$

(no sum on k or i_1), where we added the term

$$\left(x_{0, i_1} \frac{\partial}{\partial x_{k, i_1}} + x_{0, k} \frac{\partial}{\partial x_{k, k}} \right) x_{k, i_1} = x_{0, i_1}, \quad i_1 \neq k \quad (\text{B.6.8})$$

The $\partial/\partial x_{k,k}$ derivative has been added in order to account for the $t = 0$ case (the one in which there are no intermediate steps in the path (B.6.6), which would just read $x_{0,k}x_{k,0}$): in this situation we would trivially get

$$x_{0,k}x_{k,0} = x_{k,0} \left(0 + x_{0,k} \frac{\partial}{\partial x_{k,k}} \right) x_{k,k} = x_{0,k}x_{k,0} \quad (\text{B.6.9})$$

so that the identity (B.6.7) holds for any $t \geq 0$. Note also that we can rewrite the same equation as

$$\begin{aligned} x_{0,i_1}x_{i_1,i_2}x_{i_2,i_3} \cdots x_{i_{t-1},i_t}x_{i_t,k}x_{k,0} &= \\ &= x_{k,0} \left(\sum_{\substack{p=1 \\ p \neq k}}^n x_{0,p} \frac{\partial}{\partial x_{k,p}} + x_{0,k} \frac{\partial}{\partial x_{k,k}} \right) x_{k,i_1}x_{i_1,i_2}x_{i_2,i_3} \cdots x_{i_{t-1},i_t}x_{i_t,k} \end{aligned} \quad (\text{B.6.10})$$

where the values that p can take ($\{1, 2, \dots, n\} \setminus \{k\}$) are the same ones on which i_1 runs in the sum in (B.6.5): all the i_1, i_2, \dots, i_t indices never take the value k , leaving x_{k,i_1} as the only variable on which the $\partial/\partial x_{k,p}$ derivative can act with nonzero result. We can then rewrite the identity (B.6.10) as

$$\begin{aligned} x_{0,i_1}x_{i_1,i_2}x_{i_2,i_3} \cdots x_{i_{t-1},i_t}x_{i_t,k}x_{k,0} &= \\ &= x_{k,0} \left(\sum_{p=1}^n x_{0,p} \frac{\partial}{\partial x_{k,p}} \right) x_{k,i_1}x_{i_1,i_2}x_{i_2,i_3} \cdots x_{i_{t-1},i_t}x_{i_t,k} \\ &= \sum_{p=1}^n t_k \bar{t}_p \partial^{k,p} x_{k,i_1}x_{i_1,i_2}x_{i_2,i_3} \cdots x_{i_{t-1},i_t}x_{i_t,k} \end{aligned} \quad (\text{B.6.11})$$

where in the last line we set $\frac{\partial}{\partial x_{k,q}} = \partial^{k,q}$ and used the original notation $x_{k,0} = t_k$, $x_{0,k} = \bar{t}_k$. At this stage, we successfully rewrote a our initial path $(0, i_1, i_2, \dots, i_t, k, 0)$ in terms of a suitable differential operator acting on a new path $(k, i_1, i_2, \dots, i_t, k)$.

Inserting eq. (B.6.11) into (B.6.5) gives

$$\begin{aligned} \sum_{k=1}^n \hat{a}_{0,k}^{[n]} x_{k,0} &= \\ &= \frac{1}{G_{[n]}} \sum_{k=1}^n \sum_{t=0}^{n-1} \sum_{\substack{i_1, i_2, \dots, i_t=1 \\ i_1 \neq i_2 \neq \dots \neq i_t \neq k}}^n G_{[n] \setminus \{k, \cup_{h=1}^t i_h\}} \sum_{p=1}^n y_k \bar{y}_p \partial^{k,p} x_{k,i_1}x_{i_1,i_2}x_{i_2,i_3} \cdots x_{i_{t-1},i_t}x_{i_t,k} \end{aligned} \quad (\text{B.6.12})$$

Note that $\partial_{k,p}$ can pass through $G_{[n] \setminus \{k, \cup_{h=1}^t i_h\}}$, since the latter does not contain the k -th point

(by construction). We can then write

$$\begin{aligned}
 & \sum_{k=1}^n \hat{a}_{0,k}^{[n]} x_{k,0} \\
 &= \frac{1}{G^{[n]}} \sum_{k,p=1}^n t_k \bar{t}_p \partial^{k,p} \sum_{t=0}^{n-1} \sum_{\substack{i_1, i_2, \dots, i_t=1 \\ i_1 \neq i_2 \neq \dots \neq i_t \neq k}}^n G^{[n] \setminus \{k, \cup_{h=1}^t i_h\}} x_{k, i_1} x_{i_1, i_2} x_{i_2, i_3} \cdots x_{i_{t-1}, i_t} x_{i_t, k} \quad (\text{B.6.13}) \\
 &= \frac{1}{G^{[n]}} \sum_{k,p=1}^n t_k \bar{t}_p \partial^{k,p} \left(\sum_{t=0}^{n-1} \sum_{\substack{i_1, i_2, \dots, i_t=1 \\ i_1 \neq i_2 \neq \dots \neq i_t \neq k}}^n G^{[n] \setminus \{k, \cup_{h=1}^t i_h\}} x_{k, i_1} x_{i_1, i_2} x_{i_2, i_3} \cdots x_{i_{t-1}, i_t} x_{i_t, k} - G^{[n] \setminus \{k\}} \right)
 \end{aligned}$$

where in the last line we added $G^{[n] \setminus \{k\}}$ under the derivative action: indeed $\partial_{k,p} G^{[n] \setminus \{k\}} = 0$, since $G^{[n] \setminus \{k\}}$ does not contain the k -th point, and thus any $x_{k,p} \forall p$. Note that the term in the round brackets of the equation above is just $-G^{[n]}$. The definition of $G^{[n]}$ we gave in eq. (2.3.29) reads

$$\begin{aligned}
 G^{[n]} &= G^{[n-1]} - \sum_{t=0}^{n-1} \sum_{\substack{i_1, i_2, \dots, i_t=1 \\ i_1 \neq i_2 \neq \dots \neq i_t}}^{n-1} G^{[n-1] \setminus \{\cup_{h=1}^t i_h\}} x_{n, i_1} x_{i_1, i_2} x_{i_2, i_3} \cdots x_{i_{t-1}, i_t} x_{i_t, n} \\
 &= G^{[n] \setminus \{n\}} - \sum_{t=0}^{n-1} \sum_{\substack{i_1, i_2, \dots, i_t=1 \\ i_1 \neq i_2 \neq \dots \neq i_t \neq n}}^n G^{[n] \setminus \{n, \cup_{h=1}^t i_h\}} x_{n, i_1} x_{i_1, i_2} x_{i_2, i_3} \cdots x_{i_{t-1}, i_t} x_{i_t, n} \quad (\text{B.6.14})
 \end{aligned}$$

but the same equation holds if, instead of n , we remove any integer $1 \leq k \leq n$ from the set $[n]$:

$$G^{[n]} = G^{[n] \setminus \{k\}} - \sum_{t=0}^{n-1} \sum_{\substack{i_1, i_2, \dots, i_t=1 \\ i_1 \neq i_2 \neq \dots \neq i_t \neq k}}^n G^{[n] \setminus \{k, \cup_{h=1}^t i_h\}} x_{k, i_1} x_{i_1, i_2} x_{i_2, i_3} \cdots x_{i_{t-1}, i_t} x_{i_t, k} \quad (\text{B.6.15})$$

Using (B.6.15) in (B.6.13) gives then

$$\sum_{k=1}^n x_{k,0} \hat{a}_{0,k}^{[n]} = -\frac{1}{G^{[n]}} \sum_{k,p=1}^n t_k \bar{t}_p \partial^{k,p} G^{[n]} = -\sum_{k,p=1}^n t_k \bar{t}_p \partial^{k,p} \log G^{[n]} \quad (\text{B.6.16})$$

so that we can write, for the numerator of F in (B.6.2)

$$\prod_{k=1}^n \exp \left(\hat{a}_{0,k}^{[n]} x_{k,0} \right) = \exp \left(\sum_{k=1}^n \hat{a}_{0,k}^{[n]} x_{k,0} \right) = \exp \left(-\sum_{k,p=1}^n t_k \bar{t}_p \partial^{k,p} \log G^{[n]} \right) \quad (\text{B.6.17})$$

This means that $F^{[n]}$ can be written as

$$F^{[n]} = \frac{\exp\left(-\sum_{k,p=1}^n t_k \bar{t}_p \partial^{k,p} \log G_{[n]}\right)}{G_{[n]}} \quad (\text{B.6.18})$$

or, using Einstein summation

$$F^{[n]} = \frac{\exp\left(-t_k \bar{t}_p \partial^{k,p} \log G_{[n]}\right)}{G_{[n]}} \quad (\text{B.6.19})$$

Recalling that $F_0^{[n]} = G_{[n]}^{-1}$, where F_0 is the generating function for the unflavoured case, we also have

$$F^{[n]} = F_0^{[n]} \exp\left(t_k \bar{t}_p \partial^{k,p} \log F_0^{[n]}\right) \quad (\text{B.6.20})$$

Furthermore, considering the chain of equalities

$$\frac{(-1)^{p+q} M_{p,q}}{\det(1_n - X_n)} = -\frac{1}{\det(1_n - X_n)} \partial^{p,q} \det(1_n - X_n) = \partial^{p,q} \log\left(\frac{1}{\det(1_n - X_n)}\right) \quad (\text{B.6.21})$$

we finally get to

$$F^{[n]} = F_0^{[n]} \exp\left(\sum_{p,q=1}^n t_p \bar{t}_q \frac{(-1)^{p+q} M_{p,q}}{\det(1_n - X_n)}\right) \quad (\text{B.6.22})$$

The latter is exactly (2.5.15).

Appendix C

Useful Formulae for the Permutation Centraliser Algebras

C.1 Analytic formula for the dimension of $\mathcal{M}(m, n)$

In this section we derive a formula for the dimension of $\mathcal{M}(m, n)$. This dimension is equal to the sum of Littlewood-Richardson coefficients

$$\text{Dim } \mathcal{M}(m, n) = \sum_{R_1 \vdash m, R_2 \vdash n} \sum_{R \vdash m+n} g(R_1, R_2, R) \quad (\text{C.1.1})$$

The sum of squares of the Littlewood-Richardson coefficients is the dimension of $\mathcal{A}(m, n)$ and has a simple 2-variable generating function. It is natural to ask if we can write a nice generating function for the dimension of $\mathcal{M}(m, n)$. While we have not been able to derive something of comparable simplicity, we will derive two interesting expressions (C.1.11) and (C.1.28) in terms of multi-variable polynomials.

Let T_p denote a conjugacy class of permutations with cycle structure determined by a vector (p_1, p_2, \dots) , i.e. permutations with p_i cycles of length i . Let now σ_p be an element in T_p . For $\sigma_p \in T_p$, it is known that [118]

$$\sum_R \chi_R(\sigma_p) = \prod_i \text{Coeff} \left(f_i(t_i), \frac{t_i^{p_i}}{p_i!} \right) \quad (\text{C.1.2})$$

where

$$f_i(t_i) = e^{\frac{(1-(-1)^i)}{2} t_i + \frac{i t_i^2}{2}} \quad (\text{C.1.3})$$

We can define

$$F(t_1, t_2, \dots) = \prod_i f_i(t_i) \quad (\text{C.1.4})$$

and write

$$\sum_R \chi_R(\sigma_p) = \text{Coeff} \left(F(t_1, t_2, \dots), \prod_i \frac{t_i^{p_i}}{p_i!} \right) \quad (\text{C.1.5})$$

It is also useful to define

$$\begin{aligned} \tilde{f}_i(t_i) &= f_i \left(\frac{t_i}{i} \right) \\ \tilde{F}(t_1, t_2, \dots) &= F \left(t_1, \frac{t_2}{2}, \frac{t_3}{3}, \dots \right) = F \left(\left\{ \frac{t_i}{i} \right\} \right) \\ &= \prod_{i:\text{odd}} e^{\frac{t_i}{i}} \prod_{i=1}^{\infty} e^{\frac{it_i^2}{2i}} \end{aligned} \quad (\text{C.1.6})$$

We can write the LR coefficients in terms of T_p 's as

$$\begin{aligned} g(R_1, R_2, R) &= \frac{1}{m!n!} \sum_{\sigma_1 \in S_m} \sum_{\sigma_2 \in S_n} \chi_{R_1}(\sigma_1) \chi_{R_2}(\sigma_2) \chi_R(\sigma_1 \circ \sigma_2) \\ &= \sum_{p \vdash m} \sum_{q \vdash n} \chi_{R_1}(T_p) \chi_{R_2}(T_q) \chi_R(T_p \circ T_q) \prod_i \frac{1}{i^{p_i+q_i} p_i! q_i!} \end{aligned} \quad (\text{C.1.7})$$

This uses the fact that the number of permutations in the class T_p is $n! / \prod_i i^{p_i} p_i!$. Now use the above formula for $\sum_R \chi_R(T_p)$, to obtain

$$\begin{aligned} &\sum_{R_1, R_2, R} g(R_1, R_2, R) \\ &= \sum_{p \vdash m} \sum_{q \vdash n} \prod_i \text{Coeff}(\tilde{f}_i(s_i), t_i^{p_i}) \text{Coeff}(\tilde{f}_i(t_i), t_i^{q_i}) \text{Coeff}(f_i(u_i), u_i^{p_i+q_i}) (p_i + q_i)! \\ &= \sum_{p \vdash m} \sum_{q \vdash n} \text{Coeff}(\tilde{F}(\vec{s}) \tilde{F}(\vec{t}) F(\vec{u}), \prod_i s_i^{p_i} t_i^{q_i} u_i^{p_i+q_i} (p_i + q_i)!^{-1}) \\ &= \sum_{p \vdash m} \sum_{q \vdash n} \text{Coeff}(\tilde{F}(\vec{s}) \tilde{F}(\vec{t}) \tilde{F}(\vec{u}), \prod_i s_i^{p_i} t_i^{q_i} u_i^{p_i+q_i}) i^{p_i+q_i} (p_i + q_i)! \end{aligned} \quad (\text{C.1.8})$$

It is useful to make the substitutions $s_i \rightarrow s^i z_i, t_i \rightarrow t^i z_i, u_i \rightarrow \bar{z}_i$ and to introduce a pairing ⁸

$$\langle z_j^k, \bar{z}_i^l \rangle = \delta_{ij} \delta_{kl} k! i^k \quad (\text{C.1.9})$$

With these substitutions define

$$\mathcal{F}(z_i, s) = \tilde{F}(t_i \rightarrow s^i z_i) \quad (\text{C.1.10})$$

⁸ Alternatively we can think about expectation values in a Fock space with $z_i \rightarrow a_i, \bar{z}_i \rightarrow a_i^\dagger$. This would allow us to write the subsequent formulae in terms of quantities in a 2D field theory. This perspective could be fruitful, but we will leave its exploration for the future

Then we can write

$$\text{Dim } (\mathcal{M}(m, n)) = \langle \text{Coeff } (\mathcal{F}(z_i, s)\mathcal{F}(z_i, t)\mathcal{F}(z_i, u = 1), s^m t^n) \rangle \quad (\text{C.1.11})$$

This has been checked for very simple cases, e.g. up to $(m, n) = (3, 3)$

C.1.1 Multi-variable polynomials

It is useful to isolate the multi-variable polynomials in the z_i variables at each order in the s, t variables. Let us introduce the quantities

$$\begin{aligned} \mathcal{A}(\vec{z}, s) &= \prod_i \exp \left[\frac{s^{2i} z_i^2}{2i} \right] \\ \mathcal{B}(\vec{z}, s) &= \prod_{i=1,3,\dots} \exp \left[\frac{s^i z_i}{i} \right] \end{aligned} \quad (\text{C.1.12})$$

It follows from previous formulae (C.1.6) and (C.1.10) that

$$\mathcal{F}(\vec{z}, s) = \mathcal{A}(\vec{z}, s)\mathcal{B}(\vec{z}, s) \quad (\text{C.1.13})$$

Introducing polynomials $\mathcal{F}_m(\vec{z})$ for each order in s we can rewrite the latter quantity as

$$\mathcal{F}(\vec{z}, s) = \sum_{m=0} \mathcal{F}_m(\vec{z}) s^m \quad (\text{C.1.14})$$

We will now write formulae for the coefficients of s^m in \mathcal{A} and \mathcal{B} . For $\mathcal{A}(\vec{z}, s)$ we derive

$$\mathcal{A}(\vec{z}, s) = \sum_{m=0}^{\infty} \mathcal{A}_{2m}(\vec{z}) s^{2m} = \sum_{p_1, p_2, \dots=0}^{\infty} \prod_{i=1}^{\infty} \frac{s^{2ip_i} z_i^{2ip_i}}{(2i)^{p_i} p_i!} \quad (\text{C.1.15})$$

so that

$$\mathcal{A}_{2m}(\vec{z}) = \sum_{p \vdash m} \frac{z_i^{2ip_i}}{(2i)^{p_i} p_i!} \quad (\text{C.1.16})$$

We can also define $\mathcal{A}_m(\vec{z})$ to be zero for odd m and equal to the above for the even values. It is useful to define the coefficients of $z_1^{2p_1} z_2^{4p_2} \dots z_i^{2ip_i}$ in the $\mathcal{A}(\vec{z}, s = 1)$ as

$$\mathcal{A}_{[p]} = \mathcal{A}_{[p_1, p_2, \dots]} = \prod_i \frac{1}{p_i! (2i)^{p_i}} \quad (\text{C.1.17})$$

so that we may write

$$\mathcal{A}_{2m} = \sum_{p \vdash m} \mathcal{A}_{[p]} \prod_{i=1}^{\infty} z_i^{2ip_i} \quad (\text{C.1.18})$$

Similarly, for $\mathcal{B}(\vec{z}, s)$ we obtain

$$\mathcal{B}(\vec{z}, s) = \prod_{i=0}^{\infty} \exp \left[\frac{s^{(2i+1)} z_{2i+1}}{(2i+1)} \right] \quad (\text{C.1.19})$$

and

$$\mathcal{B}_m(\vec{z}) = \sum_{\{p_1, p_3, \dots\} \vdash m} \prod_{i \text{ odd}} \frac{z_i^{ip_i}}{(i)^{p_i} p_i!} \quad (\text{C.1.20})$$

Therefore it is natural to define

$$\begin{aligned} \mathcal{B}_{[p_1, p_3, \dots]} &= \prod_i \frac{1}{i^{p_i} p_i!} \\ \mathcal{B}_m(\vec{z}) &= \sum_{p \vdash m} \mathcal{B}_{[p_1, p_3, \dots]} \prod_{i \text{ odd}} z_i^{ip_i} \end{aligned} \quad (\text{C.1.21})$$

Going back to (C.1.14) we get, using the formulae just derived

$$\begin{aligned} \mathcal{F}_m(\vec{z}) &= \sum_{k=0}^m \mathcal{A}_k(\vec{z}) \mathcal{B}_{m-k}(\vec{z}) = \sum_{k=0}^{\lfloor \frac{m}{2} \rfloor} \mathcal{A}_{2k}(\vec{z}) \mathcal{B}_{m-2k}(\vec{z}) \\ &= \sum_{k=0}^{\lfloor \frac{m}{2} \rfloor} \sum_{r \vdash k} \sum_{\substack{q \vdash m-2k \\ q \text{ odd}}} \mathcal{A}_{[r]} \mathcal{B}_{[q]} \prod_i z_i^{i(2r_i + q_i)} \end{aligned} \quad (\text{C.1.22})$$

Grouping terms with the same power of z_i we obtain

$$\mathcal{F}(\vec{z}, s = 1) = \sum_{[p_1, p_2, \dots]} \mathcal{F}_{[p_1, p_2, \dots]} \prod_i z_i^{ip_i} \quad (\text{C.1.23})$$

with

$$\mathcal{F}_{[p]} = \sum_{[r_1, r_2, \dots]} \sum_{[q_1, q_2, \dots]} \mathcal{A}_{[r_1, r_2, \dots]} \mathcal{B}_{[q_1, q_2, \dots]} \prod_{i \text{ even}} \delta(p_i, 2r_i) \prod_{i \text{ odd}} \delta(p_i, 2r_i + q_i) \quad (\text{C.1.24})$$

Note that the function $\mathcal{F}(\vec{z}, s)$ is closely related to the generating function for the cycle indices of S_n which is

$$\begin{aligned} \mathcal{Z}(\vec{z}, t) &= \exp \left[\sum_{i=1}^{\infty} \frac{t^i z_i}{i} \right] \\ \tilde{\mathcal{A}}(\vec{z}, s) &= (\mathcal{Z}(z_i \rightarrow z_i^2, s \rightarrow s^2))^{1/2} \\ \tilde{\mathcal{B}}(\vec{z}, s) &= (\mathcal{Z}(z_{2i+1} \rightarrow z_{2i+1}, z_{2i} \rightarrow 0))^{1/2} \end{aligned} \quad (\text{C.1.25})$$

We can work with the same function if we change the pairing. With the pairing

$$\langle z_i^{k_i}, z_j^{k_j} \rangle = \delta_{i,j} \delta_{k_i, k_j} k_i! i^{k_i} \quad (\text{C.1.26})$$

we can write the above formulae as

$$\text{Dim}(\mathcal{M}(m, n)) = \langle \mathcal{F}_m(\vec{z}) \mathcal{F}_n(\vec{z}), \mathcal{F}_{m+n}(\vec{z}) \rangle \quad (\text{C.1.27})$$

or, equivalently,

$$\begin{aligned} \text{Dim}(\mathcal{M}(m, n)) &= \sum_{p \vdash m} \sum_{q \vdash n} \mathcal{F}_{p_1, p_2, \dots} \mathcal{F}_{q_1, q_2, \dots} \mathcal{F}_{p_1 + p_2, q_1 + q_2, \dots} \prod_i i^{p_i + q_i} (p_i + q_i)! \\ &= \sum_{p \vdash m} \sum_{q \vdash n} \mathcal{F}_p \mathcal{F}_q \mathcal{F}_{p+q} \text{Sym}(p+q) \end{aligned} \quad (\text{C.1.28})$$

This is eq. (4.2.45).

C.2 LR rule for hook representations

Here we derive the LR decomposition rule for the tensor product of two hook representations. Let us consider three representations R , R_1 and R_2 of S_{m+n} , S_m and S_n respectively. The LR coefficient $g(R_1, R_2; R)$ gives the multiplicity with which the representation $R_1 \otimes R_2$ appear in the representation R upon its restriction to $S_m \times S_n$. There is a systematic procedure to obtain such coefficients [68], that we now briefly review. We take the Young diagrams corresponding to R_1 and R_2 , and we start by decorating the latter as follows. We write ‘1’ in all the boxes of the first row, ‘2’ in all the boxes of the second row and so on in a similar fashion until the last row. Then we proceed to move all the ‘1’ boxes from R_2 to R_1 , ensuring that that we produce legal Young diagrams and no two copies of ‘1’ appear in the same column. We then move the ‘2’ boxes following the same rules, and so on. In doing so, we also require a *reading condition*. At any step, reading from right to left along the first row and then subsequent rows, the number of ‘1’ boxes must be greater or equal to the number of ‘2’ boxes. Similarly, the number of ‘2’ boxes must be greater or equal to the number of ‘3’ boxes, and so on.

At the end of this procedure we are left with a collection of Young diagrams, made with $m+n$ boxes. If two or more of the resulting diagrams are identical (that is, they not only match in shape but also in the numbering of their boxes), we only retain one of them. Otherwise, if k diagrams R appear with the same shape but different numbering, we can say that $g(R_1, R_2; R) = k$. These will be the prescriptions that we will follow to derive our LR formula.

We specify any representation R by the sequence of pairs of integers $R = ((a_1, b_1), (a_2, b_2), \dots, (a_d, b_d))$. In a Young diagram interpretation, a_j ($1 \leq j \leq d$) is the number of boxes to the right of the j -th diagonal box, and b_j is the number of boxes below the j -th diagonal box. We refer to d as the ‘depth’ of the representation R . Hooks therefore are representations of depth

1. Schematically, in this appendix we will obtain the RHS of

$$(k_1, l_1) \otimes (k_2, l_2) = \bigoplus ((a_1, b_1), (a_2, b_2)) \tag{C.2.1}$$

In our derivation we imagine to keep the first hook fixed, and to add to it boxes coming from the second diagram. In doing so we are careful to follow the LR prescription. The boxes of the second diagram are decorated by a ‘1’ or a ‘v’, depending whether they come from the first row of the diagram or not. The tensor product $(k_1, l_1) \otimes (k_2, l_2)$ will decompose into a direct sum of a varying number of depth 2 representation and precisely two hooks (regardless of the actual value of $k_{1,2}, l_{1,2}$). These hooks are

$$\begin{aligned} \text{Hook 1: } & (k_1 + k_2 + 1, l_1 + l_2) \\ \text{Hook 2: } & (k_1 + k_2, l_1 + l_2 + 1) \end{aligned} \tag{C.2.2}$$

Notice that we can rewrite them using the notation we use for the depth two diagram as

$$\text{Hook 1: } ((k_1 + k_2 + 1, l_1 + l_2), (0, -1)) \tag{C.2.3}$$

$$\text{Hook 2: } ((k_1 + k_2, l_1 + l_2 + 1), (-1, 0)) \tag{C.2.4}$$

This notation will be helpful at a later stage.

We now turn to the depth two representations. We proceed systematically, grouping them into four categories according to the two yes/no questions:

- 1) Is there a $\boxed{1}$ in the first column of the resulting diagram?
- 2) Is there a \boxed{v} in the first row of the inner hook of the resulting diagram?

We now analyse these four possibilities.

C.2.1 (Y,Y) case

The diagrams in this class are of the form

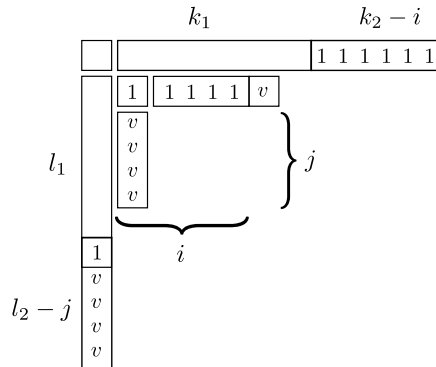

Figure 46: (Y,Y) case

C.2.3 (N,N) case

The depth two diagrams in this class are of the form

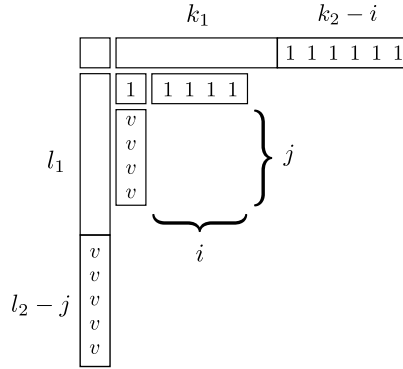

Figure 48: (N,N) case

They can be described by the expression

$$(N, N) : \quad ((k_1 + k_2 - i, l_1 + l_2 - j), (i, j)) \quad (\text{C.2.9})$$

with the boundaries

$$\begin{aligned} 0 \leq i \leq \min(k_1 - 1, k_2) \\ 0 \leq j \leq \min(l_1 - 1, l_2) \end{aligned} \quad (\text{C.2.10})$$

C.2.4 (N,Y) case

The diagrams in this class are of the form

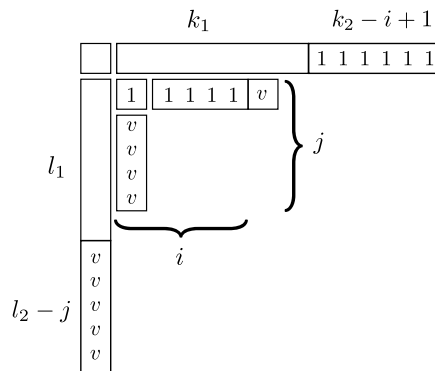

Figure 49: (N,Y) case

These can be described by the equation

$$(N, Y) : \quad ((k_1 + k_2 - i + 1, l_1 + l_2 - j), (i, j - 1)) \quad (\text{C.2.11})$$

The boundary for i is

$$0 \leq i \leq \min(k_1, k_2) \tag{C.2.12}$$

The upper bound is k_2 and not $k_2 + 1$ because we cannot remove all the $\boxed{1}$ from the first row, as the rightmost box in the second row has to be a \boxed{v} type box. In this way, we are enforcing the LR reading condition. On the other hand, the boundary for j is

$$1 \leq j \leq \min(l_1, l_2) \tag{C.2.13}$$

The lower bound is a 1 as by construction there has to be a \boxed{v} box in the first row of the inner hook.

C.2.5 A summary

These four cases comprise all possible valid depth two diagrams. Summarising our result, we have

- **(Y, Y) case:** $((k_1 + k_2 - i, l_1 + l_2 - j), (i, j))$

$$0 \leq i \leq \min(k_1, k_2 - 1)$$

$$0 \leq j \leq \min(l_1, l_2 - 1) \tag{C.2.14}$$

- **(Y, N) case:** $((k_1 + k_2 - i, l_1 + l_2 - j + 1), (i - 1, j))$

$$1 \leq i \leq \min(k_1, k_2)$$

$$0 \leq j \leq \min(l_1, l_2) \tag{C.2.15}$$

- **(N, N) case:** $((k_1 + k_2 - i, l_1 + l_2 - j), (i, j))$

$$0 \leq i \leq \min(k_1 - 1, k_2)$$

$$0 \leq j \leq \min(l_1 - 1, l_2) \tag{C.2.16}$$

$$\begin{aligned}
 \bullet \quad (N, Y) \text{ case:} \quad & ((k_1 + k_2 - i + 1, l_1 + l_2 - j), (i, j - 1)) \\
 & 0 \leq i \leq \min(k_1, k_2) \\
 & 1 \leq j \leq \min(l_1, l_2)
 \end{aligned} \tag{C.2.17}$$

We now introduce the boolean parameters

$$\epsilon_1 = \begin{cases} 0 & \text{If the answer to the first question is **no**} \\ 1 & \text{If the answer to the first question is **yes**} \end{cases} \tag{C.2.18}$$

and

$$\epsilon_2 = \begin{cases} 0 & \text{If the answer to the second question is **no**} \\ 1 & \text{If the answer to the second question is **yes**} \end{cases} \tag{C.2.19}$$

With this notation we can compactly rewrite (C.2.14) - (C.2.17) as

$$((k_1 + k_2 - i + \bar{\epsilon}_1 \epsilon_2, l_1 + l_2 - j + \epsilon_1 \bar{\epsilon}_2), (i - \epsilon_1 \bar{\epsilon}_2, j - \bar{\epsilon}_1 \epsilon_2)) \tag{C.2.20}$$

where the sign $\bar{}$ denotes the logical negation of a boolean variable, so that $\bar{\epsilon}_{1,2} = 1 - \epsilon_{1,2}$. In this notation, i and j have the boundaries

$$\begin{aligned}
 \epsilon_1 \bar{\epsilon}_2 \leq i \leq \min(k_1 - \bar{\epsilon}_1 \bar{\epsilon}_2, k_2 - \epsilon_1 \epsilon_2) \\
 \bar{\epsilon}_1 \epsilon_2 \leq j \leq \min(l_1 - \bar{\epsilon}_1 \bar{\epsilon}_2, l_2 - \epsilon_1 \epsilon_2)
 \end{aligned} \tag{C.2.21}$$

By denoting $h_1 = (k_1, l_1)$ and $h_2 = (k_2, l_2)$, together with $R = ((a_1, b_1), (a_2, b_2))$ we can then write

$$\begin{aligned}
 g(h_1, h_2; R) &= \delta_{k_1+k_2, a_1} \delta_{l_1+l_2+1, b_1} \delta_{-1, a_2} \delta_{0, b_2} + \delta_{k_1+k_2+1, a_1} \delta_{l_1+l_2, b_1} \delta_{0, a_2} \delta_{-1, b_2} \\
 &+ \sum_{\epsilon_1, \epsilon_2=0}^1 \sum_{i=\epsilon_1 \bar{\epsilon}_2}^{\min(k_1 - \bar{\epsilon}_1 \bar{\epsilon}_2, k_2 - \epsilon_1 \epsilon_2)} \sum_{j=\bar{\epsilon}_1 \epsilon_2}^{\min(l_1 - \bar{\epsilon}_1 \bar{\epsilon}_2, l_2 - \epsilon_1 \epsilon_2)} \delta_{k_1+k_2-i+\bar{\epsilon}_1 \epsilon_2, a_1} \delta_{l_1+l_2-j+\epsilon_1 \bar{\epsilon}_2, b_1} \delta_{i-\epsilon_1 \bar{\epsilon}_2, a_2} \delta_{j-\bar{\epsilon}_1 \epsilon_2, b_2}
 \end{aligned} \tag{C.2.22}$$

where we also added the two hooks in the depth two notation, (C.2.3) and (C.2.4). Explicitly, summing over the $\epsilon_{1,2}$ parameters, we get the lengthier expression

$$\begin{aligned}
g(h_1, h_2; R) &= \\
&= \delta_{k_1+k_2, a_1} \delta_{l_1+l_2+1, b_1} \delta_{-1, a_2} \delta_{0, b_2} + \sum_{i=1}^{\min(k_1, k_2)} \sum_{j=0}^{\min(l_1, l_2)} \delta_{k_1+k_2-i, a_1} \delta_{l_1+l_2-j+1, b_1} \delta_{i-1, a_2} \delta_{j, b_2} \\
&+ \delta_{k_1+k_2+1, a_1} \delta_{l_1+l_2, b_1} \delta_{0, a_2} \delta_{-1, b_2} + \sum_{i=0}^{\min(k_1, k_2)} \sum_{j=1}^{\min(l_1, l_2)} \delta_{k_1+k_2-i+1, a_1} \delta_{l_1+l_2-j, b_1} \delta_{i, a_2} \delta_{j-1, b_2} \\
&+ \left(\sum_{i=0}^{\min(k_1, k_2)-1} \sum_{j=0}^{\min(l_1, l_2)-1} + \sum_{i=0}^{\min(k_1-1, k_2)} \sum_{j=0}^{\min(l_1-1, l_2)} \right) \delta_{k_1+k_2-i, a_1} \delta_{l_1+l_2-j, b_1} \delta_{i, a_2} \delta_{j, b_2} \quad (\text{C.2.23})
\end{aligned}$$

From this equation it is clear that $g(h_1, h_2; R)$ can be either 0, 1 or 2. In particular, $g(h_1, h_2; R) = 2$ only if $R = ((k_1 + k_2 - i, l_1 + l_2 - j), (i, j))$ and $0 \leq i < \min(k_1, k_2)$, $0 \leq j < \min(l_1, l_2)$.

C.3 Deriving the two point correlator

In this Appendix we will derive eq. (4.4.9) from eq. (4.4.7). Let us start by considering the quantity

$$\chi_{R_1, R_2}^R \left(T_{\bar{1}, 1} T_{[m]}^{(X)} T_{[n]}^{(Y)} \right) \quad (\text{C.3.1})$$

where we remind the reader that R_1 , R_2 and R are irreps of S_m , S_n and S_{m+n} respectively. Let us define $T_2^{(X, Y)}$, $T_2^{(X)}$ and $T_2^{(Y)}$ as the sum of transpositions in S_{m+n} , S_m and S_n respectively. We can expand (C.3.1) as

$$\begin{aligned}
&\chi_{R_1, R_2}^R \left(T_{\bar{1}, 1} T_{[m]}^{(X)} T_{[n]}^{(Y)} \right) \\
&= \chi_{R_1, R_2}^R \left(T_2^{(X, Y)} T_{[m]}^{(X)} T_{[n]}^{(Y)} \right) - \chi_{R_1, R_2}^R \left(T_2^{(X)} T_{[m]}^{(X)} T_{[n]}^{(Y)} \right) - \chi_{R_1, R_2}^R \left(T_{[m]}^{(X)} T_2^{(Y)} T_{[n]}^{(Y)} \right) \\
&= g \frac{\chi_R(T_2^{(X, Y)})}{d_R} \chi_{R_1}(T_{[m]}^{(X)}) \chi_{R_2}(T_{[n]}^{(Y)}) - \frac{1}{g d_{R_1} d_{R_2}} \chi_{R_1, R_2}^R(T_2^{(X)}) \chi_{R_1, R_2}^R \left(T_{[m]}^{(X)} T_{[n]}^{(Y)} \right) + \\
&\quad - \frac{1}{g d_{R_1} d_{R_2}} \chi_{R_1, R_2}^R(T_2^{(Y)}) \chi_{R_1, R_2}^R \left(T_{[m]}^{(X)} T_{[n]}^{(Y)} \right) \\
&= g \frac{\chi_R(T_2^{(X, Y)})}{d_R} \chi_{R_1}(T_{[m]}^{(X)}) \chi_{R_2}(T_{[n]}^{(Y)}) - \frac{\chi_{R_1}(T_2^{(X)})}{d_{R_1}} \chi_{R_1, R_2}^R(T_{[m]}^{(X)} T_{[n]}^{(Y)}) + \\
&\quad - \frac{\chi_{R_2}(T_2^{(Y)})}{d_{R_2}} \chi_{R_1, R_2}^R(T_{[m]}^{(X)} T_{[n]}^{(Y)})
\end{aligned}$$

$$= g \chi_{R_1}(T_{[m]}^{(X)}) \chi_{R_2}(T_{[n]}^{(Y)}) \left[\frac{\chi_R(T_2^{(X,Y)})}{d_R} - \frac{\chi_{R_1}(T_2^{(X)})}{d_{R_1}} - \frac{\chi_{R_2}(T_2^{(Y)})}{d_{R_2}} \right] \quad (\text{C.3.2})$$

But now

$$\chi_{R_1}(T_{[m]}) = \begin{cases} (-1)^{c_{R_1}+1} (m-1)! & \text{if } R_1 \text{ is a hook representation} \\ 0 & \text{otherwise} \end{cases} \quad (\text{C.3.3})$$

where c_{R_1} is the number of boxes in the first column of the Young diagram associated with the representation R_1 . A similar equation holds for $\chi_{R_2}(T_{[n]})$. We then have

$$\begin{aligned} & \chi_{R_1, R_2}^R \left(T_{\bar{1},1} T_{[m]}^{(X)} T_{[n]}^{(Y)} \right) = \\ & = \begin{cases} (-1)^{c_{R_1}+c_{R_2}} g (m-1)!(n-1)! \left[\frac{\chi_R(T_2^{(X,Y)})}{d_R} - \frac{\chi_{R_1}(T_2^{(X)})}{d_{R_1}} - \frac{\chi_{R_2}(T_2^{(Y)})}{d_{R_2}} \right]; & R_1, R_2 \text{ hooks} \\ 0 & \text{otherwise} \end{cases} \end{aligned} \quad (\text{C.3.4})$$

this is eq. (4.4.8). Let us now restrict to the case in which both R_1, R_2 are hooks representations. We will denote these representations as $h_1 = R_1 = (k_1, l_1)$ and $h_2 = R_2 = (k_2, l_2)$. This also forces the representation R to be at most of depth two, as we derived in Appendix C.2. We now consider such a representation. With the notation given at the beginning of this section, $R = ((a_1, b_1), (a_2, b_2))$, it is immediate to write an equation for the normalised character $\frac{\chi_R(T_2)}{d_R}$

$$\frac{\chi_R(T_2)}{d_R} = \frac{1}{2} \sum_i r_i (r_i - 2i + 1) = a_1(a_1 + 1) + (a_2 + 2)(a_2 - 1) + \quad (\text{C.3.5})$$

$$\begin{aligned} & + 2 \sum_{i=3}^{b_2+2} (3 - 2i) + 2 \sum_{i=b_2+3}^{b_1+1} (1 - i) \\ & = \frac{1}{2} (a_1^2 + a_2^2 + a_1 + a_2) - \frac{1}{2} (b_1^2 + b_2^2 + b_1 + b_2) \\ & = \frac{1}{2} (a_1 + b_1 + 1)(a_1 - b_1) + \frac{1}{2} (a_2 + b_2 + 1)(a_2 - b_2) \end{aligned} \quad (\text{C.3.6})$$

We now need the equivalent of this formula for the depth one representations h_1 and h_2 , *i.e.* the hooks. Such an equation can be directly obtained by setting $(a_2, b_2) = (-1, 0)$ or $(a_2, b_2) = (0, -1)$ in (C.3.5). We can then write (C.3.4) as

$$\begin{aligned} & \chi_{h_1, h_2}^R \left(T_{\bar{1},1} T_{[m]}^{(X)} T_{[n]}^{(Y)} \right) = \frac{(-1)^{c_{h_1}+c_{h_2}}}{2} g (m-1)!(n-1)! \times \\ & \times \left[(a_1 + b_1 + 1)(a_1 - b_1) + (a_2 + b_2 + 1)(a_2 - b_2) + \right. \\ & \quad \left. - (k_1 + l_1 + 1)(k_1 - l_1) - (k_2 + l_2 + 1)(k_2 - l_2) \right] \end{aligned} \quad (\text{C.3.7})$$

where $R = ((a_1, b_1), (a_2, b_2))$ and $h_1 = (k_1, l_1), h_2 = (k_2, l_2)$.

The last piece we need is an equation for the $U(N)$ dimension of a depth two representation

$R = ((a_1, b_1), (a_2, b_2))$. It is straightforward to write

$$\text{Dim}_N(R) = \frac{(a_1 - a_2)(b_1 - b_2)}{(a_1 + b_2 + 1)(a_2 + b_1 + 1)} \binom{a_1 + b_1}{b_1} \binom{a_2 + b_2}{b_2} \binom{N + a_1}{a_1 + b_1 + 1} \binom{N + a_2}{a_2 + b_2 + 1} \quad (\text{C.3.8})$$

This equation reduces to its depth 1 equivalent by imposing $(a_2, b_2) = (-1, 0)$ or $(a_2, b_2) = (0, -1)$. It is also helpful to recall the dimension formula for a S_{l+k+1} hook representation (k, l) :

$$d_R = \binom{k+l}{k} \quad (\text{C.3.9})$$

Let us now consider eq. (4.4.7):

$$\langle \mathcal{O} \mathcal{O}^\dagger \rangle = \frac{1}{m!n!} \sum_{\substack{R_1 \vdash m \\ R_2 \vdash n}} \sum_{R \vdash m+n} \frac{1}{d_{R_1} d_{R_2} g} \text{Dim}_N(R) \left(\chi_{R_1, R_2}^R \left(T_{1,1}^R T_{[m]}^{(X)} T_{[n]}^{(Y)} \right) \right)^2 \quad (\text{C.3.10})$$

Inserting eq. (C.3.7), (C.3.8) and (C.3.9) into the above equation gives

$$\begin{aligned} & \langle \text{Tr}(X^m Y^n) \text{Tr}(X^m Y^n)^\dagger \rangle \\ &= \sum_{k_1, l_1=0}^m \sum_{k_2, l_2=0}^n \sum_{\substack{a_1, b_1=0 \\ a_2, b_2=0}}^{n+m} g \delta(k_1 + l_1 + 1 - m) \delta(k_2 + l_2 + 1 - n) F(a_1, b_1, a_2, b_2, k_1, l_1, k_2, l_2) \end{aligned} \quad (\text{C.3.11})$$

where we defined the function

$$\begin{aligned} F(a_1, b_1, a_2, b_2, k_1, l_1, k_2, l_2) &= \frac{k_1! k_2! l_1! l_2! (a_1 - a_2)(b_1 - b_2)}{4(a_1 + b_2 + 1)(a_2 + b_1 + 1)(k_1 + l_1 + 1)(k_2 + l_2 + 1)} \\ &\times \binom{a_1 + b_1}{b_1} \binom{a_2 + b_2}{b_2} \binom{N + a_1}{a_1 + b_1 + 1} \binom{N + a_2}{a_2 + b_2 + 1} \times \\ &\times ((a_1 + b_1 + 1)(a_1 - b_1) + (a_2 + b_2 + 1)(a_2 - b_2) + \\ &\quad - (k_1 + l_1 + 1)(k_1 - l_1) - (k_2 + l_2 + 1)(k_2 - l_2))^2 \end{aligned} \quad (\text{C.3.12})$$

Bibliography

- [1] P. Mattioli and S. Ramgoolam, *Quivers, Words and Fundamentals*, *JHEP* **03** (2015) 105, [[arXiv:1412.5991](#)].
- [2] P. Mattioli and S. Ramgoolam, *Permutation Centralizer Algebras and Multi-Matrix Invariants*, *Phys. Rev.* **D93** (2016), no. 6 065040, [[arXiv:1601.0608](#)].
- [3] P. Mattioli and S. Ramgoolam, *Gauge Invariants and Correlators in Flavoured Quiver Gauge Theories*, [arXiv:1603.0436](#).
- [4] G. Veneziano, *Construction of a crossing - symmetric, Regge behaved amplitude for linearly rising trajectories*, *Nuovo Cim.* **A57** (1968) 190–197.
- [5] M. B. Green and J. H. Schwarz, *Anomaly Cancellation in Supersymmetric D=10 Gauge Theory and Superstring Theory*, *Phys. Lett.* **B149** (1984) 117–122.
- [6] E. Witten, *String theory dynamics in various dimensions*, *Nucl. Phys.* **B443** (1995) 85–126, [[hep-th/9503124](#)].
- [7] J. Polchinski, *Dirichlet Branes and Ramond-Ramond charges*, *Phys. Rev. Lett.* **75** (1995) 4724–4727, [[hep-th/9510017](#)].
- [8] J. M. Maldacena, *The Large N limit of superconformal field theories and supergravity*, *Int. J. Theor. Phys.* **38** (1999) 1113–1133, [[hep-th/9711200](#)]. [Adv. Theor. Math. Phys.2,231(1998)].
- [9] E. Witten, *Anti-de Sitter space and holography*, *Adv. Theor. Math. Phys.* **2** (1998) 253–291, [[hep-th/9802150](#)].
- [10] S. S. Gubser, I. R. Klebanov, and A. M. Polyakov, *Gauge theory correlators from noncritical string theory*, *Phys. Lett.* **B428** (1998) 105–114, [[hep-th/9802109](#)].
- [11] V. Balasubramanian, D. Berenstein, B. Feng, and M.-x. Huang, *D-branes in Yang-Mills theory and emergent gauge symmetry*, *JHEP* **03** (2005) 006, [[hep-th/0411205](#)].
- [12] D. E. Berenstein, J. M. Maldacena, and H. S. Nastase, *Strings in flat space and pp waves from N=4 superYang-Mills*, *JHEP* **04** (2002) 013, [[hep-th/0202021](#)].

-
- [13] J. McGreevy, L. Susskind, and N. Toumbas, *Invasion of the giant gravitons from Anti-de Sitter space*, *JHEP* **06** (2000) 008, [[hep-th/0003075](#)].
- [14] R. C. Myers, *Dielectric branes*, *JHEP* **12** (1999) 022, [[hep-th/9910053](#)].
- [15] R. d. M. Koch and S. Ramgoolam, *From Matrix Models and Quantum Fields to Hurwitz Space and the absolute Galois Group*, [arXiv:1002.1634](#).
- [16] V. Balasubramanian, M. Berkooz, A. Naqvi, and M. J. Strassler, *Giant gravitons in conformal field theory*, *JHEP* **04** (2002) 034, [[hep-th/0107119](#)].
- [17] S. Corley, A. Jevicki, and S. Ramgoolam, *Exact correlators of giant gravitons from dual $N=4$ SYM theory*, *Adv.Theor.Math.Phys.* **5** (2002) 809–839, [[hep-th/0111222](#)].
- [18] S. Corley and S. Ramgoolam, *Finite factorization equations and sum rules for BPS correlators in $N=4$ SYM theory*, *Nucl.Phys.* **B641** (2002) 131–187, [[hep-th/0205221](#)].
- [19] J. M. Maldacena and A. Strominger, *AdS(3) black holes and a stringy exclusion principle*, *JHEP* **12** (1998) 005, [[hep-th/9804085](#)].
- [20] I. Bena and D. J. Smith, *Towards the solution to the giant graviton puzzle*, *Phys. Rev.* **D71** (2005) 025005, [[hep-th/0401173](#)].
- [21] V. Balasubramanian, M.-x. Huang, T. S. Levi, and A. Naqvi, *Open strings from $N=4$ superYang-Mills*, *JHEP* **08** (2002) 037, [[hep-th/0204196](#)].
- [22] R. de Mello Koch, J. Smolic, and M. Smolic, *Giant Gravitons - with Strings Attached (I)*, *JHEP* **06** (2007) 074, [[hep-th/0701066](#)].
- [23] R. de Mello Koch, J. Smolic, and M. Smolic, *Giant Gravitons - with Strings Attached (II)*, *JHEP* **09** (2007) 049, [[hep-th/0701067](#)].
- [24] D. Bekker, R. de Mello Koch, and M. Stephanou, *Giant Gravitons - with Strings Attached. III.*, *JHEP* **02** (2008) 029, [[arXiv:0710.5372](#)].
- [25] M. Bianchi, F. A. Dolan, P. J. Heslop, and H. Osborn, *$N=4$ superconformal characters and partition functions*, *Nucl. Phys.* **B767** (2007) 163–226, [[hep-th/0609179](#)].
- [26] J. Pasukonis and S. Ramgoolam, *Quivers as Calculators: Counting, Correlators and Riemann Surfaces*, *JHEP* **04** (2013) 094, [[arXiv:1301.1980](#)].
- [27] Y. Kimura and S. Ramgoolam, *Branes, anti-branes and brauer algebras in gauge-gravity duality*, *JHEP* **0711** (2007) 078, [[arXiv:0709.2158](#)].
- [28] T. W. Brown, P. Heslop, and S. Ramgoolam, *Diagonal multi-matrix correlators and BPS operators in $N=4$ SYM*, *JHEP* **0802** (2008) 030, [[arXiv:0711.0176](#)].
- [29] T. W. Brown, P. Heslop, and S. Ramgoolam, *Diagonal free field matrix correlators, global symmetries and giant gravitons*, *JHEP* **0904** (2009) 089, [[arXiv:0806.1911](#)].

-
- [30] R. Bhattacharyya, S. Collins, and R. d. M. Koch, *Exact Multi-Matrix Correlators*, *JHEP* **0803** (2008) 044, [[arXiv:0801.2061](#)].
- [31] S. Collins, *Restricted Schur Polynomials and Finite N Counting*, *Phys.Rev.* **D79** (2009) 026002, [[arXiv:0810.4217](#)].
- [32] R. de Mello Koch and S. Ramgoolam, *A double coset ansatz for integrability in AdS/CFT* , *JHEP* **06** (2012) 083, [[arXiv:1204.2153](#)].
- [33] W. Carlson, R. d. M. Koch, and H. Lin, *Nonplanar Integrability*, *JHEP* **03** (2011) 105, [[arXiv:1101.5404](#)].
- [34] R. d. M. Koch, B. A. E. Mohammed, and S. Smith, *Nonplanar Integrability: Beyond the $SU(2)$ Sector*, *Int. J. Mod. Phys.* **A26** (2011) 4553–4583, [[arXiv:1106.2483](#)].
- [35] R. d. M. Koch, M. Dessein, D. Giataganas, and C. Mathwin, *Giant Graviton Oscillators*, *JHEP* **10** (2011) 009, [[arXiv:1108.2761](#)].
- [36] R. de Mello Koch, R. Kreyfelt, and N. Nokwara, *Finite N Quiver Gauge Theory*, *Phys. Rev.* **D89** (2014), no. 12 126004, [[arXiv:1403.7592](#)].
- [37] P. Caputa, R. d. M. Koch, and P. Diaz, *Operators, Correlators and Free Fermions for $SO(N)$ and $Sp(N)$* , *JHEP* **06** (2013) 018, [[arXiv:1303.7252](#)].
- [38] R. de Mello Koch, B. A. E. Mohammed, J. Murugan, and A. Prinsloo, *Beyond the Planar Limit in ABJM*, *JHEP* **05** (2012) 037, [[arXiv:1202.4925](#)].
- [39] J. Pasukonis and S. Ramgoolam, *From counting to construction of BPS states in $N=4$ SYM*, *JHEP* **02** (2011) 078, [[arXiv:1010.1683](#)].
- [40] D. Berenstein, *Extremal chiral ring states in the AdS/CFT correspondence are described by free fermions for a generalized oscillator algebra*, *Phys. Rev.* **D92** (2015), no. 4 046006, [[arXiv:1504.0538](#)].
- [41] Y. Kimura, *Multi-matrix models and Noncommutative Frobenius algebras obtained from symmetric groups and Brauer algebras*, *Commun. Math. Phys.* **337** (2015), no. 1 1–40, [[arXiv:1403.6572](#)].
- [42] J. McGrane, S. Ramgoolam, and B. Wecht, *Chiral Ring Generating Functions & Branches of Moduli Space*, [arXiv:1507.0848](#).
- [43] O. Aharony, O. Bergman, D. L. Jafferis, and J. Maldacena, *$N=6$ superconformal Chern-Simons-matter theories, $M2$ -branes and their gravity duals*, *JHEP* **10** (2008) 091, [[arXiv:0806.1218](#)].
- [44] T. K. Dey, *Exact Large R -charge Correlators in ABJM Theory*, *JHEP* **1108** (2011) 066, [[arXiv:1105.0218](#)].

-
- [45] R. de Mello Koch, B. A. E. Mohammed, J. Murugan, and A. Prinsloo, *Beyond the Planar Limit in ABJM*, *JHEP* **1205** (2012) 037, [[arXiv:1202.4925](#)].
- [46] B. A. E. Mohammed, *Nonplanar Integrability and Parity in ABJ Theory*, *Int.J.Mod.Phys.* **A28** (2013) 1350043, [[arXiv:1207.6948](#)].
- [47] P. Caputa and B. A. E. Mohammed, *From Schurs to Giants in ABJ(M)*, *JHEP* **1301** (2013) 055, [[arXiv:1210.7705](#)].
- [48] M. R. Douglas and G. W. Moore, *D-branes, quivers, and ALE instantons*, [hep-th/9603167](#).
- [49] A. Karch and E. Katz, *Adding flavor to AdS / CFT*, *JHEP* **0206** (2002) 043, [[hep-th/0205236](#)].
- [50] J. Erdmenger and V. Filev, *Mesons from global Anti-de Sitter space*, *JHEP* **1101** (2011) 119, [[arXiv:1012.0496](#)].
- [51] D. Arnaudov, V. Filev, and R. Rashkov, *Flavours in global Klebanov-Witten background*, *JHEP* **1403** (2014) 023, [[arXiv:1312.7224](#)].
- [52] P. Ouyang, *Holomorphic D7 branes and flavored N=1 gauge theories*, *Nucl.Phys.* **B699** (2004) 207–225, [[hep-th/0311084](#)].
- [53] T. S. Levi and P. Ouyang, *Mesons and flavor on the conifold*, *Phys.Rev.* **D76** (2007) 105022, [[hep-th/0506021](#)].
- [54] Y. Kimura and S. Ramgoolam, *Enhanced symmetries of gauge theory and resolving the spectrum of local operators*, *Phys.Rev.* **D78** (2008) 126003, [[arXiv:0807.3696](#)].
- [55] Y. Kimura, *Correlation functions and representation bases in free N=4 Super Yang-Mills*, *Nucl. Phys.* **B865** (2012) 568–594, [[arXiv:1206.4844](#)].
- [56] R. de Mello Koch, B. A. E. Mohammed, J. Murugan, and A. Prinsloo, *Beyond the Planar Limit in ABJM*, *JHEP* **05** (2012) 037, [[arXiv:1202.4925](#)].
- [57] B. A. E. Mohammed, *Nonplanar Integrability and Parity in ABJ Theory*, *Int. J. Mod. Phys.* **A28** (2013) 1350043, [[arXiv:1207.6948](#)].
- [58] P. Caputa and B. A. E. Mohammed, *From Schurs to Giants in ABJ(M)*, *JHEP* **01** (2013) 055, [[arXiv:1210.7705](#)].
- [59] D. Berenstein, *Extremal chiral ring states in the AdS/CFT correspondence are described by free fermions for a generalized oscillator algebra*, *Phys. Rev.* **D92** (2015), no. 4 046006, [[arXiv:1504.0538](#)].
- [60] R. de Mello Koch, R. Kreyfelt, and S. Smith, *Heavy Operators in Superconformal Chern-Simons Theory*, *Phys. Rev.* **D90** (2014), no. 12 126009, [[arXiv:1410.0874](#)].

-
- [61] R. de Mello Koch, R. Kreyfelt, and N. Nokwara, *Finite N Quiver Gauge Theory*, *Phys. Rev.* **D89** (2014), no. 12 126004, [[arXiv:1403.7592](#)].
- [62] Y. Lozano, J. Murugan, and A. Prinsloo, *A giant graviton genealogy*, *JHEP* **08** (2013) 109, [[arXiv:1305.6932](#)].
- [63] P. Diaz, *Novel charges in CFT's*, *JHEP* **09** (2014) 031, [[arXiv:1406.7671](#)].
- [64] P. Cartier and D. Foata, *Problèmes combinatoires de commutation et réarrangements*. Springer-Verlag, Berlin, 1969.
- [65] C. Krattenthaler, *The theory of heaps and the cartier-foata monoid*, *Appendix of Commutation and Rearrangements* (2006) 63–73.
- [66] B. Sundborg, *Stringy gravity, interacting tensionless strings and massless higher spins*, *Nucl.Phys.Proc.Suppl.* **102** (2001) 113–119, [[hep-th/0103247](#)].
- [67] O. Aharony, J. Marsano, S. Minwalla, K. Papadodimas, and M. Van Raamsdonk, *The Hagedorn - deconfinement phase transition in weakly coupled large N gauge theories*, *Adv.Theor.Math.Phys.* **8** (2004) 603–696, [[hep-th/0310285](#)].
- [68] W. Fulton and J. Harris, *Representation Theory: A First Course*. Graduate Texts in Mathematics / Readings in Mathematics. Springer New York, 1991.
- [69] S. Ramgoolam, *Schur-Weyl duality as an instrument of Gauge-String duality*, *AIP Conf.Proc.* **1031** (2008) 255–265, [[arXiv:0804.2764](#)].
- [70] A. Terras, *Zeta Functions of Graphs: A Stroll through the Garden*. Cambridge Studies in Advanced Mathematics. Cambridge University Press, 2010.
- [71] W. Wallis, *A Beginner's Guide to Graph Theory*. Birkhäuser, 2010.
- [72] G. Viennot, *Heaps of pieces, I : Basic definitions and combinatorial lemmas*, vol. 1234 of *Lecture Notes in Mathematics*. Springer Berlin Heidelberg, 1986.
- [73] P. A. MacMahon, *Combinatory Analysis*. Cambridge [Eng.]: The University Press, 1915-16.
- [74] R. de Mello Koch and S. Ramgoolam, *A double coset ansatz for integrability in AdS/CFT*, *JHEP* **1206** (2012) 083, [[arXiv:1204.2153](#)].
- [75] F. Benini, F. Canoura, S. Cremonesi, C. Nunez, and A. V. Ramallo, *Unquenched flavors in the Klebanov-Witten model*, *JHEP* **0702** (2007) 090, [[hep-th/0612118](#)].
- [76] F. Bigazzi, A. L. Cotrone, and A. Paredes, *Klebanov-Witten theory with massive dynamical flavors*, *JHEP* **0809** (2008) 048, [[arXiv:0807.0298](#)].
- [77] S. Benvenuti, B. Feng, A. Hanany, and Y.-H. He, *Counting BPS Operators in Gauge Theories: Quivers, Syzygies and Plethystics*, *JHEP* **0711** (2007) 050, [[hep-th/0608050](#)].

-
- [78] J. Gray, A. Hanany, Y.-H. He, V. Jejjala, and N. Mekareeya, *SQCD: A Geometric Apercu*, *JHEP* **0805** (2008) 099, [[arXiv:0803.4257](#)].
- [79] S. Cremonesi, G. Ferlito, A. Hanany, and N. Mekareeya, *Coulomb Branch and The Moduli Space of Instantons*, [arXiv:1408.6835](#).
- [80] M. R. Douglas, B. R. Greene, and D. R. Morrison, *Orbifold resolution by D-branes*, *Nucl.Phys.* **B506** (1997) 84–106, [[hep-th/9704151](#)].
- [81] R. Bhattacharyya, R. de Mello Koch, and M. Stephanou, *Exact Multi-Restricted Schur Polynomial Correlators*, *JHEP* **0806** (2008) 101, [[arXiv:0805.3025](#)].
- [82] K. A. Intriligator and B. Wecht, *RG fixed points and flows in SQCD with adjoints*, *Nucl.Phys.* **B677** (2004) 223–272, [[hep-th/0309201](#)].
- [83] M. Hamermesh, *Group Theory and its Application to Physical Problems*. Dover Publications, 1989.
- [84] R. Goodman and N. Wallach, *Representations and Invariants of the Classical Groups*. Encyclopedia of Mathematics and its Applications. Cambridge University Press, 2000.
- [85] A. Ram, “Representation theory; dissertation, chapter 1.” <http://www.ms.unimelb.edu.au/~ram/Preprints/dissertationChapt1.pdf>, 1990. Accessed: 18 January 2016.
- [86] R. Bhattacharyya, R. de Mello Koch, and M. Stephanou, *Exact Multi-Restricted Schur Polynomial Correlators*, *JHEP* **06** (2008) 101, [[arXiv:0805.3025](#)].
- [87] F. Larsen and E. J. Martinec, *$U(1)$ charges and moduli in the $D1 - D5$ system*, *JHEP* **06** (1999) 019, [[hep-th/9905064](#)].
- [88] S. Danz, J. Ellers, and J. Murray, *The centralizer of a subgroup in a group algebra*, *Proceedings of the Edinburgh Mathematical Society (Series 2)* (2013) 49–56.
- [89] D. Vaman and H. L. Verlinde, *Bit strings from $N=4$ gauge theory*, *JHEP* **11** (2003) 041, [[hep-th/0209215](#)].
- [90] T. Brown, *Cut-and-join operators and $N=4$ super Yang-Mills*, *JHEP* **1005** (2010) 058, [[arXiv:1002.2099](#)].
- [91] J. Pasukonis and S. Ramgoolam, *From counting to construction of BPS states in $N=4$ SYM*, *JHEP* **1102** (2011) 078, [[arXiv:1010.1683](#)].
- [92] V. Balasubramanian, J. de Boer, V. Jejjala, and J. Simon, *The Library of Babel: On the origin of gravitational thermodynamics*, *JHEP* **12** (2005) 006, [[hep-th/0508023](#)].
- [93] V. Balasubramanian, B. Czech, K. Larjo, and J. Simon, *Integrability versus information loss: A Simple example*, *JHEP* **11** (2006) 001, [[hep-th/0602263](#)].

-
- [94] G. W. Moore and G. Segal, *D-branes and K-theory in 2D topological field theory*, [hep-th/0609042](#).
- [95] D. Berenstein and R. G. Leigh, *Resolution of stringy singularities by noncommutative algebras*, *JHEP* **06** (2001) 030, [[hep-th/0105229](#)].
- [96] Y. Kimura, *Noncommutative Frobenius algebras and open strings*, *Talk at Queen Mary University of London* (2014).
- [97] J. Ben Geloun and S. Ramgoolam, *Counting Tensor Model Observables and Branched Covers of the 2-Sphere*, [arXiv:1307.6490](#).
- [98] A. Mironov, A. Morozov, and S. Natanzon, *A Hurwitz theory avatar of open-closed strings*, *Eur. Phys. J.* **C73** (2013), no. 2 2324, [[arXiv:1208.5057](#)].
- [99] G. Viennot, *Cours Universidad de Talca: Heaps of pieces - with interactions in mathematics and physics*. 2013-2014. Accessed: 16 December 2014.
- [100] M. Kruczenski, D. Mateos, R. C. Myers, and D. J. Winters, *Meson spectroscopy in AdS / CFT with flavor*, *JHEP* **0307** (2003) 049, [[hep-th/0304032](#)].
- [101] F. Cachazo, M. R. Douglas, N. Seiberg, and E. Witten, *Chiral rings and anomalies in supersymmetric gauge theory*, *JHEP* **0212** (2002) 071, [[hep-th/0211170](#)].
- [102] M. A. Luty and W. Taylor, *Varieties of vacua in classical supersymmetric gauge theories*, *Phys.Rev.* **D53** (1996) 3399–3405, [[hep-th/9506098](#)].
- [103] J. Kinney, J. M. Maldacena, S. Minwalla, and S. Raju, *An Index for 4 dimensional super conformal theories*, *Commun.Math.Phys.* **275** (2007) 209–254, [[hep-th/0510251](#)].
- [104] Y. Nakayama, *Index for orbifold quiver gauge theories*, *Phys.Lett.* **B636** (2006) 132–136, [[hep-th/0512280](#)].
- [105] A. Gadde, E. Pomoni, L. Rastelli, and S. S. Razamat, *S-duality and 2d Topological QFT*, *JHEP* **1003** (2010) 032, [[arXiv:0910.2225](#)].
- [106] S. Kim, *The Complete superconformal index for N=6 Chern-Simons theory*, *Nucl.Phys.* **B821** (2009) 241–284, [[arXiv:0903.4172](#)].
- [107] Y. Kimura, *Quarter BPS classified by Brauer algebra*, *JHEP* **1005** (2010) 103, [[arXiv:1002.2424](#)].
- [108] A. Hanany, N. Mekareeya, and G. Torri, *The Hilbert Series of Adjoint SQCD*, *Nucl.Phys.* **B825** (2010) 52–97, [[arXiv:0812.2315](#)].
- [109] N. Jokela, M. Jarvinen, and E. Keski-Vakkuri, *New results for the SQCD Hilbert series*, *JHEP* **1203** (2012) 048, [[arXiv:1112.5454](#)].

- [110] T. Harmark and M. Orselli, *Spin Matrix Theory: A quantum mechanical model of the AdS/CFT correspondence*, [arXiv:1409.4417](#).
- [111] R. d. M. Koch and S. Ramgoolam, *From Matrix Models and Quantum Fields to Hurwitz Space and the absolute Galois Group*, [arXiv:1002.1634](#).
- [112] R. Gopakumar, *What is the Simplest Gauge-String Duality?*, [arXiv:1104.2386](#).
- [113] R. Gopakumar and R. Pius, *Correlators in the Simplest Gauge-String Duality*, *JHEP* **03** (2013) 175, [[arXiv:1212.1236](#)].
- [114] R. de Mello Koch and L. Nkumane, *Topological String Correlators from Matrix Models*, *JHEP* **03** (2015) 004, [[arXiv:1411.5226](#)].
- [115] L. Freidel, D. Garner, and S. Ramgoolam, *Permutation combinatorics of worldsheet moduli space*, *Phys. Rev.* **D91** (2015), no. 12 126001, [[arXiv:1412.3979](#)].
- [116] A. Gadde, E. Pomoni, and L. Rastelli, *The Veneziano Limit of $N = 2$ Superconformal QCD: Towards the String Dual of $N = 2$ $SU(N(c))$ SYM with $N(f) = 2 N(c)$* , [arXiv:0912.4918](#).
- [117] V. De Comarmond, R. de Mello Koch, and K. Jefferies, *Surprisingly Simple Spectra*, *JHEP* **02** (2011) 006, [[arXiv:1012.3884](#)].
- [118] I. MacDonald, *The Theory of Groups*. Clarendon Press, 1968.