

Title of paper:

Many Valued Generalised Quantifiers for Natural Language in the DisCoCat Model

Author:

Matej Dostal and Mehrnoosh Sadrzadeh

EECSRR-16-04

November 2016

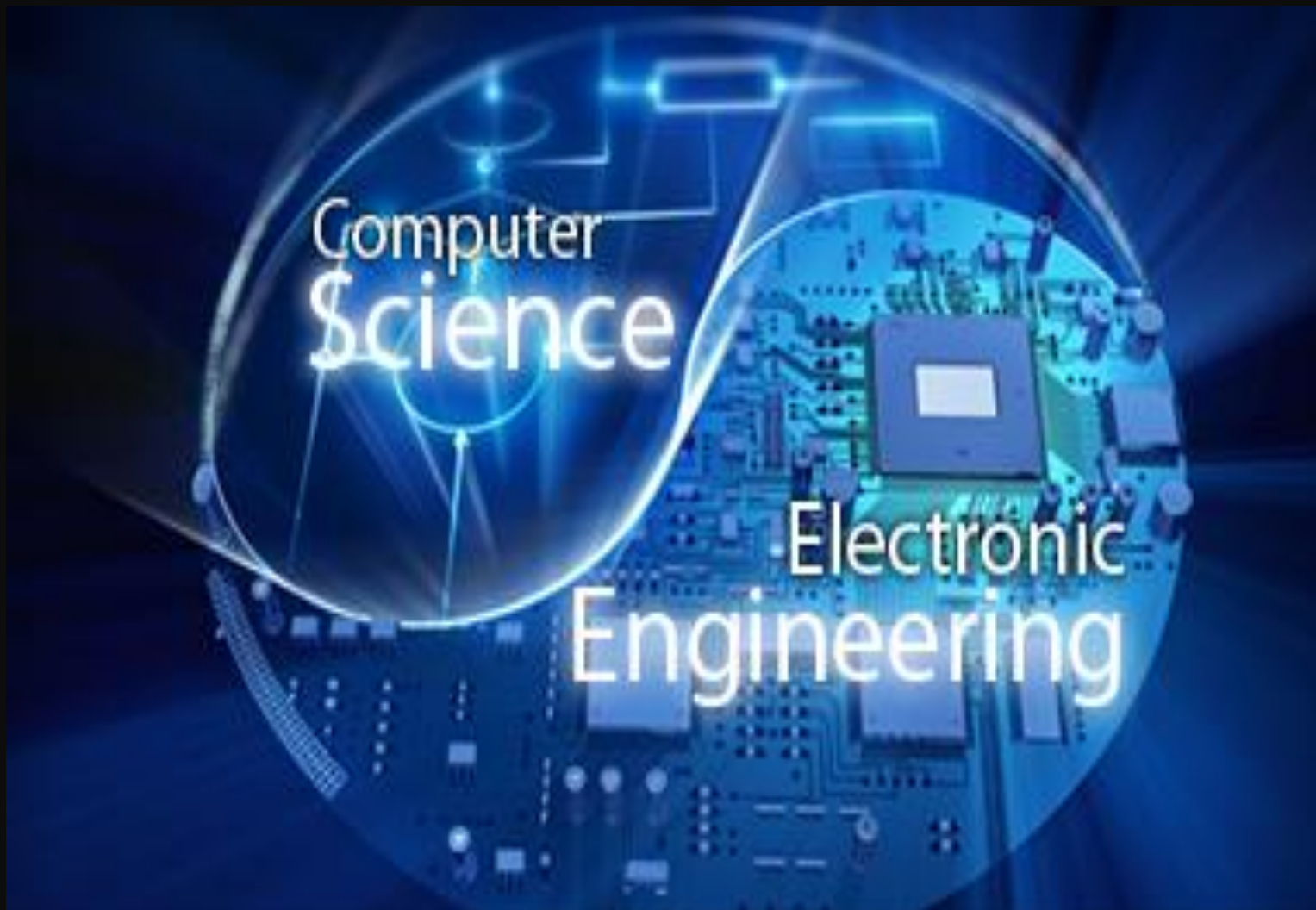

Many Valued Generalised Quantifiers for Natural Language in the DisCoCat Model

Matej Dostal and Mehrnoosh Sadrzadeh

Faculty of Electronics, Czech Technical University, Prague,
School of Electronic Engineering and Computer Science, Queen Mary University of London
dostamat@fel.cvut.cz, mehrnoosh.sadrzadeh@qmul.ac.uk

Abstract. DisCoCat refers to the Categorical compositional distributional model of natural language, which combines the statistical vector space models of words with the compositional logic-based models of grammar. It is fair to say that despite existing work on incorporating notions of entailment, quantification, and coordination in this setting, a uniform modelling of logical operations is still an open problem. In this report, we take a step towards an answer. We show how one can generalise our previous DisCoCat model of generalised quantifiers from category of sets and relations to category of sets and many valued relations. As a result, we get a fuzzy version of these quantifiers. Our aim is to extend this model to all other logical connectives and develop a fuzzy logic for DisCoCat. The main contributions are showing that category of many valued relations is compact closed, defining appropriate bialgebra structures over it, and demonstrating how one can compute within this setting many valued meanings for quantified sentences.

1 Introduction

DisCoCat stands for **D**istributional **C**ompositional **C**ategorical. It is a short name for a model of natural language that combines the statistical vector space models of word meanings with the compositional models of phrase and sentence grammar, using the theory of categories and in particular compact closed categories [11]. The main references for the underlying theory of this model are [19, 3, 15, 4]. The theoretical predictions of this model have been validated on real large scale data, for example see the work done in [6–8, 10, 14]. The original DisCoCat model covers a preliminary fragment of natural language and does not include logical words such as relative pronouns, quantifiers and coordination words such as conjunction and disjunction. In [20, 17, 18], we modelled relative pronouns using Frobenius algebras over compact closed categories. In [9, 16] we showed how one can use bialgebras to model generalised quantifiers. The line of work pursued in this report aims to provide a step towards modelling conjunction and disjunction, and developing a uniform logic for the setting.

In order to model the quantities encoded by the vector models of natural language, we have so far worked with the vector space instantiation of DisCoCat. Here, we are of course referring to the category of finite dimensional vector spaces and linear maps, which is compact closed and also has Frobenius and bialgebras over it. The concrete setting of vector spaces does not admit a natural form of logic in the following sense: it is not clear what is the conjunction or disjunction of vector spaces or the vectors therein. On the contrary, category of sets and relations is also compact closed and has Frobenius and bialgebras over it and allows for a boolean logic, via the set theoretic operations thereof, however, it does not have any quantities in it. Our current work is about a middle way out to solve the problem: we suggest to work in the category of sets and many valued relations. This category does have a natural notion of logic in it and does model quantities as well it provides a categorical model for fuzzy logic via the structure of MV -algebras.

In what follows, we show that the category of sets and many valued relations is compact closed and that it has bialgebras over it. We develop a many valued instantiation of the abstract compact closed

categorical semantics of [9] in this category. We subsequently develop a many valued version of some of the natural language generalised quantifiers and show how, via these definitions and the morphisms provided by the category, one can compute many valued meanings for the quantified sentences of natural language.

Our work in progress constitutes of linking the model of this work to vectors in a formal way and then applying the result to reason about real natural language data in tasks such as entailment.

2 Generalised Quantifiers in Natural Language

We briefly review the theory of generalised quantifiers in natural language as presented in [1]. Consider the fragment of English generated by the following context free grammar:

S → NP VP	NP → John, Mary, something, ...
VP → V NP	N → cat, dog, man, ...
NP → Det N	VP → sneeze, sleep, ...
	V → love, kiss, ...
	Det → a, the, some, every, each, all, no, most, few, one, two, ...

A model for the language generated by this grammar is a pair $(U, \llbracket \cdot \rrbracket)$, where U is a universal reference set and $\llbracket \cdot \rrbracket$ is an interpretation function defined by induction as follows.

– On terminals.

- The interpretation of a determiner d generated by ‘Det → d ’ is a map with the following type:

$$\llbracket d \rrbracket: \mathcal{P}(U) \rightarrow \mathcal{P}\mathcal{P}(U)$$

It assigns to each $A \subseteq U$, a family of subsets of U . The images of these interpretations are referred to as *generalised quantifiers*. For logical quantifiers, they are defined as follows:

$$\begin{aligned} \llbracket \text{some} \rrbracket(A) &= \{X \subseteq U \mid X \cap A \neq \emptyset\} \\ \llbracket \text{every} \rrbracket(A) &= \{X \subseteq U \mid A \subseteq X\} \\ \llbracket \text{no} \rrbracket(A) &= \{X \subseteq U \mid A \cap X = \emptyset\} \\ \llbracket n \rrbracket(A) &= \{X \subseteq U \mid |X \cap A| = n\} \end{aligned}$$

A similar method is used to define non-logical quantifiers, for example “most A ” is defined to be the set of subsets of U that has ‘most’ elements of A , “few A ” is the set of subsets of U that contain ‘few’ elements of A , and similarly for ‘several’ and ‘many’.

- The interpretation of a terminal $y \in \{np, n, vp\}$ generated by either of the rules ‘NP → np, N → n, VP → vp’ is $\llbracket y \rrbracket \subseteq U$. That is, noun phrases, nouns and verb phrases are interpreted as subsets of the reference set.
 - The interpretation of a terminal y generated by the rule V → y is $\llbracket y \rrbracket \subseteq U \times U$. That is, verbs are interpreted as binary relations over the reference set.
- On non-terminals.
- The interpretation of expressions generated by the rule ‘NP → Det N’ is as follows:

$$\begin{aligned} \llbracket \text{Det N} \rrbracket &= \llbracket d \rrbracket(\llbracket n \rrbracket) \quad \text{where} \quad X \in \llbracket d \rrbracket(\llbracket n \rrbracket) \text{ iff } X \cap \llbracket n \rrbracket \in \llbracket d \rrbracket(\llbracket n \rrbracket) \\ &\quad \text{for} \quad \text{Det} \rightarrow d \text{ and } N \rightarrow n \end{aligned}$$

- The interpretations of expressions generated by other rules are as usual, that is

$$\llbracket V NP \rrbracket = \llbracket v \rrbracket(\llbracket np \rrbracket) \quad \llbracket NP VP \rrbracket = \llbracket vp \rrbracket(\llbracket np \rrbracket)$$

Here, for $R \subseteq U \times U$ and $A \subseteq U$, by $R(A)$ we mean the forward image of R on A , that is $R(A) = \{y \mid (x, y) \in R, \text{ for } x \in A\}$. To keep the notation unified, for R a unary relation $R \subseteq U$, we use the same notation and define $R(A) = \{y \mid y \in R, \text{ for } x \in A\}$, i.e. $R \cap A$.

The expressions generated by the rule ‘NP \rightarrow Det N’ satisfy a property referred to by *living on or conservativity*, defined below.

Definition 1. For a terminal d generated by the rule ‘Det $\rightarrow d$ ’, we say that $\llbracket d \rrbracket(A)$ lives on A whenever $X \in \llbracket d \rrbracket(A)$ iff $X \cap A \in \llbracket d \rrbracket(A)$, for $A, X \subseteq U$.

The ‘meaning’ of a sentence is its truth value, defined as follows:

Definition 2. The meaning of a sentence in generalised quantifier theory is true iff $\llbracket NP VP \rrbracket \neq \emptyset$.

As an example, meaning of a sentence with a quantified phrase at its subject position becomes as follows:

$$\llbracket \text{Det N VP} \rrbracket = \begin{cases} \text{true} & \text{if } \llbracket vp \rrbracket \cap \llbracket n \rrbracket \in \llbracket \text{Det N} \rrbracket \\ \text{false} & \text{otherwise} \end{cases}$$

For instance, meaning of ‘some men sneeze’, which is of this form, is true iff $\llbracket \text{sneeze} \rrbracket \cap \llbracket \text{men} \rrbracket \in \llbracket \text{some men} \rrbracket$, that is, whenever the set of things that sneeze and are men is a non-empty set. As another example, consider the meaning of a sentence with a quantified phrase at its object position, whose meaning is as follows:

$$\llbracket NP V \text{Det N} \rrbracket = \begin{cases} \text{true} & \text{if } \llbracket np \rrbracket \cap \llbracket v \rrbracket(\llbracket np \rrbracket) \in \llbracket \text{Det N} \rrbracket \\ \text{false} & \text{otherwise} \end{cases}$$

An example of this case is the meaning of ‘John liked some trees’, which is true iff $\llbracket \text{trees} \rrbracket \cap \llbracket \text{like} \rrbracket(\llbracket \text{John} \rrbracket) \in \llbracket \text{some trees} \rrbracket$, that is, whenever, the set of things that are liked by John and are trees is a non-empty set. Similarly, the sentence ‘John liked five trees’ is true iff the set of things that are liked by John and are trees has five elements in it.

3 Category Theoretic and Diagrammatic Definitions

This subsection briefly reviews compact closed categories and bialgebras. For a formal presentation, see [11–13]. A compact closed category, \mathcal{C} , has objects A, B ; morphisms $f: A \rightarrow B$; and a monoidal tensor $A \otimes B$ that has a unit I , that is we have $A \otimes I \cong I \otimes A \cong A$. Furthermore, for each object A there are two objects A^r and A^l and the following morphisms:

$$A \otimes A^r \xrightarrow{\epsilon_A^r} I \xrightarrow{\eta_A^r} A^r \otimes A \quad A^l \otimes A \xrightarrow{\epsilon_A^l} I \xrightarrow{\eta_A^l} A \otimes A^l$$

These morphisms satisfy the following equalities, where 1_A is the identity morphism on object A :

$$\begin{aligned} (1_A \otimes \epsilon_A^l) \circ (\eta_A^l \otimes 1_A) &= 1_A & (\epsilon_A^r \otimes 1_A) \circ (1_A \otimes \eta_A^r) &= 1_A \\ (\epsilon_A^l \otimes 1_A) \circ (1_{A^l} \otimes \eta_A^l) &= 1_{A^l} & (1_{A^r} \otimes \epsilon_A^r) \circ (\eta_A^r \otimes 1_{A^r}) &= 1_{A^r} \end{aligned}$$

These express the fact the A^l and A^r are the left and right adjoints, respectively, of A in the 1-object bicategory whose 1-cells are objects of \mathcal{C} . A self adjoint compact closed category is one in which for every object A we have $A^l \cong A^r \cong A$.

Given two compact closed categories \mathcal{C} and \mathcal{D} a strongly monoidal functor $F: \mathcal{C} \rightarrow \mathcal{D}$ is defined as follows:

$$F(A \otimes B) = F(A) \otimes F(B) \quad F(I) = I$$

One can show that this functor preserves the compact closed structure, that is we have:

$$F(A^l) = F(A)^l \quad F(A^r) = F(A)^r$$

A bialgebra in a symmetric monoidal category $(\mathcal{C}, \otimes, I, \sigma)$ is a tuple $(X, \delta, \iota, \mu, \zeta)$ where, for X an object of \mathcal{C} , the triple (X, δ, ι) is an internal comonoid; i.e. the following are coassociative and counital morphisms of \mathcal{C} :

$$\delta: X \rightarrow X \otimes X \qquad \qquad \qquad \iota: X \rightarrow I$$

Moreover (X, μ, ζ) is an internal monoid; i.e. the following are associative and unital morphisms:

$$\mu: X \otimes X \rightarrow X \qquad \qquad \qquad \zeta: I \rightarrow X$$

And finally δ and μ satisfy the four equations [13]

$$\iota \circ \mu = \iota \otimes \iota \qquad \qquad \qquad \text{(Q1)}$$

$$\delta \circ \zeta = \zeta \otimes \zeta \qquad \qquad \qquad \text{(Q2)}$$

$$\delta \circ \mu = (\mu \otimes \mu) \circ (\text{id}_X \otimes \sigma_{X,X} \otimes \text{id}_X) \circ (\delta \otimes \delta) \qquad \text{(Q3)}$$

$$\iota \circ \zeta = \text{id}_I \qquad \qquad \qquad \text{(Q4)}$$

Informally, the comultiplication δ dispatches to copies the information contained in one object into two objects, and the multiplication μ unifies or merges the information of two objects into one. In what follows, we present three examples of compact closed categories, two of which with bialgebras.

Example. Sets and Relations. An example of a compact closed category is Rel , the category of sets and relations. Here, \otimes is cartesian product with the singleton set as its unit $I = \{\star\}$, and $*$ is identity on objects. Hence Rel is also self adjoint. Closure reduces to the fact that a relation between sets $A \times B$ and C is equivalently a relation between A and $B \times C$. Given a set S with elements $s_i, s_j \in S$, the epsilon and eta maps are given as follows:

$$\begin{aligned} \epsilon^l = \epsilon^r : S \times S \rightarrow \{\star\} & \text{ given by } (s_i, s_j)\epsilon\star \iff s_i = s_j \\ \eta^l = \eta^r : \{\star\} \rightarrow S \times S & \text{ given by } \star\eta(s_i, s_j) \iff s_i = s_j \end{aligned}$$

For an object in Rel of the form $W = \mathcal{P}(U)$, we give W a bialgebra structure by taking

$$\begin{aligned} \delta: S \rightarrow S \times S & \text{ given by } A\delta(B, C) \iff A = B = C \\ \iota: S \rightarrow \{\star\} & \text{ given by } A\iota\star \iff \text{(always true)} \\ \mu: S \times S \rightarrow S & \text{ given by } (A, B)\mu C \iff A \cap B = C \\ \zeta: \{\star\} \rightarrow S & \text{ given by } \star\zeta A \iff A = U \end{aligned}$$

The axioms (Q1) – (Q4) can be easily verified by the reader.

It should be noted that since both FdVect and Rel are \dagger -categories, these constructions dualize to give two bialgebras. However these bialgebras are not interacting in the sense of [2], and the Frobenius axiom does not hold for either. Because these bialgebras are not Frobenius we do not get a spider theorem, in the sense of [5].

In the next section we show how category of Sets and Many Valued Relations is also an example of a self adjoint compact closed category with bialgebras over it.

3.1 String Diagrams

The framework of compact closed categories and bialgebras comes with a diagrammatic calculus that visualises derivations, and which also simplifies the categorical and vector space computations. Morphisms are depicted by boxes and objects by lines, representing their identity morphisms. For instance a morphism $f: A \rightarrow B$, and an object A with the identity arrow $1_A: A \rightarrow A$, are depicted as follows:

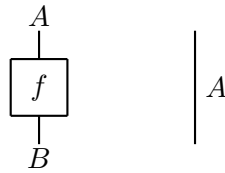

Morphisms from I to objects are depicted by triangles with strings emanating from them. In concrete categories, these morphisms represent elements within the objects. For instance, an element a in A is represented by the morphism $a: I \rightarrow A$ and depicted by a triangle with one string emanating from it. The number of strings of such triangles depict the tensor rank of the element; for instance, the diagrams for $a \in A$, $a' \in A \otimes B$, and $a'' \in A \otimes B \otimes C$ are as follows:

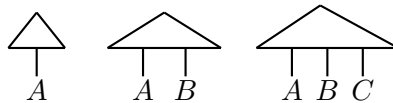

The tensor products of the objects and morphisms are depicted by juxtaposing their diagrams side by side, whereas compositions of morphisms are depicted by putting one on top of the other; for instance the object $A \otimes B$, and the morphisms $f \otimes g$ and $h \circ f$, for $f: A \rightarrow B$, $g: C \rightarrow D$, and $h: B \rightarrow C$, are depicted as follows:

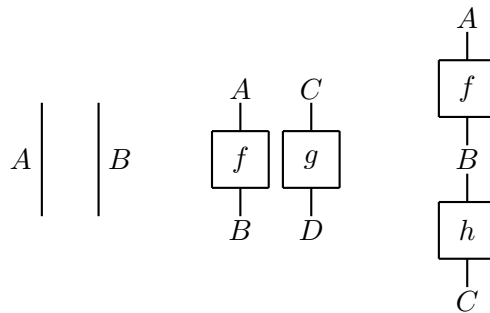

The ϵ maps are depicted by cups, η maps by caps, and yanking by their composition and straightening of the strings. For instance, the diagrams for $\epsilon^l: A^l \otimes A \rightarrow I$, $\eta: I \rightarrow A \otimes A^l$ and $(\epsilon^l \otimes 1_A) \circ (1_A \otimes \eta^l) = 1_A$ are as follows:

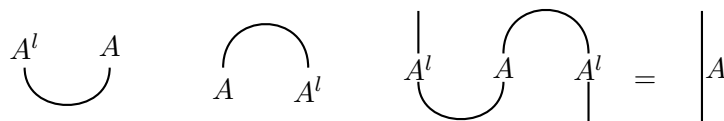

As for the bialgebra, the diagrams for the monoid and comonoid morphisms and their interaction (the bialgebra law Q3) are as follows:

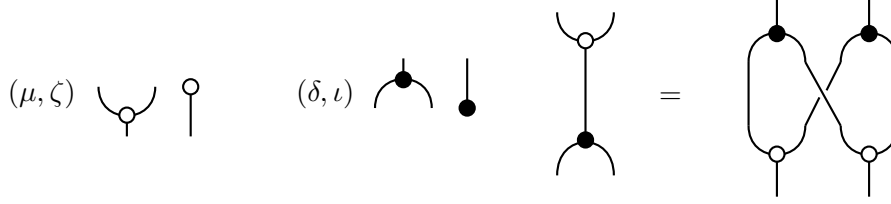

4 Category of Sets and Many Valued Relations

Definition 3 (Commutative quantale). A commutative quantale \mathcal{V} is a complete lattice (V, \wedge, \vee) with the structure of a commutative monoid (V, \bullet, e) such that the tensor is monotone and distributes over arbitrary joins.

More in detail, \mathcal{V} being a complete lattice means that V is partially ordered by \leq and every subset $V' \subseteq V$ has an infimum (or meet) and a supremum (or join), denoted by $\bigwedge V'$ and $\bigvee V'$ respectively. From this it follows that V contains the greatest element \top and the lowest element \perp . The fact that (V, \bullet, e) is a commutative monoid means that \bullet is commutative, associative, and e is the identity element:

$$v \bullet e = v = e \bullet v.$$

The monotonicity of the tensor requires that

$$v \bullet w \leq v' \bullet w$$

holds for $v \leq v'$, and distributivity of tensor over arbitrary joins means that the following equality

$$\left(\bigvee_i x_i \right) \bullet y = \bigvee_i (x_i \bullet y)$$

is satisfied.

Definition 4 (Complete Heyting algebra). A complete Heyting algebra \mathcal{V} is a commutative quantale where $\bullet = \wedge$ and $e = \top$. In other words, it is a complete lattice (V, \wedge, \vee) where the meet operation distributes over arbitrary joins:

$$\left(\bigvee_i x_i \right) \wedge y = \bigvee_i (x_i \wedge y).$$

Definition 5 (Gödel chain). We say that a complete Heyting algebra \mathcal{V} is a Gödel chain if the ordering relation \leq of the underlying lattice of \mathcal{V} is a linear order, that is, for two elements $v \neq v'$ it either holds that $v \leq v'$ or $v' \leq v$.

Example 1. Instances of commutative quantales:

1. The real interval $[0, 1]$ with the usual lattice structure (given by computing suprema and infima), the tensor being the meet and the unit being 1, is a complete Heyting algebra, moreover a Gödel chain.
2. The real interval $[0, 1]$ with the usual structure, the unit 1 and the tensor being defined as

$$a \bullet b = \max(0, a + b - 1)$$

is a commutative quantale.

3. The real interval $[0, 1]$ with the usual structure, the unit 1 and the tensor being defined as

$$a \bullet b = a \cdot b$$

(multiplication) is a commutative quantale.

4. As a very special case, the 2-element Boolean algebra is a commutative quantale.

Definition 6 (Many-valued relation). For a given quantale \mathcal{V} , a many-valued relation $R : A \dashv\rightarrow B$ is a function $R : A \times B \rightarrow \mathcal{V}$. We view this function as a \mathcal{V} -valued matrix.

We compose two relations $R : A \dashv\rightarrow B$ and $S : B \dashv\rightarrow C$ to get a relation $S \circ R : A \dashv\rightarrow C$ such that

$$(S \circ R)(a, c) = \bigvee_{b \in B} (R(a, b) \bullet S(b, c))$$

holds in \mathcal{V} .

Definition 7 (The category of \mathcal{V} -relations). The collection of all sets and of \mathcal{V} -relations between sets is a category. There is an identity \mathcal{V} -relation id_A for every set A :

$$id_A(a, a') = \begin{cases} e & \text{if } a = a' \\ \perp & \text{otherwise.} \end{cases}$$

An easy computation yields that \mathcal{V} -relation composition is associative. We denote the category of all sets and \mathcal{V} -relations as $\mathcal{V}\text{-Rel}$.

Remark 1. The associativity of \mathcal{V} -relation composition follows from complete distributivity of \mathcal{V} . For \mathcal{V} -relations over finite sets, only finite distributivity of tensor over joins would be needed.

Example 2. Some examples of $\mathcal{V}\text{-Rel}$ for various choices of \mathcal{V} :

1. When \mathcal{V} is the 2-element Boolean algebra, $\mathcal{V}\text{-Rel}$ is the category Rel of sets and (ordinary) relations.
2. When \mathcal{V} is the real interval $[0, 1]$ with Gödel operations \min and \max , the category $\mathcal{V}\text{-Rel}$ has sets as objects, and the composition of morphisms (\mathcal{V} -relations) acts as follows. Given two \mathcal{V} -relations $R : A \dashv\rightarrow B$ and $S : B \dashv\rightarrow C$ (so two functions $R : A \times B \rightarrow [0, 1]$ and $S : B \times C \rightarrow [0, 1]$), the composite $S \circ R : A \dashv\rightarrow C$ is given by

$$(S \circ R)(a, c) = \max_{b \in B} \min(R(a, b), S(b, c)).$$

Given yet another \mathcal{V} -relation $T : C \dashv\rightarrow D$, the composite $T \circ S \circ R$ is then computed as follows:

$$(T \circ S \circ R)(a, d) = \max_{b \in B, c \in C} \min(R(a, b), S(b, c), T(c, d)).$$

Remark 2. Observe that there is an inclusion functor

$$\widetilde{(-)} : \text{Rel} \rightarrow \mathcal{V}\text{-Rel}$$

for any \mathcal{V} with more than one element. Indeed, let the functor act as an identity on objects, and assign to a relation $R : A \dashv\rightarrow B$ the \mathcal{V} -valued relation $\widetilde{R} : A \dashv\rightarrow B$ defined as follows:

$$\widetilde{R}(a, b) = \begin{cases} e & \text{if } R(a, b) \text{ holds,} \\ \perp & \text{otherwise.} \end{cases}$$

An easy computation yields that $\widetilde{id_A} = id_A$ and that $\widetilde{S \circ R} = \widetilde{S} \circ \widetilde{R}$.

Lemma 1. *The category $\mathcal{V}\text{-Rel}$ is a self adjoint compact closed category with the cartesian product being the tensor \otimes and the unit I being the singleton set $\{\star\}$.*

Proof. Let us define the epsilon maps $\epsilon_S : S \times S \rightarrow I$ for each S as follows

$$\epsilon_S((a, b), \star) = \begin{cases} e & \text{if } a = b \\ \perp & \text{otherwise} \end{cases}$$

and define the eta maps $\eta_S : I \rightarrow S \times S$ similarly:

$$\eta_S(\star, (a, b)) = \begin{cases} e & \text{if } a = b \\ \perp & \text{otherwise} \end{cases}$$

Since with these definitions the epsilon and eta maps are the images of the epsilon and eta maps from Rel under the inclusion functor $\widehat{(-)} : \text{Rel} \rightarrow \mathcal{V}\text{-Rel}$, the axioms of a compact closed category hold in $\mathcal{V}\text{-Rel}$. It remains to show that ϵ and η are natural; but this is straightforward.

Remark 3. Let us fix a set U . Very similarly to the case of Rel , we can define a bialgebra over the set $S = P(U)$ in $\mathcal{V}\text{-Rel}$ by the following data. The relation $\delta : S \rightarrow S \times S$ is defined as

$$\delta(A, (B, C)) = \begin{cases} e & \text{if } A = B = C \\ \perp & \text{otherwise.} \end{cases}$$

The relation $\mu : S \times S \rightarrow S$ is defined as

$$\mu((A, B), C) = \begin{cases} e & \text{if } A \cap B = C \\ \perp & \text{otherwise.} \end{cases}$$

The relation $\iota : S \rightarrow I$ is defined as

$$\iota(A, \star) = e \text{ for every } A.$$

The relation $\zeta : I \rightarrow S$ is defined as

$$\zeta(\star, A) = \begin{cases} e & \text{if } A = U \\ \perp & \text{otherwise.} \end{cases}$$

In fact, we obtain the structure of a bialgebra over $P(U)$ in $\mathcal{V}\text{-Rel}$ by taking the bialgebra structure over $P(U)$ in Rel and applying the inclusion functor $\widehat{(-)}$.

5 Interpretation of sentence meaning in $\mathcal{V}\text{-Rel}$

Remark 4. We are given a model $(U, \llbracket \cdot \rrbracket)$, i.e., a set (universe) U and an interpretation function $\llbracket \cdot \rrbracket$ which for a terminal $y \in \{np, n, vp\}$ is $\llbracket y \rrbracket : U \rightarrow \mathcal{V}$ (a \mathcal{V} -fuzzy subset of U). The interpretation of a verb $V \rightarrow y$ is a \mathcal{V} -relation $\llbracket y \rrbracket : U \rightarrow U$.

The interpretation of a determiner d is a \mathcal{V} -relation $P(U) \rightarrow P(U)$. We shall inspect some possible definitions of generalised fuzzy quantifiers below.

Remark 5. Some examples of possible definitions of generalised fuzzy quantifiers for $\mathcal{V} = [0, 1]$:

1. The quantifier “every” can still be thought as crisp (non-fuzzy): $\overline{\llbracket \text{every} \rrbracket} : P(U) \rightarrow P(U)$ can be defined as follows.

$$\overline{\llbracket \text{every} \rrbracket}(A, B) = \begin{cases} e & \text{if } A \subseteq B, \\ \perp & \text{otherwise.} \end{cases}$$

2. The quantifier “almost all” admits numerous possible definitions. One such possibility is to consider it false if less than 90 % cases hold, and decrease its truth value linearly from the 100 % case. This can be achieved by defining $\overline{\llbracket \text{almost all} \rrbracket} : P(U) \rightarrow P(U)$ as

$$\overline{\llbracket \text{almost all} \rrbracket}(A, B) = \begin{cases} \frac{|A \cap B|}{|A|} & \text{if } \frac{|A \cap B|}{|A|} > 0.1 \\ \perp & \text{otherwise.} \end{cases}$$

3. For the “some” quantifier we may again use the crisp semantics, as they model the usage in natural language satisfactorily:

$$\overline{\llbracket \text{some} \rrbracket}(A, B) = \begin{cases} e & \text{if } A \cap B \neq \emptyset, \\ \perp & \text{otherwise.} \end{cases}$$

4. The semantics for the counting quantifiers like “five” or “six” may be thought as crisp as well; their fuzzy counterparts being “around five” or “around six”; possible semantics:

$$\overline{\llbracket \text{around five} \rrbracket}(A, B) = \begin{cases} e & \text{if } |A \cap B| = 5 \\ 0.5 & \text{if } |A \cap B| = 4 \text{ or } |A \cap B| = 6 \\ \perp & \text{otherwise.} \end{cases}$$

Remark 6. Given a model $(U, \llbracket \cdot \rrbracket)$, there are at least two possible ways to instantiate the abstract semantics to a tuple $(\mathcal{V}\text{-Rel}, P(U), I, \llbracket \cdot \rrbracket)$. Firstly, they differ in the way of defining the interpretation of terminals. Let x be one of the terminals N, NP, or VP.

1. Denote by A_x^s the set $\{u \in U \mid \llbracket x \rrbracket(u) = s\}$. Then

$$\star \overline{\llbracket x \rrbracket} A = \begin{cases} s & \text{if } A = A_x^s \text{ for some } s \\ \perp & \text{otherwise.} \end{cases}$$

2. Denote by $A_x^{\geq s}$ the set $\{u \in U \mid \llbracket x \rrbracket(u) \geq s\}$. Then

$$\star \overline{\llbracket x \rrbracket} A = \begin{cases} s & \text{if } A = A_x^{\geq s} \text{ for some } s \\ \perp & \text{otherwise.} \end{cases}$$

Secondly, we may interpret transitive verbs v similarly in two different ways (recall that $\llbracket v \rrbracket$ is a relation $U \rightarrow U$):

1. Denote by A^s the set $\{u \in U \mid \exists a \in A : \llbracket v \rrbracket(a, u) = s\}$. Then

$$\star \overline{\llbracket v \rrbracket}(A, \star, B) = \begin{cases} s & \text{if } B = A^s \text{ for some } s \\ \perp & \text{otherwise.} \end{cases}$$

2. Denote by $A^{\geq s}$ the set $\{u \in U \mid \exists a \in A : \llbracket v \rrbracket(a, u) \geq s\}$. Then

$$\star \overline{\llbracket v \rrbracket}(A, \star, B) = \begin{cases} s & \text{if } B = A^{\geq s} \text{ for some } s \\ \perp & \text{otherwise.} \end{cases}$$

These definitions are all we need to compute many-valued semantics of sentences. For these, we observe the following.

Remark 7. The many valued semantics of a sentence with a quantified subject “ $d np vp$ ” is

$$\min \left(\star \overline{[np]} A, \star \overline{[vp]} B, F \overline{[d]} A \cap B \right)$$

for $A \subseteq \overline{[np]}$, $B \subseteq \overline{[vp]}$, and $F \subseteq \overline{[d]}(A)$.

To see this, recall that the abstract compact closed meaning of this sentence is

$$\epsilon \circ (\overline{[d]} \otimes \mu) \circ (\delta \otimes id) \circ (\overline{[np]} \otimes \overline{[vp]})$$

We compute this in four steps. In the first step, we compute the following map

$$\overline{[np]} \otimes \overline{[vp]}: \{\star\} \otimes \{\star\} \rightarrow \mathcal{P}(U) \otimes \mathcal{P}(U)$$

For $A, B \subseteq U$, the value returned by this map is as follows

$$(\star, \star)(\overline{[np]} \otimes \overline{[vp]})(A, B) = \min \left(\star \overline{[np]} A, \star \overline{[vp]} B \right)$$

In the second step, we compute the following map

$$(\delta \otimes id) \circ (\overline{[np]} \otimes \overline{[vp]}): \{\star\} \otimes \{\star\} \rightarrow \mathcal{P}(U) \otimes \mathcal{P}(U) \otimes \mathcal{P}(U)$$

For $C, D, E \subseteq U$, this maps returns the following value

$$(\star, \star)(\delta \otimes id) \circ (\overline{[np]} \otimes \overline{[vp]})((C, D), E)$$

equal to

$$\max_{(A,B)} \min \left((\star, \star)(\overline{[np]} \otimes \overline{[vp]})(A, B), (A, B)(\delta \otimes id)((C, D), E) \right)$$

The maximum value of the above is realised for (A, B) 's for which we have

$$A = C = D, \quad \text{and} \quad B = E$$

in which case this value is equal to the following

$$\min \left(\star \overline{[np]} A, \star \overline{[vp]} B \right)$$

as the δ and id maps return e in their best case and e is the unit of the min operation.

In the third step, we compute the following step:

$$(\overline{[d]} \otimes \mu) \circ (\delta \otimes id) \circ (\overline{[np]} \otimes \overline{[vp]}): \{\star\} \otimes \{\star\} \rightarrow \mathcal{P}(U) \otimes \mathcal{P}(U)$$

The value generated by this map is

$$(\star, \star)(\overline{[d]} \otimes \mu) \circ (\delta \otimes id) \circ (\overline{[np]} \otimes \overline{[vp]})(F, G)$$

equal to

$$\max_{(C,D),E)} \min \left((\star, \star)(\delta \otimes id) \circ (\overline{[np]} \otimes \overline{[vp]})((C, D), E), (C, (D, E))(\overline{[d]} \otimes \mu)(F, G) \right)$$

The maximum is realised for the largest F that makes the following true:

$$G = D \cap E, \quad \text{and} \quad \frac{|C \cap F|}{|C|} > 0.1$$

in which case this value is equal to

$$\min \left(\star \overline{[np]} A, \star \overline{[vp]} B, \frac{|C \cap F|}{|C|} \right) = \left(\star \overline{[np]} A, \star \overline{[vp]} B, \frac{|A \cap F|}{|A|} \right)$$

In the fourth step we compute the full map

$$\epsilon \circ (\overline{[d]} \otimes \mu) \circ (\delta \otimes id) \circ (\overline{[np]} \otimes \overline{[vp]}): \{\star\} \otimes \{\star\} \rightarrow \{\star\}$$

The value generated by the above is

$$(\star, \star) \epsilon \circ (\overline{[d]} \otimes \mu) \circ (\delta \otimes id) \circ (\overline{[np]} \otimes \overline{[vp]}) \star$$

equal to

$$\max_{(F,G)} \min \left((\star, \star) (\overline{[d]} \otimes \mu) \circ (\delta \otimes id) \circ (\overline{[np]} \otimes \overline{[vp]}) (F, G), (F, G) \epsilon \star \right)$$

The maximum here is realised when we have $F = G$, in which case it is equal to

$$\min \left(\star \overline{[np]} A, \star \overline{[vp]} B, \frac{|A \cap F|}{|A|} \right)$$

Remark 8. The many valued semantics of a sentence with quantified object “ $np \vee d \ np'$ ” is computed in the same lines as the previous case and has the following value

$$\min \left(\star \overline{[np]} A, \star \overline{[v]} (A, C), \star \overline{[np']} D, F \overline{[d]} C \cap D \right)$$

for $A \subseteq \overline{[np]}$, $D \subseteq \overline{[np']}$, and $(A, C) \subseteq \overline{[v]}$, and $F \subseteq \overline{[d]}(D)$.

Remark 9. The many valued semantics of a sentence with a quantified subject and a quantified object “ $d \ np \vee d' \ np'$ ” is

$$\min \left(\star \overline{[np]} A, F \overline{[d]} A \cap B, \star \overline{[v]} (B, C), \star \overline{[np']} D, F' \overline{[d']} C \cap D \right)$$

for $A \subseteq \overline{[np]}$, $D \subseteq \overline{[np']}$, $(B, C) \subseteq \overline{[v]}$, and $F \subseteq \overline{[d]}(A)$, $F' \subseteq \overline{[d']}(D)$.

Example 3. We give an example of a model and of the semantics of two sentences: an intransitive one with a quantified subject, a transitive one with a quantified object, and a transitive one with both a quantified subject and object. Suppose we have 10 cats and 10 mice, 9 of the cats sleep, and 8 of them chase all of the mice. Let's denote the sets of cats, mice, sleep, and chase as follows:

$$\begin{aligned} \overline{[\text{cats}]} &= \{c_1, c_2, \dots, c_{10}\}, & \overline{[\text{sleep}]} &= \{c_1, c_2, \dots, c_9\} \\ \overline{[\text{mice}]} &= \{m_1, m_2, \dots, m_{10}\}, & \overline{[\text{chase}]} &= \{(c_i, m_j) \mid 1 \leq i \leq 8, 1 \leq j \leq 10\} \end{aligned}$$

Suppose all cats fully sleep and all of them fully chase the mice, so the many valued relations are

$$\begin{aligned} \forall A \subseteq \overline{[\text{cats}]}, \forall B \subseteq \overline{[\text{sleep}]}, & \quad \star \overline{[\text{cats}]} A = 1, \star \overline{[\text{sleep}]} B = 1 \\ \forall A \subseteq \overline{[\text{cats}]}, \forall D \subseteq \overline{[\text{mice}]}, \forall (B, C) \subseteq \overline{[\text{chase}]}, & \quad \star \overline{[\text{cats}]} A = e, \star \overline{[\text{mice}]} D = e, \star \overline{[\text{chase}]} (B, C) = e \end{aligned}$$

1. **Intransitive Sentence.** Consider the sentence “almost all cats sleep”. The many-valued relational meaning of this sentence is

$$\epsilon \circ (\overline{\text{[[almost all]]}} \otimes \mu) \circ (\delta \otimes id) \circ (\overline{\text{[[cats]]}} \otimes \overline{\text{[[sleep]]}})$$

which by remark 7 is equal to

$$\min \left(\star \overline{\text{[[cats]]}} A, \star \overline{\text{[[sleeps]]}} B, \frac{|A \cap F|}{|A|} \right)$$

for $F \subseteq \overline{\text{[[almost all]]}}(A)$ the largest such subset that makes $\frac{|A \cap F|}{|A|} > 0.1$ true. Since all cats fully sleep, that is they sleep with degree 1, the above is equal to

$$\frac{|A \cap F|}{|A|} = \frac{9}{10}$$

So ‘almost all cats sleep’ is true with degree 9/10.

2. **Transitive Sentence with Quantified Object.** Consider the sentence ‘Cats chase around five mice’. By remark 8, the many valued relational meaning of this sentence is

$$\min \left(\star \overline{\text{[[cats]]}} A, \star \overline{\text{[[chase]]}}(A, C), \star \overline{\text{[[mice]]}} D, F \overline{\text{[[around 5]]}} C \cap D \right)$$

for $A \subseteq \overline{\text{[[cats]]}}$, $D \subseteq \overline{\text{[[mice]]}}$, and $(A, C) \subseteq \overline{\text{[[chase]]}}$, and $F \subseteq \overline{\text{[[around 5]]}}(D)$, the largest subset for which $F = C \cap D$ and for which we either have $|F \cap D| = 5$ or 4 or 6. In this case, since all the mice are chased, we have $C \cap D = \{m_1, m_2, \dots, m_{10}\}$. However, F only selects from these between 4 and 6 mice, so for no F it will be the case that $F = C \cap D$. Thus the above becomes equal to

$$\min(e, e, e, \perp) = \perp$$

That is, the many valued meaning of this sentence is false.

3. **Transitive Sentence with Quantified Subject and Object.** Consider the sentence “almost all cats chase almost all mice”. By remark 9, the many valued meaning of this sentence is

$$\min \left(\star \overline{\text{[[cats]]}} A, F \overline{\text{[[almost all]]}} A \cap B, \star \overline{\text{[[chase]]}}(B, C), \star \overline{\text{[[mice]]}} D, F' \overline{\text{[[almost all]]}} C \cap D \right)$$

for $A \subseteq \overline{\text{[[cats]]}}$, $D \subseteq \overline{\text{[[mice]]}}$, $(B, C) \subseteq \overline{\text{[[chase]]}}$, and $F \subseteq \overline{\text{[[almost all]]}}(A)$, $F' \subseteq \overline{\text{[[almost all]]}}(D)$, where F and F' are the largest sets that satisfy the conditions $F = A \cap B$, $\frac{|F \cap A|}{|A|} > 0.1$ and $F' = C \cap D$ and $\frac{|F' \cap D|}{|D|} > 0.1$. In this case the above value becomes equal to

$$\min(e, 0.9, e, e, e) = 0.9$$

Now consider the sentence ‘around 8 cats chase almost all mice’, here, for the best F we have $|F \cap A| = 8$, hence, the value assigned by the fuzzy quantifier ‘around 8’ will be 0.5 and the many valued meaning of the sentence becomes

$$\min(0.5, e, e, e, e) = 0.5$$

Whereas the meaning of ‘around 8 cats chase around 5 mice’ is

$$\min(0.5, e, e, e, \perp) = \perp$$

that is, false.

Example 4. Consider a second model in which the first half of the cats are kittens and they only nap and they only half chase the mice. We model this by assuming that they sleep with degree 0.5 and they chase the mice with degree 0.5. That is

$$\begin{aligned} \star \llbracket \text{sleep} \rrbracket A = \star \llbracket \text{chase} \rrbracket (B, C) &= 0.5, & A, B \subseteq \{c_1, \dots, c_5\}, C \subseteq \{m_1, m_2, \dots, m_{10}\} \\ \star \llbracket \text{sleep} \rrbracket A = \star \llbracket \text{chase} \rrbracket (B, C) &= e, & A, B \subseteq \{c_6, \dots, c_9\}, C \subseteq \{m_1, m_2, \dots, m_{10}\} \end{aligned}$$

In this case, the many valued meanings of our previous sentences become as follows

$$\begin{aligned} \overline{\llbracket \text{almost all cats sleep} \rrbracket} &= \min(e, 0.5, 0.9) = 0.5 \\ \overline{\llbracket \text{cats chase around 5 mice} \rrbracket} &= \min(e, 0.5, \perp) = \perp \\ \overline{\llbracket \text{almost all cats chase almost all mice} \rrbracket} &= \min(e, 0.9, 0.5, e, e) = 0.5 \\ \overline{\llbracket \text{around 8 cats chase almost all mice} \rrbracket} &= \min(0.5, 0.9, 0.5, e, e) = 0.5 \\ \overline{\llbracket \text{around 8 cats chase around 5 mice} \rrbracket} &= \min(0.5, e, 0.5, e, \perp) = \perp \end{aligned}$$

6 Relating Sentence Meanings of MV-Rel to Rel and FVect

How does the many valued meanings of the previous section relate to the meanings computed in [9] and to the fuzzy version of generalised quantifiers developed in [21]?

In other words, if we define the following

Definition 8. *The interpretation of a quantified sentence s is true in $(\mathcal{V}\text{-Rel}, \mathcal{P}(U), \{\star\}, \overline{\llbracket \rrbracket})$ iff $\star \overline{\llbracket s \rrbracket} \star = 1$.*

Definition 9. *The interpretation of a quantified sentence s in $(\mathcal{V}\text{-Rel}, \mathcal{P}(U), \{\star\}, \overline{\llbracket \rrbracket})$ is r -valued iff $\star \overline{\llbracket s \rrbracket} \star = r$.*

can we prove the following?

Proposition 1. *$\star \overline{\llbracket s \rrbracket} \star = 1$ in $(\mathcal{V}\text{-Rel}, \mathcal{P}(U), \{\star\}, \overline{\llbracket \rrbracket})$ iff $\star \overline{\llbracket s \rrbracket} \star$ in $(\text{Rel}, \mathcal{P}(U), \{\star\}, \overline{\llbracket \rrbracket})$.*

More importantly, can prove that

Proposition 2. *$\star \overline{\llbracket s \rrbracket} \star = r$ in $(\mathcal{V}\text{-Rel}, \mathcal{P}(U), \{\star\}, \overline{\llbracket \rrbracket})$ iff $\llbracket s \rrbracket = r$ in Zadeh's fuzzy version of generalised quantifier theory for natural language [21].*

and thus answer yes to the following

Remark 10. Is it possible to give a reasonable definition of semantics in the style of Barwise and Cooper?

On a separate strand, how does our many valued meanings relate to the vector space meanings of natural language? By the Rel to FVect embedding, from the above speculations it follows that:

$$\star \overline{\llbracket s \rrbracket} \star = 1 \quad \text{in} \quad (\mathcal{V}\text{-Rel}, \mathcal{P}(U), \{\star\}, \overline{\llbracket \rrbracket}) \quad \text{iff} \quad \overline{\llbracket s \rrbracket}(\star) \neq 0 \quad \text{in} \quad (\text{FdVect}, V_{\mathcal{P}(U)}, \mathbb{R}, \overline{\llbracket \rrbracket})$$

The question is what happens when we embed V-Rel in FVect? We can refine this question and ask, what happens if we restrict our vector spaces to ones with fixed basis (which is the case in linguistics) and work in the equivalent matrix category? Considering the following diagram,

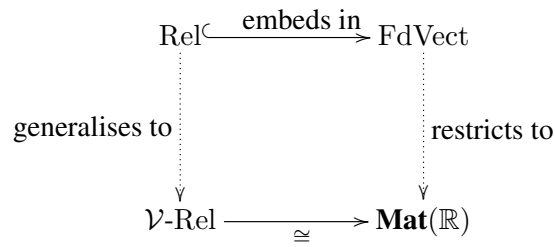

the question can be rephrased as how does one get a fuzzy logic semantics for natural language in $\mathbf{Mat}(\mathbb{R})$ from its vector semantics by working in $\mathcal{V}\text{-Rel}$? The advantages of a yes answer are getting a fuzzy semantics for logical words such as quantifiers and coordination words such as conjunction and disjunction.

7 Conclusions and Future Work

In recent work [9], we showed how one can reason about generalised quantifiers using bialgebras over the category of sets and relations over a fixed powerset object (powerset of a universe of discourse). In that paper, we provided an abstract model and also instantiated it to category of vector spaces and linear maps. Whereas via the *Set-to-Vector Space* and *Relation-to-Linear Map* embedding, the reasoning developed thus far does transfer from sets and relations to vectors and linear maps, the vector space instantiation is hard to reason with. It does not allow for a natural notion of logic in it and further, in order to keep the resulting maps linear, we have had to work with vector spaces over powerset objects, but in a setting where the interpretation of the the union and intersection of sets of basis is not their usual set theoretic operations.

The reason for transferring the relational model of previous work to vector spaces was to allow for quantitative reasoning, This type of reasoning comes necessary when one wants to work with real natural language data, which come in the form of frequencies and statistics. In this current report, we showed how one can make the relational reasoning quantitative by moving instead to the category of sets and many valued relations. We showed that this category is compact closed and defined the required bialgebras over it. We developed within this category, a many valued version of the abstract compact closed categorical semantics of [9] and showed, by way of remarks (that can be made into lemmas and propositions) and examples, how one can compute a many valued semantics for quantified sentences of natural language. It remains to make this work more formal, that is, to relate it formally to vector space models of natural language, e.g. via category of matrices, and also implement it on real data and experiment with it. These constitute work in progress.

8 Acknowledgement

Support by EPSRC for Career Acceleration Fellowship EP/J002607/2 is gratefully acknowledged by both authors.

References

1. Barwise, J., Cooper, R.: Generalized quantifiers and natural language. *Linguistics and Philosophy* 4, 159–219 (1981)
2. Bonchi, F., Sobocinski, P., Zanasi, F.: Interacting bialgebras are Frobenius. In: *Proceedings of FoSSaCS 2014*. vol. 8412, pp. 351–365. Springer (2014)
3. Coecke, B., Sadrzadeh, M., Clark, S.: Mathematical Foundations for Distributed Compositional Model of Meaning. *Lambek Festschrift. Linguistic Analysis* 36, 345–384 (2010)

4. Coecke, B., Grefenstette, E., Sadrzadeh, M.: Lambek vs. lambek: Functorial vector space semantics and string diagrams for lambek calculus. *Annals of Pure and Applied Logic* 164(11), 1079 – 1100 (2013), special issue on Seventh Workshop on Games for Logic and Programming Languages (GaLoP VII)
5. Coecke, B., Paquette, É.O., Pavlovic, D.: Classical and quantum structuralism. In: Gay, S., Mackie, I. (eds.) *Semantical Techniques in Quantum Computation*. pp. 29–69. Cambridge University Press (2009)
6. Grefenstette, E., J., M.: Experimental support for a categorical compositional distributional model of meaning. In: *Proceedings of Conference on Empirical Methods in Natural Language Processing (EMNLP)*. pp. 1394–1404 (2011)
7. Grefenstette, E., Dinu, G., Zhang, Y., Sadrzadeh, M., Baroni, M.: Multi-step regression learning for compositional distributional semantics. In: *10th International Conference on Computational Semantics (IWCS)*. Postdam (2013)
8. Grefenstette, E., Sadrzadeh, M.: Concrete models and empirical evaluations for the categorical compositional distributional model of meaning. *Computational Linguistics* 41, 71–118 (2015)
9. Hedges, J., Sadrzadeh, M.: A generalised quantifier theory of natural language in categorical compositional distributional semantics with bialgebras (2016), <http://arxiv.org/abs/1602.01635>
10. Kartsaklis, D., Sadrzadeh, M., Pulman, S.: A unified sentence space for categorical distributional-compositional semantics: Theory and experiments. In: *Proceedings of 24th International Conference on Computational Linguistics (COLING 2012): Posters*. pp. 549–558. Mumbai, India (2012)
11. Kelly, G., Laplaza, M.: Coherence for compact closed categories. *Journal of Pure and Applied Algebra* 19(0), 193 – 213 (1980), <http://www.sciencedirect.com/science/article/pii/0022404980901012>
12. Kock, A.: Strong functors and monoidal monads. *Archiv der Mathematik* 23, 113–120 (1972)
13. McCurdy, M.: Graphical methods for Tannaka duality of weak bialgebras and weak Hopf algebras. *Theory and applications of categories* 26(9), 233–280 (2012)
14. Milajevs, D., Kartsaklis, D., Sadrzadeh, M., Purver, M.: Evaluating neural word representations in tensor-based compositional settings. In: *Proceedings of the 2014 Conference on Empirical Methods in Natural Language Processing (EMNLP)*. pp. 708–719. Association for Computational Linguistics (2014)
15. Preller, A., Sadrzadeh, M.: Bell states and negative sentences in the distributed model of meaning. In: B. Coecke, P. Panangaden, P.S. (ed.) *Electronic Notes in Theoretical Computer Science, Proceedings of the 6th QPL Workshop on Quantum Physics and Logic*. University of Oxford (2010)
16. Sadrzadeh, M.: Quantifier scope in categorical compositional distributional semantics. In: *Proceedings of the 2016 Workshop on Semantic Spaces at the Intersection of NLP, Physics and Cognitive Science, SLPCS@QPL 2016, Glasgow, Scotland, 11th June 2016*. pp. 49–57 (2016), <http://dx.doi.org/10.4204/EPTCS.221.6>
17. Sadrzadeh M., C.S., Coecke, C.: Forbenius anatomy of word meanings i: subject and object relative pronouns. *Journal of Logic and Computation* 23, 1293–1317 (2013)
18. Sadrzadeh M., C.S., Coecke, C.: Forbenius anatomy of word meanings 2: possessive relative pronouns. *Journal of Logic and Computation* 26, 785–815 (2016)
19. Stephen Clark, B.C., Sadrzadeh, M.: A compositional distributional model of meaning. In: *Proceedings of the Second Symposium on Quantum Interaction (QI)*. pp. 133–140 (2008)
20. Stephen Clark, Bob Coecke, M.S.: The frobenius anatomy of relative pronouns. In: *13th Meeting on Mathematics of Language (MoL)* (2013)
21. Zadeh, L.A.: A computational approach to fuzzy quantifiers in natural languages. *Computers & Mathematics with Applications* 9(1), 149 – 184 (1983), <http://www.sciencedirect.com/science/article/pii/0898122183900135>